

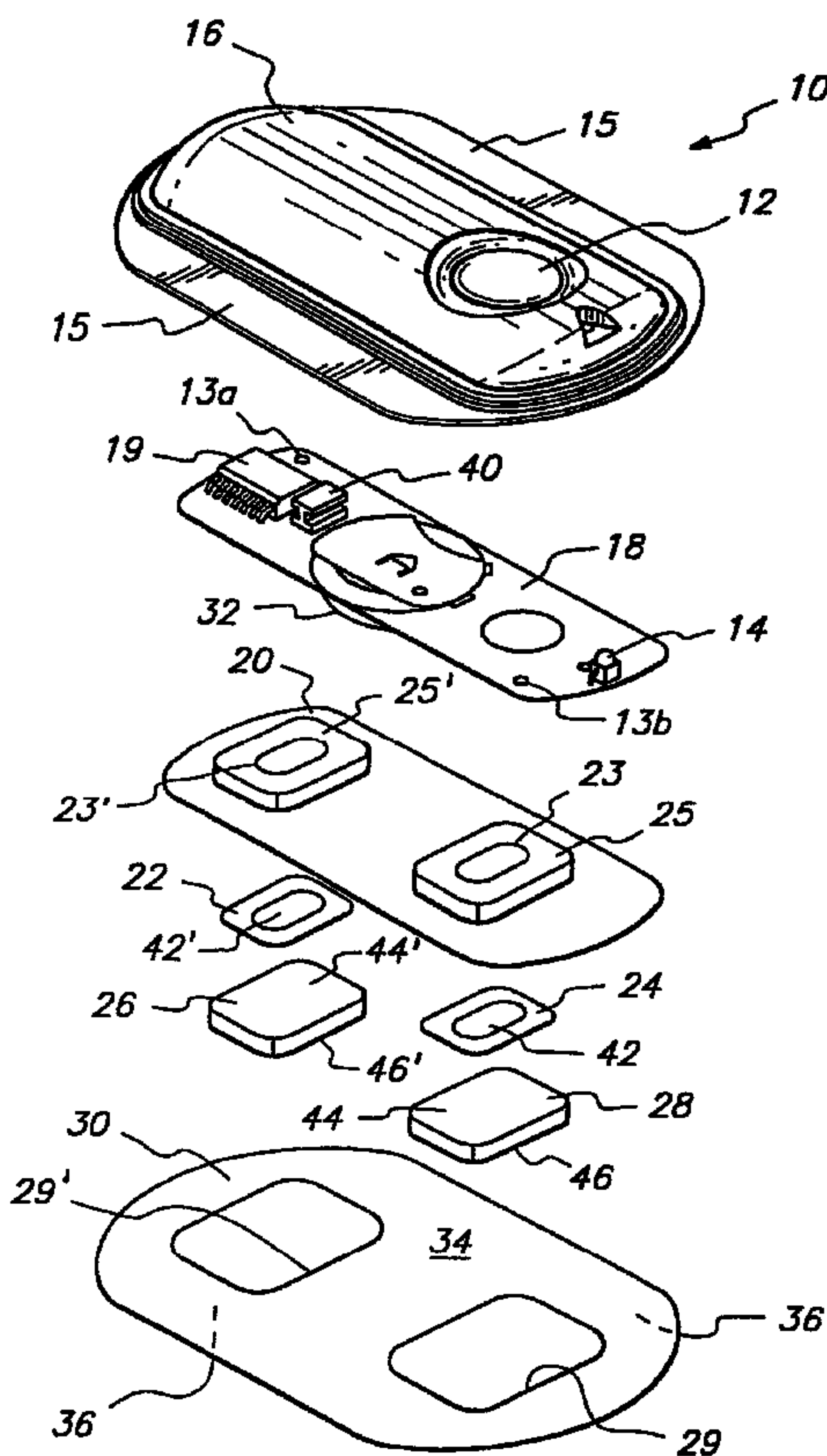

(86) Date de dépôt PCT/PCT Filing Date: 1996/06/07
 (87) Date publication PCT/PCT Publication Date: 1996/12/19
 (45) Date de délivrance/Issue Date: 2006/06/13
 (85) Entrée phase nationale/National Entry: 1997/10/21
 (86) N° demande PCT/PCT Application No.: US 1996/009989
 (87) N° publication PCT/PCT Publication No.: 1996/040364
 (30) Priorité/Priority: 1995/06/07 (US08/483,069)

(51) Cl.Int./Int.Cl. *A61N 1/30* (2006.01),
A61N 1/32 (2006.01)
 (72) Inventeurs/Inventors:
PHIPPS, J. BRADLEY, US;
LATTIN, GARY A., US;
HAAK, RONALD P., US;
THEEUWES, FELIX, US;
GUPTA, SUNEEL, US
 (73) Propriétaire/Owner:
ALZA CORPORATION, US
 (74) Agent: SMART & BIGGAR

(54) Titre : PROCEDE ET APPAREIL D'ADMINISTRATION D'AGENTS PAR ELECTROTRANSPORT
 (54) Title: ELECTROTRANSPORT AGENT DELIVERY METHOD AND APPARATUS



(57) **Abrégé/Abstract:**

An electrotransport agent delivery device (10) for delivering a therapeutic agent through intact skin, and a method of operating same, is provided. The device applies a pulsing electrotransport current wherein current pulses have a magnitude above a critical level (I_c) at which the skin is transformed into a higher electrotransport delivery efficiency (E) state. Most preferably the length of the applied current pulses is at least 5 msec and preferably at least 10 msec.

PCT

WORLD INTELLECTUAL PROPERTY ORGANIZATION
International Bureau

INTERNATIONAL APPLICATION PUBLISHED UNDER THE PATENT COOPERATION TREATY (PCT)

(51) International Patent Classification ⁶ : A61N 1/32	A1	(11) International Publication Number: WO 96/40364 (43) International Publication Date: 19 December 1996 (19.12.96)
<p>(21) International Application Number: PCT/US96/09989</p> <p>(22) International Filing Date: 7 June 1996 (07.06.96)</p> <p>(30) Priority Data: 08/483,069 7 June 1995 (07.06.95) US</p> <p>(71) Applicant (for all designated States except US): ALZA CORPORATION [US/US]; 950 Page Mill Road, P.O. Box 10950, Palo Alto, CA 94303-0802 (US).</p> <p>(72) Inventors; and (75) Inventors/Applicants (for US only): PHIPPS, J., Bradley [US/US]; 5309 Ximines Lane, Plymouth, MN 55442 (US). LATTIN, Gary, A. [US/US]; 6927 145th Avenue, Forest Lake, MN 55025 (US). HAAK, Ronald, P. [US/US]; 2647 Alpine Road, Menlo Park, CA 94025 (US). THEEUWES, Felix [BE/US]; 27350 Altamont Road, Los Altos Hills, CA 94022 (US). GUPTA, Suneel [IN/US]; 4028 Farm Hill Road, No. 5, Redwood City, CA 94061 (US).</p> <p>(74) Agents: MILLER, D., Byron et al.; Alza Corporation, 950 Page Mill Road, P.O. Box 10950, Palo Alto, CA 94303-0802 (US).</p>	<p>(81) Designated States: AL, AM, AT, AU, AZ, BB, BG, BR, BY, CA, CH, CN, CZ, DE, DK, EE, ES, FI, GB, GE, HU, IS, JP, KE, KG, KP, KR, KZ, LK, LR, LS, LT, LU, LV, MD, MG, MK, MN, MW, MX, NO, NZ, PL, PT, RO, RU, SD, SE, SG, SI, SK, TJ, TM, TR, TT, UA, UG, US, UZ, VN, ARIPO patent (KE, LS, MW, SD, SZ, UG), Eurasian patent (AM, AZ, BY, KG, KZ, MD, RU, TJ, TM), European patent (AT, BE, CH, DE, DK, ES, FI, FR, GB, GR, IE, IT, LU, MC, NL, PT, SE), OAPI patent (BF, BJ, CF, CG, CI, CM, GA, GN, ML, MR, NE, SN, TD, TG).</p> <p>Published <i>With international search report. Before the expiration of the time limit for amending the claims and to be republished in the event of the receipt of amendments.</i></p>	

(54) Title: ELECTROTRANSPORT AGENT DELIVERY METHOD AND APPARATUS

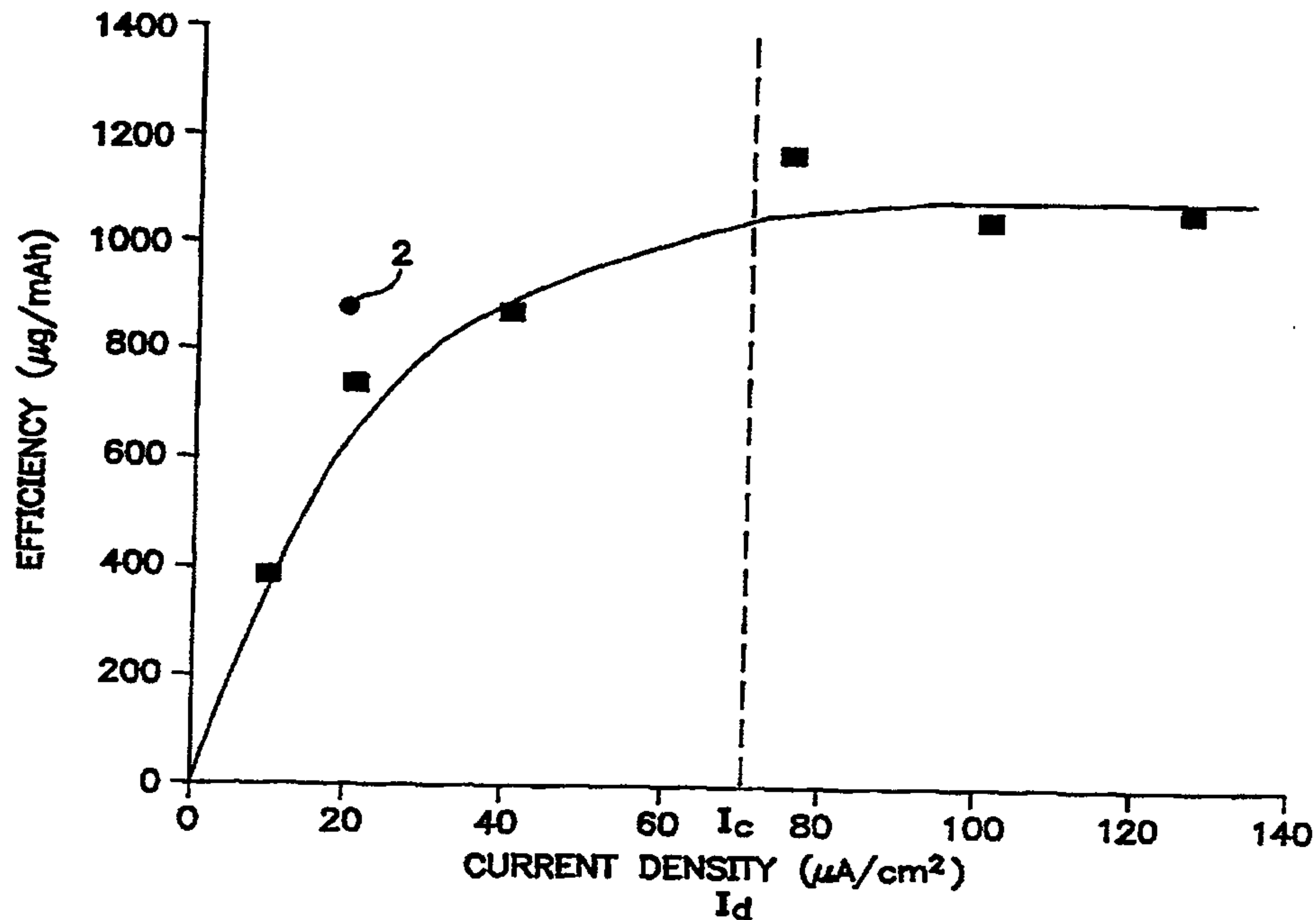

(57) Abstract

An electrotransport agent delivery device (10) for delivering a therapeutic agent through intact skin, and a method of operating same, is provided. The device applies a pulsing electrotransport current wherein current pulses have a magnitude above a critical level (I_c) at which the skin is transformed into a higher electrotransport delivery efficiency (E) state. Most preferably the length of the applied current pulses is at least 5 msec and preferably at least 10 msec.

1 **ELECTROTRANSPORT AGENT DELIVERY METHOD AND APPARATUS**

2

3

TECHNICAL FIELD

4

5

6

7

8

9

10

BACKGROUND OF THE INVENTION

11

12

13

14

15

16

17

18

19

20

21

22

23

24

25

26

27

28

29

30

31

32

The present invention generally concerns a method and apparatus for the electrically assisted delivery of a therapeutic agent (e.g., a drug) through a body surface (e.g., intact skin) at increased efficiency. This invention is particularly applicable to the electrotransport of highly potent therapeutic agents which are to be delivered at small dosage levels.

The present invention concerns in vivo methods and apparatuses for transdermal electrotransport delivery of therapeutic agents, typically drugs. Herein the terms "electrotransport", "iontophoresis" and "iontophoretic" are used to refer to methods and apparatus for transdermal delivery of therapeutic agents, whether charged or uncharged, by means of an applied electromotive force to an agent-containing reservoir. The particular therapeutic agent to be delivered may be completely charged (i.e., 100% ionized), completely uncharged, or partly charged and partly neutral. The therapeutic agent or species may be delivered by electromigration, electroosmosis or a combination of these processes. Electroosmosis has also been referred to as electrohydrokinesis, electro-convection, and electrically-induced osmosis. In general, electroosmosis of a therapeutic species into a tissue results from the migration of solvent, in which the species is contained, as a result of the application of electromotive force to a reservoir containing the therapeutic species.

As used herein, the terms "electrotransport", "iontophoresis" and "iontophoretic" refer to (1) the delivery of charged drugs or agents by electromigration, (2) the delivery of uncharged drugs or agents by the process of electroosmosis, (3) the delivery of species by transport processes which include an electroporation step (See, e.g., Weaver et al. U.S. Patent 5,019,034), (4) the delivery of charged drugs or agents by the combined processes of electromigration and electroosmosis, and/or (5) the delivery of

1 a mixture of charged and uncharged drugs or agents by the combined
2 processes of electromigration and electroosmosis, combinations of the above
3 processes to deliver either or both of charged or uncharged species.

4 Iontophoretic devices for delivering ionized drugs through the skin
5 have been known since the early 1900's. See for example, Deutsch U.S.
6 Patent 410,009. In presently known electrotransport devices, at least two
7 electrodes or electrode assemblies are used. Both electrodes/electrode
8 assemblies are disposed so as to be in intimate electrical contact with some
9 portion of the skin of the body. One electrode, called the active or donor
10 electrode, is the electrode from which the ionic substance, agent,
11 medicament, drug precursor or drug is delivered into the body through the
12 skin by iontophoresis. The other electrode, called the counter or return
13 electrode, serves to close the electrical circuit through the body. In
14 conjunction with the patient's skin contacted by the electrodes, the circuit is
15 completed by connection of the electrodes to a source of electrical energy,
16 e.g., a battery. For example, if the ionic substance to be delivered into the
17 body is positively charged, then the positive electrode (the anode) will be the
18 active electrode and the negative electrode (the cathode) will serve to
19 complete the circuit. If the ionic substance to be delivered is negatively
20 charged, then the cathodic electrode will be the active electrode and the
21 anodic electrode will be the counter electrode.

22 As is discussed above, electrotransport delivery devices can be used
23 to deliver uncharged drugs or agents into the body, e.g, transdermally. This
24 is accomplished by a process called electroosmosis. Electroosmosis is the
25 (e.g., transdermal) flux of a liquid solvent (e.g., the liquid solvent containing
26 the uncharged drug or agent) which is induced by the presence of an electric
27 field imposed across the skin by the donor electrode.

28 Electrotransport electrode assemblies/devices generally include a
29 reservoir or source of the beneficial agent or drug (preferably an ionized or
30 ionizable species or a precursor of such species), which is to be delivered
31 into the body by electrotransport. Examples of such reservoirs or sources

1 include a pouch as described in Jacobsen U.S. Patent 4,250,878, a pre-
2 formed gel body as disclosed in Webster U.S. Patent 4,382,529 and Ariura,
3 et al. U.S. Patent 4,474,570 and a receptacle containing a liquid solution as
4 disclosed in Sanderson, et al. U.S. Patent 4,722,726. Such drug reservoirs
5 are connected to the anode or the cathode of an electrotransport device to
6 provide a fixed or renewable source of one or more desired species or
7 agents. Electrical current is typically applied to the reservoir by means of a
8 current distributing member, which may take the form of a metal plate, a foil
9 layer, a conductive screen, or a polymer film loaded with an electrically
10 conductive filler such as silver or carbon particles. The current distributing
11 member, including any appropriate connectors and associated connective
12 conductors such as leads, and the reservoir comprise an electrode assembly
13 herein.

14 The prior art has recognized that "competitive" ionic species having
15 the same charge (i.e., the same sign) as the drug ions being delivered by
16 electrotransport have a negative impact on electrotransport drug delivery
17 efficiency. The efficiency (E) of electrotransport delivery of a particular
18 species is defined herein as the rate of electrotransport delivery of that
19 species per unit of applied electrotransport current (mg/mA-h). The prior art
20 further recognized that competitive ionic species were inherently produced
21 during operation of these devices. The competitive species produced are
22 dependent upon the type of electrode material which is in contact with the
23 drug solution. For example, if the electrode is composed of an
24 electrochemically inert material (e.g., platinum or stainless steel), the
25 electrochemical charge transfer reaction occurring at the electrode surface
26 tended to be water electrolysis since water is the overwhelmingly preferred
27 liquid solvent used in electrotransport drug solutions. Water electrolysis
28 produces competing hydronium ions at the anode (in the case of cationic
29 electrotransport drug delivery) and competing hydroxyl ions at the cathode
30 (in the case of anionic electrotransport drug delivery). On the other hand, if
31 the electrode is composed of an electrochemically oxidizable or reducible

1 species, then the electrode itself is oxidized or reduced to form a competitive
2 ionic species. For example, Untereker et al U.S. Patent 5,135,477 and
3 Petelenz et al U.S. Patent 4,752,285 recognize that competitive ionic species
4 are electrochemically generated at both the anode and cathode of an
5 electrotransport delivery device. In the case of an electrotransport delivery
6 device having a silver anodic donor electrode, application of current through
7 the silver anode causes the silver to become oxidized ($\text{Ag} \rightarrow \text{Ag}^+ + \text{e}^-$)
8 thereby forming silver cations which compete with the cationic drug for
9 delivery into the skin by electrotransport. The Untereker and Petelenz
10 patents teach that providing a cationic drug in the form of a halide salt
11 causes a chemical reaction which removes the "competing" silver ions from
12 the donor solution (i.e., by reacting the silver ions with the halide counter ion
13 of the drug to form a water insoluble silver halide precipitate; $\text{Ag}^+ + \text{X}^- \rightarrow$
14 AgX), thereby achieving higher drug delivery efficiency. In addition to these
15 patents, Phipps et al PCT/US95/04497 filed on April 7, 1995 teaches the use
16 of supplementary chloride ion sources in the form of high molecular weight
17 chloride resins in the donor reservoir of a transdermal electrotransport
18 delivery device. These resins are highly effective at providing sufficient
19 chloride for preventing silver ion migration, yet because of the high molecular
20 weight of the resin cation, the resin cation is effectively immobile and hence
21 cannot compete with the drug cation for delivery into the body.

22 The prior art has long recognized that the application of electric
23 current through skin causes the electrical resistance of the skin to decrease.
24 See, for example, Haak et al U.S. Patent 5,374,242 (Figure 3). Thus, as the
25 electrical resistance of the skin drops, lower voltages are needed to drive a
26 particular level of electrotransport current through the skin. This same
27 phenomenon is observed in a technique referred to as "electroporation" of
28 the skin. See Weaver et al U.S. Patent 5,019,034. Electroporation involves
29 the application of short, high voltage electrical pulses to produce what is
30 characterized as a transient (e.g., decreasing to normal levels in 10 to 120
31 sec. for excised frog skin) increase in tissue permeability. Electroporation is

1 also characterized by the creation of pores in lipid membranes due to
2 reversible electrical breakdown. Electroporation does not, itself, deliver any
3 drug but merely prepares the tissue thereby treated for delivery of drug by
4 any of a number of techniques, one of which is iontophoresis.

5 6 DISCLOSURE OF THE INVENTION

7 The present invention arises from the discovery that, under specified
8 conditions of applied electrotransport current density (generally expressed in
9 units of microamperes/cm² herein) and application time, the electrotransport
10 transdermal drug delivery efficiency is enhanced. Electrotransport drug
11 delivery efficiency, E , is defined as the rate of transdermal electrotransport
12 delivery (mg/h) per unit of applied electrotransport current (mA), and
13 expressed in units of milligrams of agent (e.g., drug) delivered per milliamp-
14 hour of applied electric current (mg/mAh). Electrotransport delivery
15 efficiency, in some aspects of its meaning, is analogous to transport number.
16 Transport number is a unitless quantity, less than one, indicating the
17 fractional charge carried by a particular ionic species, e.g., a drug or agent,
18 during electrotransport delivery. Electrotransport delivery efficiency, as
19 defined herein, is more broadly applicable to include the transport of
20 uncharged species and is more reflective of the scope of the invention.

21 The enhancement of the skin's electrotransport efficiency has been
22 found to be non-transitory, i.e., to last for at least several minutes to several
23 hours or longer after application of this invention. This invention induces
24 (e.g., through a pre-treatment or pre-application step in which species are
25 delivered) a high efficiency drug-transmissive state in the skin to which it is
26 applied. The induced, high efficiency state continues and can be utilized to
27 deliver drug or other therapeutic agent transdermally via electrotransport with
28 increased efficiency. In usual circumstances, this will permit delivery of drug
29 with more precise control and at a lower current. This phenomenon has only
30 been found in the transdermal delivery of drug or agent through intact living

1 skin or tissue, (i.e., in vivo) and is not exhibited in dead skin (i.e., excised
2 skin through which species are electrotransported in vitro).

3 Generally speaking, this invention involves delivery of a charged
4 species at or above a pre-determined threshold current density I_c for at least
5 a predetermined period of time t_c (e.g., for a predetermined pulse width)
6 through the site of drug delivery, e.g., intact skin. In this manner, the treated
7 skin exhibits a statistically significant, non-transitory increase in drug delivery
8 efficiency relative to skin which has not been so treated. Generally
9 speaking, utilization of this invention will significantly increase the drug/agent
10 delivery efficiency and reduce or eliminate efficiency variability of the skin
11 segment which is so treated. Since electrotransport delivery efficiency
12 remains elevated or less variable after utilization of this invention (relative to
13 untreated skin), utilization of this invention permits the delivery of drug or
14 agent through intact skin by electrotransport with increased control and
15 efficiency.

16 Briefly, in one aspect, the present invention is a method of
17 electrotransport drug or agent delivery through a body surface involving the
18 steps of:

19 delivering ionic species by electrotransport at a sufficient
20 current density and over a sufficient period which will change or
21 convert the transport efficiency of the body surface through which the
22 ionic species is delivered to a non-transitory state of higher species
23 delivery efficiency; and thereafter

24 delivering drug or agent through the body surface while in its
25 high efficiency state.

26
27 In a preferred practice, current density and species delivery time are
28 selected to maintain the higher efficiency species delivery state of the body
29 surface. This invention also includes the preferred practice of intentionally
30 renewing the highly efficient species delivery state so as to optimize drug
31 delivery efficiency if drug or agent delivery conditions are used which do not

1 periodically renew it. In another preferred practice, the present invention is
2 utilized to deliver drug or agent transdermally, i.e., through intact skin. In yet
3 a further preferred practice, the present invention is used to deliver drug or
4 agent through intact, live, human skin.

5 In the practice of this invention, the precise current density and
6 treatment time period needed to convert untreated skin to a highly
7 transmissive state have been found to be fairly specific to the drug or
8 therapeutic agent to be delivered. However, for the electrotransport delivery
9 of analgesics, which have been the primary focus of this invention, a
10 treatment of the body site through which drug is to be delivered for a time
11 period of at least 5 msec, and preferably at least 10 msec, at a current
12 density of at least about $40 \mu\text{A}/\text{cm}^2$, preferably at least about $50 \mu\text{A}/\text{cm}^2$ and
13 most preferably at least about $70 \mu\text{A}/\text{cm}^2$ appears to convert the body site so
14 treated to a highly drug transmissive state as defined in this invention. This
15 invention arises because of the discovery that electrotransport delivery
16 efficiency is highly dependent (i.e., it is non-constant) at current densities in
17 the range of about 0 to about $30 \mu\text{A}/\text{cm}^2$, is moderately dependent upon
18 current density in the range of about 40 to about $70 \mu\text{A}/\text{cm}^2$ and is relatively
19 independent of current density at current densities in excess of about 70
20 $\mu\text{A}/\text{cm}^2$. This unexpected change in efficiency (in theory, efficiency is not
21 predicted to change with increasing current density) permits transdermal
22 electrotransport delivery of drug with significantly enhanced efficiency.

23 A second unexpected result is achieved in the practice of the present
24 invention, i.e., the change of the skin to the higher efficiency transmissive
25 state is non-transitory with the skin remaining in the higher, and more stable,
26 efficiency state for minutes to hours after the initial transformation, even in
27 cases where the subsequently applied electrotransport current density is
28 lowered to a level below I_c or turned off, completely. In other words, when
29 the skin site has been converted to a highly efficient agent transmissive state
30 by applying a pulsing electric current, the current pulses having a sufficient
31 magnitude to provide a current density at or above the critical current density

1 I_c , and preferably over pulse widths of at least 5 msec reduction in applied
2 electrotransport current (and therefore current density) does not cause the
3 skin to immediately return to its initial, lower efficiency state. This
4 observation respecting in vivo drug delivery is critically important to
5 electrotransport system design.

6 The term "non-transitory" as used herein, when referring to the high
7 efficiency electrotransport agent delivery state, means of sufficient length to
8 permit drug to be delivered to achieve a therapeutic effect. Thus, for
9 example, a relatively inexpensive ionic species may be used to trigger
10 conversion of, e.g., a skin site, to a highly efficient and more stable ionic
11 species delivery state, and thereafter relatively more expensive drug or agent
12 may be delivered at greater efficiency and stability by electrotransport.
13 Where the drug or agent is inexpensive, it may be used to convert the body
14 delivery site to the highly efficient and more stable state, and thereafter may
15 be delivered with greater efficiency, i.e., at lower current density and at
16 greater stability.

17 The term "high/higher efficiency state" as used herein means
18 conversion of any particular body or skin site to a state in which drug or
19 agent delivery is at least 10% (preferably 20%) more efficient than the same
20 skin site prior to conversion in accordance with this invention. Generally, the
21 parameter which will be most reflective of this efficiency increase is the
22 electrotransport delivery efficiency measured in milligrams of drug delivered
23 per milliamp-hour of applied electrotransport current.

24 The term "more stable efficiency" as used herein means conversion of
25 a body surface site from a state of more variable electrotransport agent
26 delivery efficiency to one of less variability by exposure of the body site to a
27 current density above the critical current density I_c for a time period longer
28 than the critical time, t_c . Critical current density for purposes of increased
29 stability, has been found to be as low as about 40 $\mu\text{A}/\text{cm}^2$.

30 In a preferred practice of this invention, it is desirable to be able to
31 change, precisely, drug dosage after the body site has been converted to a

1 highly efficient drug or agent delivery state. In accordance with this
2 invention, total drug or agent delivered (i.e., dosage) may be adjusted while
3 maintaining the required current density to retain the most efficient and
4 stable state, i.e., independent of average current applied by the alternatives
5 of: (a) in a pulsed output electrotransport system, adjustment of device duty
6 cycle while maintaining average current density above the critical current
7 density; (b) in an electrotransport device employing a pulsed output,
8 maintaining constant peak current and pulse width while adjusting pulse
9 frequency to adjust total drug or agent delivered, or (c) the intentional
10 inclusion in and delivery from an "in line" (i.e., to deliver drug) component
11 or subassembly of an electrotransport device of competitive co-ions not
12 having a therapeutic effect converts the system to a stable drug flux at a
13 current density above the critical current density. Delivery of competitive co-
14 ions, for a given current, in addition to the drug or agent ions, provides
15 adequate current density but permits controlled modification of the quantity of
16 therapeutic agent delivered. Delivery of competitive co-ions from, e.g., the
17 drug reservoir, also reduces potentially expensive and potent total drug or
18 agent delivered.

19 Another way to use an inexpensive ionic species to trigger the skin
20 conversion is to utilize a reverse polarity system. One example of such a
21 system would first drive the anionic drug counter ion from the donor reservoir
22 and the cationic substance from the counter reservoir for the time required to
23 convert the skin to a high efficiency state and then reverses polarity, thereby
24 moving the drug cation into the skin.

25 In one practice of this invention, the highly potent analgesic drug,
26 fentanyl, is transdermally delivered via electrotransport at very low current
27 density under conditions at which fentanyl delivery tends to be unstable, i.e.,
28 to exhibit unacceptable drug delivery efficiency variability. Addition of a
29 chloride salt, e.g., sodium chloride, to the electrode assembly drug reservoir
30 provides sufficient co-deliverable, competitive ion (i.e. Na^+) to stabilize
31 fentanyl delivery. In this manner, fentanyl efficiency variability also is

52044-3

10

reduced or eliminated.

According to an aspect of the invention, there is provided an electrotransport device for in vivo delivery of a charged agent through a body surface at a higher
5 electrotransport agent delivery efficiency defined by the agent delivery rate per unit of applied current; the device having a donor reservoir containing the charged agent and having a delivery area, and having a source of electrical power and a current controller, the device being
10 characterized by: the current controller provides an applied pulsing current having a periodic current waveform, a pulsing frequency, and a duty cycle, the pulsing current applied to the reservoir and to the body surface, wherein an applied current density is defined by the applied pulsing
15 current divided by the delivery area, and wherein the body surface exhibits a higher electrotransport agent delivery efficiency when the applied current density is greater than or equal to a critical current density level and the applied pulsing current is applied for greater than or equal to a
20 critical time period.

According to another aspect of the invention, there is provided a use of an electrotransport delivery device having a donor reservoir containing a charged agent and having a delivery area, and having a source of
25 electrical power and a current controller, that is for providing an applied pulsing current having a periodic current waveform, a pulsing frequency, and a duty cycle, to the reservoir and to the body surface for in vivo delivery of a charged agent from the electrotransport delivery device
30 through a body surface at higher electrotransport agent delivery efficiency defined by the agent delivery rate per unit of applied current, wherein

52044-3

10a

an applied current density is defined by the applied pulsing current divided by the delivery area, and wherein the body surface exhibits a higher electrotransport agent delivery efficiency when the applied current density is greater than or equal to a critical current density level and the applied pulsing current is applied for greater than or equal to a critical time period.

These and other aspects of this invention will be discussed below.

10 **BRIEF DESCRIPTION OF THE DRAWINGS**

A better understanding of the present invention, as well as other objects and advantages thereof, will become apparent upon consideration of the following modes for carrying out the invention especially when taken with the accompanying drawings, wherein:

FIG. 1 is a graph of transdermal electrotransport drug delivery efficiency (E) versus applied electrotransport current density (I_a) for in vivo delivery of fentanyl;

FIG. 2 is a graph of electrotransport current versus time, showing three pulsed current waveforms having differing duty cycles;

FIG. 3 is an exploded perspective view of a transdermal electrotransport drug delivery device which can be used in accordance with the method of the present invention;

FIG. 4 is a graph of electrotransport current versus time, showing two pulsed current waveforms having the same peak current and pulse width but different pulsing frequencies;

52044-3

10b

FIG. 5 is a graph of mean serum fentanyl concentration versus time, showing how initial electrotransport administered doses increase subsequent fentanyl delivery through a 24 hour period;

5 FIG. 6 is a graph of average serum fentanyl concentration, as a function of time, for applied electrotransport current densities of 10, 20 and 40 $\mu\text{A}/\text{cm}^2$;

10 FIG. 7 is a graph of serum fentanyl concentration versus time for delivery of fentanyl at pulsing frequencies of 1, 10, and 625 Hz; and

FIG. 8 is a graph of serum goserelin concentration versus time, for applied electrotransport current densities of 50 and 100 $\mu\text{A}/\text{cm}^2$.

MODES FOR CARRYING OUT THE INVENTION

1
2 The present invention is based upon the discovery that the efficiency
3 (E) of transdermal electrotransport agent (e.g., drug) delivery is, at least at
4 lower applied electrotransport current densities, dependent on the applied
5 electrotransport current density (I_d). This phenomenon is illustrated
6 graphically in FIG. 1. Specifically, we have discovered that when
7 electrotransport current densities at or above a critical current density level,
8 I_c , are applied to the skin of living animals for a sufficient period of time, at
9 least as long as a critical period of time t_c on the order of several
10 milliseconds, the electrotransport drug delivery efficiency (E) increases and
11 becomes independent of the level of applied electrotransport current density.
12 It is important to note that the variable electrotransport delivery efficiency
13 effect is a limited exception to the widely reported principle that transdermal
14 electrotransport drug flux is dependent (i.e., linearly dependent) upon the
15 level of applied electrotransport current. Our discovery is that this principle is
16 only true at current densities at or above a critical current density level I_c .
17 Thus, we have discovered that, at applied current densities below the critical
18 current density level I_c , the rate of electrotransport drug delivery per unit of
19 applied electrotransport current is not constant as has been previously
20 assumed. Not only is the electrotransport drug delivery efficiency (E)
21 variable at lower current densities, it is also lower than at current densities
22 above the critical level I_c . Thus, at applied current densities below I_c , the
23 electrotransport delivery is less efficient in that more electrotransport current
24 must be applied to deliver a predetermined amount of drug. A still further
25 aspect of our discovery is that the interpatient variability in transdermal
26 electrotransport efficiency is lower at applied current densities above the
27 critical level I_c and higher at applied current density levels below the critical
28 level I_c .

29 In general, the critical current density level I_c for human skin is in the
30 range of about 40 to 100 $\mu\text{A}/\text{cm}^2$, although the critical level I_c will vary
31 somewhat depending upon (i) the particular drug being delivered, (ii) the

1 particular patient being treated, and (iii) the particular skin location of the
2 patient wearing the electrotransport device. Typically, a current density at or
3 above the critical level I_c need only be applied for several milliseconds to
4 several seconds before the skin enters the high efficiency drug transfer state.
5 However, applied current densities below the critical level I_c are unable to
6 transform the skin into the high efficiency transfer state, even when these
7 low level current densities are applied for extended periods of time (e.g., up
8 to several hours application). This transformation of the skin to a higher
9 efficiency delivery state occurs only in living animals and does not occur with
10 excised skin taken from living or dead animals, i.e., the skin transformation
11 has not been found to occur when in vitro flux studies were run.

12 Once the skin has been transformed into the high efficiency transfer
13 state, it tends to remain in that state for an extended period of time (e.g., up
14 to 24 hours) even if no further electrotransport current is thereafter applied to
15 the skin or if only low level current densities (i.e., current densities less than
16 the critical level I_c) are thereafter applied to the skin. This result is illustrated
17 in FIG. 5 and is discussed below. The "transformed" skin is in general only
18 those skin sites which are in contact with the donor and counter
19 electrodes/reservoirs of the electrotransport delivery device and through
20 which skin sites the applied current has been passed. Thus, if a skin site on
21 the upper arm of a patient has been transformed by application of
22 electrotransport current densities at or above the critical level I_c , the skin on
23 the lower (same) arm, the legs, torso or other arm of the patient does not
24 become transformed. The skin transformation of this invention is a localized
25 phenomenon which is limited to those portions of the skin to which the donor
26 and counter electrodes/reservoirs are attached. Since the skin at the
27 counter electrode site also is converted to the higher efficiency delivery state,
28 methods and devices for delivering agents from the "donor" and "counter"
29 electrodes or both electrodes (e.g., by alternating current polarity) are within
30 the scope of this invention.

1 Our discovery is particularly critical in those transdermal
2 electrotransport drug delivery regimens wherein the drug is delivered at two
3 (or more) different dosing levels, one dosing level being administered at a
4 current density below the critical level I_c and another dosing level being
5 administered at a current density above the critical level. For example,
6 many drugs are adapted to be administered at a low dose baseline rate for
7 extended periods, the baseline rate being interrupted periodically by periods
8 of higher dosing. Examples of drugs which are administered in this fashion
9 include (1) analgesics, such as fentanyl and sufentanil, which are
10 administered at a low baseline level to treat (e.g., chronic) pain and which
11 are periodically delivered at higher doses to treat more severe episodes of
12 pain; (2) anti-emetics, such as the 5HT₃ receptor antagonists ondansetron
13 and granisetron, which are administered continuously at low levels (e.g.,
14 during weeks over which a patient is undergoing chemotherapy) and which
15 are periodically administered at higher dosing levels (i.e., during the actual
16 chemotherapeutic administration); (3) anti-epileptics, such as phenytoin,
17 which are delivered continuously at low baseline levels and periodically at
18 higher levels when the patient is undergoing an epileptic seizure; and (4)
19 anti-diabetic drugs, such as insulins, which can be delivered continuously at
20 low baseline levels and periodically (e.g., around meal times) at higher
21 levels. The problem encountered with this type of transdermal
22 electrotransport drug administration is that after the drug is administered at
23 the higher dosing rate (with the applied current density above the critical
24 level, I_c), when the applied electrotransport current is readjusted to apply the
25 original lower baseline level, the transdermal electrotransport drug flux does
26 not return to the same baseline level. The drug flux instead falls to a level
27 somewhere between the original baseline rate and the high dosing rate,
28 because the skin has been transformed into a higher efficiency drug delivery
29 state. For example, if the efficiency is enhanced by a factor of two, after
30 the skin has experienced a current density above the critical current density,
31 and then the current is lowered to the original baseline current, the drug

1 delivery rate would be twice that experienced before the transformation. The
2 higher baseline rate could result in a drug overdose if the electrotransport
3 system does not compensate for this shift in efficiency. To eliminate this
4 problem, the electrotransport system should reduce the current applied (e.g.,
5 by approximately a factor of two) after the skin has experienced a current
6 density greater than I_c . With reference to FIG. 1, data point 2 is a likely
7 efficiency that would be experienced at the drug delivery site were current
8 (and therefore current density) reduced after exposure of the body site to a
9 current density at or above I_c for at least a period of time t_c . At data point
10 "2", the electrotransport agent delivery efficiency is higher than the agent
11 delivery efficiency which was experienced initially (i.e., before exposure to a
12 current density above I_c) at the current density of $20 \mu\text{A}/\text{cm}^2$.

13 A more elegant approach to this problem is to apply a pulsed
14 electrotransport current to the skin, the pulsing current having a magnitude
15 above the critical level I_c , and to modify the duty cycle of the pulses to
16 increase or decrease the amount of drug delivered. The term "duty cycle"
17 as used herein is the ratio of "on" time interval to the period of time of one
18 cycle (i.e., the ratio of the pulse-duration time to the pulse-period) and is
19 usually expressed as a percent. For example, if a device is "on" for 500 ms
20 of a 1 sec cycle, then the device is operating in a 50% duty cycle. In this
21 practice of the invention, the magnitude of the current pulses is selected in
22 view of the known area of the surface from which drug is delivered, thereby
23 defining a fixed and known current density (i.e., the ratio of current to the
24 area from which current flows). Thus, if it is decided, based upon application
25 of the above principles, that a specific maximum current for a given anode
26 surface area e.g., I_{max} , will provide the enhanced efficiency drug delivery
27 discussed above, then by increasing or decreasing the duty cycle, the
28 amount of drug delivered at the high efficiency state can be increased or
29 decreased without causing the applied current density to change. In
30 choosing the parameters of drug delivery if using this approach, the
31 magnitude of the current pulses is selected so that the resulting current

1 density transforms the skin into the high efficiency state and the duty cycle
2 of the current pulses is altered to adjust the drug delivery rate (i.e., a low
3 dose of drug is administered by a high density (i.e., greater than or equal to
4 I_c) pulsing current having a low duty cycle and a high dose of drug is
5 administered by the same magnitude current density but being pulsed at a
6 longer pulse width corresponding to a higher duty cycle.

7 This aspect of the invention is more specifically illustrated in Fig. 2
8 where waveforms for three different pulsing electrotransport currents of the
9 same frequency are shown. In FIG. 2 time is illustrated on the horizontal
10 axis, while current amplitude is illustrated on the vertical axis. The three
11 current waveforms shown in FIG. 2 all have the same magnitude, and hence
12 the same maximum applied current density I_{max} for an electrotransport
13 delivery device of any one size. This particular current density I_{max} is greater
14 than the critical current density level I_c . The three current waveforms have
15 differing duty cycles, which is the percentage of time during which the
16 current is applied. The three waveforms have duty cycles of 75% (top
17 waveform), 50% (middle waveform) and 25% (bottom waveform). Thus, the
18 25% duty cycle waveform delivers drug transdermally by electrotransport at
19 about one-half the dosing level of the 50% duty cycle waveform and about
20 one-third the dosing level of the 75% duty cycle waveform. All three
21 waveforms administer drug transdermally by electrotransport through skin
22 which is transformed into the high efficiency transfer state by reason of I_{max}
23 being greater than I_c .

24 In a further practice of this invention, the pulsing frequency of a
25 pulsed current waveform is adjusted to control the overall quantity of drug
26 delivered while holding the pulse width constant and maintaining the
27 magnitude of current pulses at or above I_c . In this manner, current density is
28 maintained at or above the level which transforms the skin into the high
29 efficiency state. Exemplary of this, a device employing a pulsed current
30 waveform having current pulses with a magnitude of 0.2 mA, a pulse width
31 of 10 msec, and a frequency of 10 Hz will deliver roughly half as much drug

1 as the same device run at a frequency of 20 Hz. Given a constant drug
2 delivery area, e.g., of an electrode assembly, the applied current densities of
3 these two devices is the same and is above the high efficiency critical level I_c
4 so that both devices deliver drug transdermally by electrotransport with
5 higher efficiency and lower variability compared to devices which apply
6 electrotransport current at current densities below the critical level I_c . From
7 these two examples of the invention, one skilled in this art will appreciate
8 that a combination of frequency and duty cycle may be used to alter the rate
9 of drug delivery while maintaining the maximum applied current density, I_{max} ,
10 above I_c . FIG. 4 shows the waveforms for a device operated to have a
11 constant 9 msec pulse width, the frequency for a device operated according
12 to the lower waveform being one-half that of a device operated according to
13 the upper waveform (i.e., 50 Hz versus 100 Hz).

14 As is noted above, agent delivery efficiency is increased by exposure
15 of the site to a current density at or above I_c and for a time period equal to
16 or greater than a critical time, t_c . Generally speaking, for a pulsing
17 electrotransport device, the pulse width must equal or exceed t_c . Thus, t_c , in
18 a practice of this invention using pulsed current electrotransport devices and
19 for delivery of fentanyl, falls between about 0.5 msec and 30 msec. It is
20 believed that the minimum pulse width to cause transformation to the higher
21 efficiency state is about 10 msec for fentanyl.

22 Table 1 shows data which support the above observation. Table 1
23 shows drug delivery efficiency data for a device programmed to run at
24 frequencies of 1 Hz, 10 Hz and 625 Hz. A 31% duty cycle was employed.
25
26

TABLE 1

Frequency Hz	Pulse Width	Rate of Fentanyl Delivery µg/hr.	
		Without Bolus Treatment	After Bolus Treatment*
625	0.5 msec	7	34
10	31 msec	52**	52**
1	310 msec	48**	48**

* "Bolus Treatment" means a direct current bolus delivery of fentanyl for a period of 30 minutes at a current density of 0.1mA/cm².

** The numbers in these two columns are the same because even at a pulse width as short as 31 msec, the skin site had already transformed to its highly efficient state.

Table 1 also indicates that fentanyl delivery is significantly lower at a high pulsing frequency of 625 Hz compared to the lower pulsing frequencies of 1 and 10 Hz. This phenomenon is called capacitive loss, which loss becomes greater as pulsing frequency is increased at a given duty cycle. Capacitive loss results because a portion of each pulse is consumed by the process of charging the skin without delivering drug. The shorter the pulse width (and hence the higher the pulsing frequency), the greater (relatively speaking) the capacitive loss for each pulse. Table 1 also shows that until a critical pulse width is achieved, regardless of frequency, no transformation of the body site agent delivery efficiency occurs.

Pulsed current electrotransport devices are well known in the art. Such devices are described in numerous technical articles and the patent literature including Bagniefski et al. "A Comparison of Pulsed and Continuous Current Iontophoresis", Journal of Controlled Release, 113-122, (1090); McNichols et al., U.S. patent 5,047,007; Sibalís U.S. Patent 5,135,478; R. Burnette et al. "Influence of Constant Current Iontophoresis on the Impedance and Passive Na⁺ Permeability of Excised Nude Mouse Skin",

1 77 J.Pharmaceutical Sciences 492 (1988); Pikal et al, "Study of the
2 Mechanisms of Flux Enhancement Through Hairless Mouse Skin by Pulsed
3 DC Iontophoresis," 8 Pharmaceutical Research 365 (1991).

4 Another method of transdermally delivering a therapeutic agent (e.g.,
5 a drug) by electrotransport at an applied current density at or above the
6 critical level I_c but at a lower dosing/delivery rate (i.e., a rate which requires a
7 current lower than that achieved when applying a current sufficient to
8 achieve a current density of at least I_c) involves the intentional introduction of
9 competitive ions having the same (i.e., same polarity) charge as the
10 therapeutic agent ions. This approach, under the specific conditions
11 described, permits drug dosage control as well as providing enhanced
12 stability and enhanced efficiency of electrotransport of therapeutic agent.
13 This approach is generally discouraged in the patent literature because it
14 otherwise tends to reduce drug delivery efficiency. This aspect of this
15 invention is particularly applicable to electrotransport delivery of those drugs
16 or therapeutic agents which are therapeutically effective when (i) delivered at
17 low transdermal fluxes and/or (ii) when present in low concentrations in the
18 blood. Generally speaking, this aspect of the present invention is particularly
19 applicable to the electrotransport delivery of highly potent drugs or other
20 therapeutic agents.

21 The competitive ionic species can be loaded into the donor reservoir
22 (e.g., a biocompatible salt is added to the donor reservoir) before
23 electrotransport agent delivery and/or can be generated in situ during the
24 operation of the electrotransport device. Generation of competitive ionic
25 species in situ may be accomplished using a secondary electrode and
26 appropriate electrical control circuitry as described in Phipps et al US Patent
27 5,443,442 for example.

28 The amount of the competitive species intentionally added to the
29 donor reservoir will be specific to the drug or agents to be delivered and the
30 relative electrophoretic mobilities of the drug ions and the competing ionic
31 species. Generally, the competitive species will be ionic and should have

1 delivery characteristics similar to those of the drug being delivered. The
2 quantity of co-delivered species to be added is selected so that the total
3 current density is raised above the critical current density, I_c , where the ionic
4 species efficiency is normalized or stabilized so that variation of delivery
5 efficiency is no longer experienced.

6 The teachings in Theeuwes et al. U.S. Patent 5,080,646 may be
7 utilized in determining the proper amount of competitive co-ion species to be
8 added to the donor reservoir of an electrotransport delivery device. The
9 patent discusses the processes involved in the transport of species through
10 a biological surface such as skin, mucosa, or tissue. The Theeuwes et al
11 patent provides a mathematical analysis which permits one skilled in this art,
12 when unacceptable random variability of electrically-assisted drug flux is
13 experienced, to select a suitable quantity and species of competitive co-ion
14 to be delivered along with the drug or agent.

15 The transdermal electrotransport drug delivery efficiency may be
16 increased, when using a pulsing electrotransport current, by maintaining the
17 pulse width equal to or greater than t_c . In general, this requires the pulsing
18 frequency to be maintained below about 100 Hz, and preferably less than
19 about 10 Hz. The term "pulsing electrotransport current" as used herein
20 means a current which varies in a periodic fashion. A pulsing
21 electrotransport current which transforms the skin to the high efficiency
22 transfer state is one where at least a portion of the periodic current
23 waveform provides a current density below I_c , and another portion which has
24 a sufficient magnitude and pulse width to effect transformation of the skin to
25 the higher efficiency drug delivery state. This then provides the second of
26 the two necessary and sufficient parameters (after current density I_c) which
27 must be satisfied to apply this invention. As was noted above, pulsing
28 frequencies in the relatively low ranges discussed here combined with
29 sufficient duty cycle, provide the pulse width needed for in vivo skin drug
30 delivery efficiency to increase. For example, a frequency of about 10 Hz
31 (i.e., a period of about 100 msec) and a duty cycle of 31% was found to

1 provide a pulse width of 31 msec which was long enough to induce a skin
2 efficiency increase to deliver fentanyl at a current density of 0.1 mA/cm².

3 Reference is now made to FIG. 3 which depicts an exemplary
4 electrotransport device which can be used in accordance with the present
5 invention. FIG. 3 shows a perspective exploded view of an electrotransport
6 device 10 having an activation switch in the form of a push button switch 12
7 and a display in the form of a light emitting diode (LED) 14. Device 10
8 comprises an upper housing 16, a circuit board assembly 18, a lower
9 housing 20, anode electrode 22, cathode electrode 24, anode reservoir 26,
10 cathode reservoir 28 and skin-compatible adhesive 30. Upper housing 16
11 has lateral wings 15 which assist in holding device 10 on a patient's skin.
12 Upper housing 16 is preferably composed of an injection moldable elastomer
13 (e.g., ethylene vinyl acetate). Printed circuit board assembly 18 comprises
14 an integrated circuit 19 coupled to discrete electrical components 40 and
15 battery 32. Circuit board assembly 18 is attached to housing 16 by posts
16 (not shown in FIG. 3) passing through openings 13a and 13b, the ends of
17 the posts being heated/melted in order to heat stake the circuit board
18 assembly 18 to the housing 16. Lower housing 20 is attached to the upper
19 housing 16 by means of adhesive 30, the upper surface 34 of adhesive 30
20 being adhered to both lower housing 20 and upper housing 16 including the
21 bottom surfaces of wings 15.

22 Shown (partially) on the underside of circuit board assembly 18 is a
23 battery 32, which is preferably a button cell battery and most preferably a
24 lithium cell. Other types of batteries, such as sizes AAA and AAAA, may
25 also be employed to power device 10.

26 The circuit outputs (not shown in FIG. 3) of the circuit board assembly
27 18 make electrical contact with the electrodes 24 and 22 through openings
28 23,23' in the depressions 25,25' formed in lower housing, by means of
29 electrically conductive adhesive strips 42,42'. Electrodes 22 and 24, in turn,
30 are in direct mechanical and electrical contact with the top sides 44',44 of
31 drug reservoirs 26 and 28. The bottom sides 46',46 of drug reservoirs 26,28

52044-3

21

contact the patient's skin through the openings 29',29 in adhesive 30. Upon depression of push button switch 12, the electronic circuitry on circuit board assembly 18 delivers a predetermined DC current to the electrodes/reservoirs 22,26 and 24,28 for a delivery interval of predetermined length, e.g., about 10 minutes. Preferably, the device transmits to the user a visual and/or audible confirmation of the onset of the drug delivery, or bolus, interval by means of LED 14 becoming lit and/or an audible sound signal from, e.g., a "beeper". Drug (e.g., an analgesic drug such as fentanyl) is then delivered through the patient's skin, e.g., on the arm, for the predetermined (e.g., 10 minute) delivery interval. In practice, a user receives feedback as to the onset of the drug delivery interval by visual (LED 14 becomes lit) and/or audible signals (a beep from the "beeper"). A preferred device is described in commonly owned, patent entitled "Display for an Electrotransport Device", U.S. Patent Number 5,843,014.

Anodic electrode 22 is preferably comprised of silver and cathodic electrode 24 is preferably comprised of silver chloride. Both reservoirs 26 and 28 are preferably comprised of polymer hydrogel materials as described herein. Electrodes 22,24 and reservoirs 26,28 are retained by lower housing 20. When the drug being delivered by electrotransport is cationic, the anodic reservoir 26 is the "donor" reservoir which contains the drug and the cathodic reservoir 28 contains a biocompatible electrolyte. When the drug being delivered by electrotransport is anionic, the cathodic reservoir 28 is the "donor" reservoir which contains the drug and the anodic reservoir 26 contains a biocompatible electrolyte.

52044-3

21a

The push button switch 12, the electronic circuitry on circuit board assembly 18 and the battery 32 are adhesively "sealed" between upper housing 16 and lower housing 20. Upper housing 16 is preferably composed of 5 rubber or other elastomeric material. Lower housing 20 is preferably composed of a plastic or elastomeric sheet material (e.g., polyethylene) which can be easily molded to form depressions 25,25' and cut

1 to form openings 23,23'. The assembled device 10 is preferably water
2 resistant (i.e., splash proof) and is most preferably waterproof. The system
3 has a low profile that easily conforms to the body thereby allowing freedom
4 of movement at, and around, the wearing site. The anode/drug reservoir 26
5 and the cathode/salt reservoir 28 are located on the skin-contacting side of
6 device 10 and are sufficiently separated to prevent accidental electrical
7 shorting during normal handling and use.

8 The device 10 adheres to the patient's body surface (e.g., skin) by
9 means of a peripheral adhesive 30 which has upper side 34 and body-
10 contacting side 36. The adhesive side 36 has adhesive properties which
11 assures that the device 10 remains in place on the body during normal user
12 activity, and yet permits reasonable removal after the predetermined (e.g.,
13 24-hour) wear period. Upper adhesive side 34 adheres to lower housing 20
14 and retains the electrodes and drug reservoirs within housing depressions
15 25,25' as well as retains lower housing 20 attached to upper housing 16.

16 The push button switch 12 is located on the top side of device 10 and
17 is easily actuated through clothing. A double press of the push button
18 switch 12 within a short period of time, e.g., three seconds, is preferably
19 used to activate the device 10 for delivery of drug, thereby minimizing the
20 likelihood of inadvertent actuation of the device 10.

21 Upon switch activation an audible alarm signals the start of drug
22 delivery, at which time the circuit supplies a predetermined level of DC
23 current to the electrodes/reservoirs for a predetermined (e.g., 10 minute)
24 delivery interval. The LED 14 remains "on" throughout the delivery interval
25 indicating that the device 10 is in an active drug delivery mode. The battery
26 preferably has sufficient capacity to continuously power the device 10 at the
27 predetermined level of DC current for the entire (e.g., 24 hour) wearing
28 period.

29 The present invention is particularly useful in the transformation of
30 human skin in the transdermal electrotransport delivery of drugs to humans.

1 However, the invention also has utility in delivering drugs to other animals
2 and is not limited to humans.

3 The terms "agent" and "drug" are used interchangeably herein and
4 are intended to have their broadest interpretation as any therapeutically
5 active substance which is delivered to a living organism to produce a
6 desired, usually beneficial, effect. In general, this includes therapeutic
7 agents in all of the major therapeutic areas including, but not limited to, anti-
8 infectives such as antibiotics and antiviral agents, analgesics and analgesic
9 combinations, anesthetics, anorexics, antiarthritics, antiasthmatic agents,
10 anticonvulsants, anti-depressants, antidiabetic agents, antidiarrheals,
11 antihistamines, anti-inflammatory agents, antimigraine preparations,
12 antimotion sickness preparations, antinauseants, antineoplastics,
13 antiparkinsonism drugs, antipruritics, antipsychotics, antipyretics,
14 antispasmodics including gastrointestinal and urinary antispasmodics,
15 anticholinergics, sympathomimetics, xanthine derivatives, cardiovascular
16 preparations including calcium channel blockers, beta-blockers,
17 antiarrhythmics, antihypertensives, diuretics, vasodilators including general,
18 coronary, peripheral and cerebral vasodilators, central nervous system
19 stimulants, cough and cold preparations, decongestants, diagnostics,
20 hormones, hypnotics, immunosuppressives, muscle relaxants,
21 parasympatholytics, parasympathomimetics, proteins, peptides, polypeptides
22 and other macromolecules, psychostimulants, sedatives and tranquilizers.

23 The present invention can be used to deliver transdermally by
24 electrotransport the following drugs: interferons, alfentanyl, amphotericin B,
25 angiopeptin, baclofen, beclomethasone, betamethasone, bisphosphonates,
26 bromocriptine, buserelin, buspirone, calcitonin, ciclopirox, olamine, copper,
27 cromolyn sodium, desmopressin, diclofenac diflorasone, diltiazem,
28 dobutamine, dopamine agonists, dopamine agonists, doxazosin, droperidol,
29 enalapril, enalaprilat, fentanyl, encainide, G-CSF, GM-CSF, M-CSF, GHRF,
30 GHRH, gonadorelin, goserelin, granisetron, haloperidol, hydrocortisone,
31 indomethacin, insulin, insulinotropin, interleukins, isosorbide dinitrate,

1 ketoprofen, ketorolac, leuprolide, LHRH, lidocaine, lisinopril, LMW heparin,
2 melatonin, methotrexate, metoclopramide, miconazole, midazolam, nafarelin,
3 nicardipine, NMDA antagonists, octreotide, ondansetron, oxybutynin, PGE₁,
4 piroxicam, pramipexole, prazosin, prednisolone, prostaglandins, scopolamine,
5 seglitide, sufentanil, terbutaline, testosterone, tetracaine, tropisetron,
6 vapreotide, vasopressin, verapamil, warfarin, zacopride, zinc, and zotasetron.

7 This invention is also believed to be useful in the transdermal
8 electrotransport delivery of peptides, polypeptides and other macromolecules
9 typically having a molecular weight of at least about 300 daltons, and
10 typically a molecular weight in the range of about 300 to 40,000 daltons.
11 Specific examples of peptides and proteins in this size range include, without
12 limitation, LHRH, LHRH analogs such as buserelin, gonadorelin, nafarelin
13 and leuprolide, GHRH, insulin, heparin, calcitonin, endorphin, TRH, NT-36
14 (chemical name: N=[[(s)-4-oxo-2-azetidiny]carbonyl]-L-histidyl-L-
15 prolinamide), liprecin, pituitary hormones (e.g., HGH, HMG, HCG,
16 desmopressin acetate, etc.), follicle luteoids, α ANF, growth hormone
17 releasing factor (GHRF), β MSH, TGF- β , somatostatin, atrial natriuretic
18 peptide, bradykinin, somatotropin, platelet-derived growth factor,
19 asparaginase, bleomycin sulfate, chymopapain, cholecystokinin, chorionic
20 gonadotropin, corticotropin (ACTH), epidermal growth factor, erythropoietin,
21 epoprostenol (platelet aggregation inhibitor), follicle stimulating hormone,
22 glucagon, hirulogs, hyaluronidase, interferons, insulin-like growth factors,
23 interleukins, menotropins (urofollitropin (FSH) and LH), oxytocin,
24 streptokinase, tissue plasminogen activator, urokinase, vasopressin, ACTH
25 analogs, ANP, ANP clearance inhibitors, angiotensin II antagonists,
26 antidiuretic hormone agonists, antidiuretic hormone antagonists, bradykinin
27 antagonists, CD4, ceredase, CSF's, enkephalins, FAB fragments, IgE
28 peptide suppressors, IGF-1, neuropeptide Y, neurotrophic factors, opiate
29 peptides, parathyroid hormone and agonists, parathyroid hormone
30 antagonists, prostaglandin antagonists, pentigetide, protein C, protein S,

1 ramoplanin, renin inhibitors, thymosin alpha-1, thrombolytics, TNF, vaccines,
2 vasopressin antagonist analogs, alpha-1 anti-trypsin (recombinant).

3 Generally speaking, it is most preferable to use a water soluble form
4 of the drug or agent to be delivered. Drug or agent precursors, i.e., species
5 which generate the selected species by physical or chemical processes such
6 as ionization, dissociation, dissolution or covalent chemical modification (i.e.,
7 prodrugs), are within the definition of "agent" or "drug" herein. "Drug" or
8 "agent" is to be understood to include charged and uncharged species as
9 described above.

10 While the disclosure has focussed upon the electrotransport delivery
11 of ionic species, the present invention is also applicable to the
12 electrotransport delivery of uncharged species, e.g., by electroosmosis.
13 Thus, the transformation of the skin into the high efficiency transport state is
14 not limited to electrically assisted transport of ionic species but also to
15 electroosmotic delivery of uncharged (i.e., non-ionized) species.

16 The following examples illustrate some of the advantages of the
17 present invention.

18 EXAMPLE 1

19 Current Density and Increased Efficiency

20 This study evaluated the effect of applied current on electrotransport
21 drug delivery efficiency. Drug delivery efficiency is expressed in terms of the
22 rate of drug delivery per unit of applied current. The study involved the
23 application of electrotransport devices to eighteen healthy male volunteers
24 for a duration of about one day.

25 The two electrotransport treatments involved the delivery of fentanyl
26 from a donor reservoir containing an aqueous solution of fentanyl HCl and
27 having a skin contact area of 5 cm², at a baseline current of 100 μA. Thus,
28 the applied electrotransport current density was 20 μA/cm² (= 100 μA ÷ 5
29 cm²). Six of the eighteen volunteers were administered 4 bolus doses during
30 the first hour of treatment by applying current levels of 1300 μA (i.e., an
31

1 applied electrotransport current density of $260 \mu\text{A}/\text{cm}^2$) for a duration of 2.5
2 minutes at 15 minute intervals. Following the administration of the four
3 boluses in the first hour of treatment, these six volunteers received
4 continuous transdermal electrotransport fentanyl administration at a current
5 density of $20 \mu\text{A}/\text{cm}^2$ from hour 2 through 24 hours. The remaining twelve
6 volunteers received continuous transdermal electrotransport fentanyl
7 administration at a current density of $20 \mu\text{A}/\text{cm}^2$ over the entire 24 hour
8 delivery period. After the treatment period, the electrotransport devices were
9 removed. The skin site was then washed to remove any residual fentanyl.

10 Blood samples were taken over the entire 24 hour period commencing
11 with the application of current from the electrotransport devices. Serum
12 fentanyl concentrations were used to calculate mean transdermal fentanyl
13 fluxes using subject specific pharmacokinetic parameters and conventional
14 methods.

15 FIG. 5 shows that once a skin site receives a minimum level of
16 current (for a fixed electrode area) for a sufficient duration, a high
17 electrotransport efficiency state is achieved. FIG. 5 shows the mean serum
18 fentanyl concentration in the blood of the subjects over the 24 hour testing
19 period. As is shown in the uppermost curve ($\diamond \dots \diamond \dots \diamond$) in FIG. 5, the six
20 volunteers which received the four $260 \mu\text{A}/\text{cm}^2$, 2.5 minute bolus
21 administrations in the first hour exhibited higher efficiency fentanyl
22 transdermal delivery than the group of twelve subjects shown as three
23 groups of four in the three lower curves (to emphasize inherent variability)
24 who received only the $20 \mu\text{A}/\text{cm}^2$ constant DC current. Once this high-
25 efficiency transport state is achieved, more drug is delivered through the skin
26 per unit of applied current. Further, the effect lasted the entire 24 hours of
27 the treatment. This is indicated by the vertical separation between the upper
28 curve and the three lower curves in FIG. 5.

29 Specifically, the six volunteers who received the four $260 \mu\text{A}/\text{cm}^2$
30 doses in the first hour of treatment exhibited a mean transdermal fentanyl
31 flux of $113 \mu\text{g}/\text{h}$ while the twelve volunteers who received only the $20 \mu\text{A}/\text{cm}^2$

1 baseline current exhibited a mean transdermal fentanyl flux of 57 $\mu\text{g}/\text{h}$. This
2 indicates that the efficiency was enhanced by about a factor of two as a
3 result of the initial high current density boluses.

4 5 EXAMPLE 2

6 Current Density and Fentanyl Flux

7 This study was undertaken to evaluate the relationship of current
8 density and drug flux in the transdermal electrotransport delivery of fentanyl.
9 Electrotransport devices, delivering constant DC currents, were applied to 8
10 healthy male volunteers for a duration of 24 hours. The three
11 electrotransport treatment regimens in this study differed only in the applied
12 electrotransport current (and therefore current density) levels. The
13 electrotransport devices delivered fentanyl through the skin from a donor
14 hydrogel having a skin contact surface area of 5 cm^2 . The gels were
15 imbibed with an aqueous solution of fentanyl HCl. The current density levels
16 used in this study were 10, 20, and 40 $\mu\text{A}/\text{cm}^2$. After a 24 hour treatment
17 period, the electrotransport devices were removed. The skin site was then
18 washed to remove any residual fentanyl. All 8 volunteers received each
19 treatment approximately 1 week apart.

20 For each treatment, blood samples were taken over a 24 hour period
21 commencing with the application of current from the electrotransport devices.
22 Serum fentanyl concentrations over the first 24 hours are shown in FIG. 6.
23 The top curve (-- Δ -- Δ -- Δ --) in FIG. 6 was the 200 μA treatment (i.e., 40
24 $\mu\text{A}/\text{cm}^2$), the middle curve (- \square - \square - \square -) the 100 μA treatment (i.e., 20 $\mu\text{A}/\text{cm}^2$)
25 and the bottom curve (--0--0--0--) the 50 μA treatment (i.e., 10 $\mu\text{A}/\text{cm}^2$). As
26 in Example 1, the serum fentanyl concentrations from each patient were
27 used to calculate mean drug rate and the mean total amount of drug
28 delivered. A drug delivery efficiency level for each treatment was derived by
29 dividing the mean fentanyl rate by the current density applied to the skin.

30 The average transdermal fentanyl rates were 19, 73 and 173 $\mu\text{g}/\text{h}$ at
31 the applied current densities 10, 20 and 40 $\mu\text{A}/\text{cm}^2$, respectively. This data

1 shows a non-linear relationship between applied current and transdermal
2 electrotransport drug flux within the electrotransport current density range of
3 10 to 40 $\mu\text{A}/\text{cm}^2$. An almost ten-fold increase in drug rate was observed as
4 the current was increased four-fold from 50 μA to 200 μA . This unexpected
5 result indicates that the efficiency of fentanyl delivery was enhanced by a
6 factor of about 2.5-fold due to the change in current density from 10 to 40
7 $\mu\text{A}/\text{cm}^2$.

8

9

EXAMPLE 3

10 This study was undertaken to evaluate the relationship between
11 current density and drug flux in the transdermal electrotransport delivery of
12 goserelin. The study involved the application of electrotransport devices,
13 applying constant current, to 12 normal male volunteers for a duration of 8
14 hours.

15 The two electrotransport treatment regimens in this study differed only
16 in applied current density levels. The electrotransport devices delivered
17 goserelin through the skin from polyvinyl alcohol (PVOH)-based donor
18 hydrogels having a skin-contact surface area of 4 cm^2 . The gels contained
19 an aqueous goserelin solution. The current density levels used in this study
20 were 50 and 100 $\mu\text{A}/\text{cm}^2$. After an 8 hour treatment period, the
21 electrotransport devices were removed. The skin site was then washed to
22 remove any residual goserelin. All 12 volunteers received each treatment
23 seven days apart.

24 For each treatment, seven blood samples were taken over a 24 hour
25 period commencing with the application of current from the electrotransport
26 devices. Serum goserelin concentrations from each patient were used to
27 calculate mean drug flux and the mean total amount of drug delivered.

28 FIG. 8 shows the goserelin blood plasma concentrations for the 8
29 hour duration of electrotransport administration for the two current densities
30 (i.e., 50 and 100 $\mu\text{A}/\text{cm}^2$). The 100 $\mu\text{A}/\text{cm}^2$ curve is the upper curve in FIG.
31 8 while the lower curve in FIG. 8 is the 50 $\mu\text{A}/\text{cm}^2$ data. From this

1 concentration data, transdermal goserelin fluxes were calculated. The
2 average transdermal goserelin flux was 5.8 $\mu\text{g}/\text{h}$ at an applied current
3 density of 50 $\mu\text{A}/\text{cm}^2$ while the average transdermal flux of goserelin was
4 21.6 $\mu\text{g}/\text{h}$ at an applied current density of 100 $\mu\text{A}/\text{cm}^2$. Thus, a non-linear
5 relationship between applied current density and drug flux was shown by the
6 data. An almost four-fold increase in drug flux is observed as the current
7 density rises from 50 to 100 $\mu\text{A}/\text{cm}^2$. This data also suggests the existence
8 of a critical current density, I_c , which for transdermal electrotransport delivery
9 of goserelin falls between 50 and 100 $\mu\text{A}/\text{cm}^2$, above which more drug is
10 delivered through the skin per unit of applied current.

11 The remaining example utilizes a pulsing electrotransport
12 current, and is therefore relevant only to a preferred aspect of the present
13 invention wherein the applied electrotransport current is a pulsing current
14 with current pulses having a pulse width of at least 5 msec, and more
15 preferably a pulse width of at least 10 msec.

16

17

EXAMPLE 4

18

Pulsing Frequency and Fentanyl Flux

19

20

21

This study assessed the effect of pulsing frequency on the
electrotransport delivery of fentanyl using pulsed current waveforms. The
frequencies evaluated in this study were 1, 10, and 625 Hz.

22

23

24

25

26

27

28

29

The electrotransport devices were configured to deliver a 200 μA
square wave current pulse, having a 31% duty cycle. The electrotransport
devices delivered fentanyl through the skin from a donor hydrogel having a
skin contact surface area of 2 cm^2 . Thus, during the applied electrotransport
current pulses, the current density was 100 $\mu\text{A}/\text{cm}^2$ ($= 200 \mu\text{A} \div 2 \text{cm}^2$). The
gels were imbibed with an aqueous solution of fentanyl HCl. After treatment
periods of varying duration, the electrotransport devices were removed. The
skin site was then washed to remove any residual fentanyl.

1 For each treatment, blood samples were taken commencing with the
2 application of current from the electrotransport devices. Serum fentanyl
3 levels from each patient were used to calculate mean drug flux.

4 FIG. 7 shows that the use of a square-wave frequency of 625 Hz
5 resulted in minimal fentanyl flux. This is shown in the lower most nearly
6 horizontal curve in FIG. 7. The use of the lower pulsing frequencies, 1 and
7 10 Hz, resulted in increased fentanyl flux. This is shown in the upper two
8 curves of FIG. 7. No statistically significant difference in fentanyl flux was
9 observed between 1 and 10 Hz. These results suggest that the use of lower
10 pulsing frequencies results in higher electrotransport delivery efficiency of
11 fentanyl.

12 The above disclosure will suggest many alternatives, permutations,
13 and variations of the invention to one skilled in this art without departing from
14 the scope of the invention. The above disclosure is intended to be
15 illustrative and not exhaustive. All such, permutations, variations, and
16 alternatives suggested by the above disclosure are to be included within the
17 scope of the attached claims.

52044-3

31

CLAIMS:

1. An electrotransport device for in vivo delivery of a charged agent through a body surface at a higher electrotransport agent delivery efficiency defined by the agent delivery rate per unit of applied current; the device having a donor reservoir containing the charged agent and having a delivery area, and having a source of electrical power and a current controller, the device being characterized by:
- the current controller provides an applied pulsing current having a periodic current waveform, a pulsing frequency, and a duty cycle, the pulsing current applied to the reservoir and to the body surface, wherein an applied current density is defined by the applied pulsing current divided by the delivery area, and wherein the body surface exhibits a higher electrotransport agent delivery efficiency when the applied current density is greater than or equal to a critical current density level and the applied pulsing current is applied for greater than or equal to a critical time period.
2. The device of claim 1, wherein the agent delivery efficiency is more stable when the applied current density is above the critical level and less stable when the applied current density is below the critical level.
3. The device of claim 1, wherein the device is applied to intact human skin and the controller provides an applied current density of at least $40 \mu\text{A}/\text{cm}^2$.
4. The device of claim 1, wherein the agent is fentanyl and the controller provides an applied current density of at least $40 \mu\text{A}/\text{cm}^2$ for at least about 10 msec.

52044-3

32

5. The device of claim 1, wherein the agent is goserelin and the controller varies and controls the periodic current waveform to provide an applied current density of at least $50 \mu\text{A}/\text{cm}^2$ for at least 10 msec.
- 5 6. The device of claim 1, wherein the critical time period is at least 5 msec.
7. The device of claim 1, wherein the periodic current waveform has a current magnitude that provides a second applied current density less than the critical level.
- 10 8. The device of claim 7, wherein the second applied current density is approximately zero.
9. The device of claim 7, wherein the controller varies the duty cycle and the agent delivery rate.
10. The device of claim 7, wherein the controller
15 varies the frequency and the agent delivery rate.
11. The device of claim 1, wherein the donor reservoir contains at least one suitable competitive species.
12. The device of claim 1, wherein the controller
20 varies and controls the frequency of the applied pulsing current to less than 100 Hz.
13. The device of claim 1, wherein the controller varies and controls the frequency of the applied pulsing current to less than 10 Hz.
14. A use of an electrotransport delivery device
25 having a donor reservoir containing a charged agent and having a delivery area, and having a source of electrical power and a current controller, that is for providing an

52044-3

33

applied pulsing current having a periodic current waveform,
a pulsing frequency, and a duty cycle, to the reservoir and
to the body surface for in vivo delivery of a charged agent
from the electrotransport delivery device through a body
5 surface at higher electrotransport agent delivery efficiency
defined by the agent delivery rate per unit of applied
current, wherein an applied current density is defined by
the applied pulsing current divided by the delivery area,
and wherein the body surface exhibits a higher
10 electrotransport agent delivery efficiency when the applied
current density is greater than or equal to a critical
current density level and the applied pulsing current is
applied for greater than or equal to a critical time period.

15. The use of claim 14, wherein the agent delivery
15 efficiency is more stable at a current density above the
critical level and less stable at a current density level
below the critical level.

16. The use of claim 14, wherein the device is for
applying to human skin, and the controller is for providing
20 an applied current density of at least $40 \mu\text{A}/\text{cm}^2$.

17. The use of claim 14, wherein the agent is
fentanyl, and the controller is for providing an applied
current density of at least $40 \mu\text{A}/\text{cm}^2$ for at least 10 msec.

18. The use of claim 14, wherein the pulsing frequency
25 is less than 100 Hz.

19. The use of claim 14, wherein the pulsing frequency
is less than 10 Hz.

20. The use of claim 14, wherein the duty cycle is
less than 100%.

52044-3

34

21. The use of claim 14, wherein the body surface comprises intact human skin and the critical level is at least $40 \mu\text{A}/\text{cm}^2$.

22. The use of claim 14, wherein the agent is fentanyl, the body surface is intact human skin, and the applied pulsing current is equal to the critical level which is at least $40 \mu\text{A}/\text{cm}^2$, and wherein the pulsing current is for applying for at least 10 msec.

23. The use of claim 14, wherein the agent is goserelin, and the applied pulsing current is at least $50 \mu\text{A}/\text{cm}^2$, and wherein the pulsing current is for applying for at least 10 msec.

24. The use of claim 14 wherein the controller is for varying the duty cycle and the agent delivery rate.

25. The use of claim 14 wherein the controller is for varying the pulsing frequency and the agent delivery rate.

26. The use of claim 14 wherein the donor reservoir is for receiving a suitable competitive species.

SMART & BIGGAR

OTTAWA, CANADA

PATENT AGENTS

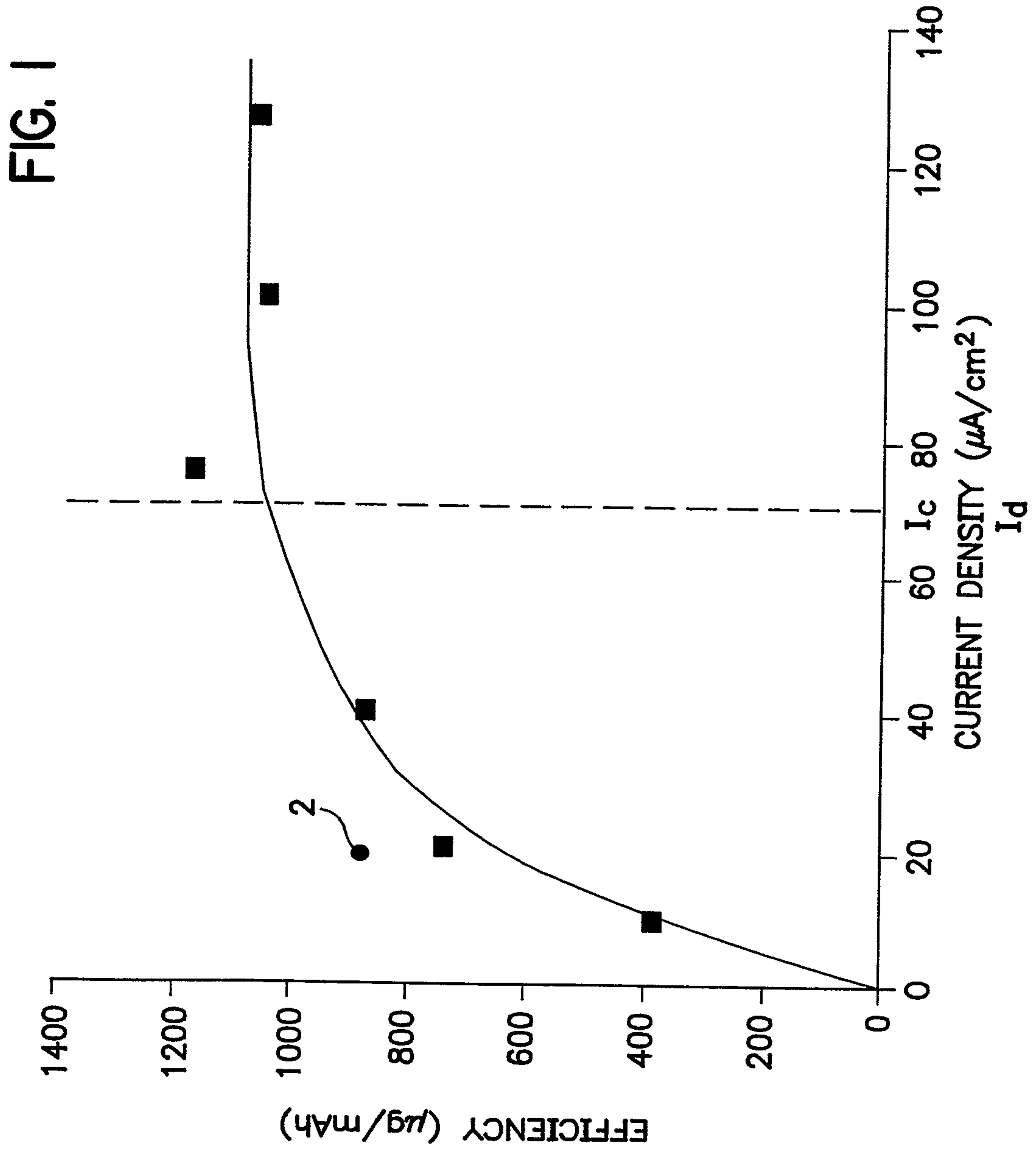

FIG. 2

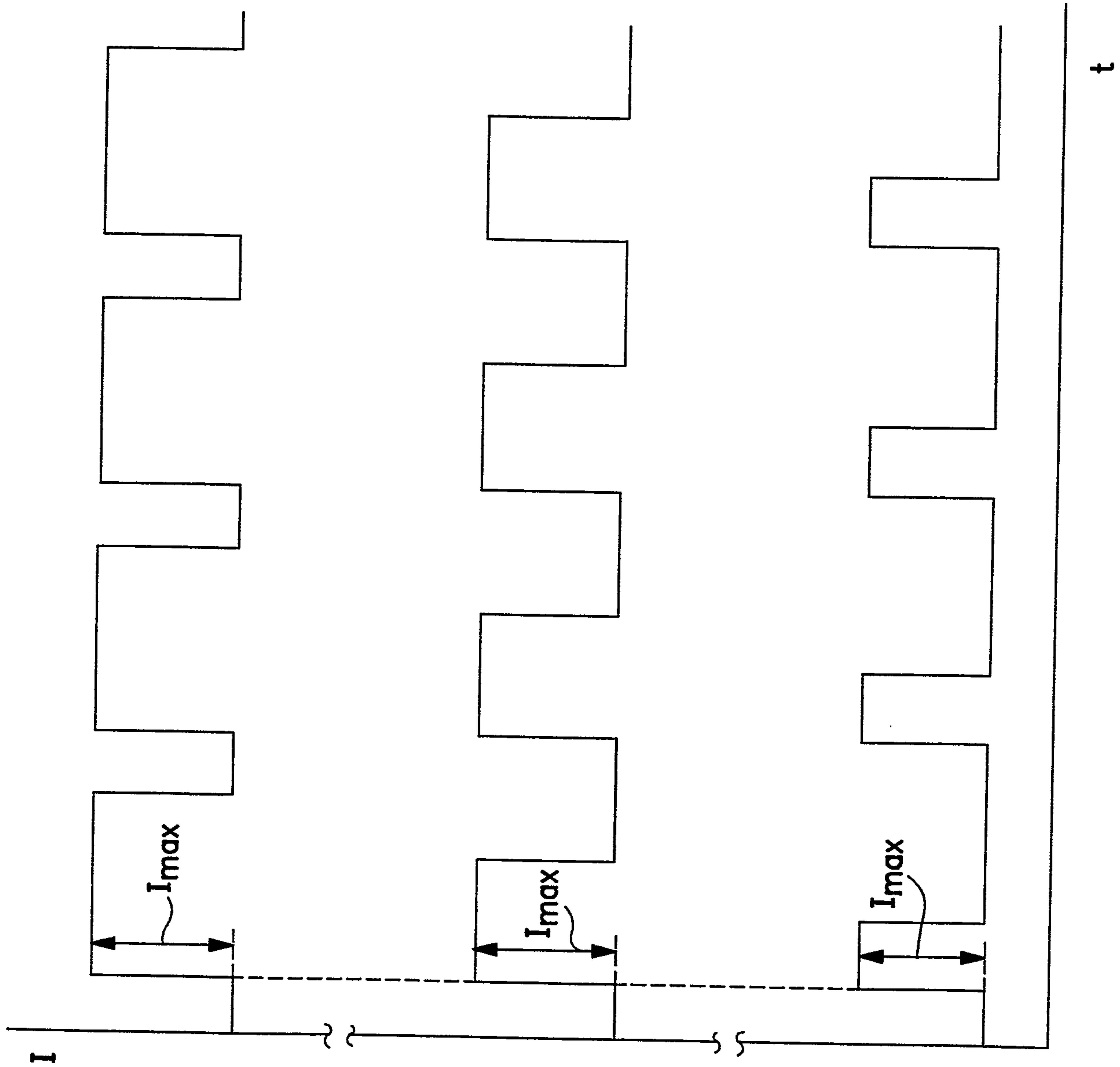

FIG. 3

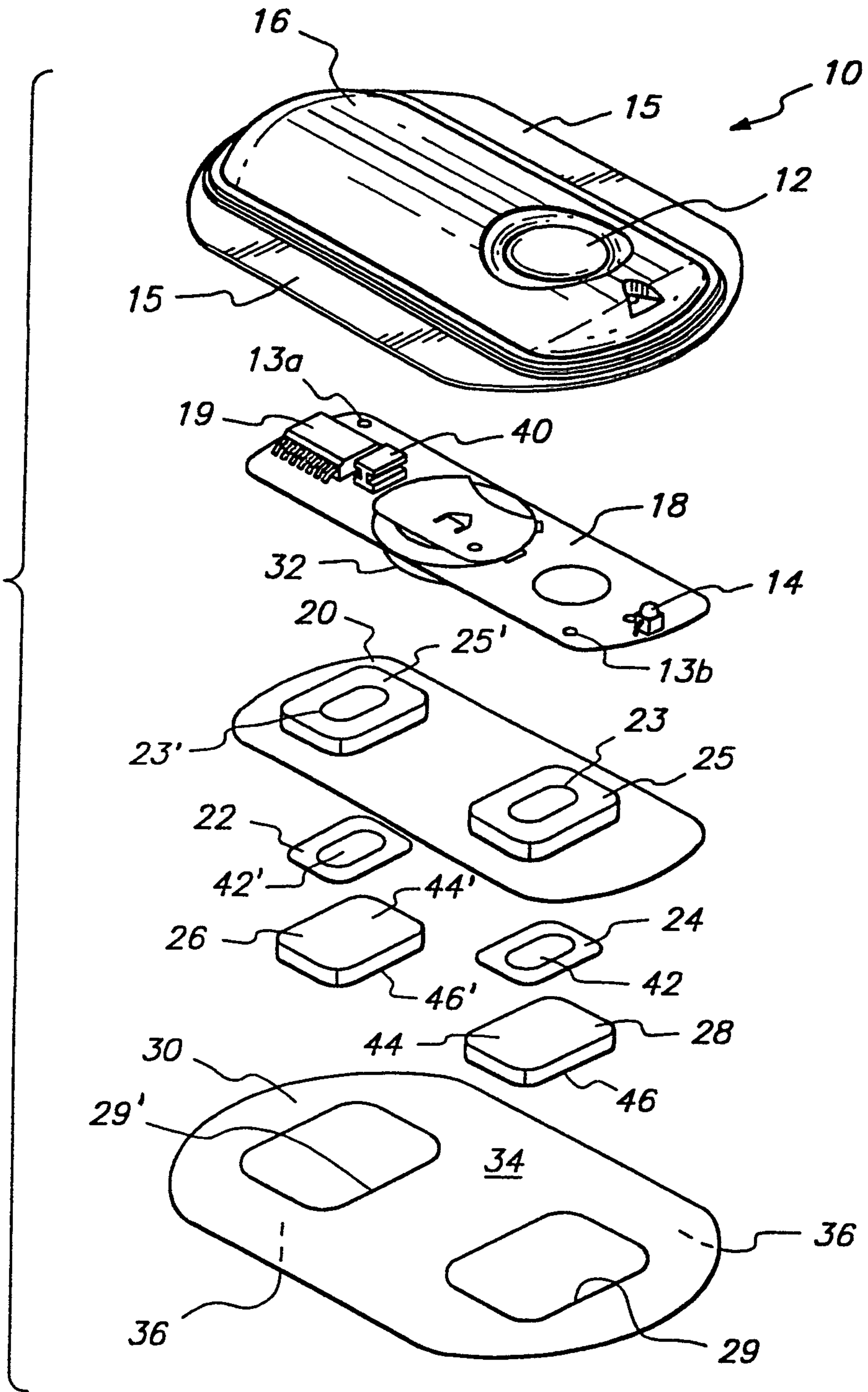

FIG. 4

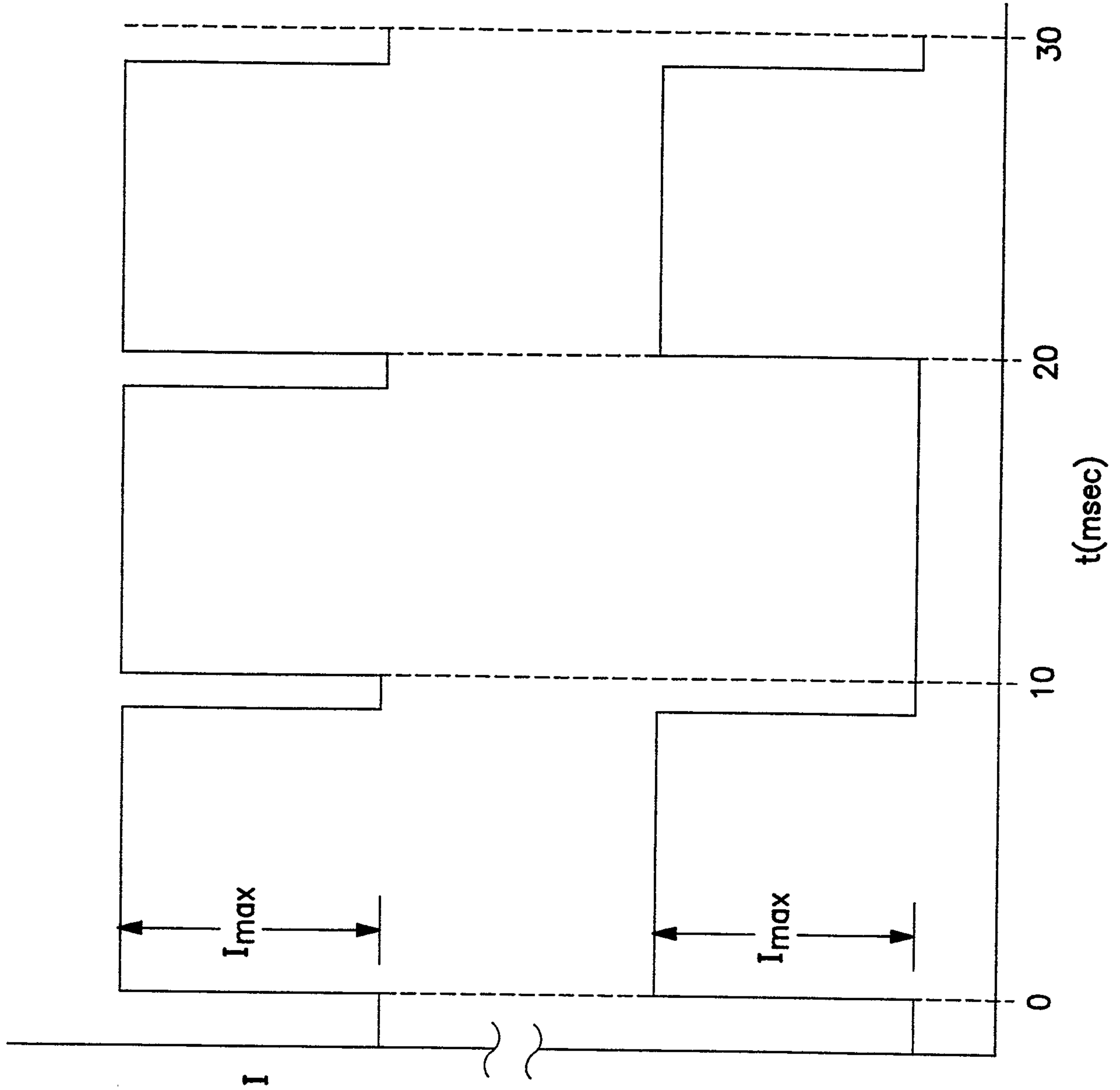

FIG. 5

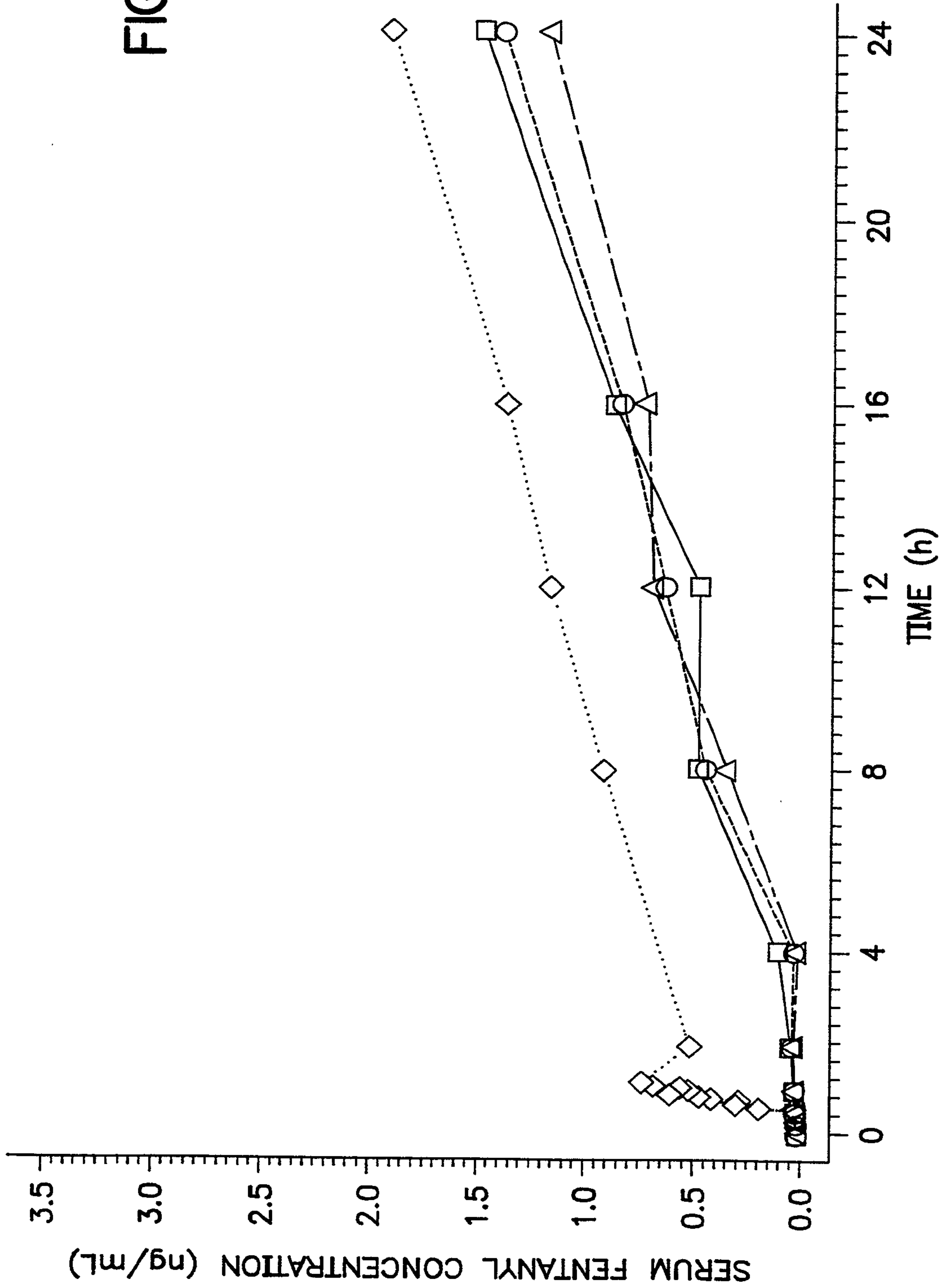
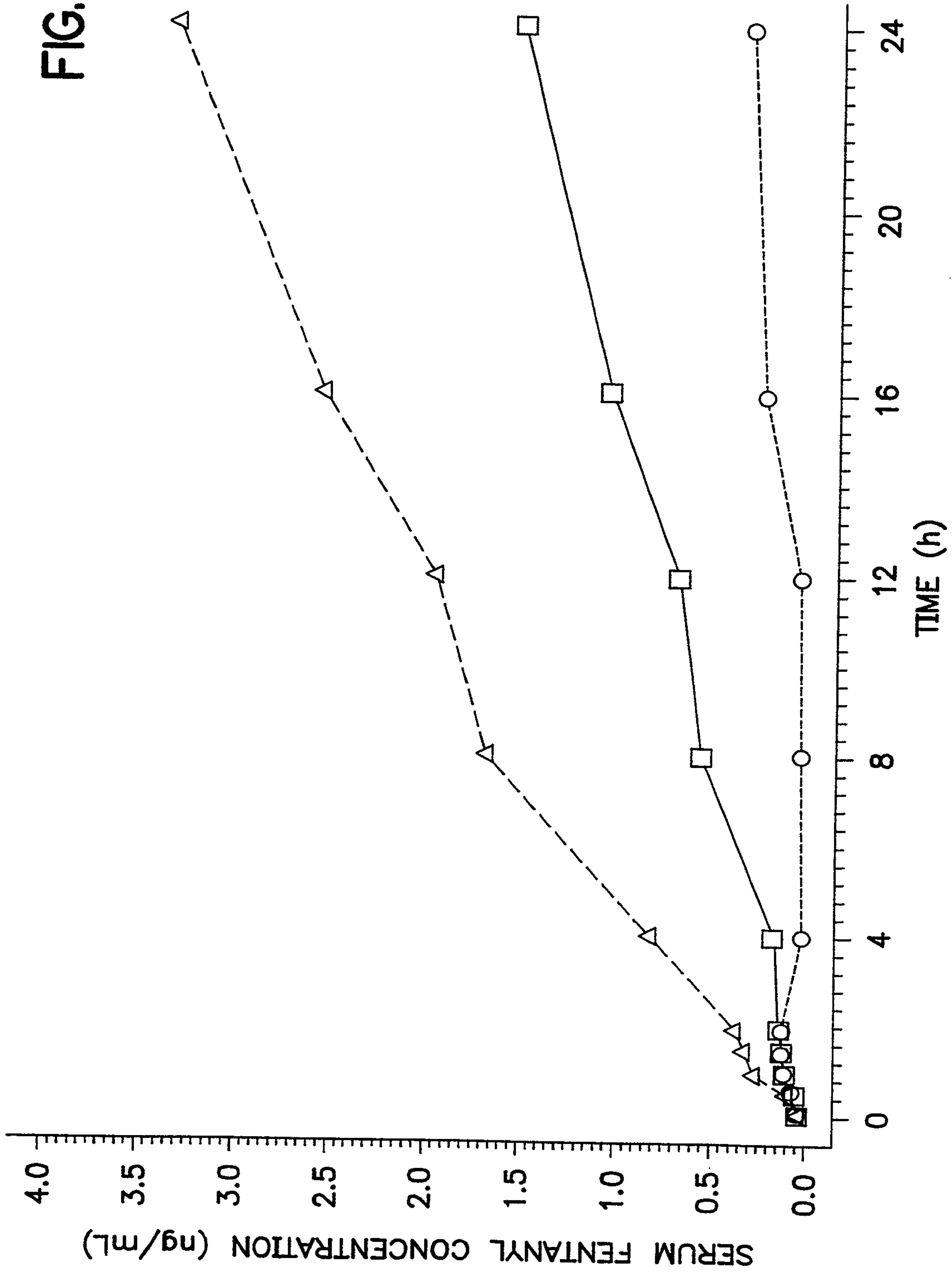

FIG. 6



7 / 8

FIG. 7

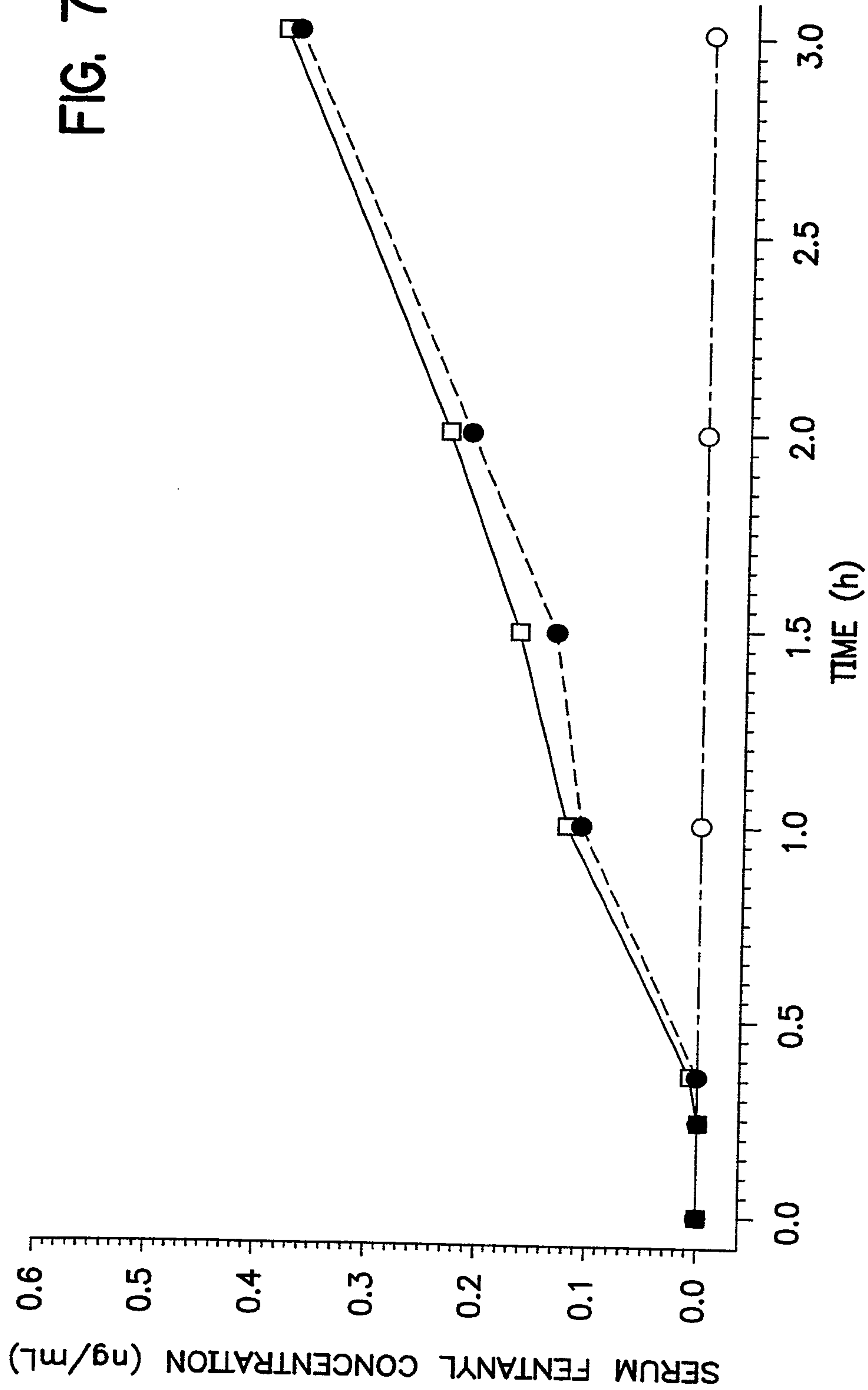

FIG. 8

