



INTERNATIONAL APPLICATION PUBLISHED UNDER THE PATENT COOPERATION TREATY (PCT)

<p>(51) International Patent Classification ⁶ : G06K 9/00</p>	<p>A1</p>	<p>(11) International Publication Number: WO 99/64981 (43) International Publication Date: 16 December 1999 (16.12.99)</p>
---	------------------	---

<p>(21) International Application Number: PCT/US99/12765 (22) International Filing Date: 8 June 1999 (08.06.99) (30) Priority Data: 09/093,549 8 June 1998 (08.06.98) US (71) Applicant: E.L. SPECIALISTS, INC. [US/US]; Suite 400, 705 N. Greenville Avenue, Allen, TX 75002 (US). (72) Inventors: BURROWS, Kenneth; 13110 Red Corral Drive, Corona, CA 91719 (US). FORD, Stuart, J.; 18706 Autumn Breeze, Spring, TX 77379 (US). (74) Agent: FORD, Stuart, J.; Vinson & Elkins L.L.P., Suite 2300, 1001 Fannin, Houston, TX 77002 (US).</p>	<p>(81) Designated States: AL, AU, BA, BB, BG, BR, CA, CN, CU, CZ, EE, GD, GE, HR, HU, ID, IL, IN, IS, JP, KP, KR, LC, LK, LR, LT, LV, MG, MK, MN, MX, NO, NZ, PL, RO, SG, SI, SK, SL, TR, TT, UA, UZ, VN, YU, ARIPO patent (GH, GM, KE, LS, MW, SD, SL, SZ, UG, ZW), Eurasian patent (AM, AZ, BY, KG, KZ, MD, RU, TJ, TM), European patent (AT, BE, CH, CY, DE, DK, ES, FI, FR, GB, GR, IE, IT, LU, MC, NL, PT, SE), OAPI patent (BF, BJ, CF, CG, CI, CM, GA, GN, GW, ML, MR, NE, SN, TD, TG).</p> <p>Published <i>With international search report.</i></p>
---	--

(54) Title: IRRADIATED IMAGES DESCRIBED BY ELECTRICAL CONTACT

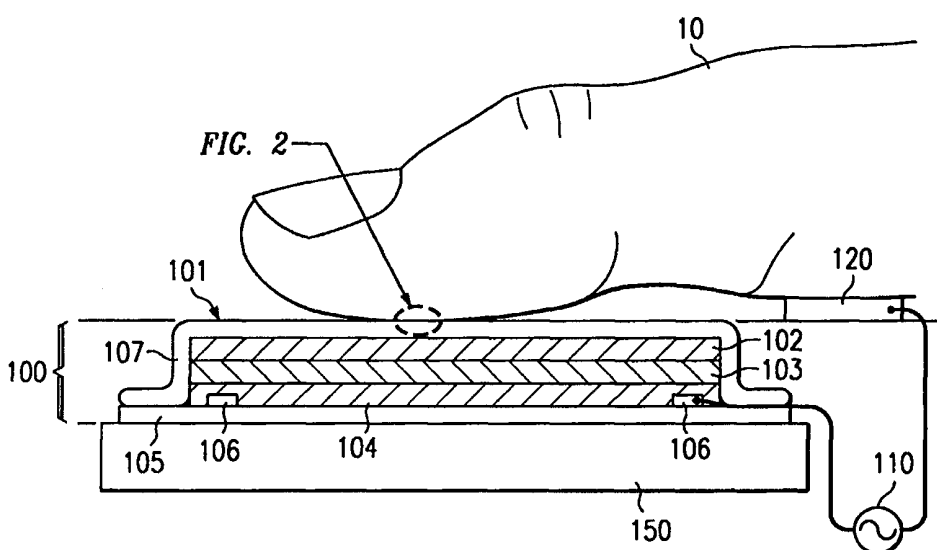

(57) Abstract

A device generating images described by contact (fig. 1, element 101), in which the contact itself closes an open circuit to generate radiation in a pattern in register with the contact. The resulting irradiated image corresponds directly to the contact pattern energizing the radiation. In a preferred embodiment enabled by an electroluminescent system (fig. 1, element 100) without a back electrode, a fingerprint is disposed to close the open circuit by making contact and thereby serving as a "temporary" back electrode. The electroluminescent then energizes in a pattern in register with the contact (fig. 1) (i.e. the fingerprint) to emit a high-resolution image of visible light with high fidelity to the contact (figs. 5a and 5b). This visible light image may then be directed onto a photosensitive array standard in the art suitable for pixelation and conversion into an electrical signal representative of the image. This signal is available for computerized storage, analysis, processing and comparison.

FOR THE PURPOSES OF INFORMATION ONLY

Codes used to identify States party to the PCT on the front pages of pamphlets publishing international applications under the PCT.

AL	Albania	ES	Spain	LS	Lesotho	SI	Slovenia
AM	Armenia	FI	Finland	LT	Lithuania	SK	Slovakia
AT	Austria	FR	France	LU	Luxembourg	SN	Senegal
AU	Australia	GA	Gabon	LV	Latvia	SZ	Swaziland
AZ	Azerbaijan	GB	United Kingdom	MC	Monaco	TD	Chad
BA	Bosnia and Herzegovina	GE	Georgia	MD	Republic of Moldova	TG	Togo
BB	Barbados	GH	Ghana	MG	Madagascar	TJ	Tajikistan
BE	Belgium	GN	Guinea	MK	The former Yugoslav Republic of Macedonia	TM	Turkmenistan
BF	Burkina Faso	GR	Greece			TR	Turkey
BG	Bulgaria	HU	Hungary	ML	Mali	TT	Trinidad and Tobago
BJ	Benin	IE	Ireland	MN	Mongolia	UA	Ukraine
BR	Brazil	IL	Israel	MR	Mauritania	UG	Uganda
BY	Belarus	IS	Iceland	MW	Malawi	US	United States of America
CA	Canada	IT	Italy	MX	Mexico	UZ	Uzbekistan
CF	Central African Republic	JP	Japan	NE	Niger	VN	Viet Nam
CG	Congo	KE	Kenya	NL	Netherlands	YU	Yugoslavia
CH	Switzerland	KG	Kyrgyzstan	NO	Norway	ZW	Zimbabwe
CI	Côte d'Ivoire	KP	Democratic People's Republic of Korea	NZ	New Zealand		
CM	Cameroon			PL	Poland		
CN	China	KR	Republic of Korea	PT	Portugal		
CU	Cuba	KZ	Kazakstan	RO	Romania		
CZ	Czech Republic	LC	Saint Lucia	RU	Russian Federation		
DE	Germany	LI	Liechtenstein	SD	Sudan		
DK	Denmark	LK	Sri Lanka	SE	Sweden		
EE	Estonia	LR	Liberia	SG	Singapore		

IRRADIATED IMAGES DESCRIBED BY ELECTRICAL CONTACT

RELATED APPLICATION

This application is related to co-pending, commonly assigned U.S. Patent application ELECTROLUMINESCENT SYSTEM IN MONOLITHIC STRUCTURE, Serial No. 08/656,435, filed May 30, 1996, the disclosure of which application is incorporated herein by reference.

TECHNICAL FIELD OF THE INVENTION

This invention relates generally to devices generating images of contact (such as fingerprints), and more specifically to a device that causes a pattern of contact itself to selectively close an open circuit, where such closure of the circuit energizes an irradiated image directly in register with the contact pattern.

BACKGROUND OF THE INVENTION

Devices are known in the art to capture images described by contact on a surface. A primary, although by no means exclusive, application for such imaging devices is in the area of fingerprinting, whether for security, forensics or other purposes. Other applications include analysis of surface texture for classification or testing purposes, or recording contact for archival purposes, or possibly mechanical duplication.

All of the foregoing applications involve translating the image described by contact into a reproducible record of the image. For example, in the fingerprint application, a time-honored system is to "ink" the fingers and roll them on a paper or card surface. Of course, without further scanning of the results, such systems lack the capability to generate computer-ready signals representative of the images. Without the storage and analysis capabilities of a computer, cataloging and comparison of such fingerprint images is a time-consuming and unpredictable task.

More recent devices shine light onto the fingerprint via a prism. The reflected image may be captured on photosensitive film, or received onto a photosensitive array. In the latter case, the image may then be pixelated and stored as an analog or digital signal representative of the image. These signals are now available for further processing by computers.

The prior art references cited with this disclosure demonstrate that fingerprinting is a popular application of the "reflected image" technique. The same "reflected image" technique is also known to be used to scan paper or other textile images into scanners and photocopiers.

The disadvantage with all devices employing a "reflected image" technique of recording images is that by definition they need an independent light source and optical structure (such as a prism) to create a reflected image. The same is true of "reflected image" techniques using radiation outside the visible light band of the electromagnetic spectrum. By definition, an independent radiation source and reflective/diffractive structure is still required.

Other current art devices generating images by contact use proximity sensors to detect changes in characteristics such as capacitance or magnetic flux. The disadvantages of these devices are that (1) they can be unreliable, and (2) they can be costly. They are unreliable inasmuch that in detecting variations in, say, capacitance, there is no way to know whether capacitance change is caused by contact or by some other stray source. Further, an expense must be incurred in such devices in creating sensor circuitry having fidelity and resolution comparable to the capability of capturing and resolving reflected radiation such as visible light.

There is therefore a need in the art for a device generating images described by contact, where the contact is the primary source of energy for the image itself. In this way, the extra structure required in "reflected image" techniques would be obviated. Further, it would be highly advantageous if such an inventive device did not rely on proximity sensors to detect the contact. The inventive device would then have increased predictability in performance, without requiring complex sensor circuitry to interpret the contact.

SUMMARY OF THE INVENTION

These and other objects, features and technical advantages are achieved by an invention that generates images described by contact, in which the contact itself closes an open circuit to generate radiation in a pattern in register with the contact. In this way, an irradiated image results, which corresponds directly to the contact pattern energizing the radiation.

The invention thus has immediate (although not exclusive) application to fingerprinting techniques. In a preferred embodiment enabled by an electroluminescent system without a back electrode, a fingerprint is disposed to close the open circuit by making contact and thereby serving as a "temporary" back electrode. The electroluminescent system then energizes in a pattern in register with the contact (i.e. the fingerprint) to emit a high-resolution image of visible light with high fidelity to the contact. This image may then be directed on to a photosensitive array standard in the art suitable for pixelation and conversion into an electrical signal representative of the image. This signal is available for computerized storage, analysis, processing and comparison.

Advantageously, the electroluminescent system enabling a preferred embodiment is a low cost, screen-printed polymer thick film ("PTF") lamp, which may be electrically powered at a low AC voltage (say 20 - 30 volts AC) at frequencies in a range of 400 Hz to 2 kHz. Such a power supply is well known in the art to be available from low voltage integrated circuit inverters (say 3 - 5 volts DC). The electroluminescent system will then be very safe to the touch by virtue of the very low current levels generated by such an electrical system.

Of course, it will be appreciated that the invention is in no way limited to fingerprinting applications. According to the invention, any form of electrically conductive contact will describe an irradiated image. Thus, the surface textures of many objects, animate or inanimate, may be imaged with the invention.

Further, the invention is not limited to contact generating visible light via electroluminescence. Although the preferred embodiment as described is highly advantageous, the invention in its broadest form encompasses generating irradiated

imaged described by contact, where the contact itself closes an open circuit to energize radiation in register with the contact. Thus, generation of any radiation in the electromagnetic spectrum falls within the scope of the invention. For example, an infra-red image could be generated by an open circuit where heat is emitted in pattern in register with selective closure of the circuit by the contact. Clearly, yet further fidelity and resolution of images described by contact may be available through selection of the wavelength of the radiation generated by the invention, as may be compatible with the device receiving and interpreting the irradiated image.

Similarly, the use of electroluminescence in the preferred embodiment should not be considered as limiting. Clearly, using the contact to form the back electrode of an electroluminescent lamp is a highly advantageous enablement of radiation in register with contact. The invention, however, is broad in concept in that it uses the contact itself to close an open circuit to energize radiation in register with the contact. Thus, it will be appreciated that the invention is enabled by any open circuit capable of generating radiation in register with selective closure of the circuit by a pattern of contact.

It is therefore a technical advantage of the present invention to generate an irradiated image corresponding to contact, by causing the contact to close an open circuit, thereby obviating the need for additional apparatus such as an independent radiation source and reflective/diffractive structure to enable a "reflected image."

It is a further technical advantage of the invention to eliminate the unpredictability and potential manufacturing complexity of devices using "proximity sensor" structure to generate an image of contact.

A yet further technical advantage of the invention is that it can be enabled reliably and economically on a screen-printed PTF electroluminescent lamp, where the contact forms the back electrode of the lamp. Visible light in a pattern in register with the contact may then be radiated towards a photosensitive array. This array in turn may pixelate the image and prepare a computer-ready signal corresponding to the image.

The foregoing has outlined rather broadly the features and technical advantages of the present invention in order that the detailed description of the invention that follows may be better understood. Additional features and advantages of the invention will be described hereinafter which form the subject of the claims of the invention. It should be appreciated by those skilled in the art that the conception and the specific embodiment disclosed may be readily utilized as a basis for modifying or designing other structures for carrying out the same purposes of the present invention. It should also be realized by those skilled in the art that such equivalent constructions do not depart from the spirit and scope of the invention as set forth in the appended claims.

BRIEF DESCRIPTION OF THE DRAWINGS

For a more complete understanding of the present invention, and the advantages thereof, reference is now made to the following descriptions taken in conjunction with the accompanying drawings, in which:

5 FIGURE 1 is a section view through a preferred embodiment of the present invention;

 FIGURE 1A is a section view through an alternative embodiment of the present invention;

 FIGURE 2 is an enlargement of contact as shown on FIGURES 1A and 1B.

10 FIGURE 3 is a cutaway view of the embodiment of the invention illustrated on FIGURE 1;

 FIGURE 4 depicts the invention in operation; and

 FIGURES 5A and 5B are actual thumb print images obtained using the preferred embodiment.

DETAILED DESCRIPTION OF THE INVENTION

As described summarily above, the present invention is directed to an apparatus capable of emitting radiation corresponding to zones of contact on a surface, where the contact physically closes an open electrical circuit, and where the closure of the circuit energizes the radiation in a pattern in register with the contact to a high degree of fidelity and resolution. This apparatus is particularly advantageous in generating fingerprint, palm print, footprint or other skin images where the skin is electrically conductive. A preferred embodiment will be discussed with reference to generating a visible light image of a human thumb print, although as already discussed, the invention is not limited in this regard. Skin images of other anatomical regions of humans, as well as other life forms, may be generated by the invention, so long as the skin whose contact is described by the image is electrically conductive. Further, the invention is not limited to generating images of anatomical contact. It will be appreciated that the other embodiments of the invention may generate irradiated images described by contact on a contact surface by any electrically conductive zone wherein a previously open circuit is now closed by the contact. Accordingly, images corresponding to, for example, metal surface textures, or "water marks" on electrically conductive fabrics, textiles or papers may be generated by the invention with equivalent enabling effect.

The preferred embodiment will further be discussed with reference to generating visible light using an open electroluminescent system closed by contact by a thumb print on a contact surface. It will nonetheless be further appreciated, however, that the invention is not limited in this regard. Consistent with the invention, the area of contact may be described by radiation anywhere in the electromagnetic spectrum, and not just in the visible light band as enabled by the preferred embodiment discussed below. Imagery in, for example, the infra-red, ultra-violet bands is consistent with the invention where irradiated images of such emissions have useful applications.

Likewise, the use of an open electroluminescent circuit in a preferred embodiment should not be considered as limiting under the invention. Electroluminescence has useful applications in the visible light band because an open

Electroluminescence has useful applications in the visible light band because an open circuit can be deployed easily and economically in the form of a laminate, where the contact to be imaged can form a back electrode, thereby closing the circuit and generating light in register with the contact. It will be appreciated, however, that other forms of circuitry will be consistent with the invention where contact closes an open circuit to generate corresponding irradiated images outside of the visible light band. For example, consistent with the invention, heat could be generated in register with the passage of current through a circuit closed by contact. Accordingly, circuitry generating infra-red radiation in register with circuit-closing contact will be enabled by the invention. Thus, by selecting various radiation-generating components in the open circuit to be closed by contact, other types of circuits will enable the invention.

Turning now to FIGURE 1, a general arrangement of the preferred embodiment includes human thumb 10 making thumb print contact on a contact surface 101 on electroluminescent system 100. Thumb 10 also concurrently makes electrical contact with contact plate 120, contact plate 120 being isolated electrically from electroluminescent system 100.

With further reference to FIGURE 1, electroluminescent system 100 comprises substrate 105 on which translucent electrode layer 104 is deposited. In a preferred embodiment, substrate 105 may be any suitable material allowing the passage of visible light, such as polyester, polycarbonate, vinyl or elastomer.

In a preferred embodiment, the active ingredient doped into translucent electrode layer 104 is Indium-Tin-Oxide ("ITO"), although any other functionally equivalent transparent metal oxide dopant known in the art may be used, such as, for example, Tantalum-Oxide. In another embodiment (not illustrated) substrate 105 and translucent layer 104 may be combined using a pre-sputtered ITO polyester sheet. Translucent electrode layer 104 also includes bus bar 106 connected to power source 110. Although shown in section on FIGURE 1, it will be appreciated that bus bar 106 is continuous within translucent electrode layer 104 so as to energize the planar area of the layer. In a preferred embodiment, bus bar 106 is screen printed on to a substrate 105, using a silver polymer thick film (PTF) ink, prior to screen printing of

translucent electrode layer on to substrate 105. It will be appreciated, however, that bus bar 106 is not limited in this way, and may also be, for example, a thin copper strip adhered to substrate 105 prior to depositing translucent electrode layer 104. Of course, if pre-sputtered ITO polyester sheet is used to combine substrate 105 and
5 translucent electrode layer 104 (not illustrated), then bus bar 106 may be eliminated.

Continuing to refer to FIGURE 1, contact surface 101 is on top of envelope layer 107. Envelope layer is an electrically conductive layer protecting electroluminescent system 100. Advantageously, envelope layer 107 is a hard wearing material so as to give contact surface 101 a long life. Examples of materials
10 suitable for envelope layer 107 when the invention is practiced in accordance with screen printing techniques as described further below are epoxies, polyurethanes, acrylics and other similar hard wearing materials.

Envelope layer 107 and translucent electrode layer 104 are separated by dielectric layer 102 and luminescent layer 103. In a preferred embodiment, the layer
15 sequence is as shown in FIGURE 1, where luminescent layer 103 is closer to substrate 105 than dielectric layer 102. The invention would still be enabling if luminescent layer 103 and dielectric layer 102 were reversed. Light irradiated from luminescent layer 103 would then have to pass through dielectric layer 102 to reach substrate 105, however, possibly with disadvantageous effects such as energy loss, diffusion or
20 diffraction. Accordingly, a preferred embodiment arranges the layers as shown in FIGURE 1.

In a preferred embodiment, the active ingredient in dielectric layer 102 is Barium-Titanate and in luminescent layer 103 is encapsulated Phosphor. Inks doped with these ingredients are screen printed down on top of each other before envelope
25 layer 107 is screen printed down to seal the system. Note that for optimum results, luminescent layer 103 should be deposited extremely evenly to generate a constant and predictable light emission by contact at any point on contact surface 101.

FIGURE 1A depicts an alternative embodiment in which envelope layer 107 on FIGURE 1 is omitted, its function replaced by a hard wearing dielectric layer
30 102A. In FIGURE 1A, therefore, contact surface 101A is on dielectric layer 102A.

Dielectric layer 102A on FIGURE 1A is advantageously comprised of Barium-Titanate doped into a screen printed layer of epoxy, the epoxy selected as the binder for hard-wearing and environmental-resisting life. The advantage of the embodiment according to FIGURE 1A, of course, is that it has less components and so is therefore more economical to manufacture. The disadvantage compared to the embodiment of FIGURE 1, however, is that as dielectric layer 102A wears from use, the layer itself deteriorates. Ultimately, as wear continues, this may directly affect the luminescent fidelity of the inventive apparatus in describing contact on contact surface 101A. To prepare and prolong the life of the system depicted on FIGURE 1A, therefore, additional catalytic cross-linking of the system is highly advantageous, using chemical or ultra-violet treatment techniques known in the art.

Returning now to FIGURE 1, it will be seen that electroluminescent system 100 is incomplete inasmuch that it lacks a back electrode. Further, when power source 110 is coupled between bus bar 106 and contact plate 120 as shown in FIGURE 1, an open circuit results, stretching from contact surface 101, through electroluminescent system 100, and round to contact plate 120 via power source 110.

According to the present invention, and as shown on FIGURE 1, thumb 10 completes the open circuit, by concurrently touching contact plate 120 and making thumb print contact with contact surface 101. It will be appreciated that contact plate 120 is but one choice of enabling electrical contact with thumb 10, and other methods (such as a wire attached by an electrode) would have an equivalent enabling effect.

Of particular inventive significance, however, is that thumb 10 makes thumb print contact with contact surface 101. As enlarged on FIGURE 2, thumb 10 makes selective zones of contact C in a pattern described by ridges 201 touching contact surface 101, while valleys 202 remain clear. The open circuit described above with respect to FIGURE 1 is thus selectively closed in a pattern in register with zones of contact C. This circuit in turn causes electroluminescent system 100 to energize in a pattern in register with zones of contact C, so that luminescent layer irradiates a visible light image with high fidelity and resolution to zones of contact C. In the

embodiment of the invention shown on FIGURE 1, this irradiated image is projected downwards through substrate 105.

FIGURE 1 also shows photosensitive array 150 immediately below substrate 105. Photosensitive array 150 may then pixelate the irradiated image described by zones of contact C on FIGURE 2 into electrical signals representative of the image. These signals may be processed further according to the application for the inventive apparatus.

Referring back to discussion at the beginning of this section, therefore, it will be seen that thumb 10 on FIGURE 1 may be substituted for other electrically conductive structures whose surface texture can be described by an irradiated image via contact with contact surface 101. Moreover, although FIGURE 1 has described an electroluminescent system generating a visible light image describing zones of contact C on the contact surface 101, a broader aspect of the invention is that irradiated images are generated by selectively completing an open electric circuit in register with the contact. Thus, as described earlier, other forms of radiation generated via selective closure of other types of open circuit fall within the scope of the invention.

FIGURE 3 illustrates the invention in cutaway view. As suggested earlier, a preferred embodiment of the invention deploys electroluminescent system 100 (as shown on FIGURE 1) by successively screen printing layers according to the described laminate. Advantageously, screen printing techniques such as described and enabled in great detail in commonly-assigned, co-pending U.S. patent application "ELECTROLUMINESCENT SYSTEM IN MONOLITHIC STRUCTURE," serial number 08/656,435, filed May 30, 1996, the disclosure of which application is fully incorporated herein by reference, will be used to enable the present invention. Specifically, materials, quantities and techniques disclosed in the above-referenced co-pending application using a vinyl resin carrier in gel form will enable a hard-wearing electroluminescent laminate suitable for the thumb print application described herein.

FIGURE 4 illustrates the irradiated image R of the invention described by thumb print contact of thumb 10 on contact surface 101. In FIGURE 4, image R is

passing through to photosensitive array 150 as described above with reference to FIGURE 1.

FIGURES 5A and 5B are representations of thumb print images irradiated in accordance with the preferred embodiment as described herein, as captured by a digital camera. The high degree of fidelity and resolution will be appreciated.

With reference to the preferred embodiment, application-specific adjustment of layer thickness of the electroluminescent system may be necessary, in combination with corresponding adjustment of power source parameters and dopant concentrations, in order to maximize fidelity, contrast and resolution. For example, in the thumb print generator described herein using an electroluminescent system detailed in above-referenced co-pending U.S. application "ELECTROLUMINESCENT SYSTEM IN MONOLITHIC STRUCTURE," power source 110 on FIGURE 1 should generate at least 20 volts AC at approximately 1.5 kHz. Note, however, that a voltage in excess of 50 volts AC may generate an electrical sensation to an adult human user, albeit harmless at the levels of current generated by the apparatus. Power source requirements will also vary with the physical size of the irradiated image expected to be described by contact. For example, in the arrangement described above, experimentation has shown 20 volts AC at 1.5 kHz generates a satisfactory image for a human fingerprint or thumb print, while 30 volts AC at 2 kHz is needed for a satisfactory palm print image.

Note that from an applications standpoint, integrated circuit chip-based inverter modules convert low direct current voltages (3 volts to 5 volts) to the suggested alternating current voltages and frequencies described. The low currents generated by these modules are ideal for PTF electroluminescent systems and are very safe for human use.

Although the present invention and its advantages have been described in detail, it should be understood that various changes, substitutions and alterations can be made herein without departing from the spirit and scope of the invention as defined by the appended claims.

CLAIMS

We claim:

1. A method for generating an image describing selective contact, comprising:

(a) deploying a open electric circuit across a receiving surface, the circuit including a source of radiation energizable upon closure of the electric circuit;

5 (b) touching the receiving surface with a contact surface, wherein said touching is effective to selectively close the electric circuit in a pattern in register with zones of contact between the contact surface and the receiving surface; and

(c) responsive to said selective closure of the electric circuit, generating an image corresponding to said zones of contact, the image comprising radiation energized in said pattern.

2. A method for generating an image describing selective contact, comprising:

(a) providing a laminate, the laminate including an outer receiving surface, a luminescent layer, a dielectric layer and a translucent electrode layer, the receiving surface on the laminate separated from the translucent electrode layer by the dielectric layer and the luminescent layer;

(b) connecting a power source to the translucent electrode layer;

5 (c) touching the receiving surface with a contact surface, wherein said touching is effective to selectively couple the power source through the contact surface and across the laminate in a pattern in register with zones of contact between the contact surface and the receiving surface; and

10 (d) responsive to said selective coupling, energizing the luminescent layer so as to generate light in said pattern.

3. The method of claim 2, in which the contact surface is topographically uneven.

4. The method of claim 2, in which the laminate is a polymer thick film laminate deposited using a screen-printed process.

5. The method of claim 4, in which the laminate is developed by depositing successive layers suspended in a vinyl resin carrier in gel form.

6. Apparatus for generating an electroluminescent image describing contact on an electroluminescent system by an independent contact surface, comprising:

5 a laminate, the laminate having an outer receiving surface, the laminate including a luminescent layer, a dielectric layer and a translucent electrode layer, the laminate further disposed so that the receiving surface is separated from the translucent electrode layer by the dielectric layer and the luminescent layer;

means for concurrently connecting a power source to the translucent electrode and to the contact surface; and

10 means for selectively coupling the power source across the laminate in a pattern in register with zones of contact between the contact surface and the receiving surface, wherein responsive to said selective coupling, the luminescent layer generates light in said pattern.

7. The apparatus of claim 6, in which the contact surface is topographically uneven.

8. The apparatus of claim 6, in which the contact surface is a fingerprint.

9. The apparatus of claim 6, in which the laminate is a polymer thick film laminate.

10. The apparatus of claim 6, in which selected ones of the translucent electrode, dielectric and luminescent layers are deposited using a screen printing process.

11. The apparatus of claim 6, in which selected neighboring ones of the translucent electrode, dielectric and luminescent layers are suspended in a unitary gel vehicle prior to deposition thereof.

12. The apparatus of claim 6, in which the means for connecting the power source to the translucent electrode layer includes a bus bar layer in the laminate, the laminate further disposed so that the translucent electrode layer separates the bus bar layer from the receiving surface.

13. The apparatus of claim 6, in which the means for connecting the power source to the contact surface includes an electrode disposed in physical proximity to the receiving surface so that the contact surface can touch the electrode concurrently with making contact with the receiving surface.

14. The apparatus of claim 6, in which the translucent electrode layer includes indium-tin-oxide as an active ingredient.

15. The apparatus of claim 6, in which the dielectric layer includes barium-titanate as an active ingredient.

16. The apparatus of claim 6, in which the luminescent layer includes encapsulated phosphor as an active ingredient.

17. Apparatus for generating an electroluminescent image describing contact on an electroluminescent system by a fingerprint, comprising:

a polymer thick film laminate, the laminate having an outer receiving surface, the laminate comprising:

- 5 a dielectric layer including barium-titanate as an active ingredient;
- a luminescent layer including encapsulated phosphor as an active ingredient;
- 10 a translucent electrode layer including indium-tin-oxide as an active ingredient; and
- a bus bar layer;

15 the laminate further disposed so that (1) the receiving surface is separated from the translucent electrode layer by the dielectric layer and the luminescent layer, and (2) the translucent electrode layer separates the bus bar layer from the receiving surface;

means for concurrently connecting a power source to the bus bar and to the fingerprint, the means for connecting to the fingerprint including an electrode disposed in physical proximity to the receiving surface so that the fingerprint can touch the electrode concurrently with making contact with the receiving surface; and

20 means for selectively coupling the power source across the laminate in a pattern in register with zones of contact between the fingerprint and the receiving surface, wherein responsive to said selective coupling, the luminescent layer generates light in said pattern.

18. The apparatus of claim 17, in which selected ones of the translucent electrode, dielectric and luminescent layers are deposited using a screen printing process.

19. The apparatus of claim 17, in which selected neighboring ones of the translucent electrode, dielectric and luminescent layers are suspended in a unitary gel vehicle prior to deposition thereof.

20. The apparatus of claim 17, in which the power source generates between 20 volts and 40 volts AC, at a frequency in the range of 1.5 kHz and 2 kHz.

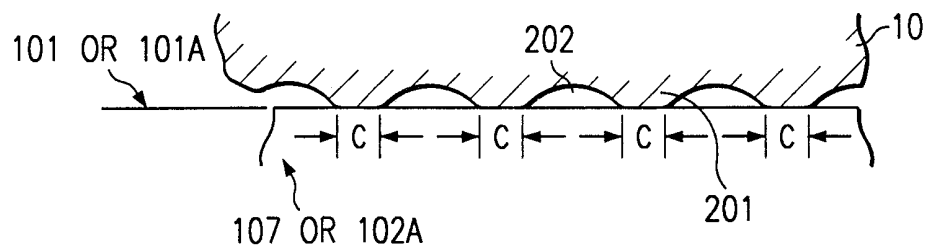
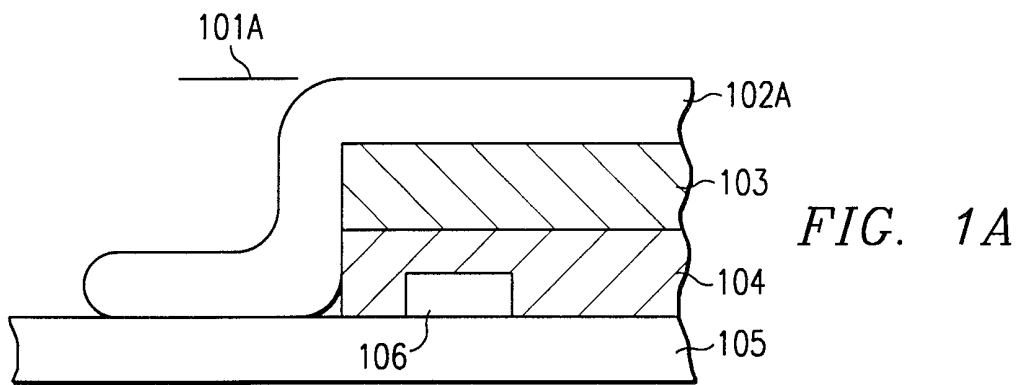
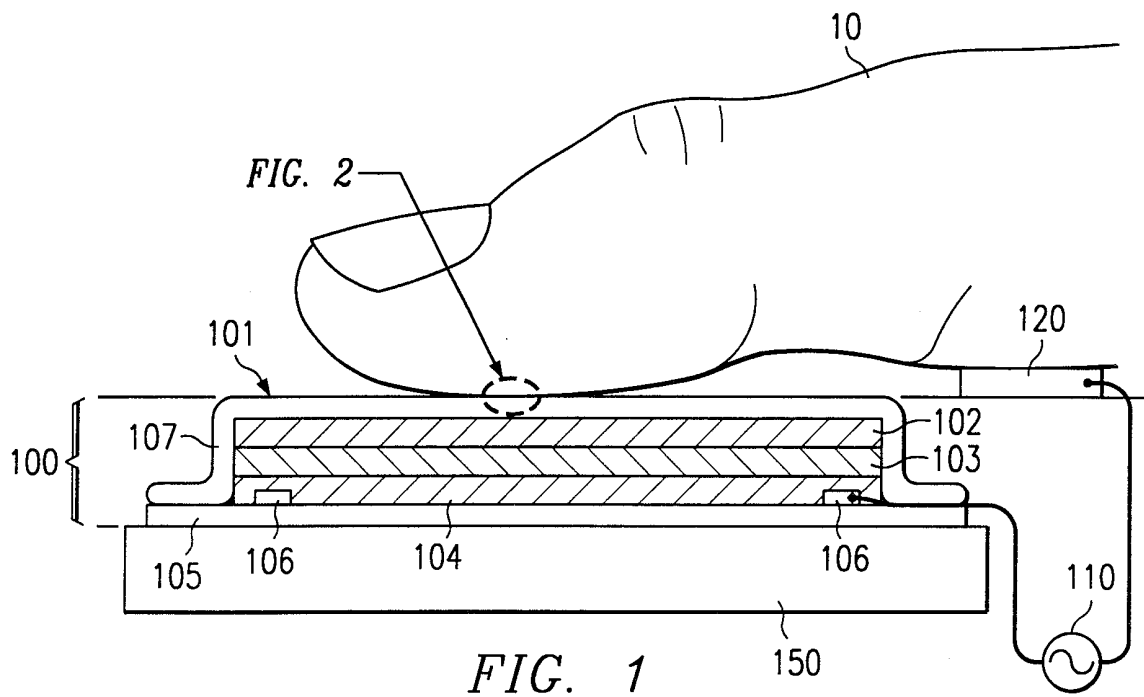

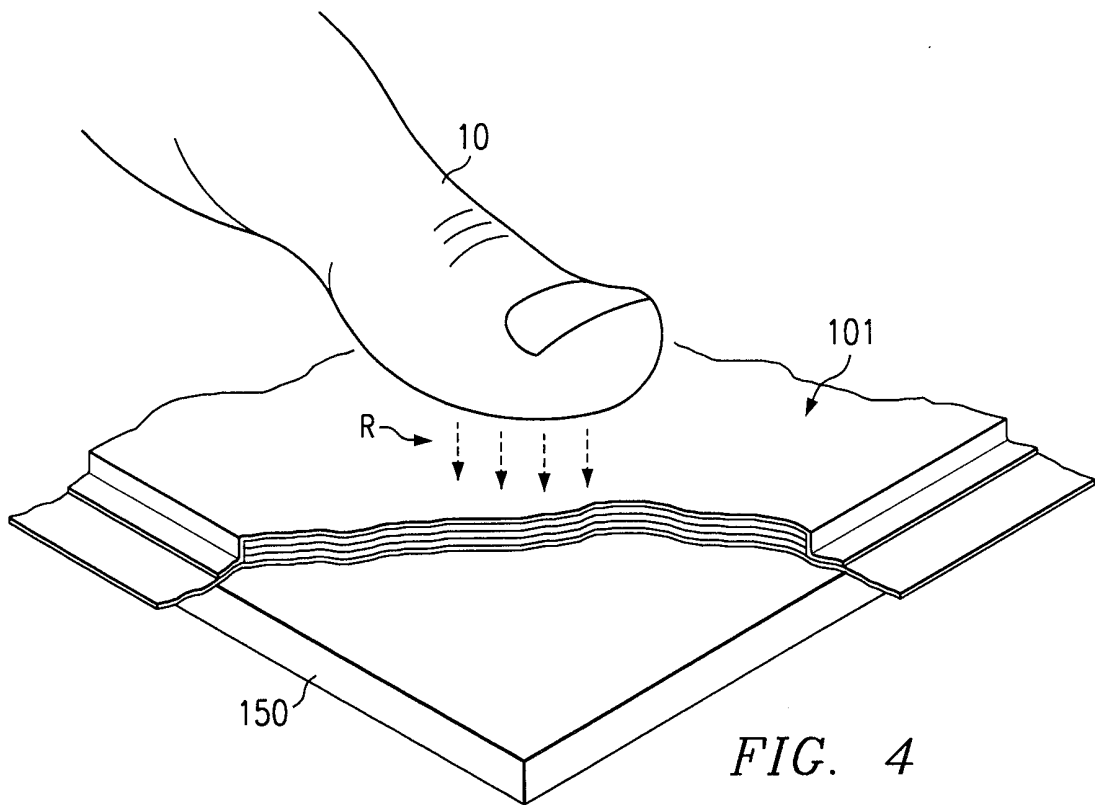
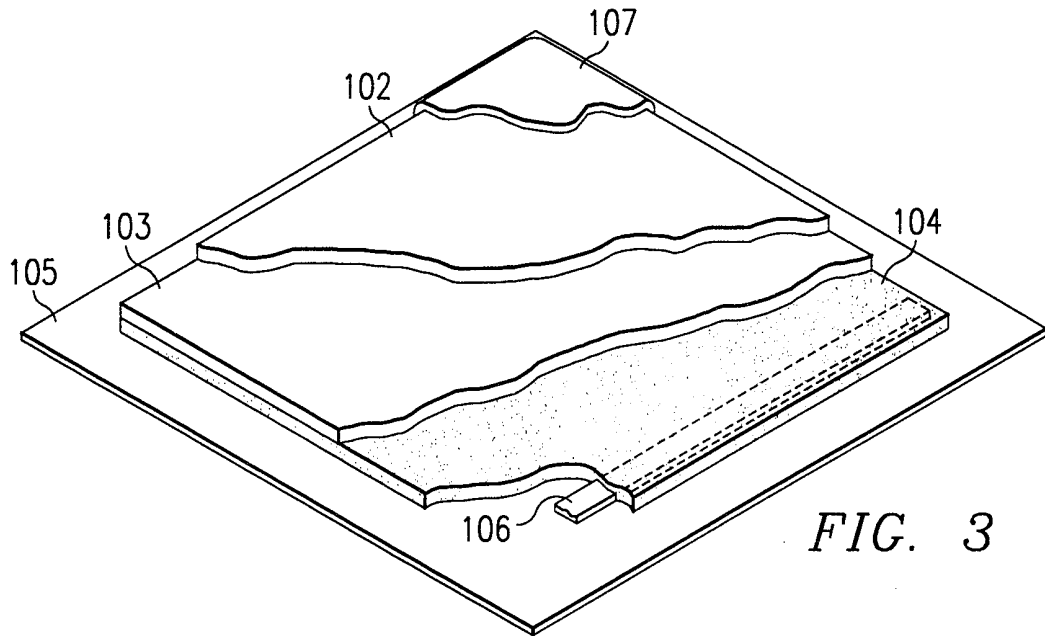



FIG. 5A



FIG. 5B

INTERNATIONAL SEARCH REPORT

International application No.
PCT/US99/12765

A. CLASSIFICATION OF SUBJECT MATTER IPC(6) :IPC(6): G06K9/00 US CL :382/124, 120, 121; 315/156, 169.3, 169.2, 246; According to International Patent Classification (IPC) or to both national classification and IPC		
B. FIELDS SEARCHED Minimum documentation searched (classification system followed by classification symbols) U.S. : 382/124, 120, 121; 315/156, 169.3, 169.2, 246;		
Documentation searched other than minimum documentation to the extent that such documents are included in the fields searched		
Electronic data base consulted during the international search (name of data base and, where practicable, search terms used) APS		
C. DOCUMENTS CONSIDERED TO BE RELEVANT		
Category*	Citation of document, with indication, where appropriate, of the relevant passages	Relevant to claim No.
Y	US 5,079,483 A (SATO) 07 JANUARY 1992 (07.01.92), col. 32 - 68.	1-17
Y	US 3,663,194 A (GREENSTEIN et al.) 16 MAY 1972 (16.05,72), col. 1, lines 30-70 .	1-17
Y	US 4,720,432 A (VANSLYKE et al.) 19 JANUARY 1988 (19.01.88), col. 2, lines 55-68. col. 3, lines 1-68.	1-17
<input type="checkbox"/> Further documents are listed in the continuation of Box C. <input type="checkbox"/> See patent family annex.		
A	document defining the general state of the art which is not considered to be of particular relevance	*T* later document published after the international filing date or priority date and not in conflict with the application but cited to understand the principle or theory underlying the invention
E	earlier document published on or after the international filing date	*X* document of particular relevance; the claimed invention cannot be considered novel or cannot be considered to involve an inventive step when the document is taken alone
L	document which may throw doubts on priority claim(s) or which is cited to establish the publication date of another citation or other special reason (as specified)	*Y* document of particular relevance; the claimed invention cannot be considered to involve an inventive step when the document is combined with one or more other such documents, such combination being obvious to a person skilled in the art
O	document referring to an oral disclosure, use, exhibition or other means	*&* document member of the same patent family
P	document published prior to the international filing date but later than the priority date claimed	
Date of the actual completion of the international search 12 AUGUST 1999		Date of mailing of the international search report 02 SEP 1999
Name and mailing address of the ISA/US Commissioner of Patents and Trademarks Box PCT Washington, D.C. 20231 Facsimile No. (703) 305-3230		Authorized officer SHEELA CHAWAN <i>Sheela Chawan</i> Telephone No. (703) 308-3900