

(19) World Intellectual Property Organization
International Bureau



(43) International Publication Date
23 July 2009 (23.07.2009)

PCT

(10) International Publication Number
WO 2009/090225 A1

- (51) International Patent Classification:
B65D 51/16 (2006.01) *B65D 77/06* (2006.01)
- (21) International Application Number:
PCT/EP2009/050444
- (22) International Filing Date: 15 January 2009 (15.01.2009)
- (25) Filing Language: English
- (26) Publication Language: English
- (30) Priority Data:
08100514.2 15 January 2008 (15.01.2008) EP
- (71) Applicant (for all designated States except US): **INBEV S.A.** [BE/BE]; Grand-Place 1, B-1000 Bruxelles (BE).
- (72) Inventors; and
- (75) Inventors/Applicants (for US only): **VALLES, Vanessa** [BE/BE]; Jagerstraat 42/9, B-3500 Hasselt (BE). **PEIRSMAN, Daniël** [BE/BE]; Eksterlaan 6, B-2880 Bornem (BE). **VANHOVE, Sarah** [BE/BE]; Strijdersstraat 10, B-3370 Boutersem (BE).
- (74) Agent: **GEVERS, François**; Gevers & Vander Haeghen, Holidaystraat 5, B-1831 Diegem (BE).

- (81) Designated States (unless otherwise indicated, for every kind of national protection available): AE, AG, AL, AM, AO, AT, AU, AZ, BA, BB, BG, BH, BR, BW, BY, BZ, CA, CH, CN, CO, CR, CU, CZ, DE, DK, DM, DO, DZ, EC, EE, EG, ES, FI, GB, GD, GE, GH, GM, GT, HN, HR, HU, ID, IL, IN, IS, JP, KE, KG, KM, KN, KP, KR, KZ, LA, LC, LK, LR, LS, LT, LU, LY, MA, MD, ME, MG, MK, MN, MW, MX, MY, MZ, NA, NG, NI, NO, NZ, OM, PG, PH, PL, PT, RO, RS, RU, SC, SD, SE, SG, SK, SL, SM, ST, SV, SY, TJ, TM, TN, TR, TT, TZ, UA, UG, US, UZ, VC, VN, ZA, ZM, ZW.
- (84) Designated States (unless otherwise indicated, for every kind of regional protection available): ARIPO (BW, GH, GM, KE, LS, MW, MZ, NA, SD, SL, SZ, TZ, UG, ZM, ZW), Eurasian (AM, AZ, BY, KG, KZ, MD, RU, TJ, TM), European (AT, BE, BG, CH, CY, CZ, DE, DK, EE, ES, FI, FR, GB, GR, HR, HU, IE, IS, IT, LT, LU, LV, MC, MK, MT, NL, NO, PL, PT, RO, SE, SI, SK, TR), OAPI (BF, BJ, CF, CG, CI, CM, GA, GN, GQ, GW, ML, MR, NE, SN, TD, TG).

Published:

- with international search report
- before the expiration of the time limit for amending the claims and to be republished in the event of receipt of amendments

(54) Title: ASSEMBLY OF A CONTAINER AND A CLOSURE

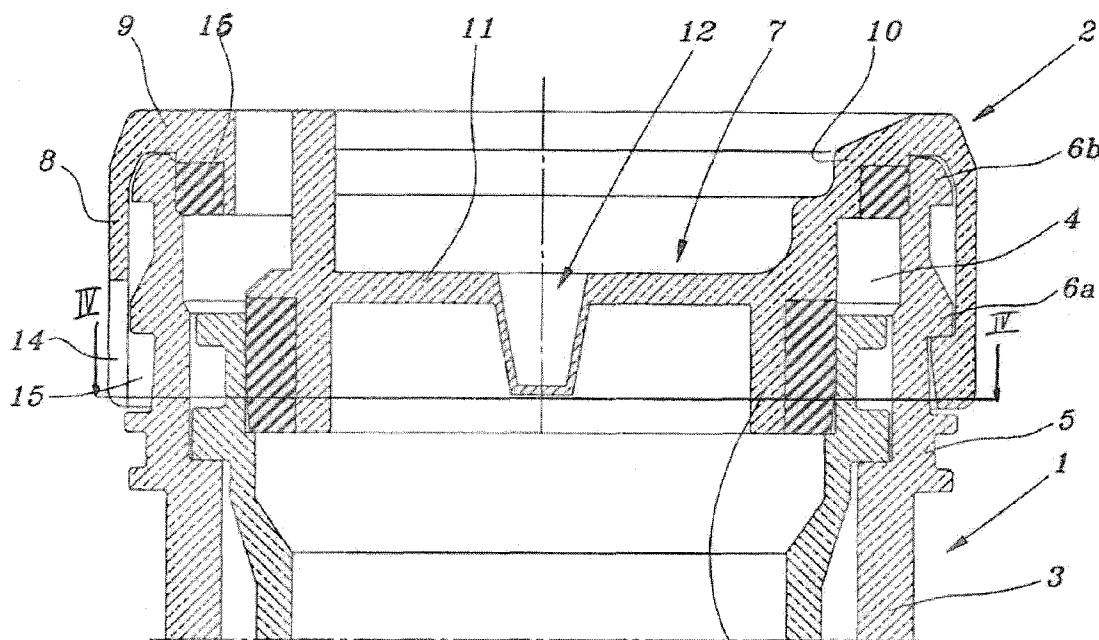

FIG. 1

(57) Abstract: An assembly of a container and a closure, the assembly comprising an overpressure relief system, characterized in that the system comprises a fixation between the closure (2) and a container (1), the fixation comprising two positions in between which the closure (2) is movable.

WO 2009/090225 A1

ASSEMBLY OF A CONTAINER AND A CLOSURE

Field of the Invention

5 The present invention generally relates to an assembly of a container and a closure for sealing an opening in said container, particularly to such an assembly comprising an overpressure relief system.

Background of the Invention

10

It is generally known that containers for storing carbonated beverages necessitate an overpressure relief system. Such an overpressure relief system has the aim to prevent uncontrolled burst of the container or closure or an uncontrolled ejection of a valve or closure fixed thereto. Existing overpressure relief systems included
15 containers having weakened spots in their body so as to allow a controlled burst in case of overpressure of the use of overpressure valves. With the increasing interest in home appliances, containers with weakened spots in their body have become undesirable, while valves are considered as expensive and as such also undesired. Accordingly, overpressure relief systems have been incorporated in the closure of
20 containers.

20

Overpressure release systems are described in the art. For example EP-A-1 614 636 and US 5,328,063 both disclose a closure comprising a mount piece that is snap fitted on a container and defining an outflow opening thereof. Centrally in the outflow
25 opening is provided a stem that is an integral part of the mount piece. The closure further comprises a closure cap fixed to the mount piece, the closure cap comprising a flexible diaphragm sealing an outlet of the container and having a free edge that engages the stem. When overpressure occurs in the container, the flexible diaphragm deforms and an opening is created between the stem and the free end of
30 the diaphragm, thereby allowing overpressure relief.

30

A drawback of the prior art closures incorporating an overpressure relief system is that the essentially comprise a flexible diaphragm, which clearly limits design options with respect to access control by example given piercing. Another drawback is that

said closures comprise different materials, in particular a rigid portion for the fixation of the closure to the mount piece of container and a flexible portion for allowing overpressure relief. Hence, the manufacturing and recycling of the known closures is relatively complicated and expensive.

5

Summary of the Invention

The present invention concerns an assembly of a container and a closure, the assembly comprising an overpressure relief system, characterized in that the system
10 comprises a fixation between the closure and a container, the fixation comprising two fixation positions in between which the closure is movable.

Said fixation preferably comprising a first fixation position wherein the closure seals the opening of the container.

15

Said fixation preferably comprising a second fixation position wherein the sealing between the closure and the container is disrupted, thereby allowing pressure relief.

According to a preferred embodiment of the assembly according the invention, the
20 fixation comprises a snap fit.

It is particularly preferred the container comprises a neck portion that is provided with at least two sets of outwardly extending protrusions, both sets being provided at a different level.

25

Further it is preferred that the closure comprises a base part and a skirt extending transversally with respect to the base, the skirt – that preferably is a continuous cylinder - comprising at least one set of inwardly directed protrusions configured to snap fit the closure behind one of the sets of protrusions on the containers neck
30 portion.

Description of the Invention

An assembly of a container and closure in accordance with the invention has the advantage that the overpressure relief system is situated at the level of fixation of the closure on the container. As such the area of the closure that usually plays a role in access control to the container is not involved in the pressure relief system and no special provisions are necessitated at this area, resulting in greater design flexibility than in the known closures provided with overpressure relief systems.

Another advantage is that the overpressure relief system incorporated in the assembly according to the present invention includes two fixation positions of the closure onto the container, whereby the closure is moved between both positions upon activation of the pressure relief system. Hence, the present assembly does not necessitate high flexible materials to allow pressure relief and the closure can be manufactured in one single material, thereby allowing cost reduction and facilitating recycling.

Brief Description of the Drawings

In order to better explain the characteristics of the invention, the following preferred embodiments of an assembly according to the invention is given as an example only without being limitative in any way, with reference to the accompanying drawings, in which:

Figure 1 represents a cross section of an assembly according to the present invention; Figure 2 represents a corresponding cross section of the assembly as figure 1, though in another fixation position of the closure on the container; Figure 3 represents a cross section corresponding to figure 1 for an alternative embodiment of the assembly according to the invention;

Figure 4 represents a cross-section of the closure according to line IV-IV in figure 1.

Detailed Description of Embodiment(s)

Figure 1 represents an assembly according to the present invention, the assembly comprising a container 1 and a closure 2 fixed thereon.

5 The container 1 is provided with a neck portion 3 defining an opening 4 in the container 1. In the represented embodiment, the neck portion 3 comprises a cylindrical wall part 5 whereon are provided at least two sets 6a and 6b of outwardly extending protrusions, both sets being provided at a different level of the neck portion 3.

10 The different protrusions of a single set 6a or 6b are preferably positioned in an annular configuration and on a same level of the neck portion 3 and can be mutually spaced-apart or can form a continuous annular rim.

The closure 2 comprises a base 7 and a skirt 8 extending transversally with respect
15 to the general plane of the base 7.

The base 7 is provided with a hub 9 having a peripheral edge extending into the skirt 8. At the inner edge of the hub 9 is provided a cylindrical wall 10 portion extending in a same direction as the skirt 8, which cylindrical wall portion 10 is fixed to a circular
20 disc 11. In the present embodiment, this disc comprises a wedged area 12, defining an access port to the opening 4 of the container 1.

Concentrically around the wedged area 12, a further cylindrical wall portion 13 is provided on said disc 11, the further wall portion 13 extending in a same sense as
25 the skirt 8 and having a diameter that is smaller than the diameter of the disc 11.

Turning now to the skirt 8, it is noted that the skirt comprises several spaced-apart members 14 extending transversally with respect to the base 7, these members 14 being provided with an inwardly directed protrusion 15 at their free end. These
30 protrusions 15 together form a set of protrusions 15 configured to cooperate in a snap fit relation with each of both sets of protrusions 6a and 6b on the neck portion 3 of the container 1.

In an assembled state, the closure 2 is provided onto the containers neck portion 3, such that the set of protrusions 15 of the closure 2 is snap fitted behind the set of protrusions 6a on the neck portion 3, situated closest to the containers body. In this fixation position, the hub 9 closely fits to the free edge of the neck portion 3, while a
5 sealing member 16 provided between the hub 9 and said free edge ensures that the opening 4 is properly sealed by the closure 2.

According to the invention the assembly of container 1 and closure 2 comprises an overpressure relief system comprising a fixation between the closure 2 and the
10 container 1, said fixation comprising two positions in between which the closure 2 is movable.

In the represented embodiment, the overpressure relief system comprises both sets of protrusions 6a and 6b of the neck portion 3 as well as the skirt 8 and the
15 corresponding set of protrusions 15.

In the above configuration of the assembly according to the invention, a first fixation position is the one wherein the set of protrusions 15 located on the skirt 8 are snap fitted (i.e. clamped) behind the set of protrusions 6a located closest to the containers
20 body and wherein the closure 2 seals said opening 4 of the container 1.

A second fixation position is represented in figure 2 and is defined as the position wherein the set of protrusions 15 of the skirt 8 are snap fitted behind the set of protrusions 6b located distant from the containers body. In this second fixation
25 position, the sealing of the opening 4 by the closure 2 is disrupted and that as such the space confined by the container 1 is in contact with the environment, thereby allowing overpressure relief.

Upon positioning the closure 2 in the first (sealing) fixation position and an
30 overpressure arises in the container, the overpressure will force the closure 2 upward into the second fixation position, wherein the overpressure is released, without the closure being loosened from the container. As such a controlled system is obtained to handle the safety issue of overpressure occurring in the container 1.

Appropriate materials for both the container and the closure or at least the elements constituting the overpressure relief system are stainless steel or synthetic materials such as for example polyesters or polyolefins.

5 In a preferred embodiment of the closure and as represented in figure 4, the members 14 or at least the protrusions 15 have a varying width. More particularly, the protrusions 15a located at one side of the closure have a width A, while the protrusions 15c at the opposite side of the closure have a width C, the protrusions 15b positioned in between having a width B, whereby $A < B < C$. The closure can
10 hereby be provided with six members 14 and protrusions 15a, 15b and 15c, wherein two adjacent protrusions 15a have a width A, the two protrusions 15c located opposite said first protrusions have a width C and the intermediate protrusions 15b have a width B.

15 In this embodiment, at overpressure in the container, the fixation shift of the closure at overpressure will preferentially occur at the protrusions 15a with the smallest width A, such that the closure actually tilts in relation to the container. Equally, in this embodiment the sealing of the closure on the container is only disrupted over a section of the containers neck.

20 Figure 3 represents an alternative embodiment, wherein the skirt 8 comprises a continuous cylinder, whereon the set of protrusions 15 is provided. In this embodiment, the different protrusions can either be distinct spaced-apart protrusions or can form a continuous ring.

25 In case the protrusions 15 form such a continuous ring and in the case the protrusion 6b located distant from the container 1 form a continuous rim, it is preferred that in either the ring or the rim or in both are provided some lateral grooves (not shown) that ensure contact between the space confined by the container and the
30 environment when the closure 2 is positioned in the second fixation position (i.e. the position allowing overpressure relief).

Configuring the skirt 8 as a continuous cylinder has the additional advantage that this skirt can be made very rigid, thereby allowing precise control of the force needed to move the closure from the first fixation position into the second fixation position.

5 In accordance with the above described embodiments, the neck portion 3 comprises at least two sets of protrusions 6a and 6b, while the closure is provided with at least one set of protrusions 15. In accordance with further embodiments the overpressure relief system can also comprise at least two sets of protrusions on the closure 2, and at least one set of protrusions on the neck portion 3, wherein during movement of the
10 closure 2 from a first fixation position to a second fixation position, the same set of protrusions on the neck portion 3 disengages the first set of protrusions of the closure 2 and subsequently engages the second set of protrusions of said closure 2.

It is noted that the above described overpressure relief system is especially suitable
15 as a safety feature preventing uncontrolled damage to the closure or the container. For releasing gradually increasing overpressure, a reversible pressure release mechanism can be provided by designing the closure, the neck portion of the container or the sealing member such that the sealing between these parts will be partially disrupted once a threshold pressure attained in the container, thereby
20 allowing pressure release. Once the pressure is sufficiently released, the sealing reengages automatically.

The above described assemblies according the invention are particularly suited for
25 containers designed to contain carbonated beverages, such as for example beer.

The present invention is particularly suitable for containers of the type generally known as bag-in-containers. Bag-in-containers, also referred to as bag-in-bottles or bag-in-boxes depending on the geometry of the outer vessel, all terms considered herein as being comprised within the meaning of the term bag-in-container, are a
30 family of liquid dispensing packaging consisting of an outer container comprising an opening to the atmosphere --the mouth-- and which contains a collapsable inner bag joined to said container and opening to the atmosphere at the region of said mouth. The system must comprise at least one vent fluidly connecting the atmosphere to the region between the inner bag and the outer container in order to control the pressure

in said region to squeeze the inner bag and thus dispense the liquid contained therein.

5 Traditionally, bag-in-containers were --and still are-- produced by independently producing an inner bag provided with a specific neck closure assembly and a structural container (usually in the form of a bottle). The bag is inserted into the fully formed bottle opening and fixed thereto by means of the neck closure assembly, which comprises one opening to the interior of the bag and vents fluidly connecting the space between bag and bottle to the atmosphere; examples of such
10 constructions can be found inter alia in US-A-3484011, US-A-3450254, US-A-4,330,066, and US-A-4892230.

In case the bag-in-box container is designed to receive a top chime, it is preferred to provide the skirt 8 of the closure 2 with a guided profile allowing an automated
15 assembly of the chime over the closure and on the container. As represented in figure 4, such guided profile can for example be designed such as to comprise several longitudinally extending edges 17 provided at the outer surface of the closure skirt 8.

20 The present invention is by no means limited to the embodiments described above and represented in the accompanying figures; on the contrary, such an assembly of a container and a closure comprising an overpressure relief system can be made in various executions while still remaining within the scope of the invention.

CLAIMS

1. An assembly of a container and a closure, the assembly comprising an overpressure relief system, characterized in that the system comprises a fixation between the closure (2) and a container (1), the fixation comprising two fixation positions in between which the closure (2) is movable.
5
2. The assembly according to claim 1, characterized in that said fixation comprises a first fixation position wherein the closure (2) seals the opening of the container (1).
10
3. The assembly according to claim 2, characterized in that said fixation comprises a second fixation position wherein the sealing between the closure (2) and the container (1) is disrupted, thereby allowing pressure relief.
15
4. The assembly according to any of claims 1 to 3, characterized in that the fixation comprises a snap fit.
5. The assembly according to any of claims 1 to 4, characterized in that the container comprises a neck portion (3) that is provided with at least two sets of outwardly extending protrusions (6a, 6b), both sets being provided at a different level.
20
6. The assembly according to claim 5, characterized in that the closure comprises a base part and a skirt (8) extending transversally with respect to the base (7), the skirt (8) comprising at least one set of inwardly directed protrusions (15) configured to snap fit the closure (2) behind one of the sets of protrusions (6a, 6b) on the containers neck portion (3).
25
7. The assembly according to any of the preceding claims, characterized in that the closure (2) comprises a skirt (8) comprising a continuous cylinder, whereon a set of protrusions (15) is provided configured to snap fit the closure (2) behind one of the sets of protrusions (6a, 6b) on the containers neck portion (3).
30

- 5 8. The assembly according to claim 6, characterized in that the skirt (8) of the closure (2) comprises several spaced-apart members (14) extending transversally with respect to the base (7) of the closure (2), these members (14) being provided with an inwardly directed protrusion (15).
- 10 9. The assembly according to claim 8, characterized in that the protrusions (15) located at one side of the closure have a width A, the protrusions (15) located at the opposite side of the closure have a width C, whereby $A < C$.
- 15 10. The assembly according to claim 8, characterized in that the protrusions (15) located at one side of the closure have a width A, the protrusions (15) located at the opposite side of the closure have a width C and the intermediate protrusions (15) have a width B, whereby $A < B < C$.
- 20 11. A closure comprising a base part (7) and a skirt (8) extending transversally with respect to the base (7), the skirt (8) comprising several spaced-apart members (14) extending transversally with respect to the base (7) of the closure (2), these members (14) being provided with an inwardly directed protrusion (15), characterized in that the protrusions (15) located at one side of the closure have a width A, the protrusions (15) located at the opposite side of the closure have a width C whereby $A < C$.
- 25 12. The closure according to claim 11, characterized in that between between the protrusions with width A and the protrusions with width C, protrusions are provided having a width B, whereby $A < B < C$.

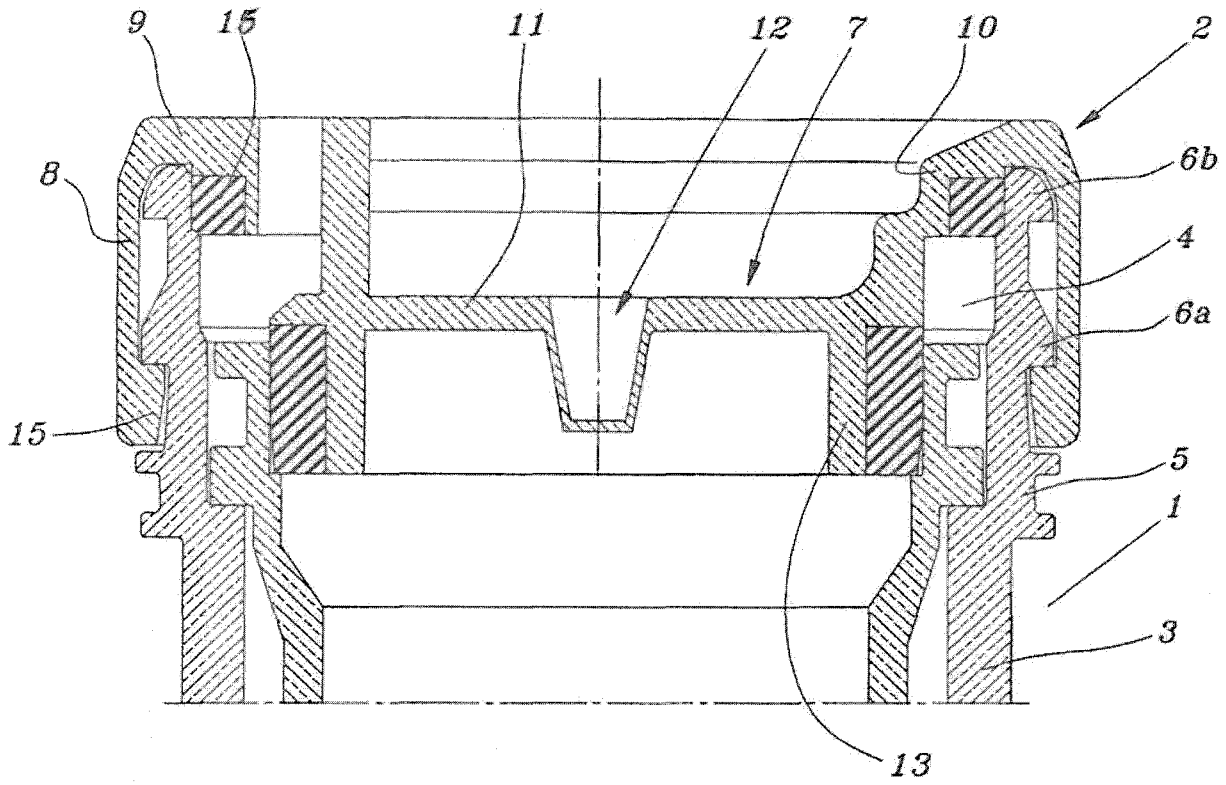

FIG. 3

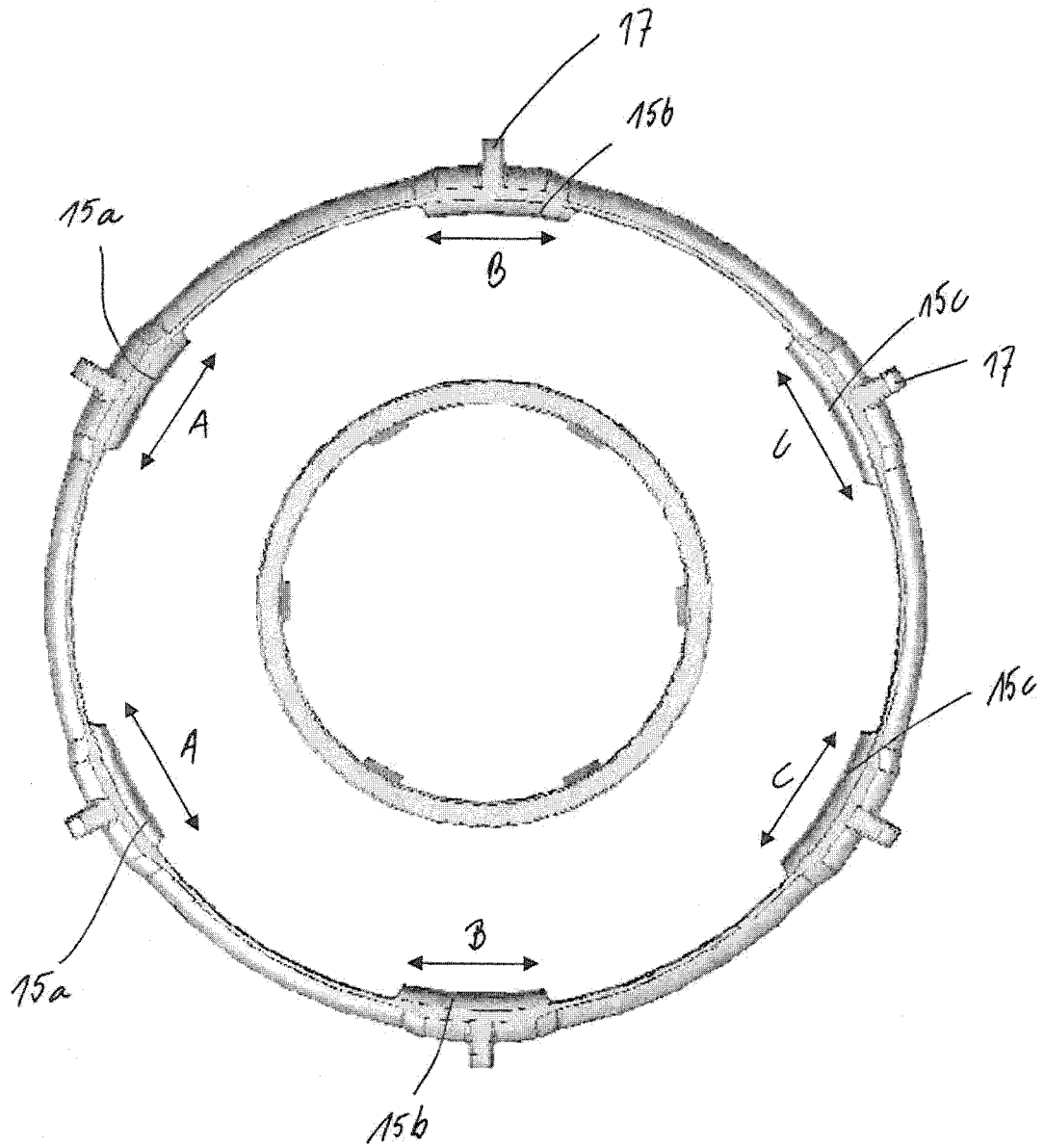

FIG. 4

INTERNATIONAL SEARCH REPORT

International application No

PCT/EP2009/050444

A. CLASSIFICATION OF SUBJECT MATTER
 INV. B65D51/16 B65D77/06

According to International Patent Classification (IPC) or to both national classification and IPC

B. FIELDS SEARCHED

Minimum documentation searched (classification system followed by classification symbols)
 B65D

Documentation searched other than minimum documentation to the extent that such documents are included in the fields searched

Electronic data base consulted during the international search (name of data base and, where practical, search terms used)

EPO-Internal

C. DOCUMENTS CONSIDERED TO BE RELEVANT

Category*	Citation of document, with indication, where appropriate, of the relevant passages	Relevant to claim No.
X	US 2 467 979 A (KRUEGER FRANK W) 19 April 1949 (1949-04-19) the whole document	1-7
X	GB 1 545 293 A (DEMATEX DEV & INVEST) 10 May 1979 (1979-05-10)	1-7
Y	page 2, line 1 - line 19; figures 1,2	8-10
X	EP 1 138 609 A (L & M SERVICES BV [NL]) 4 October 2001 (2001-10-04) paragraph [0022] - paragraph [0026]; figures 1,2B	1-5
	----- -/--	

Further documents are listed in the continuation of Box C.

See patent family annex.

* Special categories of cited documents :

"A" document defining the general state of the art which is not considered to be of particular relevance

"E" earlier document but published on or after the international filing date

"L" document which may throw doubts on priority claim(s) or which is cited to establish the publication date of another citation or other special reason (as specified)

"O" document referring to an oral disclosure, use, exhibition or other means

"P" document published prior to the international filing date but later than the priority date claimed

"T" later document published after the international filing date or priority date and not in conflict with the application but cited to understand the principle or theory underlying the invention

"X" document of particular relevance; the claimed invention cannot be considered novel or cannot be considered to involve an inventive step when the document is taken alone

"Y" document of particular relevance; the claimed invention cannot be considered to involve an inventive step when the document is combined with one or more other such documents, such combination being obvious to a person skilled in the art.

"&" document member of the same patent family

Date of the actual completion of the international search

28 May 2009

Date of mailing of the international search report

05/06/2009

Name and mailing address of the ISA/

European Patent Office, P.B. 5818 Patentlaan 2
 NL - 2280 HV Rijswijk
 Tel. (+31-70) 340-2040,
 Fax: (+31-70) 340-3016

Authorized officer

Appelt, Lothar

INTERNATIONAL SEARCH REPORT

International application No
PCT/EP2009/050444

C(Continuation). DOCUMENTS CONSIDERED TO BE RELEVANT

Category*	Citation of document, with indication, where appropriate, of the relevant passages	Relevant to claim No.
X	US 6 158 604 A (LARGUIA SR CONSTANCIO [AR] ET AL) 12 December 2000 (2000-12-12) column 6, line 4 - line 64 column 9, line 66 - column 10, line 46 column 23, line 30 - column 24, line 8 figures 1-16 -----	1-4
X	WO 97/43188 A (CROWN CORK AG [CH]; BOESL UDO [DE]; DREYER LINO [FR]) 20 November 1997 (1997-11-20) page 2, paragraph 4 - page 3, paragraph 1 page 10, paragraph 2 - page 11, paragraph 2 figures 1-3 -----	1-4,8,9, 11
X	DE 969 306 C (KARL RETTMEYER) 22 May 1958 (1958-05-22)	11,12
Y	page 2, line 68 - line 74; figures 1-5 -----	8-10
X	DE 814 258 C (HOFFELNER KARL) 20 September 1951 (1951-09-20) figures 5,6 -----	11
A	US 5 934 500 A (COGGER JOHN [US] ET AL) 10 August 1999 (1999-08-10) figure 2 -----	1-12

INTERNATIONAL SEARCH REPORT

International application No.
PCT/EP2009/050444

Box No. II Observations where certain claims were found unsearchable (Continuation of item 2 of first sheet)

This international search report has not been established in respect of certain claims under Article 17(2)(a) for the following reasons:

1. Claims Nos.:
because they relate to subject matter not required to be searched by this Authority, namely:

2. Claims Nos.:
because they relate to parts of the international application that do not comply with the prescribed requirements to such an extent that no meaningful international search can be carried out, specifically:

3. Claims Nos.:
because they are dependent claims and are not drafted in accordance with the second and third sentences of Rule 6.4(a).

Box No. III Observations where unity of invention is lacking (Continuation of item 3 of first sheet)

This International Searching Authority found multiple inventions in this international application, as follows:

see additional sheet

1. As all required additional search fees were timely paid by the applicant, this international search report covers allsearchable claims.

2. As all searchable claims could be searched without effort justifying an additional fees, this Authority did not invite payment of additional fees.

3. As only some of the required additional search fees were timely paid by the applicant, this international search report covers only those claims for which fees were paid, specifically claims Nos.:

4. No required additional search fees were timely paid by the applicant. Consequently, this international search report is restricted to the invention first mentioned in the claims; it is covered by claims Nos.:

Remark on Protest

- The additional search fees were accompanied by the applicant's protest and, where applicable, the payment of a protest fee.
- The additional search fees were accompanied by the applicant's protest but the applicable protest fee was not paid within the time limit specified in the invitation.
- No protest accompanied the payment of additional search fees.

FURTHER INFORMATION CONTINUED FROM PCT/ISA/ 210

This International Searching Authority found multiple (groups of) inventions in this international application, as follows:

1. claims: 1-8

Assembly of a container and a closure having an overpressure relief system wherein the closure can assume two fixation positions on the container

2. claims: 9-12

Closure having a base and a skirt wherein the skirt comprises spaced-apart members extending transversally with respect to the base and being provided with protrusions of a different width; the closure is for use with an overpressure relief system or not

INTERNATIONAL SEARCH REPORT

Information on patent family members

International application No

PCT/EP2009/050444

Patent document cited in search report	Publication date	Patent family member(s)	Publication date
US 2467979	A	19-04-1949	NONE
GB 1545293	A	10-05-1979	NONE
EP 1138609	A	04-10-2001	AU 6382401 A 08-10-2001 CA 2404952 A1 04-10-2001 WO 0172597 A1 04-10-2001 HU 0300319 A2 28-06-2003
US 6158604	A	12-12-2000	WO 9821111 A1 22-05-1998 US 5960972 A 05-10-1999
WO 9743188	A	20-11-1997	AT 190029 T 15-03-2000 AU 2501997 A 05-12-1997 CA 2250886 A1 20-11-1997 DE 59701183 D1 06-04-2000 EP 0904237 A1 31-03-1999 ID 18171 A 12-03-1998
DE 969306	C	22-05-1958	NONE
DE 814258	C	20-09-1951	NONE
US 5934500	A	10-08-1999	NONE