

[72] Inventor **Anastas Boornard**
Barrington, N.J.
 [21] Appl. No. **757,951**
 [22] Filed **Sept. 6, 1968**
 [45] Patented **July 20, 1971**
 [73] Assignee **RCA Corporation**

3,368,169 2/1968 Carter et al. 333/73 W
 3,400,343 9/1968 Carter 33/24.2 X

OTHER REFERENCES

De Grasse, R. W., "Low-Loss Gyromagnetic Coupling Through Single Crystal Garnets," J. OF APPLIED PHYSICS SUPPLEMENT to Vol. 30 04, 4-1959 pp. 155S- 156S

Primary Examiner—Herman Karl Saalbach
Assistant Examiner—Wm. H. Punter
Attorney—Edward J. Norton

[54] GYROMAGNETIC NOTCH FILTER
6 Claims, 2 Drawing Figs.

[52] U.S. Cl. 333/73 S,
 333/24.2, 333/84 M
 [51] Int. Cl. H03h 13/00,
 H01p 5/04, H01p 1/32
 [50] Field of Search 333/1.1, 73
 S, 84 M, 24.2, 73, 84, 73 C, 17, 73 W

[56] References Cited
UNITED STATES PATENTS

3,013,229 12/1961 De Grasse 333/73 W
 3,016,495 1/1962 Tien 333/1.1 X
 3,353,119 11/1967 Honig et al. 333/24.2 X

ABSTRACT: A notch filter is disclosed which includes a pair of conductors extending transversely of each other in a cross-like configuration, the conductors being insulated from each other. A ball of ferri- or ferromagnetic material is positioned between the two conductors where they cross. A magnetic field is applied to the ball and, by variation of the field, a band of waves that is applied to one end of one of the conductors does not arrive at the other end of said conductor but is dissipated in resistors connected to the ends of the other conductor.

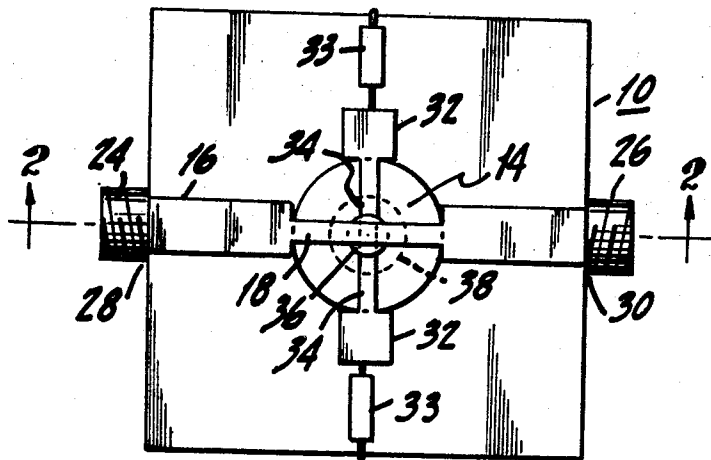

Fig. 1.

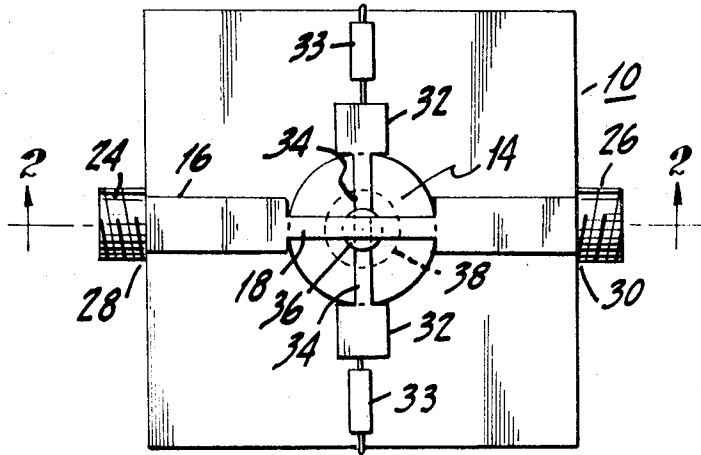
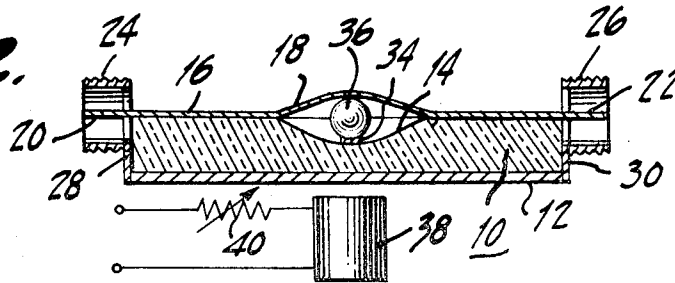

Fig. 2.



INVENTOR
Anastas Boornard

BY *Simon Yaffee*
ATTORNEY

GYROMAGNETIC NOTCH FILTER

Sharply tunable notch or rejection filters in the MegaHertz or gigaHertz (a thousand MegaHertz) ranges are useful in separating undesired waves from signal waves, as, for example, in antijamming devices.

It is an object of this invention to provide an improved notch or rejection filter in the MegaHertz or gigaHertz range.

A notch filter is disclosed which includes a pair of conductors extending transversely of each other in a crosslike configuration, the conductors being insulated from each other. A mass of ferri- or ferro-material is positioned adjacent the crossing of the two conductors. Input waves are applied between one end of one conductor and a baseplate, and output waves are taken from between the other end of the said one conductor and the baseplate. At least one end of the other conductor is connected to the baseplate by way of a terminating resistor. The one conductor is coupled to the other conductor only at a frequency depending on the strength of a magnetic field which is applied to the mass of ferri- or ferro-magnetic material, whereby waves of the coupled frequency are dissipated in the resistor and do not reach the output end of the one conductor.

DESCRIPTION

The invention may be better understood upon reading the following description in connection with the accompanying drawing in which:

FIG. 1 is a plan view of a notch filter according to an embodiment of this invention, and

FIG. 2 is a section of FIG. 1 on line 2-2 thereof.

A block 10 of low loss insulating material has a conducting, nonmagnetic coating 12 on the lower side thereof as viewed in FIG. 2, and the center of the opposite side of block 10 is dished in as indicated by the reference character 14. A strip of nonmagnetic conducting material 16 extends across the top of the block 10. The center portion 18 of the strip 16 is narrowed as shown in FIG. 1 and is bowed upwards as shown in FIG. 2. The ends of the strips 16 are connected to respective inner conductors 20 and 22 of concentric connectors 24 and 26. The outer conductors of the connectors 24 and 26 are connected to the baseplate 12 by respective conductors 28 and 30.

A second nonmagnetic conductor 32 extends across the top of the block 10 in a direction transverse to the direction of the strip 16. The central portion 34 of the conductive strip 32 is necked down, and the necked down portion 34 is bowed downward into the dished portion 14 of the block 10, whereby the portion 18 of the conductive strip 16 and the portion 34 of the conductive strip 32 are spaced from, and therefore insulated from, each other. The opposite ends of the conductor 32 are connected by respective terminating resistors 33 to the baseplate 12.

A mass 36 of ferri- or ferro-magnetic material which may be in the shape of a ball, is positioned between the portions 18 and 34 of the conductors 16 and 32. The spacing between the portions 18 and 34 and the size of the ball 36 may be such that the ball 36 touches neither of the conductors 18 or 34, wherein the ball 36 may be held by suitable means, i.e. insulation, between the portions 18 and 34 but out of contact with either portion or both. A magnet 38 is so positioned that its lines of force penetrate the ball 36. The magnetic field of the magnet 38 may be varied by varying the resistance of a resistor 40 connected between the magnet 38 and the source of supply therefore, not shown. If desired, a permanent magnet, not shown may be substituted for the electromagnet 38.

In the described notched filter, in the absence of the ball 36, the strips 16 and 18 are not coupled and a wave applied to the connection device 24 or 26 arrives at the connection devices 26 or 24 substantially unchanged. When the ball 36 is provided as shown and the magnetic field produced by the magnet 38 is properly adjusted, a wave of a predetermined

frequency appearing in the conductor 18 is coupled to the conductor 34 and is dissipated in the terminating resistors 33, 33 whereby the wave of the predetermined frequency applied to one of the conductors 24 and 26 does not arrive at the other connector 26 and 24. It is thought that the magnetic field in the ball 36 rotates in such a manner as to describe one or more conical surfaces and that the frequency of rotation depends on the strength of the magnetic field. The two conductor portions 18 and 34 are coupled due to this rotation of the magnetic field in the ball 36 and the frequency of the rejected or absorbed wave depends on the rotation frequency.

The ball 36 may be of a ferri-magnetic material known as YIG (yttrium iron garnet) however it may be made of any good ferri-magnetic material. Certain ferro-magnetic materials are also useful as a material for the ball 36. The size of the ball, while not critical may be from 1/200 to one-tenth of an inch in diameter. Within limits, the bigger the ball 36, the greater the width of the notch or of the band of rejected waves. The strips 16 and 32 may be about a thousandth of an inch thick and the necked down portion thereof 18 and 34 may be a little smaller in width than the diameter of the ball 36. The strips 16 and 32 are necked down at 18 and 34 to increase the radio frequency field in the vicinity of the necked down portions. The necked down portion 18 and 34 may be formed of wire conductively connected to the remainder of the respective conductive strips 16 and 32. The wider portions of the strips 16 and 32 while not critical may be about one-fifth of an inch wide. Also within limits, the narrower the narrow portions 18 and 34 of the strips 16 and 32, and the greater their separation, the narrower the rejection band of the described filter. Therefore, by choice of the size of the ball 36 and of the width of the strip portions 18 and 34, the width of the rejection band of the filter may be predetermined.

A notch filter may be provided by providing two insulating blocks, one having a hole therethrough. A baseplate, such as 12 of FIG. 2 may be applied to one side of the imperforate block and a conductor such as 32, 34, 32 may be applied to the other side of the imperforate block. The other block may be so laid on the imperforate block that the strip 34 runs across the hole in the other block. A ball such as the ball 36 may be positioned in the hole and the other strip such as the strip 16, 18, 16 may extend across the exposed surface of the other block so that it extends across the hole in the other block and transversely of the first-mentioned strip. Such a notch filter operates similarly to the notch filter of FIGS. 1 and 2.

What I claim is:

1. A notch filter comprising:

a base conductor,
a pair of conductors spaced from and at one side of said base conductor, said pair of conductors extending transversely of each other,
said pair of conductors being insulated from each other,
a mass of insulating magnetic material positioned at the crossing of said pair of conductors,
means to apply a wave to be filtered to one end of one of said pair of conductors,
means to take a filtered wave from the other end of said one conductor, and
a resistor connected between one end of said other conductor and said base conductor.

2. The invention as expressed in claim 1 in which means are provided to produce a magnetic field which penetrates said magnetic mass.

3. The invention as expressed in claim 1 in which said mass is between said two conductors at their crossing.

4. A notch filter comprising a base conductor,
a pair of conductors at one side of said base conductor, said conductors extending transversely of each other and being insulated from each other,
a mass of insulating magnetic material at the crossing of said pair of conductors,
means to apply a wave to be filtered to one end of one of said pair of conductors,

3

4

means to take a filtered wave from the other end of said one conductor,
means to connect the ends of said other of said pair of conductors through a respective resistor to said base conductor, and
means to apply a magnetic field to said mass of insulating material.

5. The invention as expressed in claim 4 in which said base conductor is applied to one side of an insulator and in which at least a portion of each of said pair of conductors is applied to the other side of said insulator.
5 6. The invention as expressed in claim 4 in which said mass is a of yttrium iron garnet material.

10

15

20

25

30

35

40

45

50

55

60

65

70

75