



- (51) International Patent Classification:  
A61B 1/32 (2006.01)
- (21) International Application Number:  
PCT/US2012/058074
- (22) International Filing Date:  
28 September 2012 (28.09.2012)
- (25) Filing Language: English
- (26) Publication Language: English
- (30) Priority Data:
 

61/541,975	30 September 2011 (30.09.2011)	US
61/541,624	30 September 2011 (30.09.2011)	US
61/541,980	30 September 2011 (30.09.2011)	US
61/541,978	30 September 2011 (30.09.2011)	US
- (71) Applicant (for all designated States except US):  
**BIOVENTRIX, INC.** [US/US]; 12647 Alcosta Blvd., Suite 400, San Ramon, California 94583 (US).
- (72) Inventors; and
- (71) Applicants (for US only): **VAN BLADEL, Kevin** [US/US]; Livermore, California (US). **ANNEST, Lon** [US/US]; New York, New York (US). **STIGGELBOUT, John** [US/US]; Sausalito, California (US). **ARCIA, Rovil** [US/US]; Fremont, California (US).
- (74) Agents: **WEIGHT, Clark, F.** et al.; Eighth Floor, Two Embarcadero Center, San Francisco, CA 94111 (US).

- (81) Designated States (unless otherwise indicated, for every kind of national protection available): AE, AG, AL, AM, AO, AT, AU, AZ, BA, BB, BG, BH, BN, BR, BW, BY, BZ, CA, CH, CL, CN, CO, CR, CU, CZ, DE, DK, DM, DO, DZ, EC, EE, EG, ES, FI, GB, GD, GE, GH, GM, GT, HN, HR, HU, ID, IL, IN, IS, JP, KE, KG, KM, KN, KP, KR, KZ, LA, LC, LK, LR, LS, LT, LU, LY, MA, MD, ME, MG, MK, MN, MW, MX, MY, MZ, NA, NG, NI, NO, NZ, OM, PA, PE, PG, PH, PL, PT, QA, RO, RS, RU, RW, SC, SD, SE, SG, SK, SL, SM, ST, SV, SY, TH, TJ, TM, TN, TR, TT, TZ, UA, UG, US, UZ, VC, VN, ZA, ZM, ZW.
- (84) Designated States (unless otherwise indicated, for every kind of regional protection available): ARIPO (BW, GH, GM, KE, LR, LS, MW, MZ, NA, RW, SD, SL, SZ, TZ, UG, ZM, ZW), Eurasian (AM, AZ, BY, KG, KZ, RU, TJ, TM), European (AL, AT, BE, BG, CH, CY, CZ, DE, DK, EE, ES, FI, FR, GB, GR, HR, HU, IE, IS, IT, LT, LU, LV, MC, MK, MT, NL, NO, PL, PT, RO, RS, SE, SI, SK, SM, TR), OAPI (BF, BJ, CF, CG, CI, CM, GA, GN, GQ, GW, ML, MR, NE, SN, TD, TG).

**Published:**

- with international search report (Art. 21(3))
- before the expiration of the time limit for amending the claims and to be republished in the event of receipt of amendments (Rule 48.2(h))

(54) Title: REMOTE PERICARDIAL HEMOSTASIS FOR VENTRICULAR ACCESS AND RECONSTRUCTION OR OTHER ORGAN THERAPIES

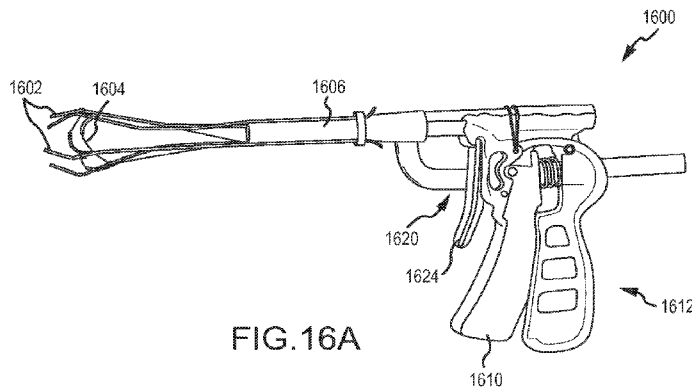

(57) Abstract: Embodiments described herein provide devices, systems, and methods that reduce the distance between two locations in tissue, often for treatment of congestive heart failure. For example, an anchor of an implant system may, when the implant system is fully deployed, reside within the right ventricle in engagement with the ventricular septum. The anchor may be deployed into the heart through a working lumen of a minimally invasive access tool. The minimally invasive access tool may have a plurality of grippers near a distal end of the working lumen. The grippers may engage epicardial tissue of the heart and may be moved radially inwardly relative so as to provide stabilization of the epicardial tissue and/or hemostasis near an access site where the anchor is inserted through the epicardium. The minimally invasive access tool may minimize blood loss from the access site and improve anchor implant processes.

WO 2013/049682 A1

## REMOTE PERICARDIAL HEMOSTASIS FOR VENTRICULAR ACCESS AND RECONSTRUCTION OR OTHER ORGAN THERAPIES

### CROSS-REFERENCES TO RELATED APPLICATIONS

This application is related to and claims the benefit of U.S. Provisional Patent Application No. 5 61/541,975 entitled "Remote Pericardial Hemostasis for Ventricular Access and Reconstruction or Other Organ Therapies," filed September 30, 2011. This application is also related to and claims the benefit of U.S. Provisional Patent Application No. 61/541,624 entitled "Trans-Catheter Ventricular Reconstruction Structures, Methods, and Systems for Treatment of Congestive Heart Failure and Other Conditions," filed September 30, 2011; U.S. Provisional 10 Patent Application No. 61/541,980 entitled "Over-The-Wire Cardiac Implant Delivery System for Treatment of CHF and Other Conditions," filed September 30, 2011; and U.S. Provisional Patent Application No. 61/541,978 entitled "Cardiac Implant Migration Inhibiting Systems," filed September 30, 2011; the full disclosures of which are incorporated herein by reference in their entirety.

15 The subject matter of this application is also related to that of US Patent Publication No. US2009/0093670, as published on April 9, 2009 and entitled "Treating Dysfunctional Cardiac Tissue;" and to that of US Patent Publication No. US2010/0016655, as published on January 21, 2010 and entitled "Cardiac Anchor Structures, Methods, and Systems for treatment of Congestive Heart Failure and Other Conditions;" the full disclosures of which are incorporated 20 herein by reference in their entirety.

### BACKGROUND OF THE INVENTION

The present invention is related to improved medical devices, systems, and methods, with many embodiments being particularly useful for reducing the distance between two points in tissue in a minimally or less invasive manner. Specific reference is made to the treatment of a failing heart, 25 particularly the alleviation of congestive heart failure and other progressive heart diseases. The provided devices, systems, and methods will often be used so as to resize or alter the geometry of a ventricle in a failing heart, such as by reducing its radius of curvature through the process of excluding a portion of the circumference from contact with blood, and thereby reduce wall stress on the heart and improve the heart's pumping performance. Although specific reference is made

to the treatment of congestive heart failure, embodiments of the present invention can also be used in other applications in which tissue geometry is altered.

Exemplary embodiments described herein provide implants and methods for alleviating congestive heart failure and other progressive diseases of the heart. Congestive heart failure  
5 may, for example, be treated using one or more implants which are selectively positioned relative to a first wall of the heart (typically an interventricular septum), and another wall of the heart so as to exclude scar tissue and limit a cross sectional area, or distance across a ventricle.

Functional deterioration of the heart tissues may be inhibited by decreasing a size of the heart chamber and/or approximating tissues so that stress on the tissues is limited. Implant locations  
10 and overall chamber remodeling achieved by placement of a series of implants may be determined so as to provide a beneficial volumetric decrease and chamber shape.

Congestive heart failure (sometimes referred to as "CHF" or "heart failure") is a condition in which the heart does not pump enough blood to the body's other organs. Congestive heart failure may in some cases result from narrowing of the arteries that supply blood to the heart muscle,  
15 high blood pressure, heart valve dysfunction due to degenerative processes or other causes, cardiomyopathy (a primary disease of the heart muscle itself), congenital heart defects, infections of the heart tissues, and the like. However, in many cases congestive heart failure may be triggered by a heart attack or myocardial infarction. Heart attacks can cause scar tissue that  
interferes with the heart muscle's healthy function, and that scar tissue can progressively replace  
20 more and more of the contractile heart tissue. More specifically, the presence of the scar may lead to a compensatory neuro-hormonal response by the remaining, non-infarcted myocardium leading to progressive dysfunction and worsening failure.

People with heart failure may have difficulty exerting themselves, often becoming short of breath, tired, and the like. As blood flow out of the heart decreases, pressure within the heart  
25 increases. Not only does overall body fluid volume increase, but higher intracardiac pressure inhibits blood return to the heart through the vascular system. The increased overall volume and higher intracardiac pressures result in congestion in the tissues. Edema or swelling may occur in the legs and ankles, as well as other parts of the body. Fluid may also collect in the lungs, interfering with breathing (especially when lying down). Congestive heart failure may also be  
30 associated with a decrease in the ability of the kidneys to remove sodium and water, and the fluid buildup may be sufficient to cause substantial weight gain. With progression of the disease, this

destructive sequence of events can cause the progressive deterioration and eventual failure of the remaining functional heart muscle.

Treatments for congestive heart failure may involve rest, dietary changes, and modified daily activities. Various drugs may also be used to alleviate detrimental effects of congestive heart failure, such as by dilating expanding blood vessels, improving and/or increasing pumping of the remaining healthy heart tissue, increasing the elimination of waste fluids, and the like.

Surgical interventions have also been applied for treatment of congestive heart failure. If the heart failure is related to an abnormal heart valve, the valve may be surgically replaced or repaired. Techniques also exist for exclusion of the scar and volume reduction of the ventricle. These techniques may involve (for example) surgical left ventricular reconstruction, ventricular restoration, the Dor procedure, and the like. If the heart becomes sufficiently damaged, even more drastic surgery may be considered. For example, a heart transplant may be the most viable option for some patients. These surgical therapies can be at least partially effective, but typically involve substantial patient risk. While people with mild or moderate congestive heart failure may benefit from these known techniques to alleviate the symptoms and/or slow the progression of the disease, less traumatic, and therefore, less risky therapies which significantly improve the heart function and extend life of congestive heart failure patients has remained a goal.

It has been proposed that an insert or implant be used to reduce ventricular volume of patients with congestive heart failure. With congestive heart failure, the left ventricle often dilates or increases in size. This can result in a significant increase in wall tension and stress. With disease progression, the volume within the left ventricle gradually increases and blood flow gradually decreases, with scar tissue often taking up a greater and greater portion of the ventricle wall. By implanting a device which brings opposed walls of the ventricle into contact with one another, a portion of the ventricle may be excluded or closed off. By reducing the overall size of the ventricle, particularly by reducing the portion of the functioning ventricle chamber defined by scar tissue, the heart function may be significantly increased and the effects of disease progression at least temporarily reversed, halted, and/or slowed.

An exemplary method and implant for closing off a lower portion of a heart ventricle is described in U.S. Pat. No. 6,776,754, the full disclosure of which is incorporated herein by reference. A variety of alternative implant structures and methods have also been proposed for treatment of the heart. U.S. Pat. No. 6,059,715 is directed to a heart wall tension reduction

apparatus. U.S. Pat. No. 6,162,168 also describes a heart wall tension reduction apparatus, while U.S. Pat. No. 6,125,852 describes minimally-invasive devices and methods for treatment of congestive heart failure, at least some of which involve reshaping an outer wall of the patient's heart so as to reduce the transverse dimension of the left ventricle. U.S. Pat. No. 6,616,684  
5 describes endovascular splinting devices and methods, while U.S. Pat. No. 6,808,488 describes external stress reduction devices and methods that may create a heart wall shape change. US Patent Publication No. US2009/0093670 describes structures and methods for treating dysfunctional cardiac tissue, while US Patent Publication No. US2010/0016655 describes cardiac anchor structures, methods, and systems for treatment of congestive heart failure and  
10 other conditions. The full disclosures of all of these references are incorporated herein by reference in their entirety.

While the proposed implants, systems, and methods may help surgically remedy the size of the ventricle as a treatment of congestive heart failure and appear to offer benefits for many patients, still further advances would be desirable. In general, it would be desirable to provide improved  
15 devices, systems, and methods for treatment of congestive heart failure. It would be particularly desirable if such devices and techniques could provided increased control over any movement of the components of the implant system during deployment in a beating heart, and/or could decrease the trauma imposed on collateral tissues when gaining access to the target tissues for treatment, when positioning implants and other therapeutic devices for use, and when treating the  
20 target tissue. It would be also be beneficial to enhance the accuracy of ventricular reconstruction while simplifying the overall procedure, ideally while decreasing the sensitivity of the therapy on unusual surgical skills. It would be advantageous if these improvements could be provided without overly complicating the structures of implants or implant deployment systems, and while significantly enhancing the benefits provided by the implanted devices.

## 25 BRIEF SUMMARY OF THE INVENTION

Embodiments of the invention provide for a minimally invasive access tool. In a first aspect, embodiments of the invention provide a system for engaging epicardial tissue of a patient's heart. The system may include an elongate tool body extending between a proximal end and a distal end. The elongate tool body may be insertable through a body wall of the patient and the  
30 elongate tool body may have a working lumen throughwhich an intracardiac device is inserted to perform a medical procedure within a chamber of the heart. The system may also have a gripping device near the distal end of the elongate tool body and operable therewith. The

gripping device may be disposed radially outwardly of the working lumen and may be configured to be releasably attached to the epicardial tissue of the heart around the working lumen and an access site of the intracardiac device when performing the medical procedure within the chamber. The gripping device may be coupled with an actuator that is articulatable  
5 from outside the patient body so as to move the gripping device radially inwardly toward an axis of the elongate tool body and thereby facilitate stabilizing or hemostasis of the heart about the intracardiac device.

In some embodiments, the gripping device comprises a suction device. The suction device may include a suction pad at the distal end of the elongate tool body and the suction pad may include  
10 a plurality of suction ports in fluid communication with a suction lumen.

In other embodiments, the suction device may be an arcuate suction channel. The arcuate suction channel may have a plurality of suction ports positioned on a bottom surface that contact the epicardial tissue. The suction ports may releasably attach the gripping device to the epicardial tissue via suction through the suction ports. In some embodiments, one or more of the  
15 suction ports includes a suction pad composed at least in part of resilient material that allows the suction pad to be pressed against and engage the epicardial tissue. The suction port may be positioned toward a center of the suction pad. The arcuate suction channel may include a radially extending slot that allows the arcuate suction channel to be inserted over the elongate  
20 tool body by inserting the elongate tool body through the slot. The opposing ends of the arcuate suction channel (i.e., the ends adjacent the slot) may be circumferentially movable upon operation of an actuation mechanism to apply a contracting force to the epicardial tissue engaged by the arcuate suction channel to thereby facilitate stabilizing or hemostasis of the heart about the intracardiac device. Alternatively or additionally, the arcuate suction channel may be  
25 configured to radially contract upon operation of an actuation mechanism to apply a contracting force to the epicardial tissue engaged by the arcuate suction channel. The arcuate suction channel may further include an aperture shaped and sized to receiveably couple with an outer surface of the elongate tool body.

In some embodiments, the gripping device may be a plurality of elongate members coupled with the elongate tool body and extending radially outwardly from the distal end of the elongate tool  
30 body. The elongate members may be engagable with the epicardial tissue to facilitate stabilizing or hemostasis of the heart about the intracardiac device. The plurality of elongate members may

be movable radially inwardly toward an axis of the elongate tool body upon operation of an actuator so as to provide a radially directed force to the epicardial tissue engaged by the plurality of elongate members. The system may further include a tension member coupled toward a distal end with each of the plurality of elongate members. The tension member may be operable with  
5 the actuator to move the plurality of elongate members radially inwardly upon operation of the actuator. The system may additionally include an outer sheath disposed over the plurality of elongate members. The outer sheath may be operable with the actuator to move the plurality of elongate members radially inwardly upon operation of the actuator by distally advancing the outer sheath over the plurality of elongate members. The actuator may include a handle that is  
10 grasped by a user's hand and a ratchet mechanism.

In another aspect, embodiments of the invention provide a tissue engagement device including an arcuate suction channel having a plurality of suction ports configured to releasably engage epicardial tissue of a patient's heart via suction through the plurality of suction ports. The tissue engagement device may also include a suction lumen in fluid communication with the arcuate  
15 suction channel. The suction lumen may be couplable with a suction device disposed external to the patient to provide suction to the arcuate suction channel. The tissue engagement device may further include an access slot extending radially from a centrally located aperture. The access slot may allow the arcuate suction channel to be inserted over a cannula or working lumen that facilitates in performing a medical procedure within a chamber of the patient's heart. The  
20 centrally located aperture may be shaped and sized to receive the cannula and be releasably secured thereto.

In another aspect, embodiments of the invention provide a device for accessing tissue within a patient's heart. The device may include an elongate tool body extending between a proximal end and a distal end. The elongate tool body may be insertable through a body wall of the patient  
25 and may have a working lumen therethrough. The working lumen may be configured for receiving an intracardiac device to perform a medical procedure within a chamber of the heart. The device may also include a plurality of grippers near the distal end of the elongate tool body and operable therewith. The grippers may be disposed radially outwardly of the working lumen and may be configured to be releasably attached to the epicardial tissue of the heart around the  
30 working lumen and an access site of the intracardiac device when performing the medical procedure within the heart. The grippers may also be coupled to the elongate tool body by an actuator, the actuator being articulatable from outside the patient body so as to move the grippers

radially inwardly toward an axis of the elongate tool body so as to facilitate hemostasis of the heart about the intracardiac device. In some embodiments, the grippers may be a plurality of elongate members that are insertable within or otherwise engageable with the epicardial tissue. In other embodiments, the grippers may be a suction device engageable with the epicardial tissue.

- 5 In another aspect, embodiments of the invention provide a method for accessing tissue within a patient's heart. The method may include providing an elongate tool body, the elongate tool body extending between a proximal end and a distal end and the elongate tool body comprising a working lumen extending between the proximal end and the distal end. The method may also include providing a gripping device, the gripping device being releasably attachable to the
- 10 elongate tool body to facilitate in performing a medical procedure within a chamber of the heart. The method may further include positioning the elongate tool body through a body wall of the patient to adjacent the epicardial tissue of the heart. The method may additionally include inserting an intracardiac device through the working lumen and through the epicardial tissue of the heart at an access site so that a distal end of the intracardiac device is within the chamber.
- 15 The method may additionally include releasably affixing the gripping device to the epicardial tissue of the heart so that the gripping device is disposed about the access site and contracting the gripping device so as to facilitate stabilizing or hemostasis of the heart about the intracardiac device.

#### BRIEF DESCRIPTION OF THE DRAWINGS

- 20 Figs. 1A-D illustrate various views of a healthy heart and a heart having infarcted tissue.
- Fig. 2A shows a reconstructed left ventricle using a series of implanted anchors so as to mitigate the deleterious effects of congestive heart failure, according to an embodiment of the invention.
- Fig. 2B is a cross-sectional view of the heart of FIG. 2A, showing a reduction in the size of the left ventricle effected by one of the implants.
- 25 Figs. 2C-2D schematically illustrate minimally invasive access to and endoscopic imaging of a pericardium of the heart.
- Figs. 3A-3O illustrate a method of reducing the distance between opposing walls of a heart, according to an embodiment of the invention.



Fig. 4A schematically illustrates joining of a femoral access tool path through the right atrium and an endoscopic trans-epicardial access tool path by snaring a guidewire within the right ventricle of the heart, according to an embodiment of the invention.

5 Fig. 4B schematically illustrates introducing a guidewire into a right ventricle of the heart through an external wall of the left ventricle and through the septum so as to form an epicardial access path, according to an embodiment of the invention.

10 Figs. 4C-4E schematically illustrate joining a right atrial access tool shaft with an endoscopic trans-epicardial access tool shaft within the right ventricle by coupling a guidewire and snare advanced along the shafts and into the right ventricle, according to an embodiment of the invention.

Figs. 5A and 5B schematically illustrate alternative techniques for joining a right atrial access tool shaft and an endoscopic epicardial access tool by snaring a guidewire within the right ventricle or right atrium of the heart using a basket snare, according to an embodiment of the invention.

15 Fig. 6 illustrates a basket snare and associated access catheter configured for use in the right ventricle, according to an embodiment of the invention.

Fig. 7 schematically illustrates joining a right-atrial access tool path with a trans-epicardial access tool using a snare and associated guidewire configured for coupling within the pulmonary artery, according to an embodiment of the invention.

20 Fig. 8 schematically illustrates a guidewire that has been pulled along paths joined within the right ventricle so as to extend from outside the patient, through the right atrium, through the right ventricle, through the septum, through the left ventricle, through an exterior wall of the heart, and back outside the patient, according to an embodiment of the invention.

25 Figs. 9 schematically illustrates expansion of a path through the left ventricle over a guidewire, delivery of an anchor and adjacent tension member through the expanded path and over the guidewire, and controlling movement and orientation of the anchor within the right ventricle using a guidewire extending along a joined path, according to an embodiment of the invention.

Figs. 10-10F illustrates components of an over-the-wire implant delivery system and their use, according to an embodiment of the invention.

Figs. 10G-10I illustrate an exemplary axially flexible helical screw-tip dilator and its use for traversing a wall of the heart, according to an embodiment of the invention.

Figs. 11A-11C illustrate an alternative over-the-wire dilating catheter, according to an embodiment of the invention.

- 5 Figs. 12A and 12B schematically illustrate an anchor repositioning leash and its use, according to an embodiment of the invention.

Figs. 13A-13C schematically illustrate coupling of a tension member to a guidewire so as to facilitate guiding the tension member into and through the heart, according to an embodiment of the invention.

- 10 Figs. 14A-14C schematically illustrate advancing the tension member and anchor along a right ventricle access tool over a guidewire, and out from the access tool and through the septum and an external wall of the left ventricle, according to an embodiment of the invention.

Figs. 15A-15D illustrate various aspects of an epicardial anchor having a variable-force mode and a set force mode, according to an embodiment of the invention.

- 15 Figs. 16A-16F illustrate an epicardial hemostasis tool having a working lumen to provide access through a tissue tract to an epicardium about an epicardial access path, wherein the tool is configured to compress the external wall of the heart toward the access path so as to provide hemostasis, according to an embodiment of the invention.

- 20 Figs. 17-18B illustrate alternative epicardial anchors which are adapted to be advanced along and reconfigured between a variable-force mode and a set force mode via a working lumen of a minimally invasive epicardial access device, according to an embodiment of the invention.

- 25 Figs. 19A-D illustrate insertion of an epicardial-engagement portion of an anchor over a tension member and through a working lumen of a minimally-invasive access device so as to distribute an anchoring load of an anchor lock along a desired contour, according to an embodiment of the invention.

Figs. 20-22 illustrate various alternative embodiments of an epicardial hemostasis tool, wherein the tool is configured to compress the external wall of the heart toward an access path of an intracardiac device, according to an embodiment of the invention.

## DETAILED DESCRIPTION OF THE INVENTION

The present invention generally provides improved medical devices, systems, and methods. Exemplary embodiments of the devices are described for use in reducing the distance between a region along the septum and a region of an external wall of the left ventricle of a heart in a less or minimally invasive manner. Hence, embodiments of the tools and methods described herein may find specific use in the treatment of congestive heart failure and other progressive heart diseases by reconfiguring abnormal heart geometry that may be contributing to heart dysfunction. For congestive heart failure therapies, perforating both the exterior wall and the septum from an epicardial approach can provide significant benefits in control over the locations of implant deployments, thereby effectively enhancing the resulting reshaping of the ventricular chamber. In some embodiments of the invention, the exterior wall and the septum may be perforated using a curved needle. The perforated septum and/or exterior wall may then be dilated to expand or enlarge the aperture through the septum or exterior wall using a dilating catheter, which may include a dilating feature such as a tapering threaded tip, cutting element (RF cutting element), and the like. The dilating catheter may dilate the aperture, such as by cutting tissue, as the dilating catheter is inserted through the exterior wall and/or septum without requiring an excessive axial force to be placed on the exterior wall and/or septum. This may reduce or eliminate arrhythmia or other negative conditions caused by excessive axial pressure exerted on the exterior wall and/or septum. In addition, this wall and/or septum perforation process can be performed while the heart is beating.

In another embodiment, guiding or deploying an implant may involve both the epicardial access path and another access path into and via an access path through the right ventricle. This additional right atrial access path into the heart may be via the superior vena cava, the inferior vena cava, the right atrial appendage, or the like, and the pathways may be joined together by coupling of a snare to a guidewire or the like within the right ventricle, the right atrium, the right pulmonary artery, or the like. While a variety of tools will be described herein for providing access pathways, for joining pathways together within the heart, for deploying implants, for maintaining hemostasis, and the like, it should be recognized that alternative embodiments may employ additional or alternative structures, some of which may be off-the-shelf, and some of which may be new structures configured particularly for use in the advantageous therapies described herein. For example, embodiments of the systems, implants, and techniques described herein may employ components described in US2009/0093670, as published on April 9, 2009

and entitled "Treating Dysfunctional Cardiac Tissue;" and/or in US Patent Publication No. US2010/0016655, as published on January 21, 2010 and entitled "Cardiac Anchor Structures, Methods, and Systems for treatment of Congestive Heart Failure and Other Conditions;" the full disclosures of which are incorporated herein by reference in their entirety.

- 5 Deployment of an anchor within the heart (e.g., the right ventricle) both along a single pathway or joined pathways described above, may be improved by guiding the anchor into the heart over a guidewire. The anchor and/or a tether coupled to the anchor may include a lumen through which the guidewire is inserted that aligns and controls the placement of the anchor within the heart and/or controls deployment of the anchor within the heart. Such placement of
- 10 the anchor and/or control of the anchor may prevent or reduce the anchor from entangling or interfering with sensitive heart tissues, such as valve leaflets, chordae, papillary muscles, and the like. The guidewire may be positioned within a chamber of the heart (ventricle or atrium), within an artery (e.g., the pulmonary artery), and the like, and the anchor can be advanced to that position over the guidewire so as to avoid sensitive heart tissues. In embodiments where
- 15 separate pathways are joined, the anchor may be inserted along one pathway, advanced over the guidewire to within a chamber of the heart, and a tether coupled with the anchor may be advanced to a position exterior to the heart along the other pathway. The tether may then be tensioned to urge a wall of the heart toward a second wall (e.g., urge the septum toward an exterior wall of the left ventricle).
- 20 Tensioning of the tether and/or anchor and the resulting reshaping of the heart may be improved using a tensioning device and/or second anchor as described herein. The second anchor may be coupled with the tension member and may include a variable-force mode that allows the second anchor to be advanced distally and proximally along the tension member; similarly, the second anchor may also include a set force mode that allows the anchor to only be advanced proximally
- 25 or distally along the tension member (i.e., that inhibits proximal or distal movement of the anchor along the tension member). The second anchor may be reconfigured between the variable-force and set force mode. The tension member, second anchor, and/or first anchor may be tensioned via a minimally invasive tension device or force-application tool. The tension device/force-application tool may be designed to tension the tension member, second anchor,
- 30 and/or first anchor while the heart is beating and may be designed to reconfigure the second anchor between the variable-force and set force mode from outside the patient body. The tension device may provide an indication of the tension force applied, which provides controls over the

tension applied so as to inhibit migration of the first and/or second anchors with respect to the septum and/or exterior wall of the heart.

The deployment anchors may be inserted within the heart through a working lumen of a minimally invasive access tool. The minimally invasive access tool may have a gripper device  
5 disposed at a distal end that contact epicardial tissue of the heart. The gripper device may be affixed to the epicardial surface of the heart and the gripper device may be radially contracted or, in other words, move radially inwardly to facilitate in stabilizing a portion of the heart or provide hemostasis to an intracardiac device inserted through the working lumen and through the epicardial tissue of the heart.

10 Referring now to the figures, Fig. 1A shows a normal heart H and Fig. 1B shows the cross-section of normal heart H. Normal heart H includes structures such as the aorta AO, pulmonary artery PU, coronary artery CA, apex AP, right ventricle RV, left ventricle LV with a radius 210, and septum SE.

Myocardial infarction and the resultant scar formation is often the index event in the genesis of  
15 congestive heart failure ("CHF"). The presence of the scar, if left untreated, may lead to a compensatory neuro-hormonal response by the remaining, non-infarcted myocardium. FIG. 1C shows a region RE (bordered by a dotted line) of left ventricle LV which includes scar tissue. With congestive heart failure, the left ventricle often dilates or increases in size as shown in FIG. 1D, in which radius 210 has increased to a radius 410. This increase in size can result in a  
20 significant increase in wall tension and stress. With disease progression, the volume of the left ventricle LV gradually increases while forward blood flow gradually decreases, with scar tissue expanding while unscarred muscle dilates and becomes thin, losing contractility. The systems, methods, and devices described herein may be applied to inhibit, reverse, or avoid this response altogether, often halting the destructive sequence of events which could otherwise cause the  
25 eventual failure of the remaining functional heart muscle.

CHF is a condition in which the heart does not pump enough blood to the body's other organs. CHF may result from narrowing of the arteries that supply blood to the heart muscle, for instance, the coronary artery CA as shown in FIGS. 1 and 1C. Other causes of CHF include high  
30 blood pressure, heart valve dysfunctions due to degenerative processes or other causes, cardiomyopathy (a disease of the heart muscle itself), congenital heart defects, infections of the heart tissues, and the like. In certain pathological conditions, the ventricles of the heart can

become ineffective in pumping the blood, causing a back-up of pressure in the vascular system behind the ventricle. The reduced effectiveness of the heart may be due to an enlargement of the heart. For example, the left ventricular radius 210 of a heart H, as shown in FIGS. 1 and 1B, may eventually increase to a larger left ventricular radius 410 of a failing heart H, as shown in  
5 FIGS. 1C and 1D.

Acute myocardial infarction (AMI) due to obstruction of a coronary artery CA is a common initiating event that can lead ultimately to heart failure. A myocardial ischemia may cause a portion of a myocardium of the heart to lose its ability to contract. Prolonged ischemia can lead to infarction of a portion of the myocardium (heart muscle). Once this tissue dies, it no longer  
10 acts as a muscle and cannot contribute to the pumping action of the heart. When the heart tissue is no longer pumping effectively, that portion of the myocardium is said to be hypokinetic or akinetic, meaning that it is less contractile or acontractile relative to the uncompromised myocardial tissue. As this situation worsens, the local area of compromised myocardium may bulge out as the heart contracts, further decreasing the hearts ability to move blood forward and  
15 dilating a ventricle. This bulged out myocardium can be seen in region RE as shown bordered by a dotted line in FIG. 1C.

As shown in FIGS. 1C and 1D, one problem with a large dilated left ventricle is a significant increase in wall tension and/or stress both during diastolic filling and during systolic contraction. In a normal heart, the adaptation of muscle hypertrophy (thickening) and ventricular dilatation  
20 maintain a fairly constant wall tension for systolic contraction. However, in a failing heart, the ongoing dilation is greater than the hypertrophy and the result is a rising wall tension requirement for systolic contraction. This rising wall tension requirement may be an ongoing insult to the muscle myocytes (heart muscle cells), resulting in further muscle damage. In response, the heart tissue often remodels to accommodate the chronically increased filling  
25 pressures, further increasing the work that the now-compromised myocardium must perform. This vicious cycle of cardiac failure may result in the symptoms of CHF such as shortness of breath on exertion, edema in the periphery, nocturnal dyspnea (a characteristic shortness of breath that occurs at night after going to bed), weight gain, and fatigue, to name a few. The increase in wall stress also occurs during throughout the cardiac cycle and inhibits diastolic  
30 filling. The stress increase requires a larger amount of oxygen supply, which can result in exhaustion of the myocardium leading to a reduced cardiac output of the heart.

- Embodiments of the invention may build on known techniques for exclusion of the scar and volume reduction of the ventricle. Unlike known techniques that are often accomplished through open surgery, including left ventricular reconstruction, ventricular restoration, the Dor procedure, and the like, the treatments described herein will often (though not necessarily always) be
- 5 implemented in a minimally invasive or less invasive manner. Embodiments of the invention can provide advantages similar to those (for example) of surgical reconstruction of the ventricle, resulting in improved function due to improved dynamics, and by normalizing the downward cycle initiated by the original injury and mediated by the neuro-hormonal disease progression response.
- 10 Advantageously, the methods, devices, and systems described herein may allow percutaneous left ventricular scar exclusion and ventricle volume reduction to be applied at any appropriate time during the course of the disease. Rather than merely awaiting foreseeable disease progression and attempting to alleviate existing cardiac dysfunction, the techniques described herein may be applied proactively to prevent some or all of the heart failure symptoms, as well as
- 15 to reverse at least a portion of any existing congestive heart failure effects, to limit or halt the progression of congestive heart failure, and/or to retard or prevent congestive heart failure disease progression in the future. Some embodiments may, for appropriate patients, limit the impact of myocardial infarction scar formation before heart failure even develops.
- Referring now to Figs. 2A and 2B, a series of implants 10 are shown implanted in a heart H so as
- 20 to decrease a cross-section of a left ventricle LV. Each implant 10 generally includes a first anchor 12, a second anchor 14, and a tension member 16 coupling the anchors together. Tension in the tension member 16 is transferred from the anchors 12, 14 to the septum S and the external wall EW bordering the left ventricle LV so as to bring these structures into engagement, thereby effectively excluding a region of scar tissue ST from the left ventricle. In many embodiments
- 25 described herein, implant 10 will be deployed by penetrating the external wall EW and septum SE via a pericardium P of the heart H, and also by accessing a right ventricle RV via a right atrium. Anchors deployed within a right ventricle and/or in engagement with the septum SE may sometimes be referred to herein as septal anchors, while anchors deployed along the external wall EW of the left ventricle LV may be referred to as epicardial anchors.
- 30 Referring now to Figs. 2C and 2D an MRI image I taken along viewing plane VP schematically illustrates use of a thoracoscope 20 to provide a field of view encompassing a region of the

pericardium of the heart, with the region including a target site for deployment of one or more epicardial anchors of the implant system.

Referring now to Figs. 3A – 3O, shown is a method of reducing the distance between opposed walls of a heart H, and specifically of reducing the distance between the septum SE and the external wall EW of the left ventricle LV. In some embodiments, the method is performed  
5 endoscopically, percutaneously, or otherwise in a minimally or less invasive manner. The heart may be accessed through, for example, a small incision made between the ribs or a thoracotomy. As shown in Fig. 3A, a bent insertion needle or guidewire introducer 320 is passed through a desired insertion path through the left ventricle LV wall and through septum SE into the right  
10 ventricle RV. Guidewire introducer 320 may be configured so that the perforations made by guidewire introducer 320 on the left ventricular wall and the septum wall are perpendicular to their respective walls. As shown in Fig. 3B, a guidewire 311 is placed through the lumen of guidewire introducer 320 so that guidewire 311 threads through the outer left ventricle LV wall, through the septum SE, and into the right ventricle RV. Guidewire 311 may be inserted along  
15 and may define an epicardial access path, which may be an arcuate path. As shown in Fig. 3C, guidewire introducer 320 is removed from the heart leaving guidewire 311 threaded through the external wall EW, left ventricle LV, and septum SE into right ventricle RV. Examples of bent insertion needle or guidewire introducer 320 may be found in US Patent Publication No. US2010/0016655 that is incorporated herein by reference as described previously.

20 Fig. 3D shows a dilating catheter 324 inserted within a lumen of a delivery catheter 326 with the dilating catheter 324 and delivery catheter 326 being advanced over the guidewire 311 to external wall EW of heart H. Delivery catheter 326 may include a hemostasis valve at a proximal end outside the heart to minimize blood loss from the patient. Guidewire 311 is inserted through a lumen of dilating catheter 324. Additional aspects of dilating catheter 324 and  
25 delivery catheter 326 are shown in Fig. 10. In other embodiments, such as the embodiments illustrated in Figs. 11A – 11C the delivery catheter and dilating catheter may be combined into a single catheter device.

Fig. 3E shows the dilating catheter 324 and delivery catheter 326 inserted over guidewire 311 through the external wall EW and into left ventricle LV so that the distal tip of dilating catheter  
30 324 is proximate septum SE. Dilating catheter 324 and delivery catheter 326 may comprise a



flexible material so as to curve or bend along the arcuate epicardial access path defined by guidewire 311.

Dilating catheter 324 may dilate or enlarge an aperture in septum SE and/or external wall EW formed from inserting guidewire introducer 320 through septum SE and/or external wall EW.

- 5 To dilate the aperture through septum SE and/or external wall EW, dilating catheter 324 includes a dilating feature at the distal tip. For example, in some embodiments, dilating catheter 324 comprises a tapering threaded tip 325 as shown in more detail in Fig. 10. Dilating catheter 324 may be rotated 323 about an axis as dilating catheter 324 is inserted through septum SE and/or external wall EW to dilate the aperture. The threaded surface of tapering threaded tip 325
- 10 contacts tissue of the septum SE and/or external wall EW and cuts the tissue, compresses the tissue, or otherwise widens the aperture. The tapered threaded tip 325 reduces the amount of axial pressure that is otherwise applied to septum SE and/or external wall EW as a delivery catheter is inserted therethrough, which may reduce arrhythmia or other conditions resulting from axial pressure exerted on the septum SE and/or external wall EW. In other words, rotation
- 15 of tapering threaded tip 325 may help advance delivery catheter 326 with less axial force than would otherwise be used to axially advance a tapered catheter, and may limit axial force to the septum sufficiently to inhibit arrhythmia of the heart. The tissue contacted by the tapered threaded tip 325 may include scar tissue ST, which generally is tough or otherwise difficult to penetrate and which, therefore, requires an appreciable amount of axial force to penetrate.
- 20 Dilating catheter 324 and/or delivery catheter 326 may be formed of a flexible material so that dilating catheter 324 may be rotated while being bent along the arcuate epicardial access path of guidewire 311. Put another way, rotation of dilating catheter 324 may be transmitted axially over guidewire 311 around the arcuate epicardial access path. Dilating catheter 324 may alternatively include a cutting element instead of or in addition to tapered threaded tip 325. The
- 25 cutting element may use RF energy (e.g., an RF transseptal needle) to cut through the tissue of the septum SE and/or external wall EW. Such RF devices are described herein. Likewise, delivery catheter 326 and/or dilating catheter 324 may be steerable catheters so that a distal end of catheters, 324 and/or 326, may be positioned virtually anywhere within right ventricle (e.g., near the pulmonary artery and the like).

- 30 Figs. 10G-10I illustrate an alternative embodiment of a dilation catheter 324' having a tapered threaded tip 325'. In this embodiment, tapered threaded tip 325' is configured to rotationally advance or screw into and through tissue of external wall EW and/or septum SE. Dilation

catheter 324' includes inner and outer concentric shafts that extend proximally of tapered threaded tip 325' toward a proximal hub 323'. The shafts are laterally flexible to accommodate curvature of the axis of the dilation catheter, and the hub 323' and tapered threaded tip 325' may be axially coupled to the inner shaft and the inner shaft may be sufficiently axially stiff so that rotation of the hub 323' outside the body induces controlled rotation of the tapered threaded tip 325' into and through the tissue of external wall EW and/or septum SE while the outer shaft remains rotationally stationary.

Fig. 3F shows the dilating catheter 324 and delivery catheter 324 advanced along the arcuate epicardial access path over guidewire 311 through septum wall SE and into right ventricle RV after dilating catheter 324 has dilated or expanded the aperture through septum SE and/or external wall EW, which, as described previously, may involve contacting and/or cutting scar tissue ST. Fig. 3G shows the dilating catheter 324 removed from the lumen of delivery catheter 326 so that delivery catheter 326 remains within right ventricle RV and inserted through septum SE and external wall EW.

Fig. 3H shows septal anchor 332 being inserted within a proximal end of delivery catheter 326. Septal anchor 332 is positioned within loading cartridge 334 that fits at a distal end within the hemostasis valve of delivery catheter 326 and that couples at a proximal end with pusher tube 336. Loading cartridge 334 facilitates insertion of septal anchor 332 and pusher tube 336 within delivery catheter 326. Additional aspects of septal anchor 332, loading cartridge 334, and pusher tube 336 are shown in Fig. 10. Septal anchor 332 is rotatably coupled with tether or tension member 333 at pivot point 333a. Septal anchor 332 includes a lumen through which guidewire 311 is inserted so that septal anchor 332 is advancable over the guidewire. The lumen of septal anchor 332 may extend along an axis of the septal anchor 332. The lumen may slidably receive guidewire 311 therein so as to accommodate advancement of septal anchor 332 into heart H by advancing septal anchor 332 axially over guidewire 311 and into the right ventricle RV. Guidewire 311 may help control a position of septal anchor 332 and inhibit injury to tissue structures along or within the heart H, right ventricle RV, and/or left ventricle LV, such as valve leaflets, chordae, papillary muscles, and the like.

Similarly, pusher tube 336 includes a guidewire lumen (e.g., guidewire lumen 339 shown in Fig. 10F), through which guidewire 311 may be inserted. When guidewire 311 is inserted through the lumen of septal anchor 332 and pusher tube 336, guidewire 311 orients septal anchor 332 in a

fixed orientation (i.e., a low profile configuration) and axially aligns the lumens of septal anchor 332 and pusher tube 336. The low profile configuration allows septal anchor 332 to be easily inserted within and pushed through the lumen of delivery catheter 326. Pusher tube 336 also includes a tether lumen, (e.g., tether lumen 341 shown in Fig. 10F), through which tether 333 is  
5 inserted.

Fig. 3I illustrates septal anchor 332 advanced through delivery catheter 326 via pusher tube 336 into the right ventricle RV of heart H over guidewire 311. Guidewire 311 maintains septal anchor 332 in the axially aligned relationship with pusher tube 336 and tether 333. Fig. 3I also shows the guidewire 311 exiting pusher tube 336 via guidewire port 343 and shows tether 333  
10 exiting pusher tube 336 via tether port 345. Additional aspect of guidewire port 343 and tether port 345 are shown in Fig. 10. Because septal anchor 332 is guided into the right ventricle RV over guidewire 311, septal anchor 332 may be positioned virtually anywhere guidewire 311 is positioned, such near the pulmonary artery and the like. Such positionability of septal anchor 332 allows sensitive heart tissues, such as valve leaflets, chordae, papillary muscles, and the like,  
15 to be avoided or contact therewith minimized. Further, positioning septal anchor 332 over guidewire 311 minimizes entanglement with and/or contact between septal anchor 332 and sensitive heart tissues, such as valve leaflets, chordae, and the like, because septal anchor 332 is fixed in relation to tether 333 and pusher tube 336 and not able to freely rotate and entangle with or contact such features of heart H.

20 Septal anchor 332 may optionally be advanced into and/or within heart H by pushing the anchor distally using a flexible compressive shaft of pusher tube 336, 1036, or the like. In either case, the compressive shaft being used as a pusher catheter may have separate lumens for guidewire 311 and tether 333 as shown, with both lumens extending between the distal end and the proximal end of the catheter body. More than 2 lumens may also be provided, and the multi-  
25 lumen structure can enhance rotational control over septal anchor 332 about the axis of tether 333, and/or may facilitate orienting the arms of septal anchor 332 by rotation of the pusher tube 336/1036 (optionally along with tether 333 and guidewire 311 therein) from outside the patient. In some embodiments, tether 333 may have an elongate cross-section and tether lumen 341/1041 may have a corresponding elongate cross-section so as to enhance rotational control over the  
30 advanced septal anchor 332 after guidewire 311 is pulled free of septal anchor 332, as can be understood with reference to the distal end of pusher tube 1036 shown in Fig. 10C, and with reference to the elongate cross-section of the large tether lumen 341 of pusher catheter 336

shown in Fig. 10F. In some embodiments, one of the unnumbered lumens on either side of guidewire lumen 339 may receive guidewire 311.

Fig. 3J shows guidewire 311 being removed from the right ventricle via guidewire port 343 and from the guidewire lumen of septal anchor 332. Removal of guidewire 311 from the guidewire  
5 lumen of septal anchor 332 allows septal anchor 332 to pivot about pivot point 333a so that septal anchor 332 is rotatable relative to tether 333. Control over the pivoting of septal anchor 332 may be provided by using leash 312 as shown in Figs. 12A – 12B. For example, once septal anchor 332 is disposed within right ventricle RV and beyond delivery catheter 326, guidewire 311 can be removed and septal anchor 332 positioned transverse to tether 333 by engagement  
10 between septal anchor 332 and the surface of septum SE, or by pulling on leash 312 extending through catheter 326 or pusher tube 336. Radial positioning of septal anchor 332 can be provided by rotating the end of tether 333, which remains outside the patient.

Fig. 3J further shows a laterally deployable member 328, such as deployable arms 1031 of pusher tube 1036 of Figs. 10B – 10C, deployed from the distal end of pusher tube 336 so as to  
15 stabilize the pusher tube 336 and delivery catheter 326 relative to the beating heart tissue around left ventricle LV. Suitable deployable members 328 may include a malecot, a pair of opposed deployable arms (optionally similar to those described below with reference to Figs. 10B and 10C), a balloon, or the like. Laterally deployable member 328 may be configured for engagement against an interior surface of the left ventricle LV or against the epicardial surface of  
20 the left ventricle (such as by having the deployable structure spaced proximally of the distal end). Laterally deployable member 328 may be used to urge septum SE toward external wall EW and thereby provide additional space within right ventricle RV for the deployment of septal anchor 332 and/or may facilitate tensioning of septal anchor 332 and an epicardial anchor to reshape heart H. Some embodiments do not involve laterally deployable member 328 and septal anchor  
25 332 is deployed directly within the space of right ventricle RV. Deployable members 328 may be deployed within right ventricle RV before or after guidewire 311 is removed and septal anchor 332 released from the fixed orientation.

Fig. 3K shows delivery catheter 326 and pusher tube 336 being removed from the right ventricle RV of heart H so that septal anchor 332 is positioned against the surface of the wall of septum  
30 SE. Tether 333 extends from septal anchor 332 through the aperture in septum SE and external wall EW to the exterior of heart H. Tension may be applied to tension member 333 to urge

septum SE toward external wall EW. Fig. 3L shows an epicardial anchor 355 coupled with tension member 333 and being advanced toward external wall EW via anchor set tool 359. Epicardial anchor 355 includes a lumen 353 (shown in Figs. 10, 10D, 10E, and 15A – 15D), through which tether 333 is inserted. Epicardial anchor 355 has a spring cam structure 363 as  
5 more fully shown in Figs. 15A – 15D and described in US Patent Publication No. US2010/0016655, as published on January 21, 2010 and entitled “Cardiac Anchor Structures, Methods, and Systems for treatment of Congestive Heart Failure and Other Conditions;” the full disclosures of which are incorporated herein by reference. The spring cam 363 allows epicardial anchor 355 to slide along tether 333 toward septal anchor 332, but inhibits sliding of epicardial  
10 anchor 355 away from septal anchor 332, so that the spring cam 363 effectively maintains a tissue engagement force between the anchors. This set-force interaction between tether 333 and epicardial anchor 355 is advantageous once the proper force is applied, but it can be challenging to apply the desired force when the heart is beating. To more accurately apply septal/external wall engagement forces within a desired range, anchor set tool 359 can engage the cam spring  
15 mechanism 363 of epicardial anchor 355 so as to allow the anchor to slide both axial directions along tether 333 (shown in Fig. 10E), thereby configuring epicardial anchor 355 into a variable force mode. This allows a controlled force to be applied between the tether 333 and epicardial anchor 355 despite beating of the heart, with the force preferably being applied by a force application tool 314 having an elongate shaft 316 as described in Fig. 3M.

20 The applied anchor force may be an appropriate amount of force to bring external wall EW and septum SE into engagement while preventing migration of epicardial anchor 355 and septal anchor 332 relative to external wall EW and septum SE, respectively. For example, the force may be sufficient so that an inner surface of external wall EW and septum SE directly contact each other and so that epicardial anchor 355 and septal anchor 332 are secured tightly about  
25 external wall EW and septum SE, respectively, but not too strong to cause epicardial anchor 355 and/or septal anchor 332 to be pulled through and/or into external wall EW and/or septum SE. The appropriate anchor force to sufficiently secure the anchors about the heart walls while preventing migration may fall within a range of forces, which may vary from patient to patient. In some embodiments, the anchor force range may be between about 2 newtons and about 6  
30 newtons and in other embodiments, may be between about 3 newtons and about 4 newtons. Such forces were found to be sufficient enough to prevent migration of the anchors without cause the anchors to be pulled through the external wall EW and/or septum SE. Such forces

were also found to minimize necrosis of the tissue of external wall EW and/or septum SE surrounding the anchors.

The force application tool 314 may provide an indication (e.g., via indicia 315) of the force applied so that a force within the desired force range may be applied to the anchors. Further, force application tool 314 and/or epicardial anchor 355 may be configured to apply the appropriate force while the heart is beating. For example, the variable force mode of epicardial anchor 355, allowing proximal and distal movement of epicardial anchor 355 about tether 333, and/or a spring mechanism 313 of force application tool 314 may allow epicardial anchor 355 and force application tool 314 to compensate for movement of heart H as the heart beats and as the desired anchor force is applied to ensure that too little or too much force is not applied. Force application tool 314 may also be configured so that the applied anchor force cannot exceed a predetermined value. For example, force application tool 314 may be configured so that an operator of force application tool 314 cannot apply an anchor force greater than 6 newtons, or in some embodiments, greater than 4 newtons. In this manner, necrosis of heart tissue, migration of the anchors, pulling of the anchors through the heart tissue, and/or other potential problems associated with excessive or insufficient anchor forces may be minimized or eliminated.

As shown in greater detail in Figs. 10D, 10E, and 15A – 15D, to engage the cam spring mechanism 363 of epicardial anchor 355, anchor set tool 359 may include a pair of hooks 368 that are positionable around a pair of arms 364 that are in turn connected to cam spring mechanism 363 or otherwise operational therewith. A retractable rod 367 may be positioned between the pair of hooks 368. Rod 367 may be retracted within a sheath 371 or extended therefrom upon actuation of a retracting device, such as a rotatable cap 357. In operation, the pair of hooks 368 may be clamped around arms 364 so that housing 365 is positioned between hooks 368. Retracting device (e.g., rotatable cap 357) is then operated so that rod 367 extends from sheath 371 and contacts housing surface 366. Further operation of retracting device (e.g., rotatable cap 357) forces rod 367 to push on housing surface 366, which causes hooks 368 to pull on arms 364, which in turn causes cam spring mechanism 363 to rotate so that the cam rotates away from contact with tether 333 thereby permitting epicardial anchor 355 to slide both toward and away from septal anchor 332. Similarly, retracting device (e.g., rotatable cap 357) may be operated in a reverse manner so that rod 367 is retracted within sheath 371 and arms 364 resiliently return to a position in which the cam rotates to contact tether 333 thereby inhibiting epicardial anchor 355 from sliding away from septal anchor 332. Arms 364 may act as a spring

to bias the cam toward tether 333 and lock epicardial anchor 355 about tether 333. The retracting device (e.g., rotatable cap 357) may be operated from outside the patient body so as to lock/reconfigure epicardial anchor 355 in the set force mode or unlock/reconfigure epicardial anchor 255 in the variable force mode.

5 Alternative embodiments of an epicardial anchor structure, 1700 and 1800, are shown in Figs. 17 – 18B. Epicardial anchor structures, 1700 and 1800, can be advanced axially through a working lumen (optionally through a working lumen of the epicardial hemostasis device described herein) and can also be reconfigured between a set-force mode and a variable-force mode through the access lumen. Epicardial anchor structures, 1700 and 1800, may include a lock plate 1720 or a  
10 pair of lock plates within lumen body 1710. The lock plate or plates 1720 may include an aperture through which tether 333 is inserted. Lock plates 1720 may be biased toward a distal end of epicardial anchor structures, 1700 and 1800, via a spring 1730 disposed within lumen body 1710. Locking plates 1720 may pivot within lumen body 1710 to assume a lock position and grip tether 333 and thereby lock epicardial anchor structures, 1700 and 1800, about tether  
15 333 to prevent proximal movement of the anchors relative to tether 333. Locking plates 1720 may also pivot within body lumen 1710 to assume an unlock position and disengage tether 333 and thereby allow epicardial anchor structures, 1700 and 1800, to move distally and proximally relative to tether 333. Spring 1730 may bias locking plates 1720 toward the lock position. For example, the aperture of lock plates 1720 may have a shape corresponding to tether 333 and may  
20 be sized slightly larger than tether 333. In the unlock position, lock plates 1720 may assume a vertical position within lumen body 1710, or put another way, lock plates may have a substantially perpendicular orientation with respect to tether 333. Because the aperture of lock plates 1720 corresponds in shape to tether 333 and is sized slightly larger, tether 333 is able to freely pass through the aperture. In the lock position, lock plates 1720 may assume an angled  
25 orientation with respect to tether 333, which causes the aperture of lock plates 1720 to kink, grip, or otherwise grasp tether 333 and prevents movement of tether 333 through the aperture. In some embodiments, epicardial anchor structures, 1700 and 1800, may move distally along tether 333 when lock plates 1720 are in the lock position and only proximal motion may be limited.

Optionally, reconfiguring locking plates 1720 between the lock and unlock position, or in other  
30 words pivoting the locking plates so as to grip or disengage tether 333, may be effected by axial rotation of a lumen body 1710 as shown in Fig. 17B and 17C. Alternatively, a movable actuator or pin 1802, which engages locking plates 1720 in the unlock position, may be removed to allow

the locking plates 1720 to assume the lock position. Rotation of lumen 1710 and/or removal of pin 1802 may be effected from along a working lumen to reconfigure locking plates 1720.

In operation, epicardial anchor 355 is positioned adjacent external wall EW of heart H and epicardial anchor structure, 1700 or 1800, is inserted over tether 333 in the variable force mode to adjacent epicardial anchor 355. A desired anchor force is then applied to epicardial anchor 355 and septal anchor 332 and epicardial anchor structure, 1700 or 1800, is reconfigured to the set force mode to lock epicardial anchor structure, 1700 or 1800, about tether 333 and prevent proximal movement of epicardial anchor structure, 1700 or 1800, relative to tether 333. The applied anchor force may inhibit migration of the anchors as described herein.

Returning now to Fig. 3L, epicardial anchor 355 may be slide or advanced along tether 333 until epicardial anchor 355 contact external wall EW (shown by position 351). As briefly mentioned above, Fig. 3M shows a force being applied by force application tool 314. Additional aspects of force application tool 314 are shown in Fig. 10. Force application tool 314 may be a relatively simple structure similar to a scale, typically having a force spring 313 and indicia 315 showing when a force in a desired range is being applied such as by showing deflection of the spring to a position within a desired range. By sliding the shaft 316 of the force application tool 314 over tether 333, engaging the surface of epicardial anchor 355 with a compression surface of the shaft 316, and applying force between the tether 333 and the force application tool 314 till the desired deflection is identified, the desired force may be applied between septal anchor 332 and epicardial anchor 355. While that force is applied, anchor set tool 359 may disengage the cam lock mechanism 363 of epicardial anchor 355, thereby reconfiguring epicardial anchor 355 from the variable-force mode to the set-force mode. Alternatively, if epicardial anchor structures, 1700 or 1800, are used, rotatable feature 1702 or movable actuator 1802 may be operated to reconfigure epicardial anchor structures, 1700 or 1800, to the set-force mode and thereby secure or anchor epicardial anchor 355 about tether 333.

The force application tool 314 and anchor set tool 359 can then be removed as shown in Fig. 3N and the tether 333 extending away from the heart from epicardial anchor 355 can be cut and removed, leaving epicardial anchor 355 and septal anchor 332 anchored or secured so that the septum SE and external wall EW contact or so a volume of the left ventricle LV is reduced.

Pressure by epicardial anchor 355 against external wall EW inhibits blood flow out of the left ventricle LV along the epicardial access path, while pressure of septal anchor 332 against the



septum SE inhibits blood flow from the left ventricle LV to the right ventricle RV. Known techniques can be used for closure of the vascular access of delivery catheter 326 and the minimally invasive access to the epicardium. Fig. 3O shows that the above process can be repeated so that multiple epicardial anchors 355 and septal anchors 332 are positioned against the  
5 septum SE and external wall EW to reduce a volume of the left ventricle LV.

Epicardial anchor 355 and/or septal anchor 332 may include an outer layer of ingrowth material, such as layer 362 of Fig. 10D, which promotes scar tissue growth around the anchors. The ingrowth material may comprise a polyester fabric. Similarly, an elongate flexible body 380 of ingrowth material may be positioned between the septum SE and external wall EW as shown in  
10 Fig. 3L to promote tissue growth between the septum SE and external wall EW after the septum SE and external wall are brought into engagement. The flexible body 380 may include an aperture that slidably receives tether 333 therethrough so that flexible body 380 extends laterally from tether 333. The aperture may rotationally couple flexible body 380 to tether 333 so as to facilitate orienting the flexible body 380 by rotation of tether 333. Flexible body 380 may be  
15 positionable between septum SE and external wall EW by advancement of flexible body 380 over tether 333.

Referring now to Figs. 10, 10A, and 10D – 10F, shown are the various tools that may be used in the process described in relation to Figs. 3A – 3O. Figs. 10 and 10A show the delivery catheter 326, which includes a lumen 317 that extends between a proximal end 318 and a distal end 319.  
20 Various other catheters or tools, such dilating catheter 324, loading cartridge 334, and pusher tube 336 may be inserted partially or fully within lumen 317. Delivery Catheter 326 includes a hemostasis valve (not shown) located at the proximal end 318, which minimizes blood loss during the minimally invasive surgery.

Figs. 10, 10A, and 10E show the dilating catheter 324 having the tapering threaded tip 325 and a  
25 lumen 323 extending between a proximal end 318a and a distal end 319a of dilating catheter 324. The guidewire 311 is insertable through the lumen 323 so that the dilating catheter may be inserted over the guidewire along an access path, which may be an arcuate path, and through one or more walls of the heart as described herein. Figs. 10A and 10E show a detail view of the tapering threaded tip 325. The threads contact, grip, and/or cut tissue of the heart wall as the  
30 dilating catheter 324 is rotated and inserted through the wall. This minimizes the axial forces exerted against the heart wall, which may reduce arrhythmia and other conditions of the heart

resulting from such axial stress. In some instances, the heart wall (e.g., septum SE and/or external wall EW) comprises tough scar tissue, which may be difficult to penetrate.

Figs. 10 and 10F show aspects of the pusher tube 336 and loading cartridge 334. Fig. 10F shows the pusher tube 336 having 4 lumens, which include the guidewire lumen 339, through which  
5 guidewire 311 is inserted, and tether lumen 341, through which tether 333 is inserted. Guidewire 311 may be inserted within guidewire lumen 339 at a distal end 319b of pusher tube 336 and exit pusher tube 336 via guidewire port 343 at a proximal end 318b. Similarly, as shown in Fig. 10, tether 333 may be inserted within tether lumen 341 at distal end 319b and exit pusher tube 336 via tether port 345 at proximal end 318b. Loading cartridge 334 may be coupled with pusher  
10 tube 336 at distal end 319b and inserted within lumen 317 of delivery catheter 326.

Figs. 10, 10D, and 10E show aspects of septal anchor 332, epicardial anchor 355, anchor set tool 359, and tether 333. Specifically, the figures show septal anchor 332 coupled with tether 333 at pivot point 333a. The figures also show epicardial anchor 355 with lumen 353 through which tether 333 is inserted as shown in Fig. 10E. Fig. 10D shows epicardial anchor 355 disconnected  
15 from anchor set tool 359. Fig. 10D also shows sheath 371, retractable post 367, and hooks 368 of anchor set tool 359 and shows outer layer 362, housing surface 366, lumen 353, and arms 364 of epicardial anchor 355. As described previously, hooks 368 are used to grip arms 364 and post 367 contacts housing surface 366 to actuate cam 363 upon actuation of rotatable cap 357 and thereby configure epicardial anchor 355 in either a variable force mode or a set force mode. As  
20 shown in Fig. 10E, epicardial anchor 355 is slidable along the length of tether 333 when epicardial anchor is in the variable force mode. When epicardial anchor is in the set force mode, epicardial anchor 355 may be slid toward septal anchor 332, but not away therefrom.

Fig. 10 also shows force application tool 314 having an elongate shaft 316, force spring 313, and indicia 315 as described previously. Indicia 315 may include a series of marks spaced along  
25 elongate shaft 316. Force spring 313 and indicia 315 are housed within main body 307, which may be made of a clear material so that indicia 315 is visible from outside main body 307. Force application tool 314 includes a lumen 309 that extends between a proximal end 318c and a distal end 319c through which tether 333 is inserted. Force application tool 314 applies a force against epicardial anchor 355 as tether 333 is tensioned from proximal end 318c and main body 307 is  
30 pushed toward epicardial anchor 355.

Referring now to Figs. 10B and 10C, shown is another embodiment of a pusher tube 1036, which may be inserted through lumen 317 of delivery catheter 326. Similar to pusher tube 336, pusher tube 1036 includes four lumens. Guidewire lumen 1039 is a lumen through which guidewire 311 may be inserted. Guidewire lumen 1039 extends from distal end 1019 to guidewire port 1043 at proximal end 1018. Similarly, tether lumen 1041 is a lumen through which tether 333 may be inserted. Tether lumen 1041 extends from distal end 1019 to tether port 1045 at proximal end 1018. Pusher tube 1036 also includes a pair of opposed deployable arms 1031, which are housed within lumens 1052 and deployable axially and laterally therefrom. Deployable arms 1031 may be deployed so that the arms radially extend from pusher tube 1036. Deployable arms 1031 may then be engaged against an interior surface of one of the heart walls to stabilize pusher tube 1036 and/or delivery catheter 326 and facilitate in deployment of septal anchor 332 and/or epicardial anchor 335. In some embodiments, pusher tube 1036 includes a malecot and/or balloon, which provides a similar function to deployable arms 1031. Further, in some embodiments, deployable arms comprise nitinol springs and are deployable from lumens 1052 or retractable within lumens 1052 upon rotation of main body 1050 or upon operation of an actuation device located at proximal end 1018.

Referring now to Figs. 11A – 11C, shown is another embodiment of a delivery catheter 1126. Delivery catheter 1126 may replace the separate delivery catheter 326 and pusher tube 336 by combining these tools into one tool. Delivery catheter 1126 may include a catheter body 1142 having a tapered distal tip 1124 at distal end 1119 and a sheath 1145 disposed over catheter body 1142 proximally of tapered distal tip 1124. Sheath 1145 may be proximally retractable relative to catheter body 1142 to expose anchor receptacle 1144, which houses septal anchor 332. Anchor receptacle 1144 may be coupled with tether port 1143 at proximal end 1118 so that tether 333 extends along the length of catheter body 1142 from proximal end 1118 to anchor receptacle 1144. Catheter body 1142 may include a guidewire lumen through which guidewire 311 may be inserted. The guidewire lumen may extend along catheter body 1142 and couple with guidewire port 1145 through which guidewire 311 exits delivery catheter 1126. Sheath 1145 may include a stop 1160 which limits proximal retraction of sheath 1145 by contacting main body 1150. In some embodiments, stop 1150 is positioned adjacent external wall EW and catheter body 1142 is advanced distally to expose anchor receptacle 1144.

Septal anchor 332 may be laterally deployable from anchor receptacle 1144 as shown in Fig. 11C. Catheter body 1142 may include a sloped deployment member 1170 that facilitates in

lateral deployment of septal anchor 332 from anchor receptacle 1144 as septal anchor 332 is distally advanced relative to delivery catheter 1126.

Operation of delivery catheter 1126 is similar to delivery catheter 326 described in Figs. 3A – 30 in that guidewire 311 is inserted through external wall EW and septum SE into right ventricle RV and delivery catheter 1126 is inserted over guidewire 311 into right ventricle RV. One difference is that septal anchor 332 need not include a lumen through which guidewire 311 is inserted since septal anchor 332 is housed within anchor receptacle 1144 and inserted into right ventricle RV while housed within anchor receptacle 1144. Tapered distal tip 1124 dilates the aperture through external wall EW and/or septum SE as delivery catheter is inserted through the respective wall. Although not shown, tapered distal tip 1124 may be threaded as described herein. After distal end 1119 of delivery catheter 1126 is positioned within right ventricle RV, sheath 1145 is proximally retracted (or catheter body is distally advanced) exposing anchor receptacle 1144. Septal anchor 332 is then laterally deployed from anchor receptacle 1144 via deployment member 1170 by distally advancing septal anchor 332 relative to catheter body 1142. With septal anchor 332 deployed within right ventricle RV, delivery catheter 1126 may be removed and epicardial anchor 355 secured to tether 333 as described herein to limit the volume of left ventricle LV. In some embodiments, delivery catheter 1126 may comprise a flexible material to allow delivery catheter 1126 to follow an arcuate epicardial access path defined by guidewire 311.

Referring now to Fig. 4A, joining of an access path through the right atrium to an access path through the pericardium and epicardium by snaring of a guidewire within the right ventricle under thoroscopic guidance 20 is schematically illustrated. The right atrial access path may extend into the arterial vasculature via the femoral artery FA and inferior vena cava IVC, via the jugular artery JA via the superior vena cava SVC, or the like. As can be understood with reference to Fig. 4B, a selected location for perforation of the external wall EW can be identified using an image from thoracoscope 20, optionally in combination with an image from another imaging modality (such as a prior or contemporaneous image from an ultrasound imaging system, an MRI imaging system, an X-ray or fluoroscopic imaging system, a CT imaging system, or the like). In exemplary embodiments, a rigid or semi-rigid shaft of an access tool 22 having a working lumen therethrough is advanced through the epicardium of the beating heart so that a distal end of the shaft is disposed within the left ventricle LV. Access tool 22 may comprise a relatively simple needle or trocar, and may have a proximal hemostasis valve at its

proximal end so as to inhibit bloodflow through the lumen and facilitate insertion and/or removal of a guidewire and the like. In some embodiments, access tool 22 may have a tissue penetrating sharpened distal end to facilitate distal insertion, and/or a stylus may be removably disposed within the lumen. Optional embodiments of access tool 22 may have an energy delivery surface at or near the distal end so as to deliver radiofrequency energy, laser energy, or the like to facilitate penetrating the tissue of the external wall EW. Suitable RF penetrating structures may be commercially available from (or modified from those available from) Baylis Medical of Toronto Canada.

Still referring to Fig. 4B, access tool 22 may optionally include a laterally deployable structure near the distal end so as to stabilize the access tool relative to the beating heart tissue around the left ventricle. Suitable deployable stabilizing structures may include a malecott, a pair of opposed deployable arms (optionally similar to those described below with reference to Figs. 10B and 10C), or the like. The laterally deployable distal structure may be configured for engagement against an interior surface of the left ventricle LV or against the epicardial surface of the left ventricle (such as by having the deployable structure spaced proximally of the distal end). Regardless, once access tool 22 is disposed within the left ventricle, a catheter 24 may be advanced through the working lumen of access tool 22, into the left ventricle, and through a target location of the septum S. A guidewire 26 will also be inserted through the left ventricle and septum as shown. A variety of structures and techniques can be used for perforating the septum, with the catheter optionally being used to penetrate the septum in some embodiments, with the catheter optionally having a sharpened end, a removable stylus, an energy delivery surface, or the like. When catheter 24 perforates the septum, the catheter will often have steering capabilities so as to facilitate perforation at a target location, though in some embodiments catheter 24 may be steered using steering capabilities of the guidewire within the working lumen, a steering catheter extending around the catheter and through the working lumen of access tool 22, or the like. In other embodiments, guidewire 26 may be used to perforate through the septum, with the guidewire optionally having an energy delivery tip and/or steering capabilities, with the catheter being advanced through the septum over the guidewire. Exemplary steerable guidewires with RF penetrating tips include those commercially available from (or may be derived from those available from) Baylis Medical of Toronto Canada.

A wide variety of alternative septum perforation approaches might be employed, including using atrial septum perforation structures and techniques (or structures and techniques derived

therefrom). For example, mechanical systems may employ a sharpened distal tip and axial penetration (such as using structures commercially available from – or structures derived from the SafeSept<sup>tm</sup> transseptal guidewire commercially available from Adaptive Surgical, LLC; the Across Transseptal Access System commercially available from StJude, or the like, a rotatable  
5 angled blade, the transseptal puncturing structures and methods described by Wittkamp et al, in US2011/0087261, or the like. RF systems may employ a proprietary tissue penetrating structure or may energize an off-the-shelf transseptal needle with RF energy, as was described by Knecht et al. in an article entitled “Radiofrequency Puncture of the Fossa Ovalis for Resistant  
10 Transseptal Access,” Circ Arrhythm Electrophysiol 1, 169 (2008). Laser-energy transseptal approaches may also be employed, including structures commercially available from (or derived from those commercially available from) Spectranetics and others.

Once catheter 24 is advanced through the septum, the working lumen of the catheter may be used to access the right ventricle from outside the patient, with the guidewire optionally being removed and replaced (particularly when the guidewire has been used to perforate the septum)  
15 with another guidewire, or remaining for use in joining the access paths. To facilitate use of catheter 24 as a right ventricle access tool and swapping guidewires or the like, a hemostasis valve may be provided at a proximal end of the catheter.

Referring now to Figs 4C – 4E, a distal end of catheter 30 may be advanced to the right ventricle RV through the right atrium RA and associated vasculature using known techniques, so that  
20 catheter 30 provides a right ventricle access tool. Optionally, a snare tool has a distal portion configured to engage a distal portion of the guidewire. For example, distal snare 32 may be separated from a proximal end of a snare body by sufficient length of the snare body to allow the snare to be manipulated within the right ventricle from the proximal end of catheter 30. Snare 32 may be biased to open when advanced beyond catheter 30, allowing the catheter to be positioned  
25 near the septum around the epicardial path of catheter 24. Advancing guidewire 26 through the opening of snare 32 and withdrawing snare 32 into catheter 30 so that the guidewire is bent as it enters the distal end of catheter 30 axially couples the guidewire to the snare.

Referring now to Figs 5A and 5B, there may be advantages to employing alternative elongate flexible bodies to couple the access paths within the heart. For example, a guidewire-like  
30 elongate body with a proximal end and a distal portion formed as a basket 34 may be expanded in the right ventricle so that the basket encompasses a volume within the right ventricle. In some

embodiments, the basket may be withdrawn back into catheter 24 or 30 so as to capture a guidewire extending from the other, thereby joining the paths. In other embodiments, a guidewire-like elongate flexible body 36 having short lateral distal protrusion or barb can be advanced a relatively short distance into a target portion of the basket and withdrawn back into the catheter so as to capture a member of basket 34, with the target portion of the basket being separated from sensitive heart tissues (such as valve leaflets or chordae) by the expansion of the basket. Optionally, the basket 34 may be advanced toward or into the right atrium before engaging the basket with the distal portion of flexible body 36. An exemplary basket structure and associated access catheter are shown in Fig. 6.

Referring now to Fig. 7, still alternative distal end portions may be used to help couple the flexible bodies advanced into the heart via the right atrial and epicardial access paths. In this embodiment, catheter 30 is advanced through the right atrium and the right ventricle to the pulmonary artery PA. Snare 32 is expanded in the pulmonary artery PA. A distal balloon 40 mounted to a flexible tubular body 38 is advanced through catheter 24 into the right ventricle. Balloon 40 is inflated from a distal end of the flexible body 38 via an inflation lumen of the flexible body, and the balloon is allowed to flow with the blood of the heart into a pulmonary artery PA. The balloon is captured by the snare. Note that the access catheter 24, 30 associated with the various flexible bodies described above may be switched, so that (for example) balloon 40 may be advanced through catheter 30 along the right atrial access path, while snare 32 may be advanced along catheter 24 along the epicardial approach. Regardless of the specific end portions of the flexible bodies employed to axially couple the flexible bodies, coupling of the pathways allows guidewire 26 to be inserted into the body along one of the paths and withdrawn out of the body from along the other path so that both a first end 42 and a second end 44 of the guidewire are disposed outside the heart and the patient. The result is the guidewire extending from a first end disposed outside the patient, into the right ventricle of the heart along the epicardial access path, and back out of the heart and the patient through the left ventricle along the epicardial access path, as shown in Fig. 8.

Referring now to Fig. 9, once guidewire 26 extends from the first end, into the right ventricle along the epicardial access path, and back out the heart and patient through the left ventricle along the epicardial access path, septal anchor 32 and tether 33 may be advanced over guidewire 26 into right ventricle RV and/or adjacent septum SE. Tether 33 may be advanced over guidewire 26 as shown in Figs. 13A – 14C and may be advanced ahead of septal anchor 32 so

that tether 33 extends from adjacent septum SE, through left ventricle LV, to outside the patient body as shown in Fig. 9. Guidewire 26 may then be removed so that septal anchor 32 may rotate relative to tether 33 as described herein. Epicardial anchor 35 may then be coupled with tether 33 and advanced adjacent external wall EW, a force may be applied between epicardial anchor 35 and tether 33, and epicardial anchor 35 may be secured relative to tether 33 and septal anchor 32 as described herein.

Referring now to Figs. 13A – 14C, alternative embodiments of the systems may be configured to deliver septal anchor 32 to the right atrium along the right atrial path, typically with septal anchor 32 trailing behind tether 33. An end of tether 16 is generally disposed opposite of anchor 32, and may include features to maintain the tether in alignment along the guidewire, and may also axially couple the tether to the guidewire. For example, a channel such as angled channel, 64a or 64b, may receive the guidewire 31 therein, allowing the tether to be pushed axially over the guidewire. One or more additional channels 66 (shown in Fig. 13C) through tether 33 toward anchor 32 may help limit bowing of the tether 33 away from guidewire 31 when tether 33 is pushed axially over guidewire 31. As can be understood with reference to Figs. 14A – 14C, end 70 of tether 33 is advanced over guidewire 31 and into a proximal hemostasis valve 29 of catheter 30. By continuing to push tether 33 into catheter 30, and/or by pulling guidewire 31 from the end extending from the epicardial path, end 70 of tether 33 may be advanced into and through the septum SE and external wall EW so that end 70 is disposed outside the heart and the patient. Optionally, tether 33 may be advanced along the epicardial path alongside guidewire 31. In other embodiments, catheter 30 or another catheter body may be advanced over the guidewire with tether 33 disposed in a lumen.

Referring now to Figs. 16A – 16F, an epicardial access tool 1600 may facilitate both access to the epicardium and hemostasis of the epicardial access path. A shaft 1606 of the epicardial access tool 1600 extends from a proximal actuation device 1612 (i.e., handle 1610) to a circumferential series of distal radial compression features or tines 1602. Compression features or tines 1602 function as a gripper device that grips or releasably attaches with the epicardial surface of the heart. A working lumen of the access tool shaft 1606 allows the various access tools to be advanced along a tissue tract from outside the patient to an epicardial surface region encompassing the epicardial access path. The compression features or tines 1602 are oriented to engage tissue of the external wall and urge the engaged tissue radially inwardly when the handle 1610 is actuated. In the exemplary embodiment, filaments or tension members 1604 extend



axially from the handle 1610 along the shaft 1606 to each compression feature 1602, and then turn laterally from that compression feature 1602 to another compression feature. Actuation of the handle 1610 pulls the filaments 1604, thereby pulling the compression features 1602 radially inwardly. The actuation device 1612 may include a ratchet mechanism 1620 within a main

5 body. Handle 1610 may operate the ratchet device 1620 to pull or tension filaments 1604 and thereby pull compression features 1602 radially inward. Figs. 16B and 16C show the compression features 1602 or tines extending from shaft 1606 and being inserted within epicardial tissue 1650 of the heart. Filaments 1604 are attached with the compression features 1602 to pull the compression features radially inwardly as shown by the arrows in Fig. 16C.

10 Fig. 16E shows an alternative embodiment of the epicardial access tool 1600. In this embodiment, an outer shaft 1630 is slidably positioned over the compression features 1602 and shaft 1606. Handle 1610 is actuated to distally advance outer shaft 1630 over compression features 1602. A radially directed inward force is imparted to compression features 1602 as outer shaft 1630 advances over the compression features. Compression features 1602 direct the

15 radially directed inward force to the epicardial tissue of the heart, thereby providing hemostasis to one or more devices inserted through the working lumen of shaft 1606. Proximal actuation device 1612 may have a release mechanism 1624 that allows outer shaft 1630 to be proximally retracted and/or release tension from filaments 1604 to thereby relieve the inwardly directed force applied to compression features 1602.

20 Figs. 20 – 22, shows an alternative embodiment of an epicardial access tool employing suction to grip and stabilize the epicardial surface of the heart, somewhat analogous to the engagement between known heart stabilization tools and the heart as used for beating-heart coronary arterial bypass grafting and the like. Epicardial access tool 2000 has a large suction pad 2010 disposed at a distal end of cannula or shaft 2002 having a working lumen 2008 there through. In this

25 embodiment, suction pad 2010 functions as a gripper device to grip the epicardial tissue of the heart. An intracardiac device (not shown) may be inserted through the working lumen 2008 to perform a medical procedure within a chamber of the heart (not shown). Suction pad 2010 is made of a resilient material that allows suction pad 2010 to be pressed against and engage the epicardial tissue of the heart. Suction pad 2010 includes a plurality of suction ports 2014 that are

30 in fluid communication with a suction lumen and suction device disposed outside the patient body. Suction is applied to the suction ports 2014 to affix the suction pad 2010 and shaft 2002

about an access site for an intracardiac device and thereby stabilize the heart and/or provide hemostasis.

Figs. 21 and 22 show other embodiments of epicardial access tools, 2100 and 2200, employing suction to grip and stabilize the epicardial surface of the heart suction device. Epicardial access tool 2100 includes an arcuate suction channel or chamber 2104. Arcuate suction channel 2104 is in fluid communication with suction lumen 2102, which may be coupled with a suction device disposed external to the patient body. Disposed on a bottom surface 2108 of arcuate suction channel 2104 and in fluid communication therewith is a plurality of suction ports 2120 that grip or affix to the epicardial tissue of the heart upon application of suction via suction lumen 2102.

10 In this embodiment, suction ports 2120 function as a gripper device to grip, grasp, or otherwise affix to the epicardial tissue of the heart. Arcuate suction channel 2104 also includes an access slot 2130 that extends radially outward from a centrally located aperture 2110. The access slot 2130 allows epicardial access tool 2100 to be inserted over a shaft, such as the shaft delivery catheter 326 and/or 1026, shaft 2002, and the like. Aperture 2110 may be shaped and sized to

15 correspond with an outer diameter of such a shaft and may couple epicardial access tool 2100 to the shaft. Aperture 2110 may be fitted about the shaft and couple the shaft by an interference fit. In some embodiments, the opposing ends 2114 of arcuate suction channel 2104 adjacent access slot 2130 may be circumferentially moved or adjusted, thus, allowing arcuate suction channel 2104 to contract about the shaft and/or an intracardiac access tool penetrating through the

20 epicardium. Arcuate suction channel 2104 may apply or otherwise provide a force directed radially toward aperture 2110 to the epicardial tissue to stabilize the heart and/or provide hemostasis to the intracardiac device. Such radially directed inward force (i.e., circumferential movement of opposing ends 2114) may be effected upon actuation of a proximally located actuation mechanism coupled with epicardial access tool 2100, such as handle 1610.

25 The epicardial access tool 2200 shown in Fig. 22 is similar to epicardial access tool 2100 in that epicardial access tool 2200 includes an arcuate suction channel 2204, a suction lumen 2202 in fluid communication with arcuate suction channel 2204, an access slot 2230, and centrally located aperture 2210. Epicardial access tool 2200 further includes a plurality of suction pads 2240 spaced circumferentially around arcuate suction channel 2204 and aperture 2210. Each

30 suction pad 2240 includes a centrally positioned suction port 2220 that is in fluid communication with fluid lumen 2202 and a suction device disposed external to the patient body. Suction pads 2240 are made of a resilient material that allows the suction pads to be pressed against and

engage the epicardial tissue of the heart. Suction pads 2240 grip, grasp, or otherwise affix to the epicardial tissue of the heart upon application of suction via suction lumen 2102. As described above, arcuate suction channel 2204 may be inserted over a shaft and coupled therewith by inserting shaft within aperture 2210. Likewise, as described above, opposing ends 2214 adjacent  
5 access slot 2230 may be circumferentially moved or adjusted allowing arcuate suction channel 2204 to contract about the shaft and/or an intracardiac access tool penetrating through the epicardium, or otherwise provide a radially inward directed force. The radially directed inward force may be effected upon actuation of a proximally located actuation mechanism as described herein.

10 In some embodiments, the epicardial access tool is applied to the epicardium with the gripper device (i.e., tines 1602, suction pads 2010 and/or 2040, suction ports 2120, and the like) fixed in an expanded configuration. After the gripper device is secured to the epicardium, the gripper device may be released from the expanded configuration so that the gripper device exerts a radially inward directed force on the epicardial tissue and thereby stabilizes or provides  
15 hemostasis to an intracardiac device inserted through the epicardium.

Referring now to Figs. 19A-19D, a variety of minimally alternative anchor locking structures and access methods may be employed to decrease collateral tissue trauma when applying the controlled anchoring force. Such minimally invasive anchor locks may benefit from a tissue-engagement component that distributes anchoring loads laterally between anchors so as to  
20 promote apposition of the walls of the heart along a desired contour and help provide the desired ventricular shape after implantation of a multi-anchor implant system. Toward that end, a folding anchor component 1911 may comprise an at least substantially rigid elongate body having a passage traversing therethrough, with a channel extending along opposing surfaces of the body from the aperture. One of the channels may optionally extend through the body,  
25 allowing the body to be advanced laterally over tether 1916 so that the tether extends through the body at the passage. Other embodiments may employ passages in the form of apertures, so that the tether 1916 is passed axially through the passage. Regardless, the channels receive the tether 1916 so that the anchor component 1911 can pivot toward axial alignment with tether 1916, allowing the anchor component to be advanced over tether 1916 through a working lumen of an  
30 access tool or sheath 1913, as shown in Fig. 19B. Once anchor component 1911 is distal of sheath 1913 and proximal of the epicardial surface of the heart H, the anchor component 1911 can be pivoted relative to tether 1916 and slid distally along tether 1916 into engagement with

the epicardial surface of heart H, as shown in Figs. 19C and 19D. A relatively small profile (as compared to the pivoted anchor component 1911) locking anchor component, such as epicardial anchor 355, can then be advanced axially over tether 1916 through sheath 1913 and into engagement with the anchor component 1911 so as to provide the desired anchoring force.

- 5 Anchor component 1911 may comprise a metal or high-strength polymer structure, such as a stainless steel, a Nitinol shape memory alloy, PEEK, or the like.

While the exemplary embodiments have been described in some detail for clarity of understanding and by way of example, a variety of modification, adaptations, and changes will be obvious to those of skill in the art. Hence, the scope of the present invention is limited solely  
10 by the appended claims.

WHAT IS CLAIMED IS:

1. A system for engaging epicardial tissue of a patient's heart, the system comprising:

an elongate tool body extending between a proximal end and a distal end, the  
5 elongate tool body being insertable through a body wall of the patient and the elongate tool body having a working lumen through which an intracardiac device is inserted to perform a medical procedure within a chamber of the heart; and

a gripping device near the distal end of the elongate tool body and operable  
10 therewith, the gripping device being disposed radially outwardly of the working lumen and being configured to be releasably attached to the epicardial tissue of the heart around the working lumen and an access site of the intracardiac device when performing the medical procedure within the chamber;

wherein the gripping device is coupled with an actuator that is articulatable from  
15 outside the patient body so as to move the gripping device radially inwardly toward an axis of the elongate tool body so as to facilitate stabilizing or hemostasis of the heart about the intracardiac device.

2. The system of claim 1, wherein the gripping device comprises a suction device.

3. The system of claim 2, wherein the suction device comprises a suction pad  
20 at the distal end of the elongate tool body, the suction pad comprising a plurality of suction ports in fluid communication with a suction lumen.

4. The system of claim 2, wherein the suction device comprises an arcuate  
25 suction channel, the arcuate suction channel having a plurality of suction ports positioned on a bottom surface that contact the epicardial tissue, wherein the suction ports releasably attach the gripping device to the epicardial tissue via suction through the suction ports.

5. The system of claim 4, wherein at least one of the suction ports comprises  
a suction pad comprising a resilient material that allows the suction pad to be pressed against and engage the epicardial tissue, the suction port being positioned toward a center of the suction pad.

6. The system of claim 4, wherein the arcuate suction channel comprises a radially extending slot that allows the arcuate suction channel to be inserted over the elongate tool body by inserting the elongate tool body through the slot.

7. The system of claim 6, wherein opposing ends of the arcuate suction channel adjacent the slot are movable circumferentially upon operation of an actuation mechanism to apply a contracting force to the epicardial tissue engaged by the arcuate suction channel so as to facilitate stabilizing or hemostasis of the heart about the intracardiac device.

8. The system of claim 6, wherein the arcuate suction channel is configured to radially contract upon operation of an actuation mechanism to apply a contracting force to the epicardial tissue engaged by the arcuate suction channel so as to facilitate stabilizing or hemostasis of the heart about the intracardiac device.

9. The system of claim 4, wherein the arcuate suction channel comprises an aperture shaped and sized to receive a couple with an outer surface of the elongate tool body.

10. The system of claim 1, wherein the gripping device comprises a plurality of elongate members coupled with the elongate tool body and extending radially outwardly from the distal end of the elongate tool body, the elongate members being engagable with the epicardial tissue to facilitate stabilizing or hemostasis of the heart about the intracardiac device.

11. The system of claim 10, wherein the plurality of elongate members are movable radially inwardly toward an axis of the elongate tool body upon operation of an actuator so as to provide a radially directed force to the epicardial tissue engaged by the plurality of elongate members.

12. The system of claim 11, further comprising a tension member coupled toward a distal end with each of the plurality of elongate members, the tension member being operable with the actuator to move the plurality of elongate members radially inwardly upon operation of the actuator.

13. The system of claim 11, further comprising an outer sheath disposed over the plurality of elongate members, the outer sheath being operable with the actuator to move the

plurality of elongate members radially inwardly upon operation of the actuator by distally advancing the outer sheath over the plurality of elongate members.

14. The system of claim 11, wherein the actuator comprises a handle that is grasped by a user's hand and a ratchet mechanism.

5 15. A tissue engagement device comprising:  
an arcuate suction channel having a plurality of suction ports configured to releasably engage epicardial tissue of a patient's heart via suction through the plurality of suction ports;

10 a suction lumen in fluid communication with the arcuate suction channel, the suction lumen being couplable with a suction device disposed external to the patient to provide suction to the arcuate suction channel; and

15 an access slot extending radially from a centrally located aperture, the access slot allowing the arcuate suction channel to be inserted over a cannula that facilitates in performing a medical procedure within a chamber of the patient's heart, wherein the centrally located aperture is shaped and sized to receive the cannula and be releasably secured thereto.

16. The tissue engagement device of claim 15, wherein the arcuate suction channel comprises a plurality of suction ports positioned on a bottom surface that engages the epicardial tissue, wherein the suction ports releasably affix the arcuate suction channel to the epicardial tissue via suction through the suction ports.

20 17. The tissue engagement device of claim 16, wherein at least one of the suction ports comprises a suction pad that is pressed against and engages with the epicardial tissue, the suction port being positioned toward a center of the suction pad.

25 18. The tissue engagement device of claim 15, wherein opposing ends of the arcuate suction channel adjacent the access slot are circumferentially movable upon operation of an actuation mechanism to apply a contracting force to the epicardial tissue engaged by the arcuate suction channel so as to stabilize a portion of the heart or apply hemostasis to one or more devices penetrating through an incision through the epicardial tissue.

19. A device for accessing tissue within a patient's heart, the device comprising:

an elongate tool body extending between a proximal end and a distal end, the elongate tool body being insertable through a body wall of the patient and the elongate tool body having a working lumen therethrough, the working lumen configured for receiving an intracardiac device to perform a medical procedure within a chamber of the heart; and

a plurality of grippers near the distal end of the elongate tool body and operable therewith, the grippers disposed radially outwardly of the working lumen and being configured to be releasably attached to the epicardial tissue of the heart around the working lumen and an access site of the intracardiac device when performing the medical procedure within the heart;

wherein the grippers are coupled to the elongate tool body by an actuator, the actuator being articulatable from outside the patient body so as to move the grippers radially inwardly toward an axis of the elongate tool body so as to facilitate hemostasis of the heart about the intracardiac device.

20. The device of claim 19, wherein the grippers comprise a plurality of elongate members, the elongate members being insertable within the epicardial tissue.

21. The device of claim 20, further comprising a tension member coupled near a distal end of each of the plurality of elongate members, the tension member being tensioned by the actuator to move the plurality of elongate members radially inwardly upon operation of the actuator.

22. The device of claim 20, further comprising an outer sheath disposed over the plurality of elongate members, the outer sheath being distally advanced over the plurality of elongate members upon operation of the actuator so as to move the plurality of elongate members radially inwardly.

23. The device of claim 21 or 22, wherein the actuator comprises a handle that is grasped by a user's hand and a ratchet mechanism.

24. A method for accessing tissue within a patient's heart, the method comprising:



providing an elongate tool body, the elongate tool body extending between a proximal end and a distal end and the elongate tool body comprising a working lumen extending between the proximal end and the distal end;

5 providing a gripping device, the gripping device being releasably attachable to the elongate tool body to facilitate in performing a medical procedure within a chamber of the heart;

positioning the elongate tool body through a body wall of the patient to adjacent the epicardial tissue of the heart;

10 inserting an intracardiac device through the working lumen and through the epicardial tissue of the heart at an access site so that a distal end of the intracardiac device is within the chamber;

releasably affixing the gripping device to the epicardial tissue of the heart so that the gripping device is disposed about the access site; and

contracting the gripping device so as to facilitate stabilizing or hemostasis of the heart about the intracardiac device.

15 25. The method of claim 24, wherein the gripping device comprises a plurality of elongate members that extend radially outwardly from the distal end of the elongate tool body, and wherein contracting the gripping device comprises moving the plurality of elongate members radially inwardly.

20 26. The method of claim 25, further comprising actuating an actuator to move the plurality of tines radially inwardly.

27. The method of claim 24, wherein the gripping device comprises a suction device releasably coupled with the elongate tool body near the distal end, and wherein releasably affixing the gripping device to the epicardial tissue comprises applying suction to the suction device.

25 28. The method of claim 27, wherein the suction device comprises:  
an arcuate suction chamber having a plurality of suction ports disposed on a bottom surface that engages with the epicardial tissue; and  
an access slot extending radially from a centrally located aperture;

and wherein the method further comprises inserting the elongate tool body within the access slot so that the centrally located aperture is releasably coupled about an outer surface of the elongate tool body.

29. The method of claim 28, wherein contracting the gripping device further  
5 comprises actuating an actuator to circumferentially move opposing ends of the arcuate suction chamber adjacent the access slot so as to apply a contracting force to the epicardial tissue engaged by the arcuate suction chamber.

30. The method of claim 24, wherein contracting the gripping device  
comprises:  
10 radially contracting the gripping device after the gripping device is affixed to the epicardial tissue of the heart; or  
radially expanding the gripping device; and  
releasably affixing the radially expanded gripping device to the epicardial  
tissue of the heart so that the gripping device contracts after being affixed to the  
15 epicardial tissue.

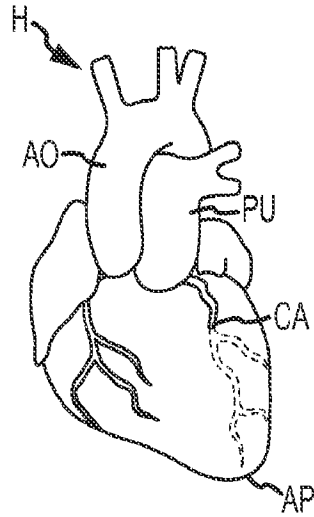

FIG. 1A

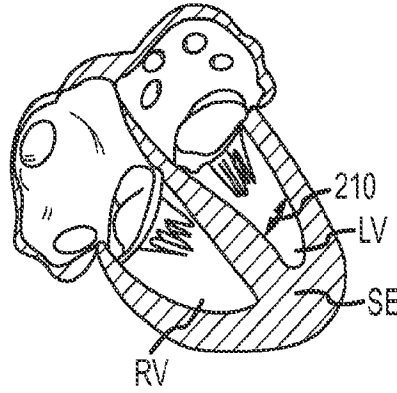

FIG. 1B

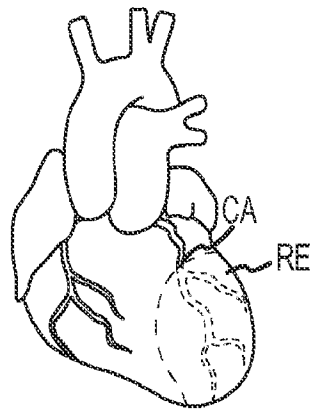

FIG. 1C

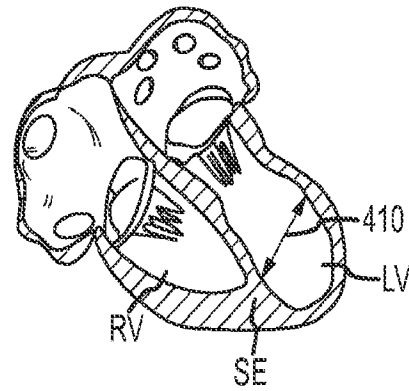
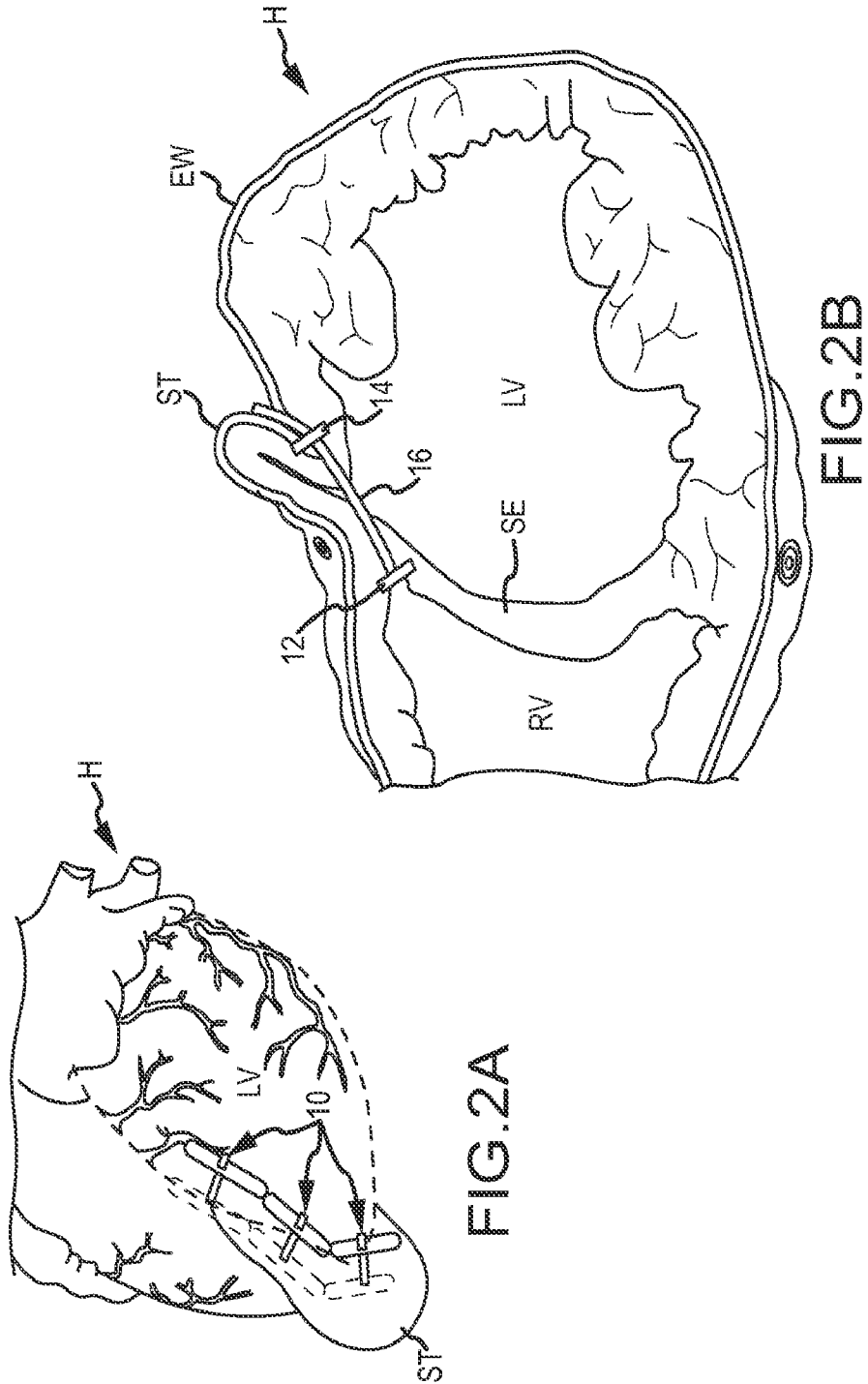

FIG. 1D



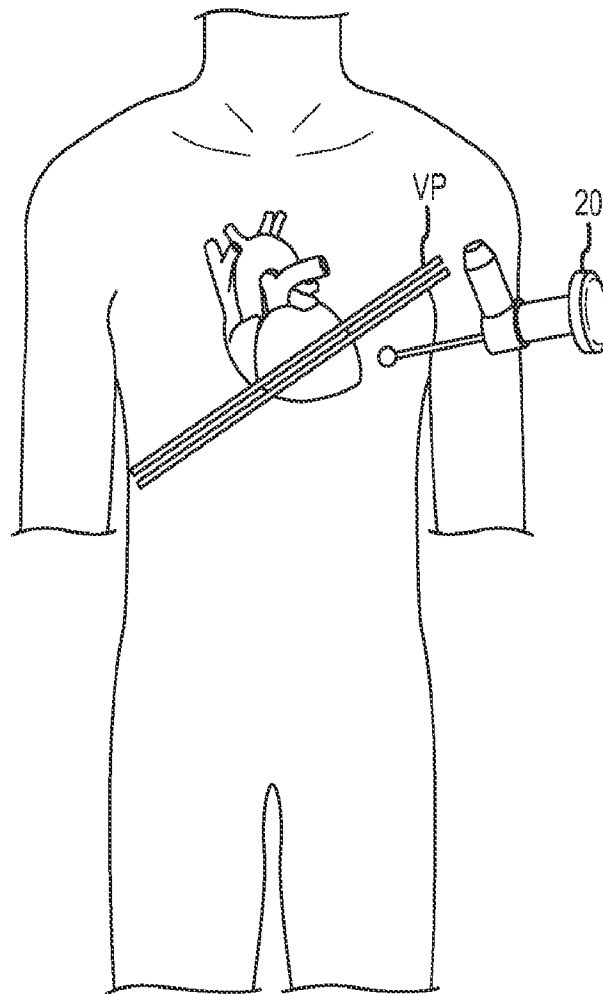

FIG.2C

4/44

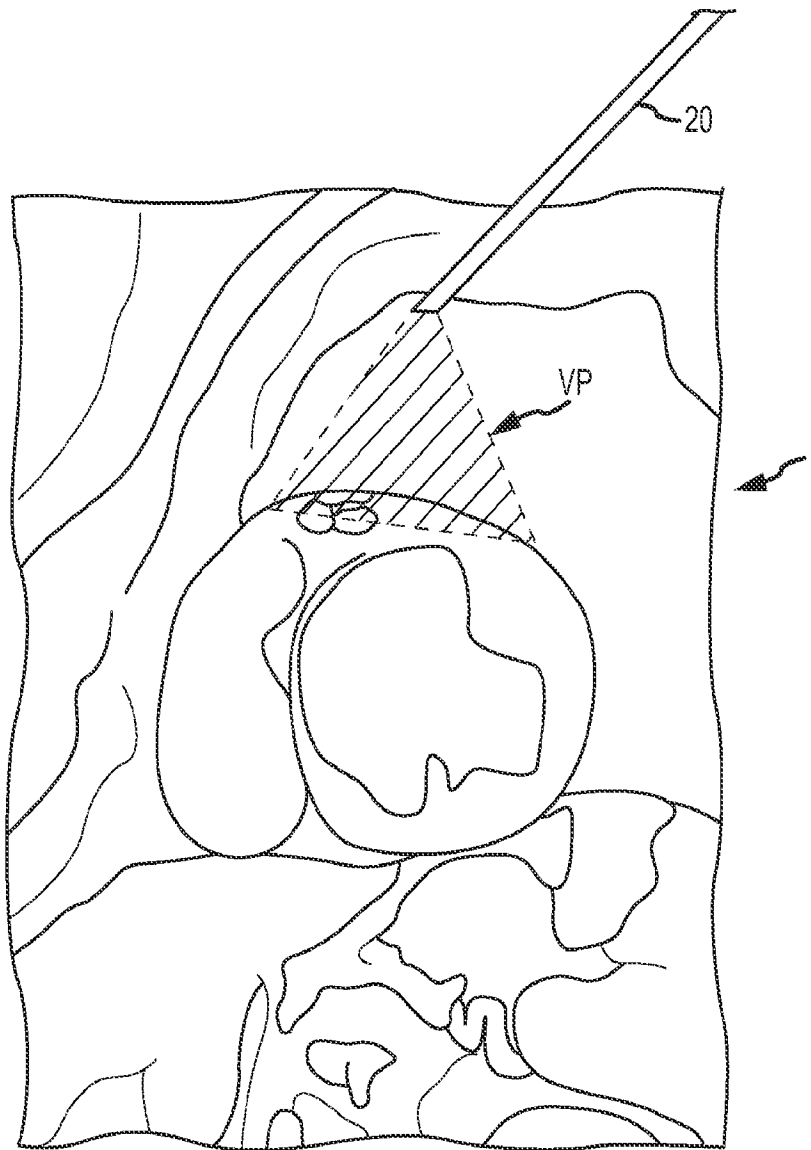

FIG. 2D

5/44

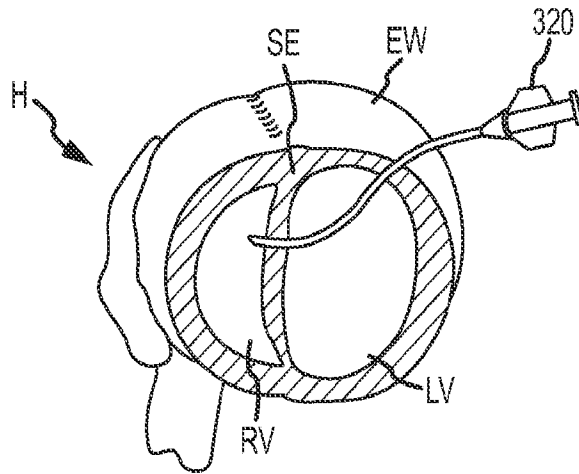

FIG. 3A

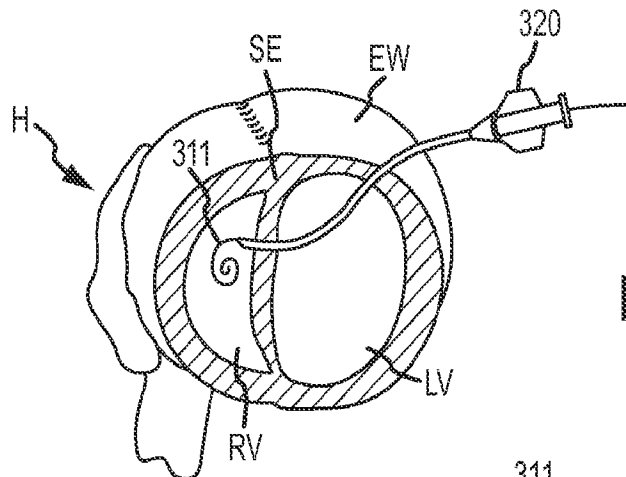

FIG. 3B

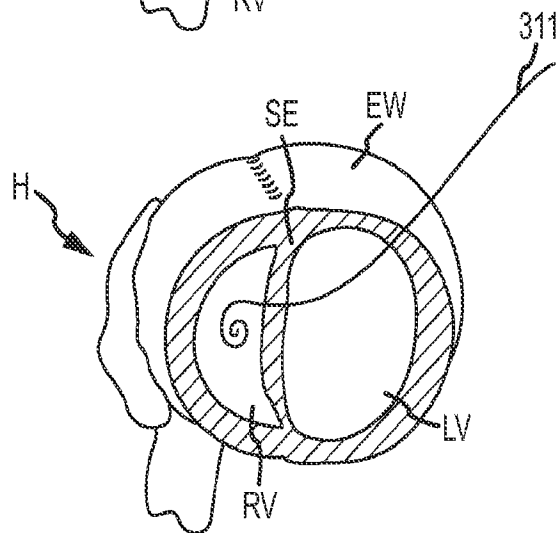

FIG. 3C

6/44

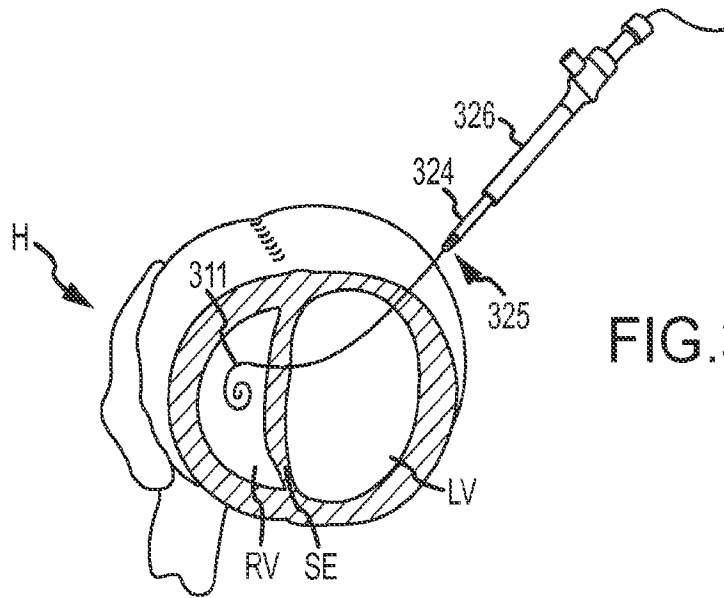

FIG. 3D

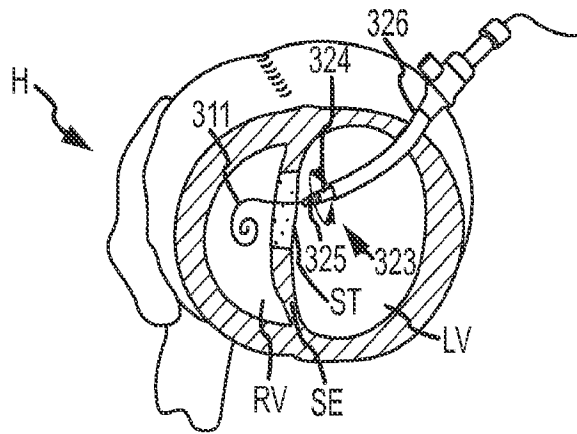

FIG. 3E



7/44

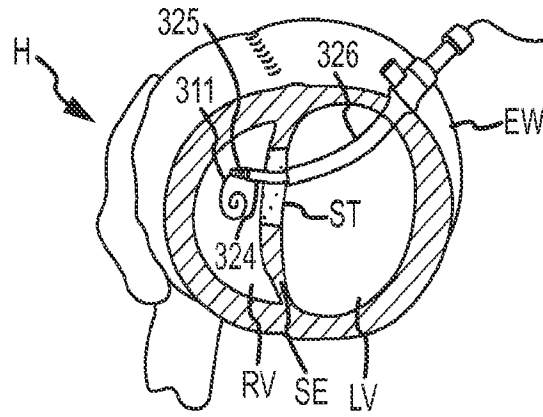

FIG. 3F

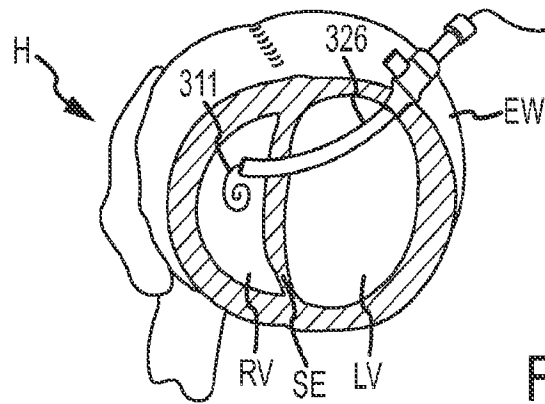

FIG. 3G

8/44

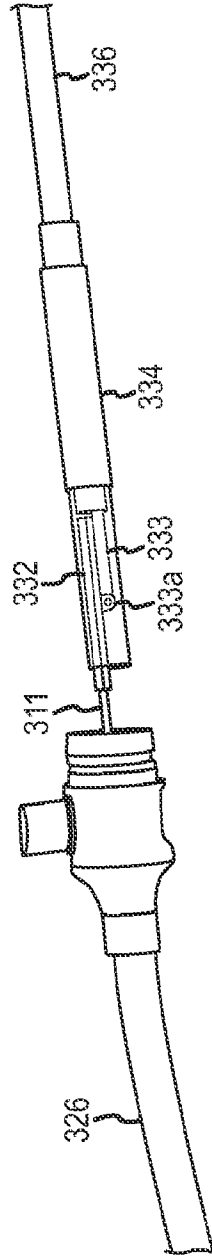

FIG.3H

9/44

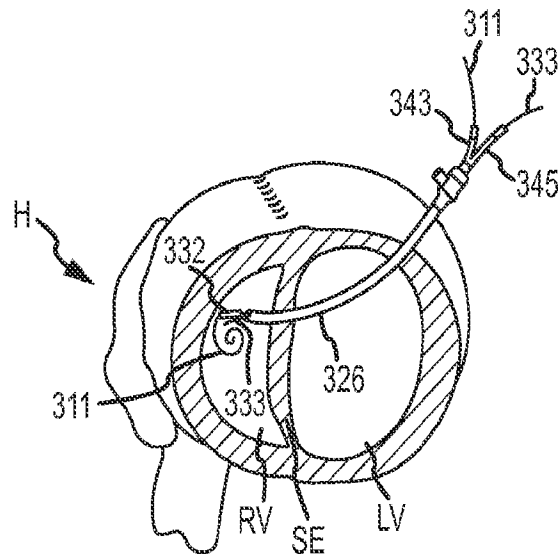

FIG. 3I

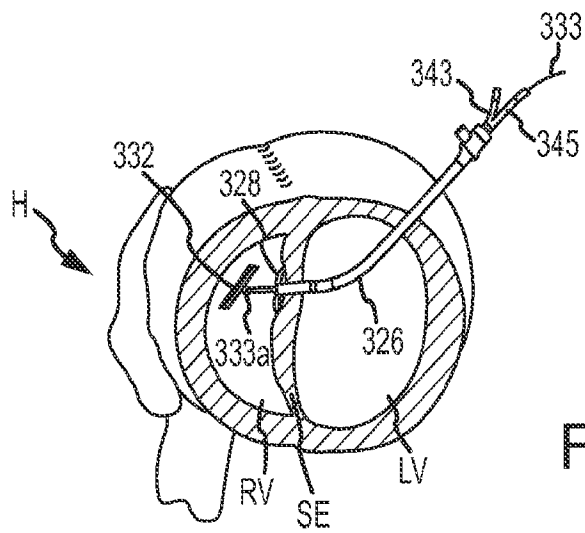

FIG. 3J

10/44

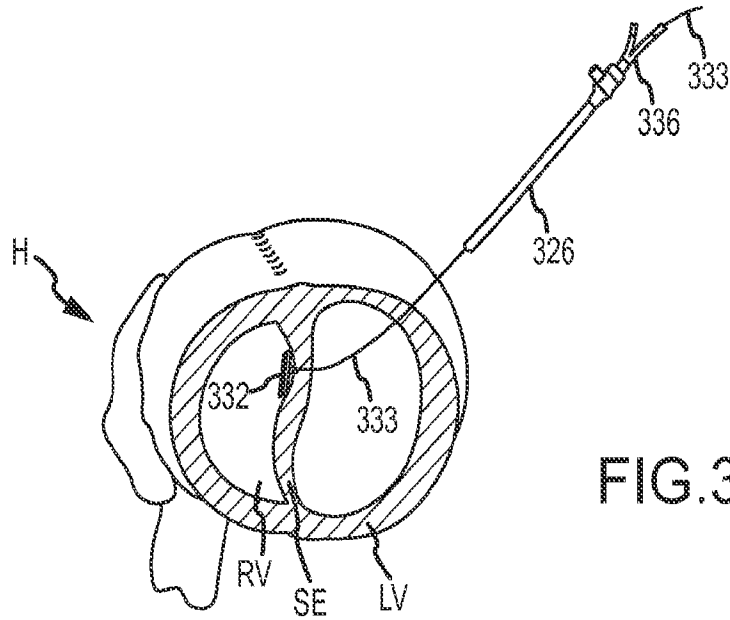

FIG. 3K

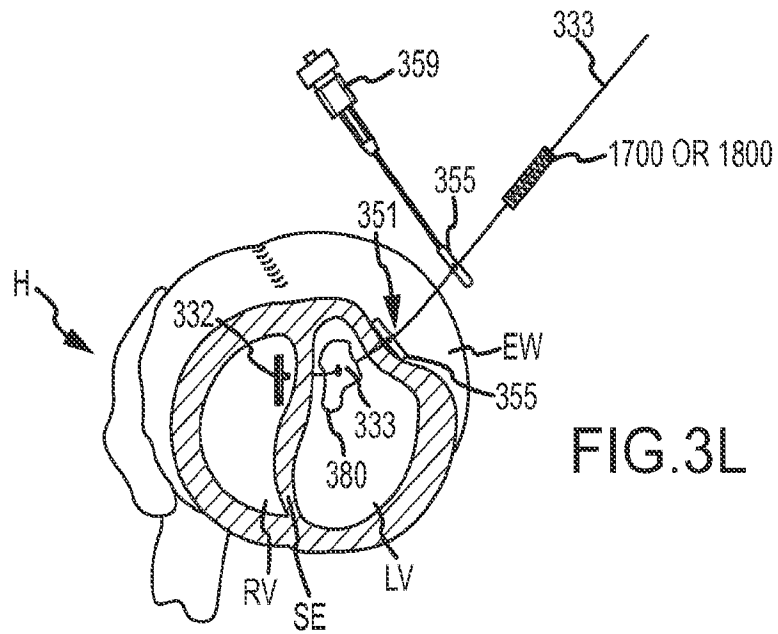
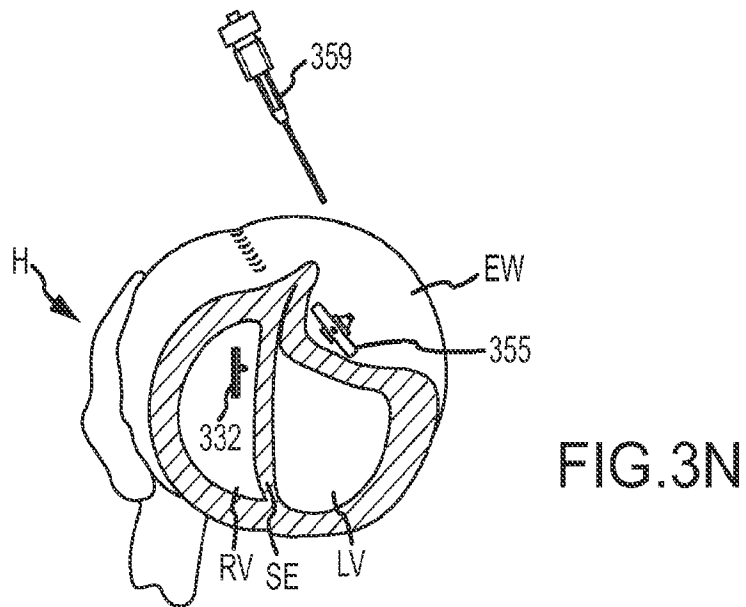
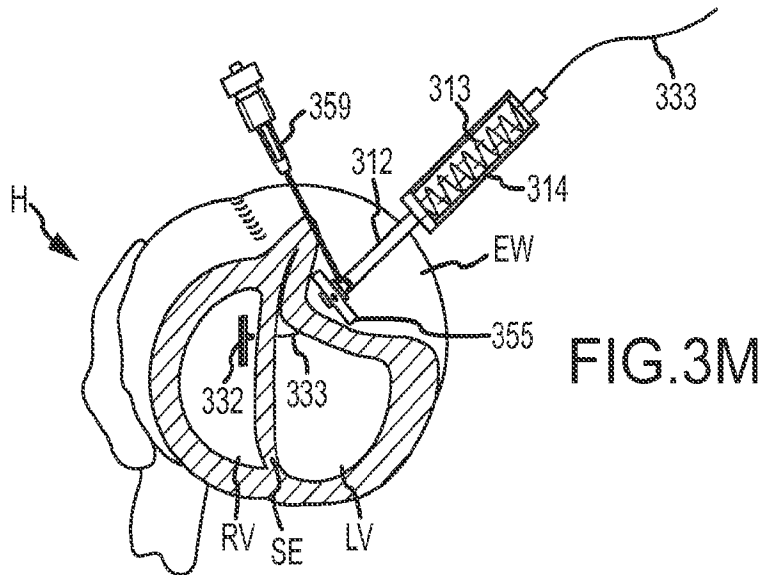

FIG. 3L

11/44



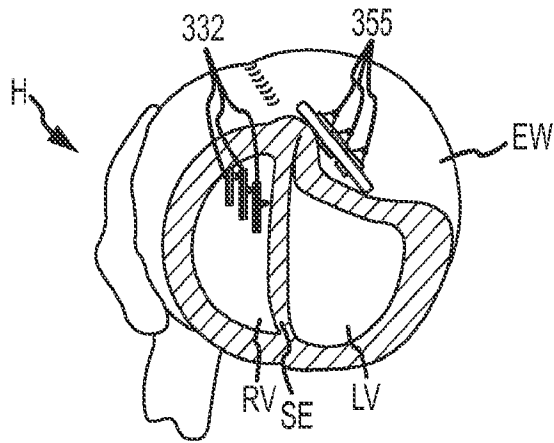

FIG.30

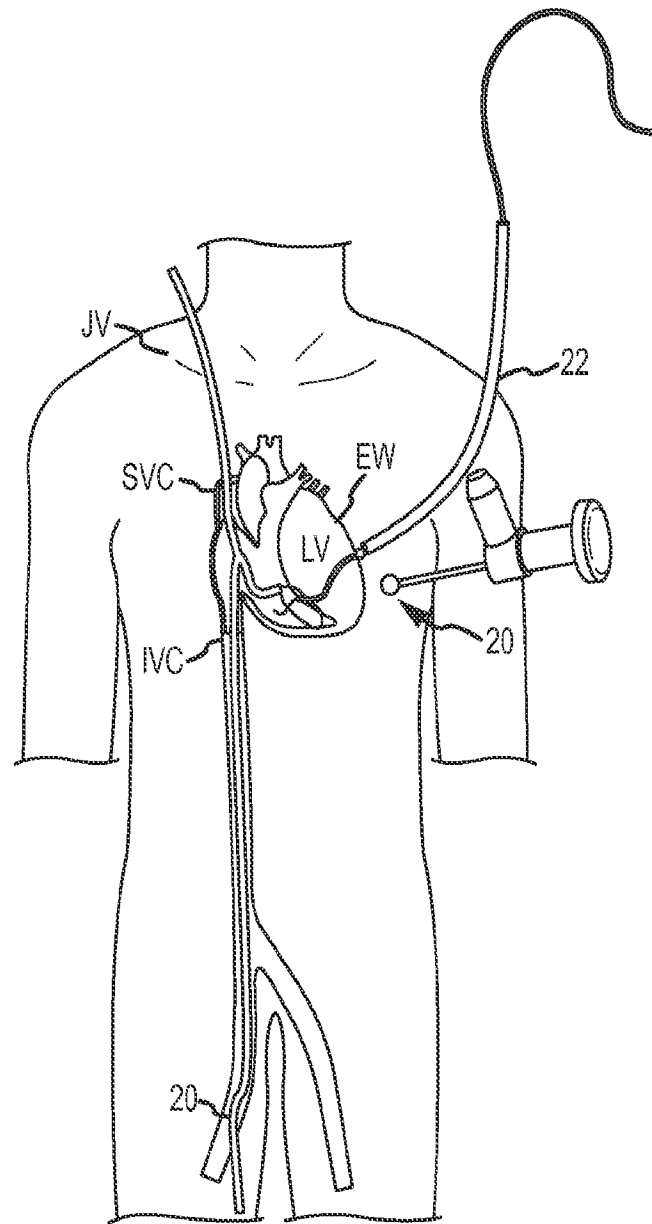

FIG.4A

14/44

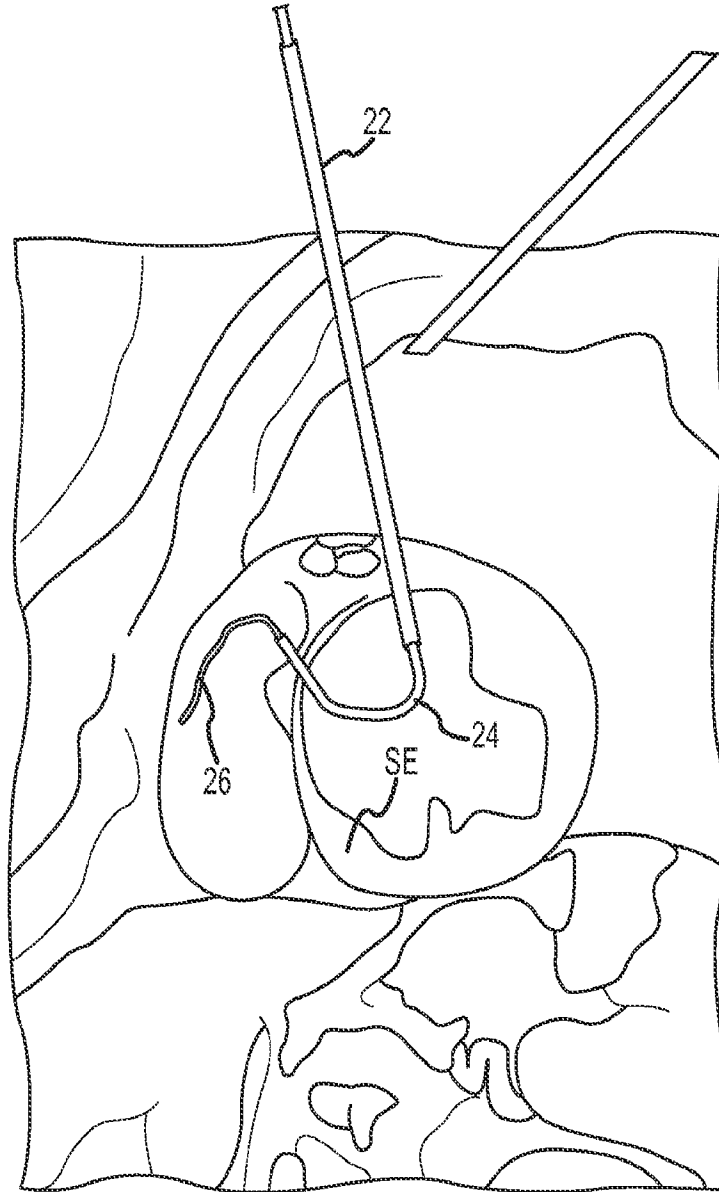

FIG.4B



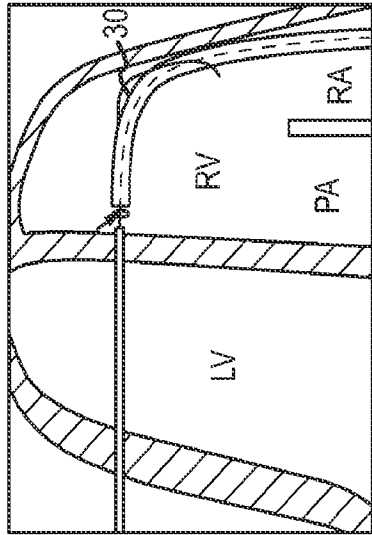

FIG. 4E

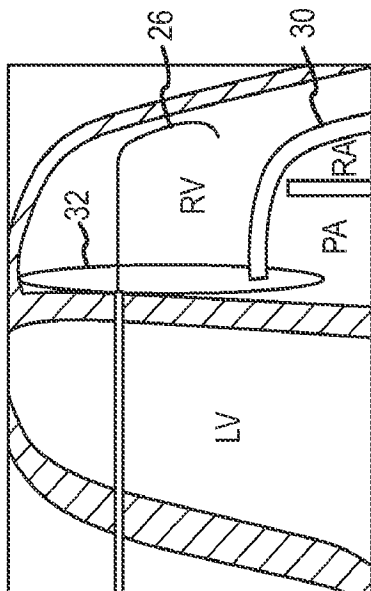

FIG. 4C

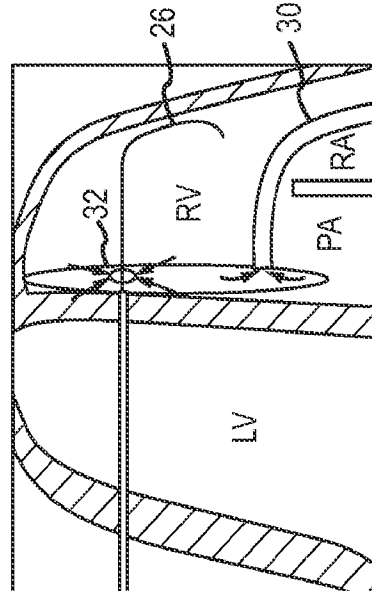

FIG. 4D

16/44

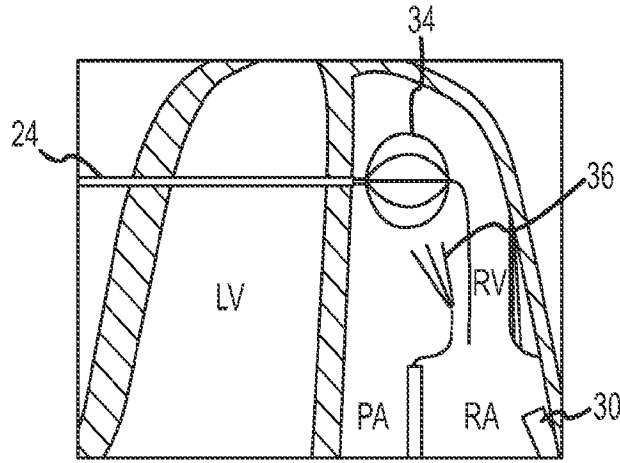

FIG. 5A

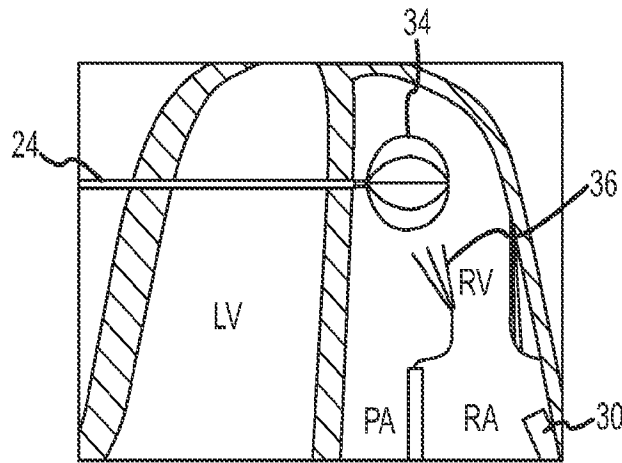

FIG. 5B

17/44

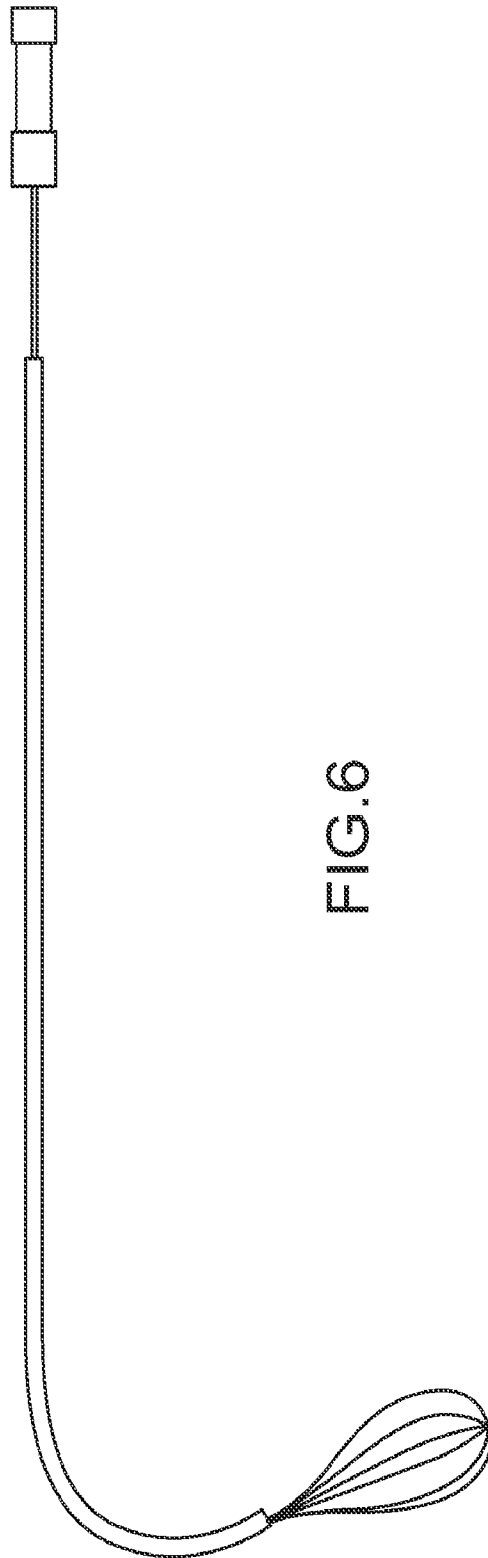
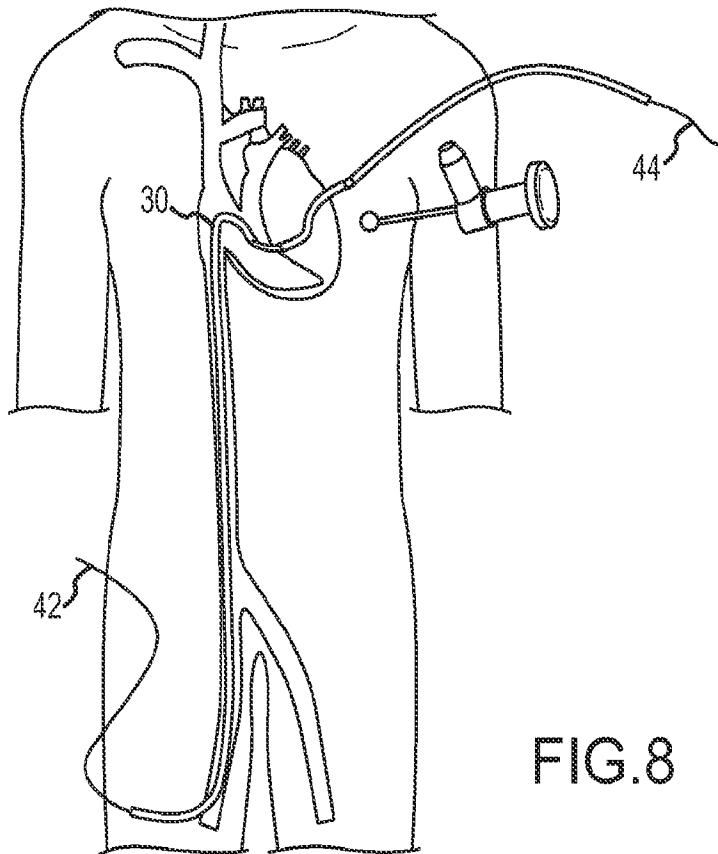
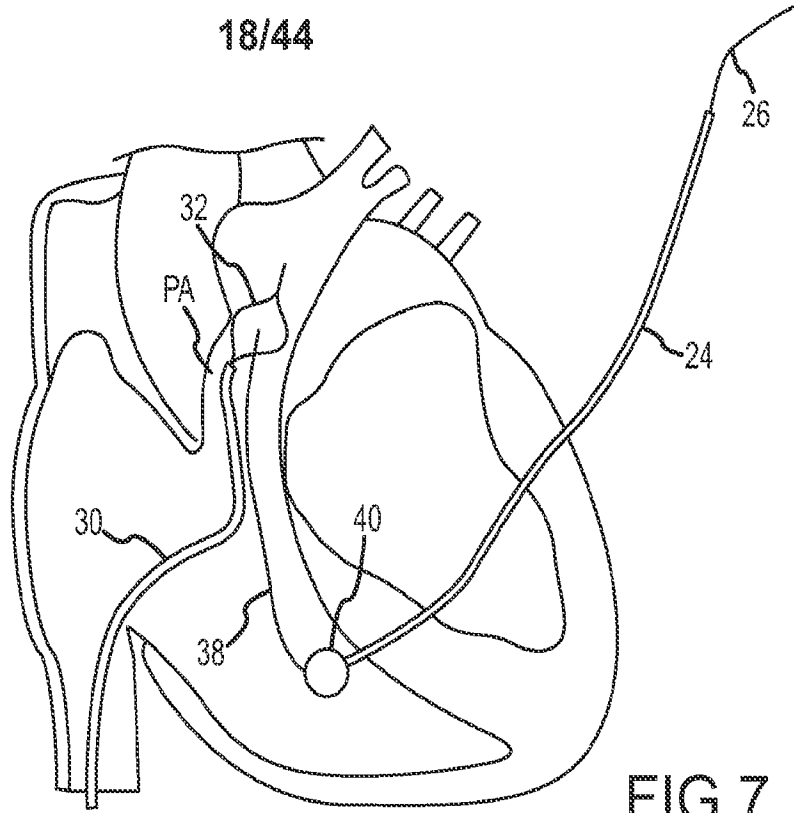

FIG.6

18/44



19/44

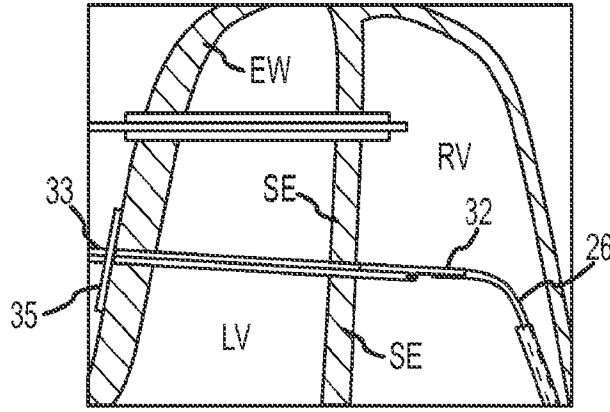

FIG.9

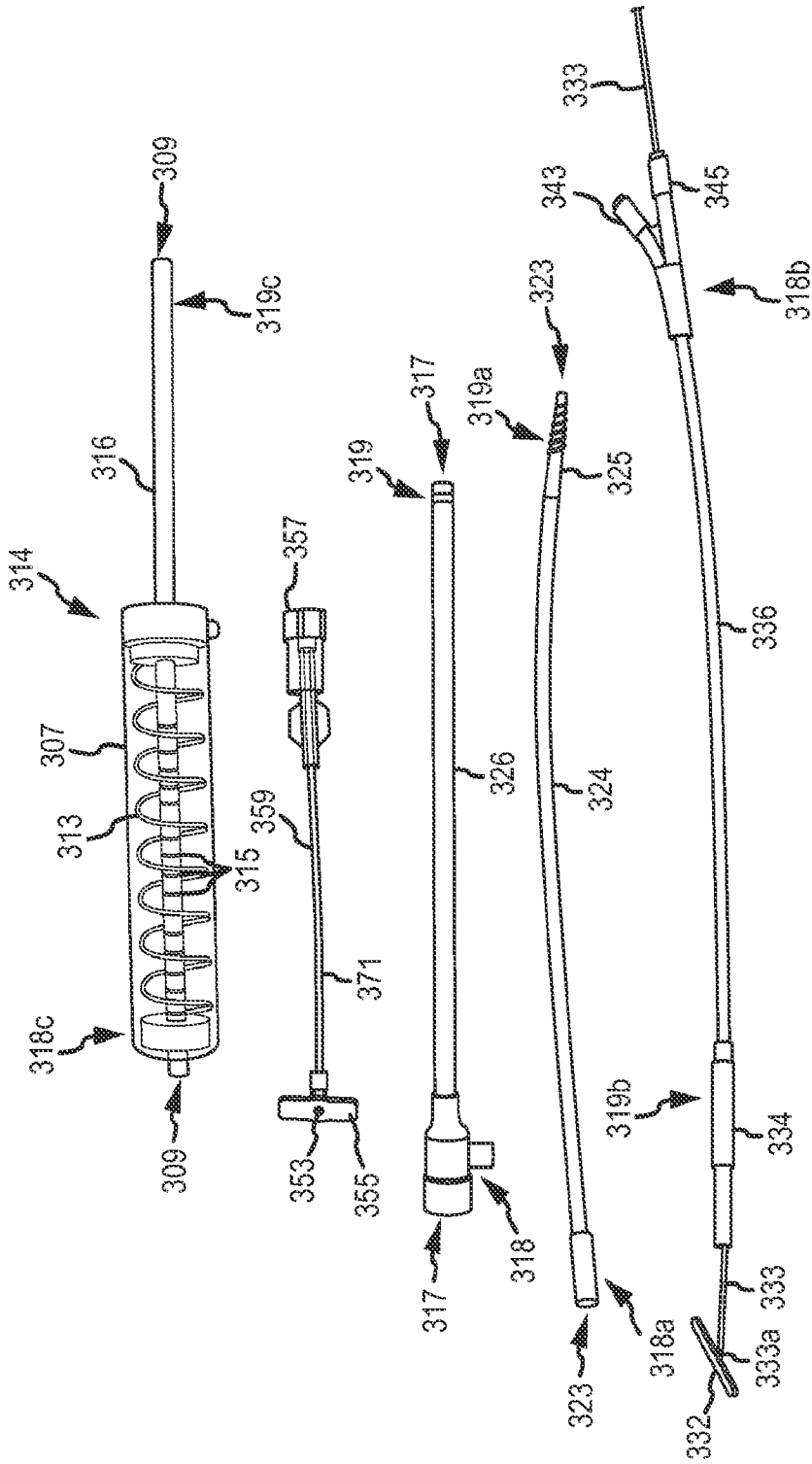

FIG.10

21/44

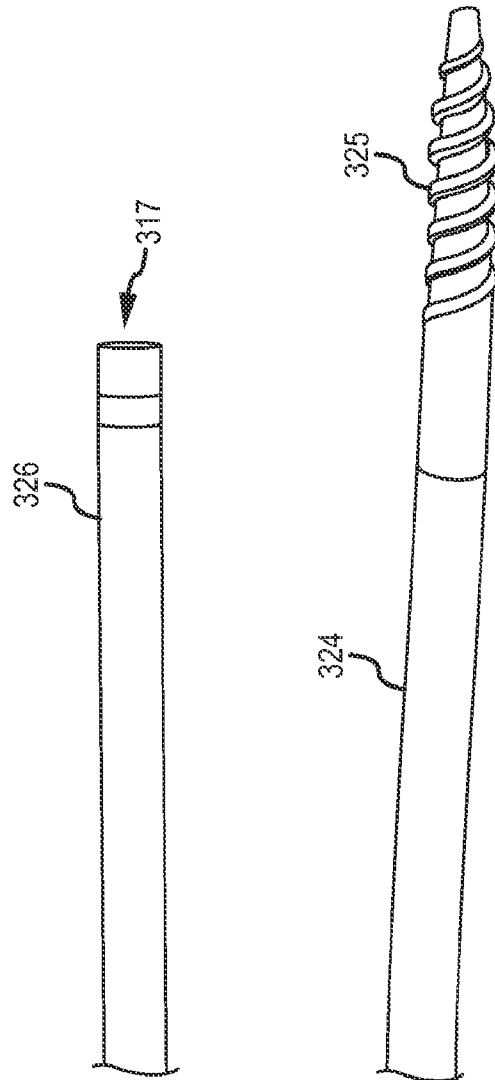

FIG.10A

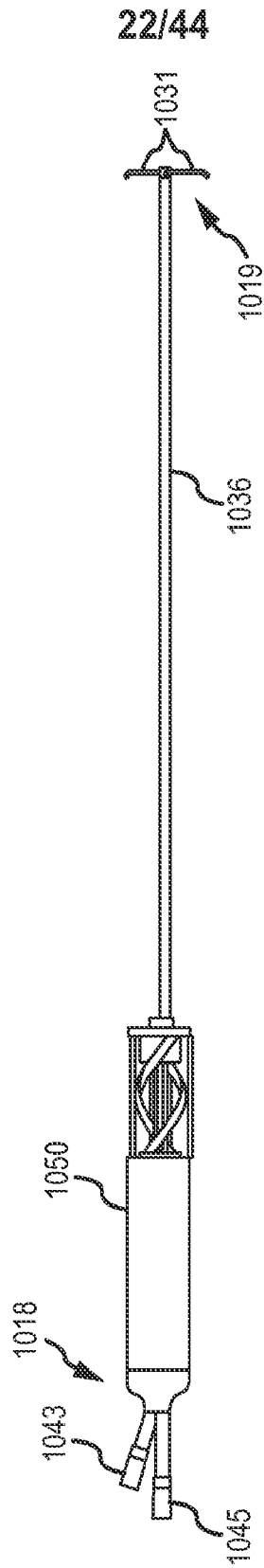

FIG. 10B



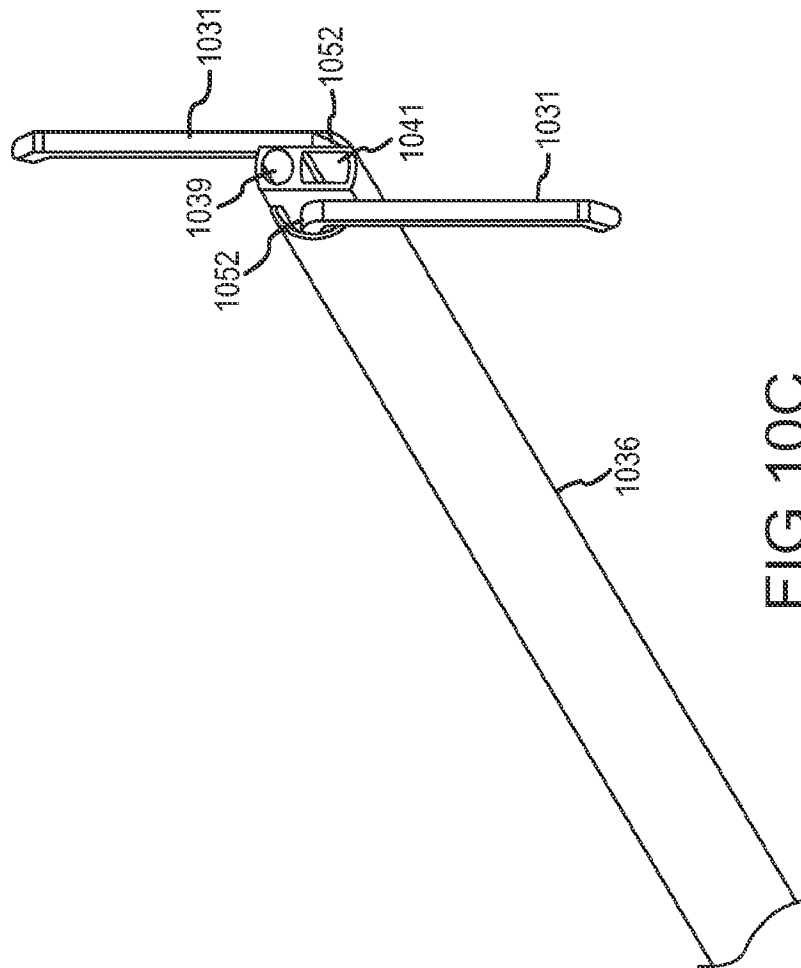

FIG.10C

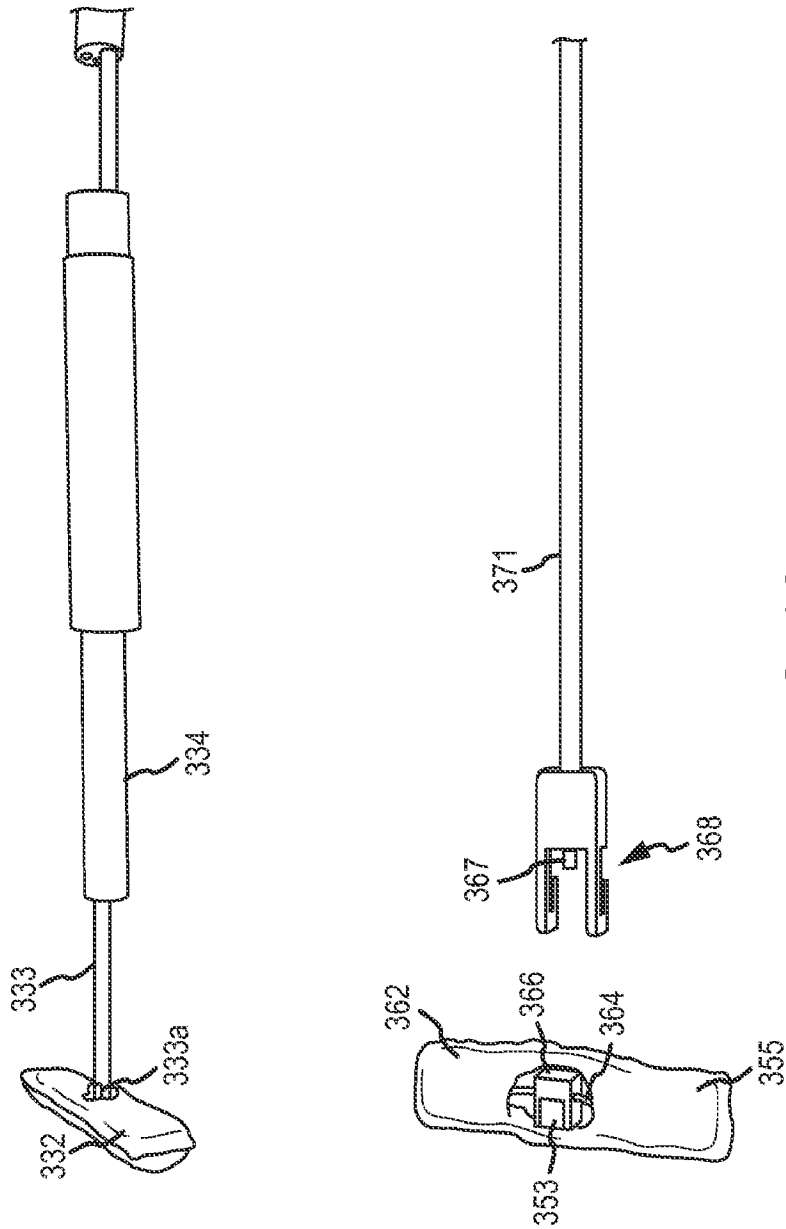

FIG.10D

25/44

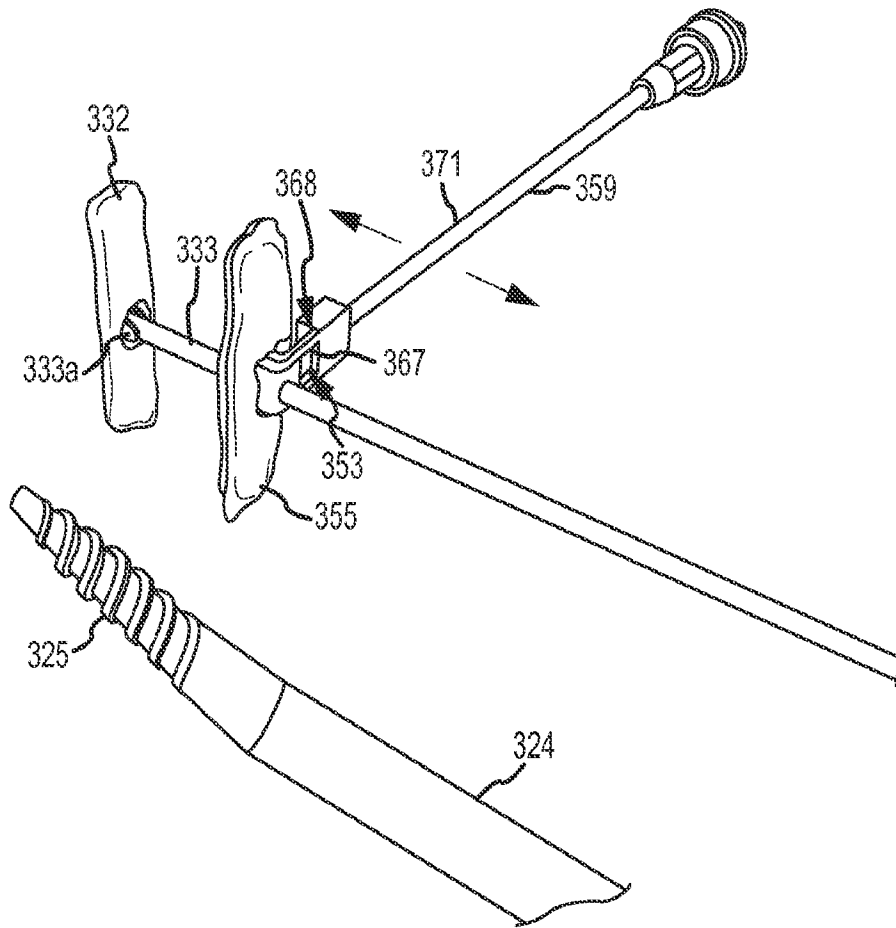

FIG. 10E

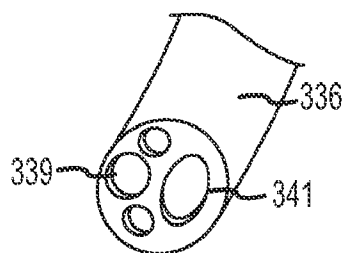

FIG. 10F

26/44

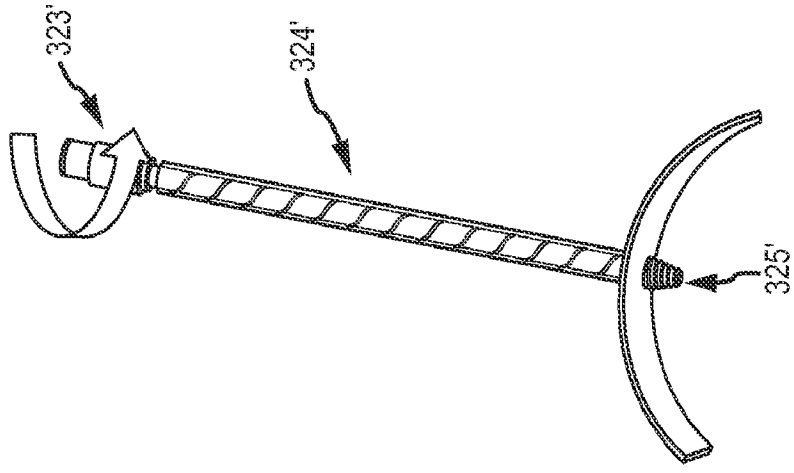

FIG. 10I

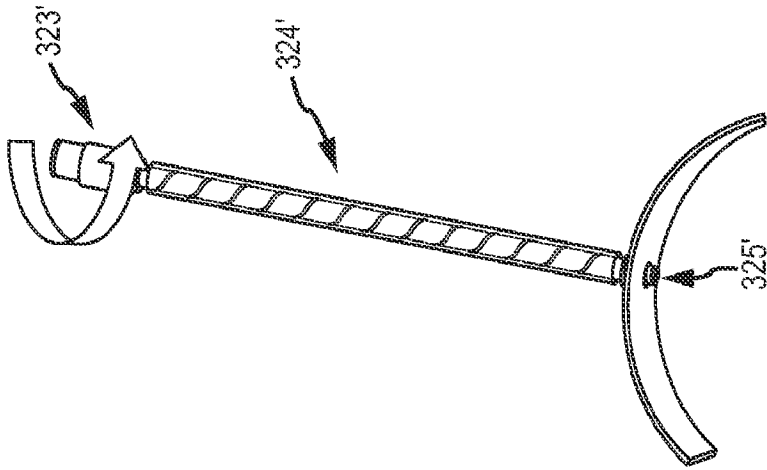

FIG. 10H

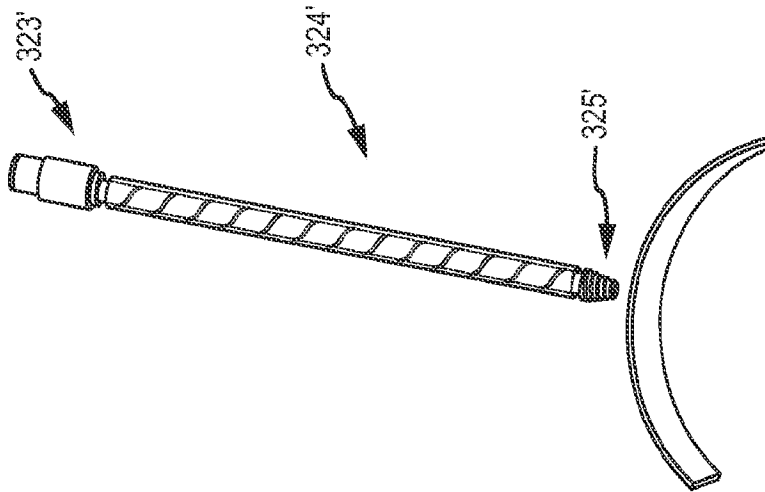
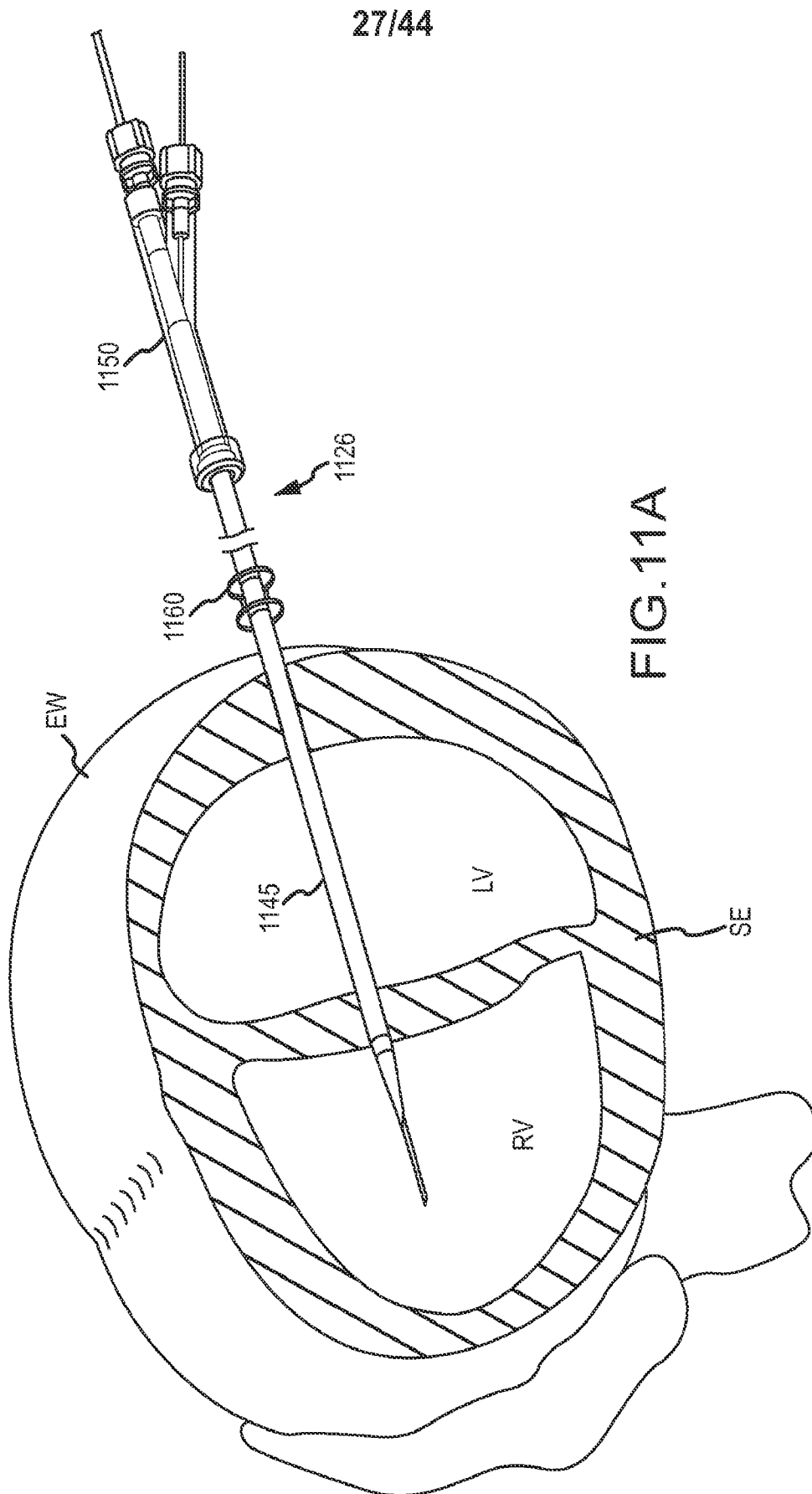
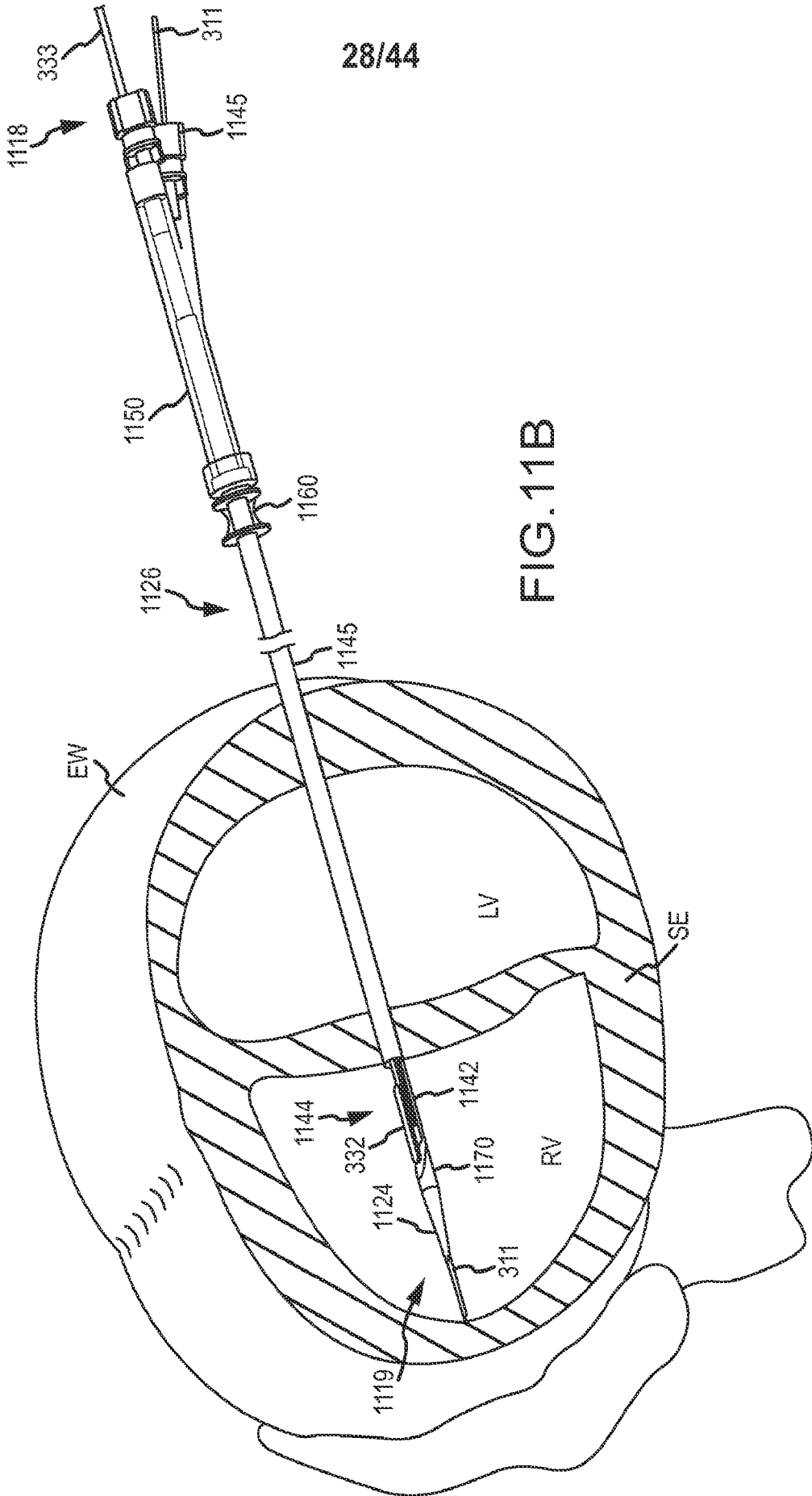

FIG. 10G





29/44

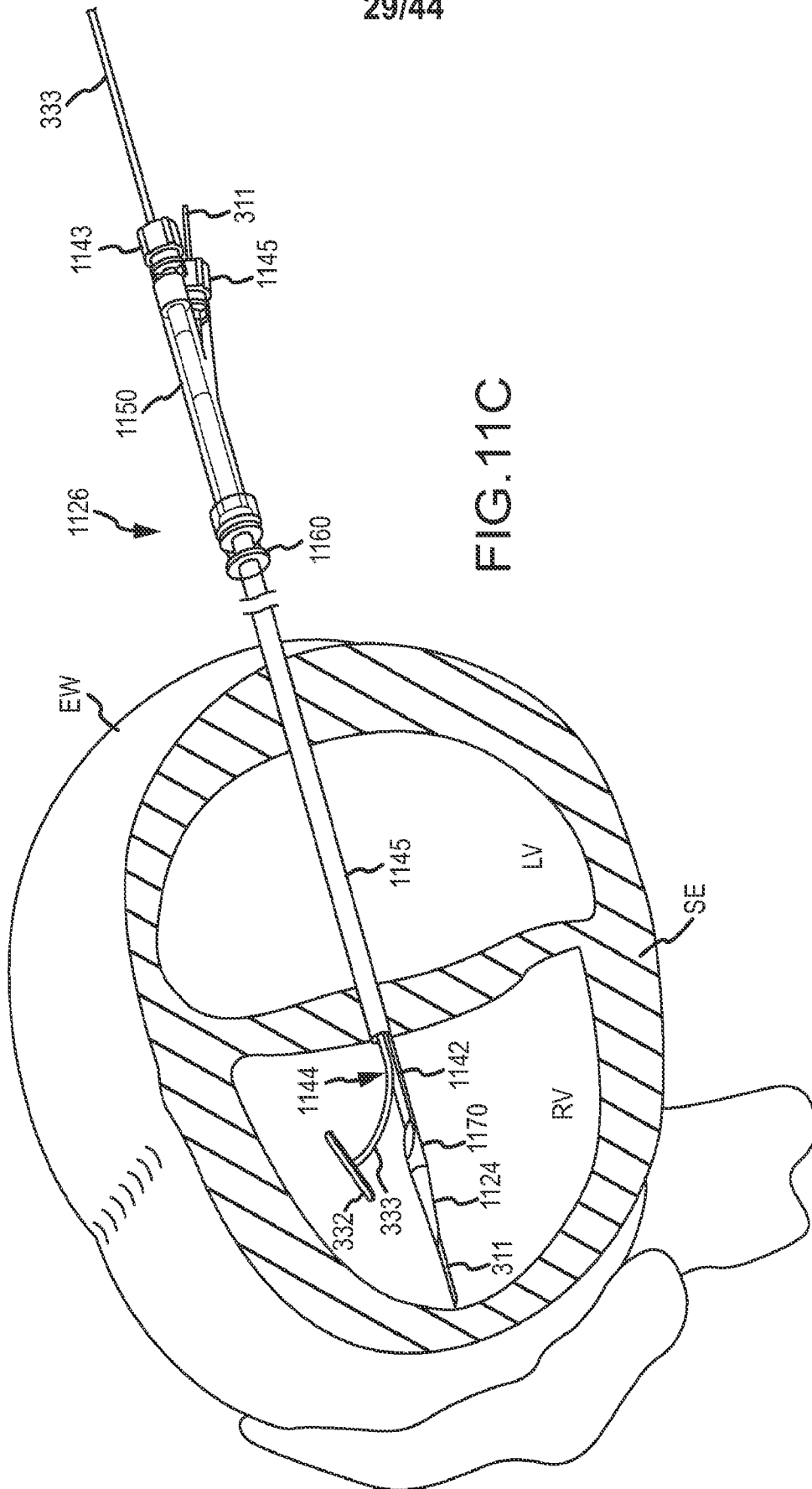

FIG.11C

30/44

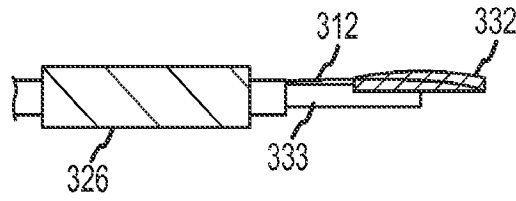

FIG. 12A

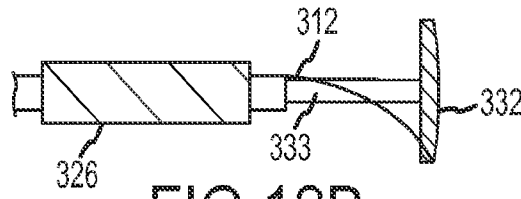

FIG. 12B



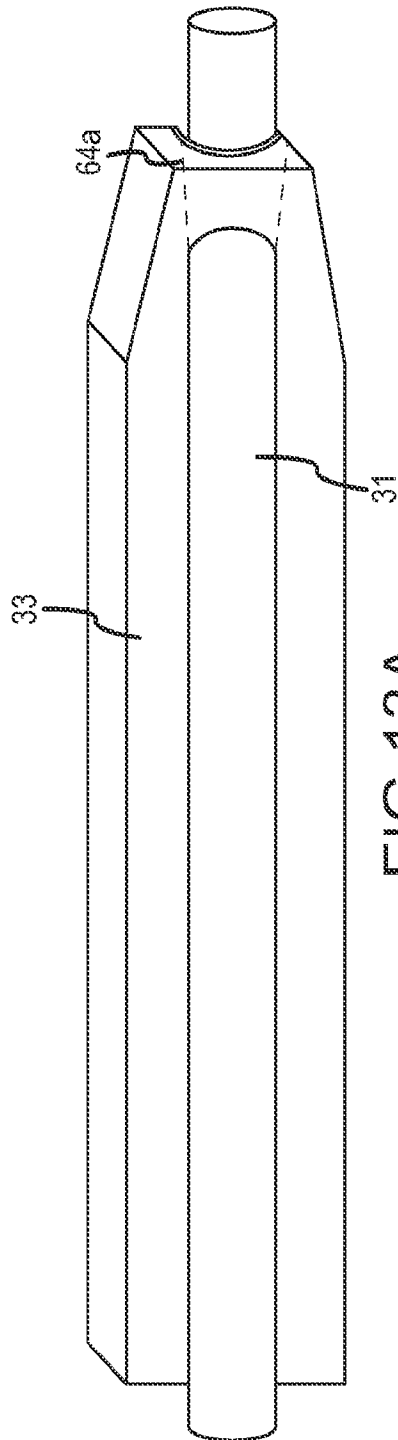

FIG. 13A

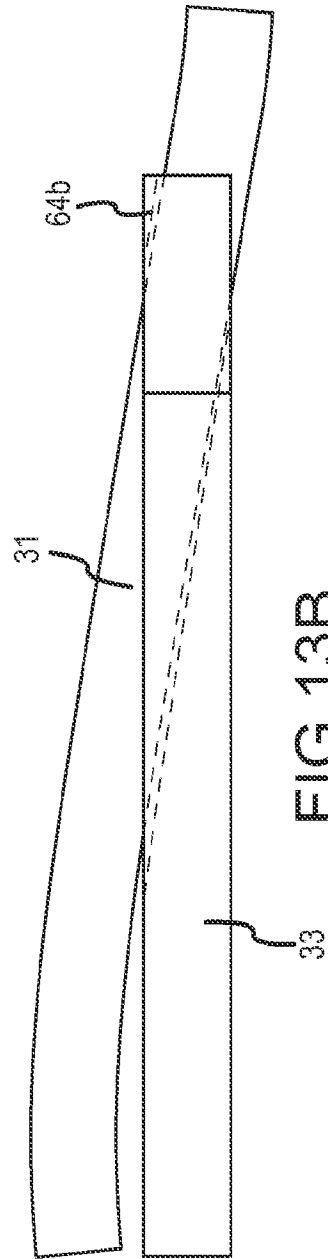

FIG. 13B

32/44

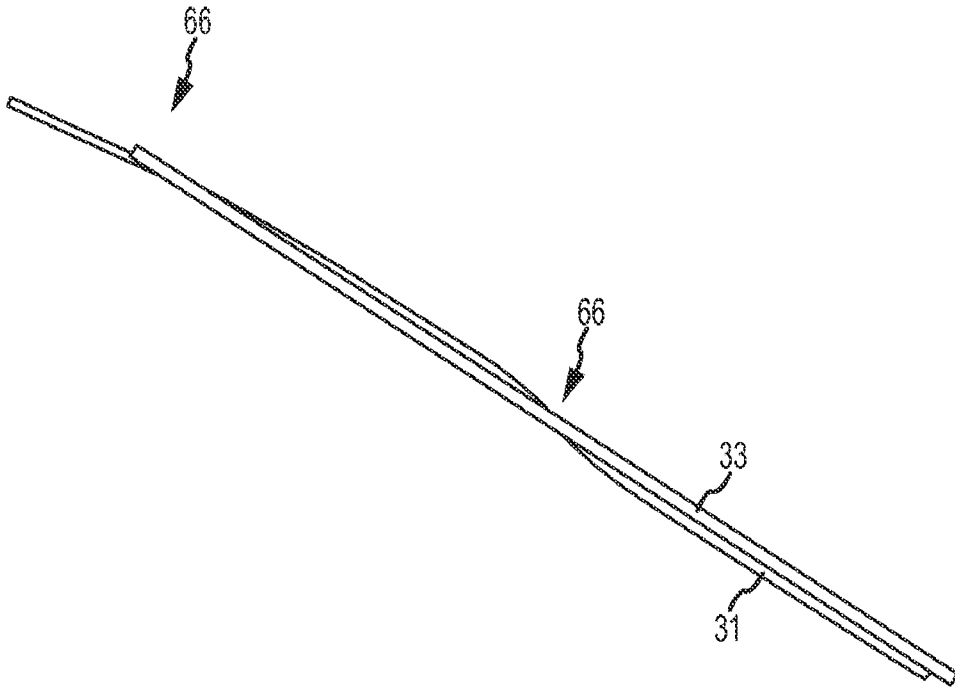

FIG. 13C

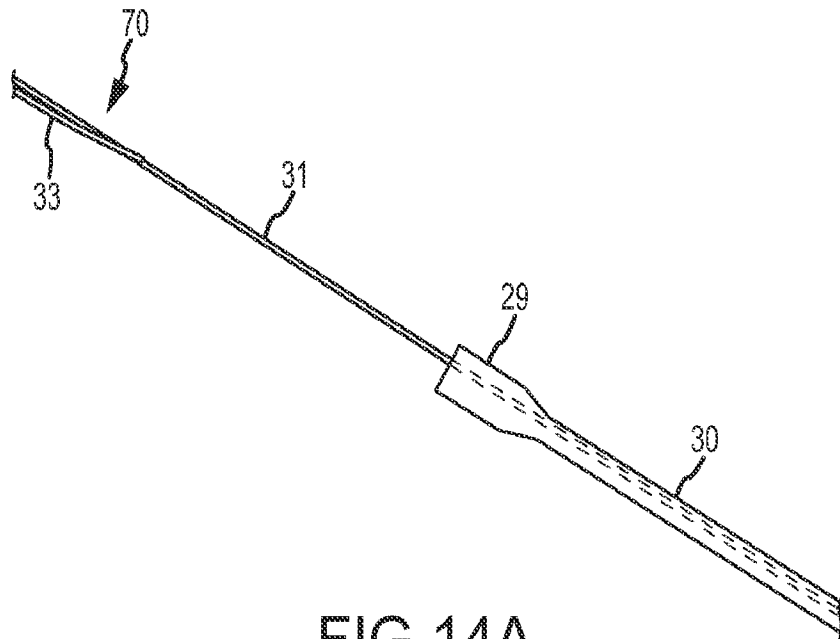

FIG. 14A

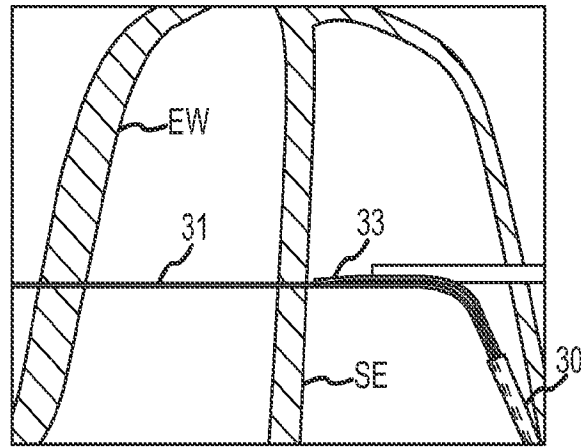

FIG.14B

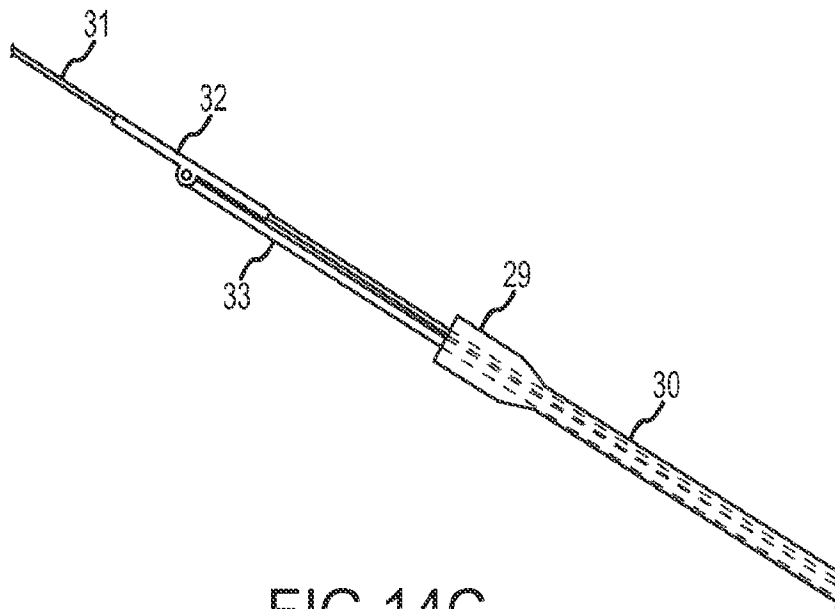

FIG.14C

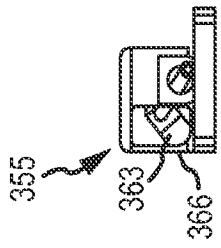

FIG. 15B

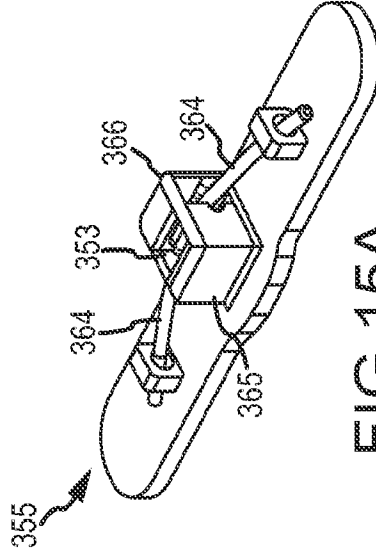

FIG. 15A

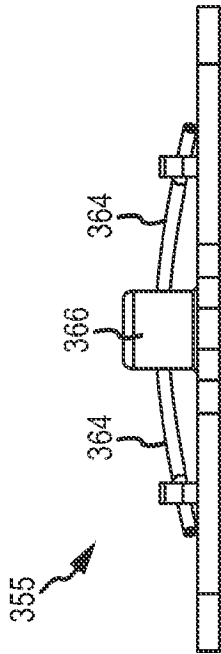

FIG. 15C

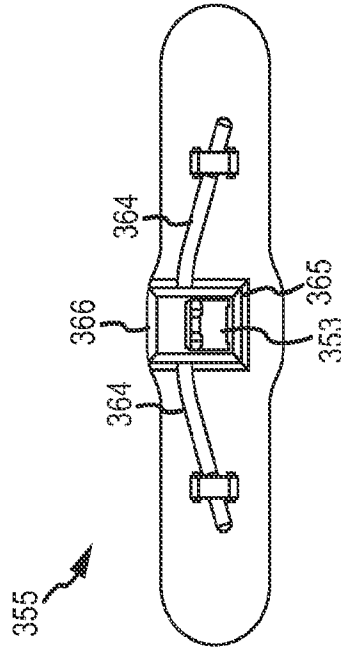

FIG. 15D

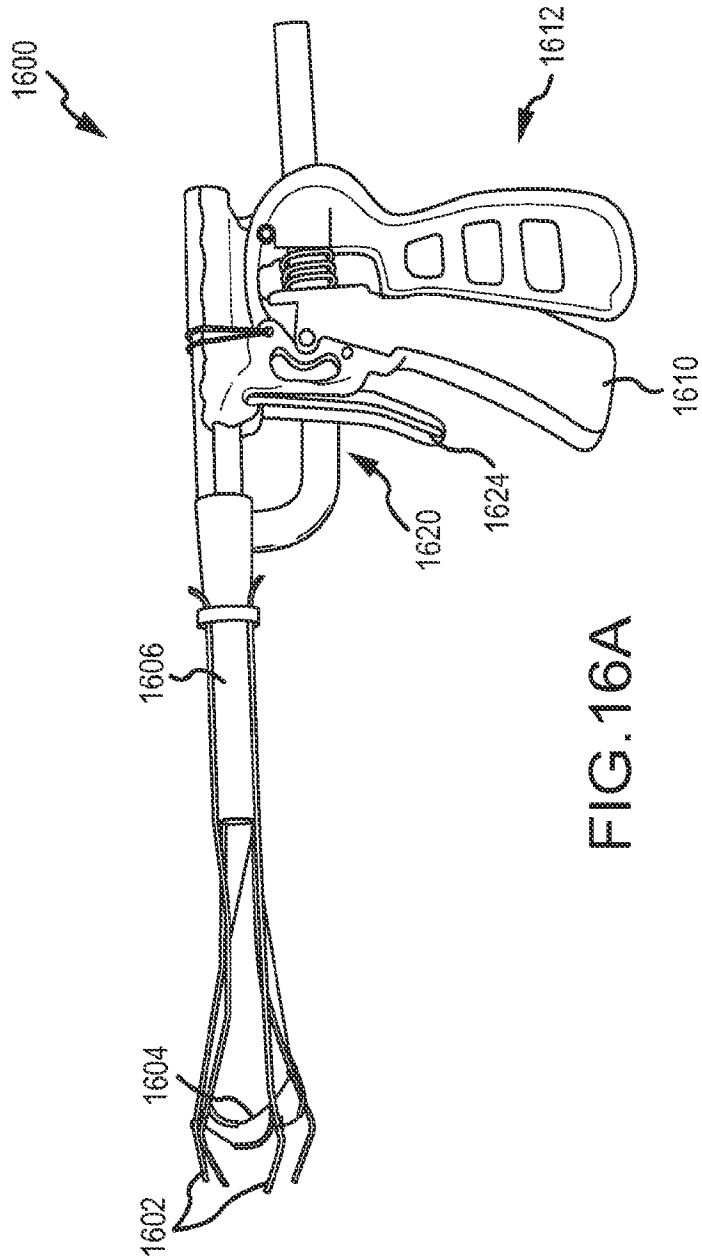

FIG. 16A

36/44

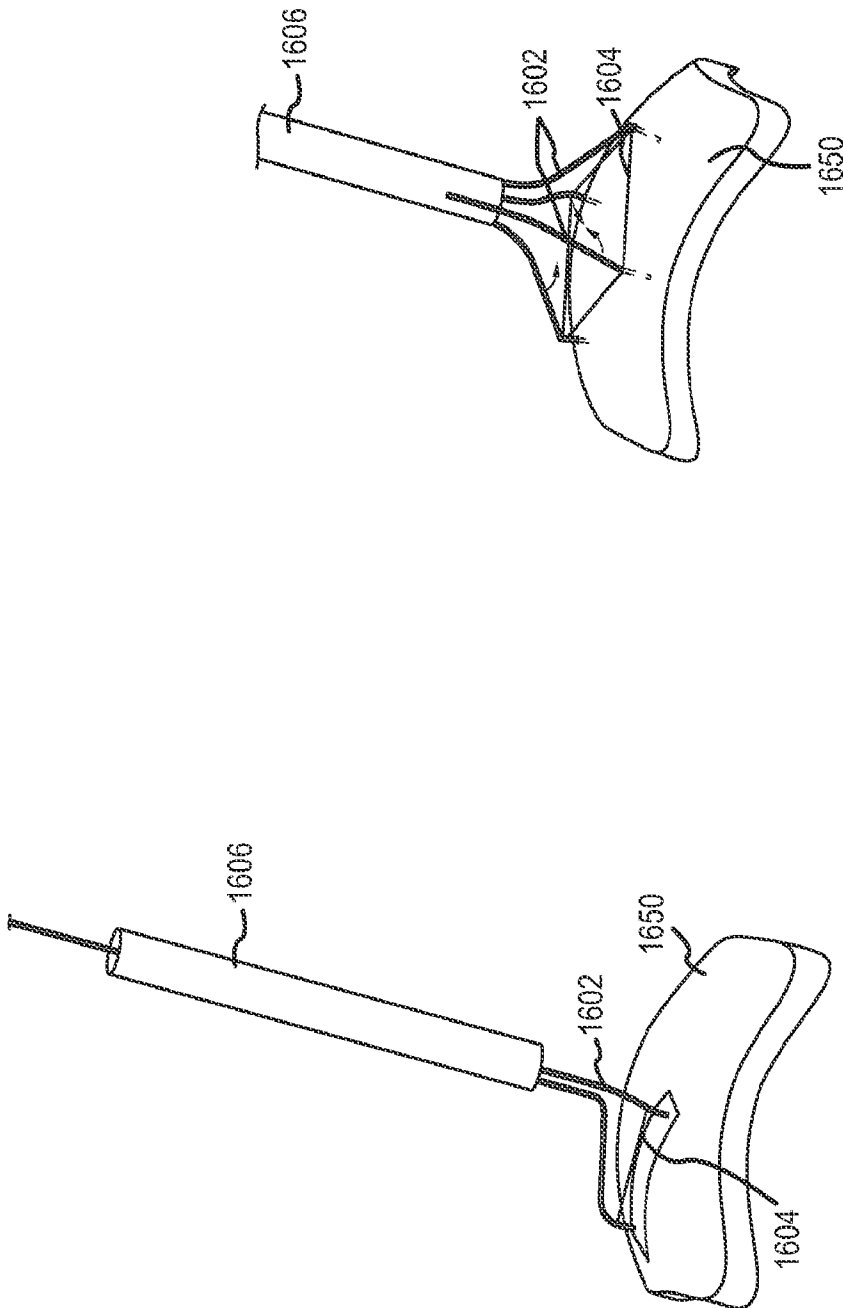

FIG. 16C

FIG. 16B

37/44

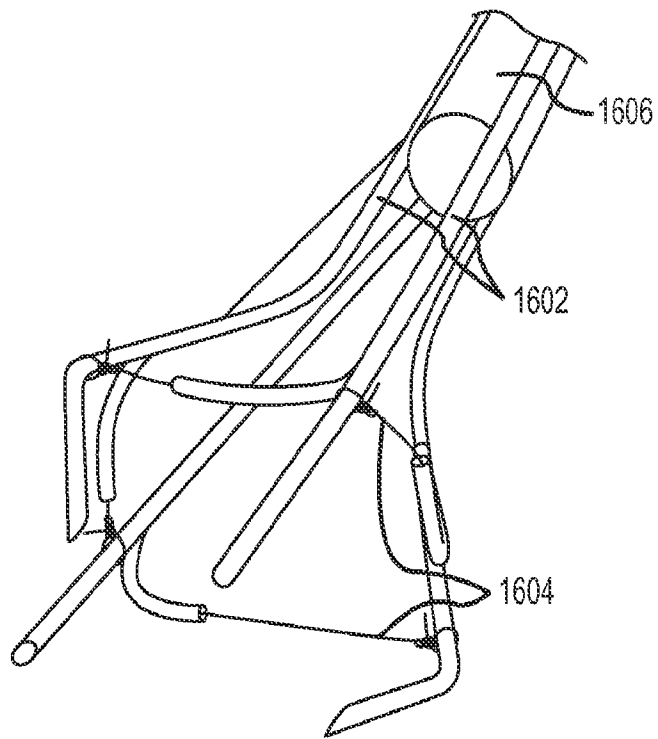

FIG.16D

38/44

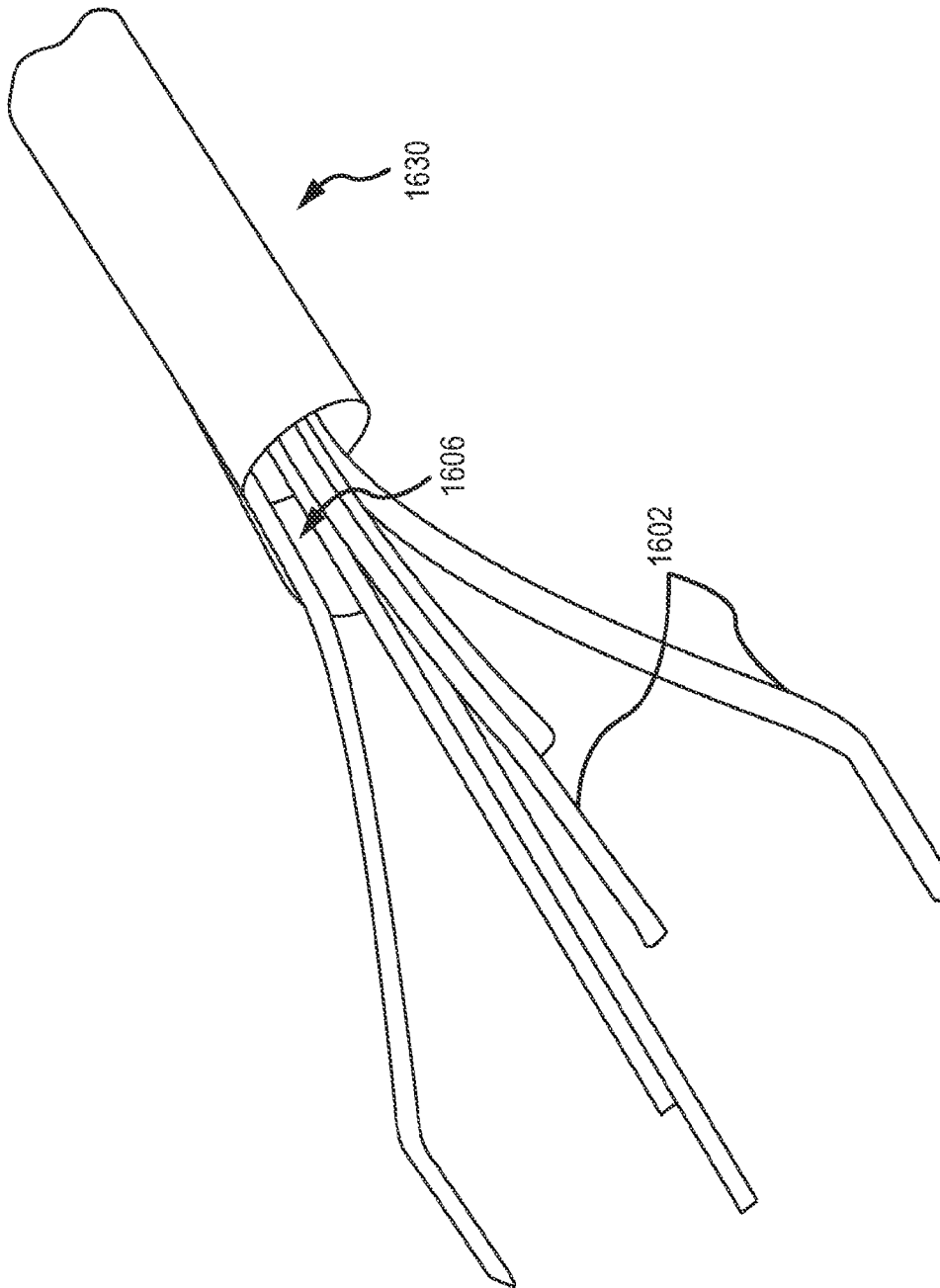

FIG.16E



39/44

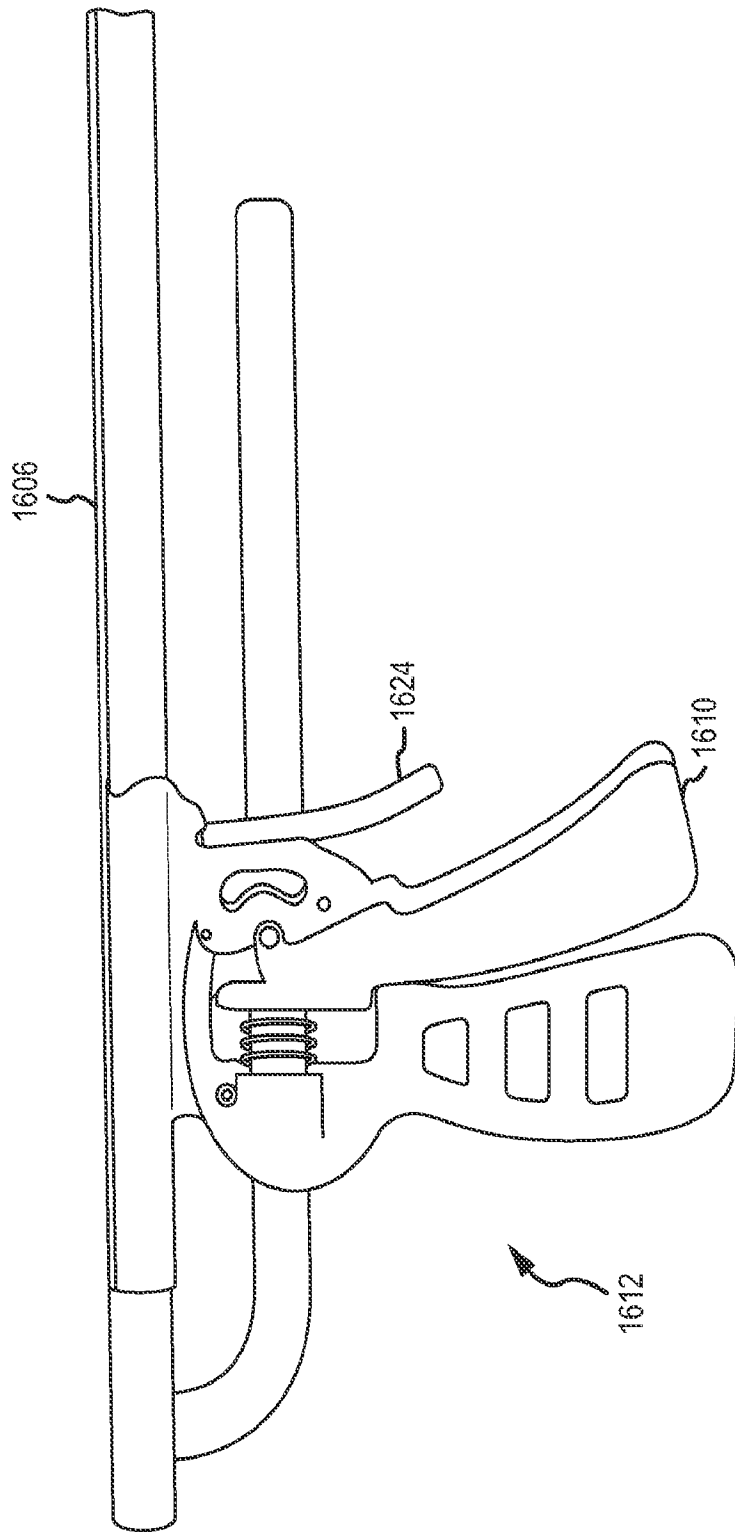

FIG. 16F

40/44

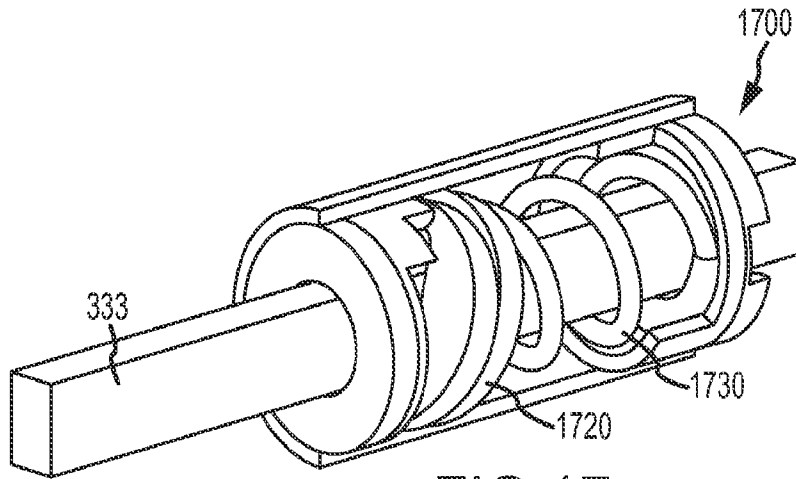

FIG. 17

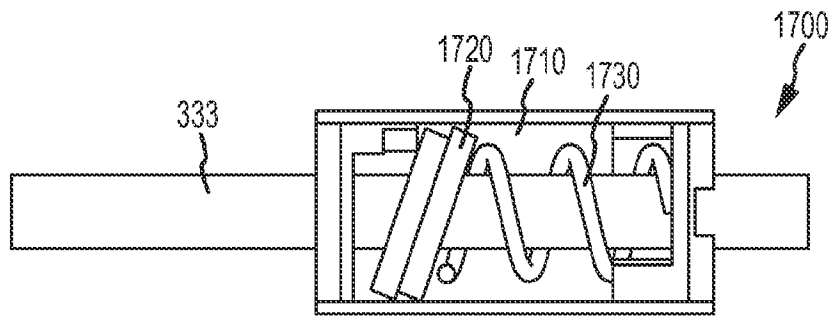

FIG. 17A

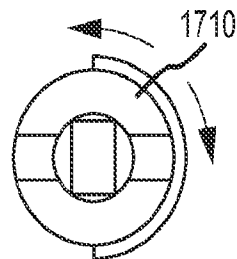

FIG. 17B

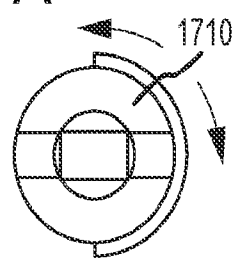

FIG. 17C

41/44

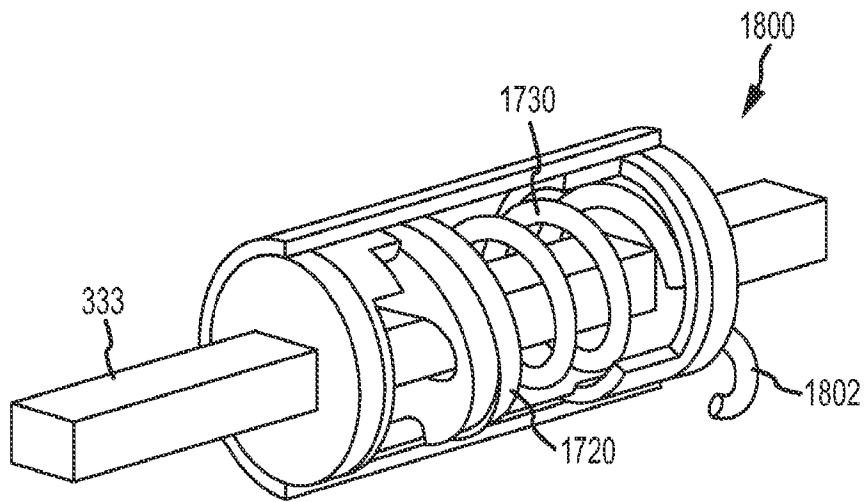

FIG. 18

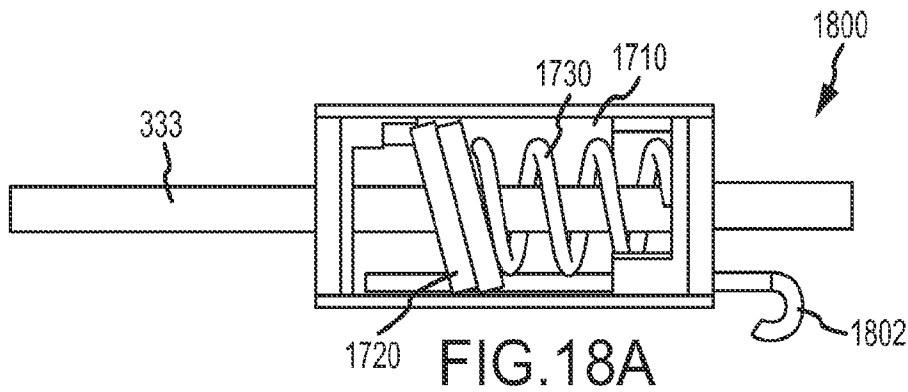

FIG. 18A

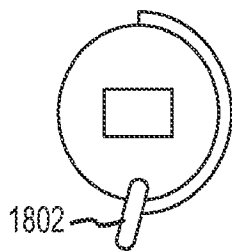

FIG. 18B

42/44

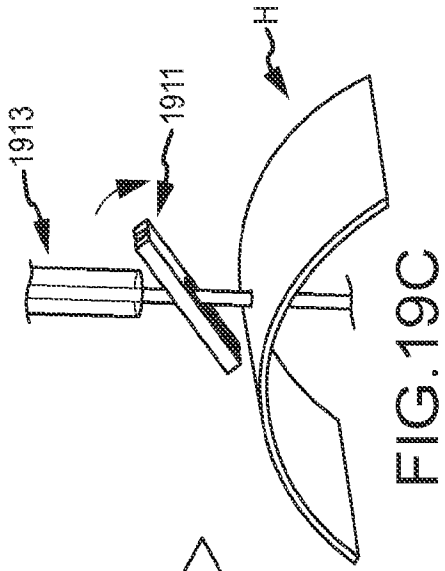

FIG. 19C

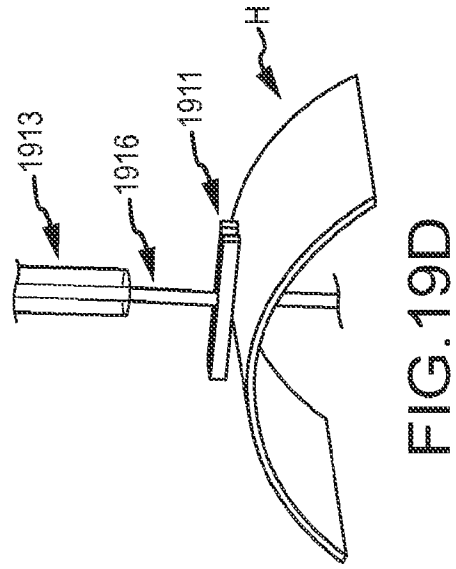

FIG. 19D

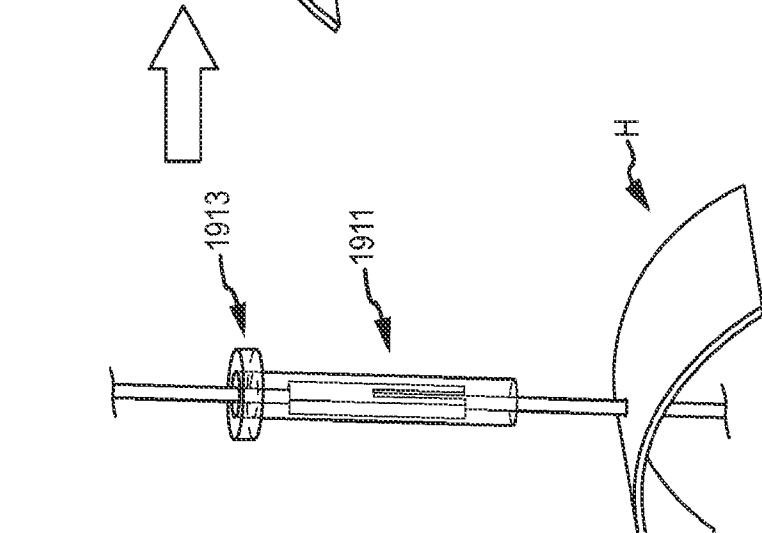

FIG. 19B

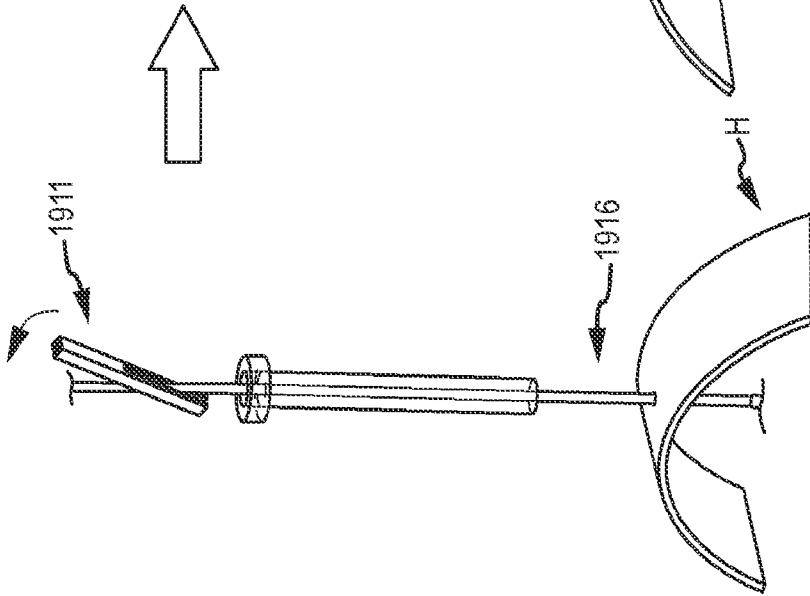

FIG. 19A

43/44

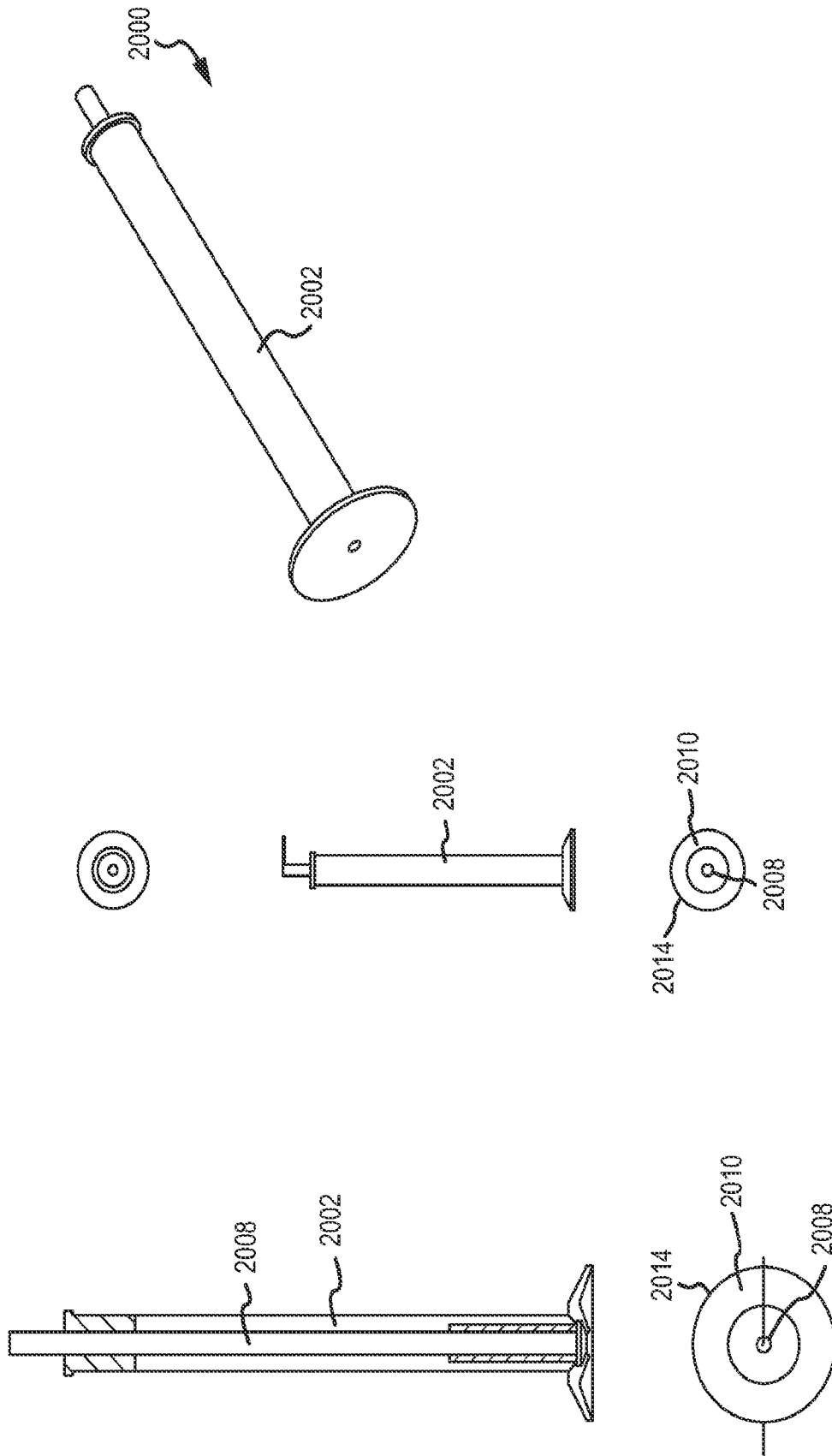

FIG.20

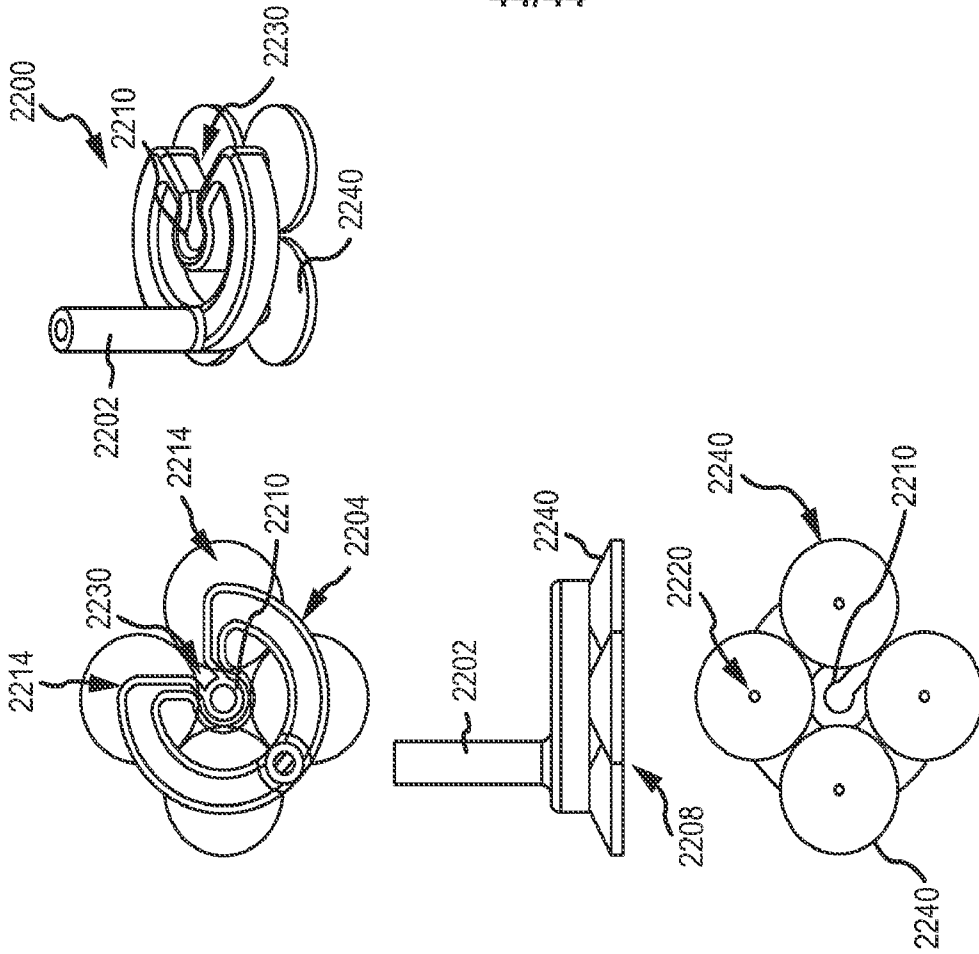

FIG. 22

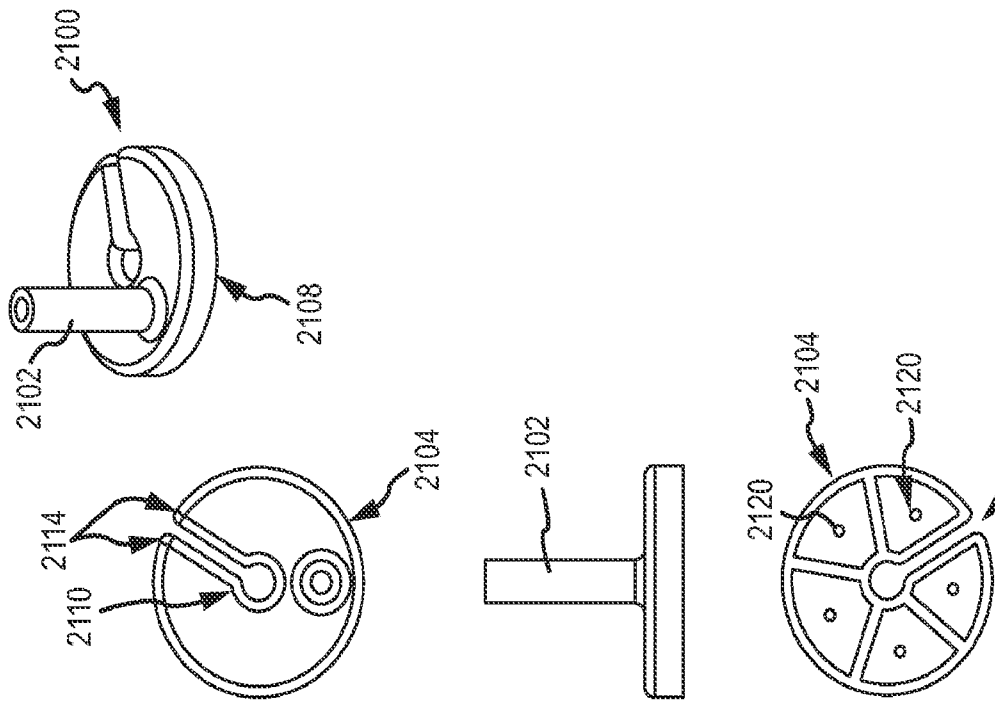

FIG. 21

**INTERNATIONAL SEARCH REPORT**

International application No.  
PCT/US12/58074

**A. CLASSIFICATION OF SUBJECT MATTER**  
 IPC(8) - A61B 1/32 (2013.01)  
 USPC - 600/201, 227-229, 37; 606/1  
 According to International Patent Classification (IPC) or to both national classification and IPC

**B. FIELDS SEARCHED**

Minimum documentation searched (classification system followed by classification symbols)  
 IPC(8): A61B 1/32 (2013.01)  
 USPC: 600/201, 227-229, 37; 606/1

Documentation searched other than minimum documentation to the extent that such documents are included in the fields searched

Electronic data base consulted during the international search (name of data base and, where practicable, search terms used)  
 MicroPatent (US-G, US-A, EP-A, EP-B, WO, JP-bib, DE-C,B, DE-A, DE-T, DE-U, GB-A, FR-A); Google/GoogleScholar; DialogPro;  
 PubMed/MEDLINE: heart, suction, vacuum, ratchet, hemostasis, grip

**C. DOCUMENTS CONSIDERED TO BE RELEVANT**

Category*	Citation of document, with indication, where appropriate, of the relevant passages	Relevant to claim No.
X --- Y	US 2009/0093670 A1 (ANNEST, LS et al.) April 9, 2009, figures 5, 11, 11a-11c, 12b, 12c, 13-15, 32-39, 40, 41; paragraphs [0077], [0083]-[0086], [0088]	24, 27 ----- 25, 26, 28-30
Y	US 2006/0200002 A1 (GUENST, G) September 7, 2006, figures 4, 8; paragraphs [0018], [0049], [0051]-[0053], [0055], [0056]; Claim 1	1-14, 19-22, 23/21, 23/22, 25, 26, 28-30
Y	US 7326177 B2 (WILLIAMSON, IV, WP et al.) February 5, 2008, abstract; figures 1-3, 10; column 14, lines 10-28; column 15, lines 1-12	1-14, 19-22, 23/21, 23/22, 28, 29
Y	US 7146225 B2 (GUENST, GW et al.) December 5, 2006, abstract; figures 2, 3; Claims 9, 23, 29-31	5
Y	US 6705988 B2 (SPENCE, PA et al.) March 16, 2004, column 5, lines 42-54	14, 23/21, 23/22

Further documents are listed in the continuation of Box C.

\* Special categories of cited documents:

"A" document defining the general state of the art which is not considered to be of particular relevance	"T" later document published after the international filing date or priority date and not in conflict with the application but cited to understand the principle or theory underlying the invention
"E" earlier application or patent but published on or after the international filing date	"X" document of particular relevance; the claimed invention cannot be considered novel or cannot be considered to involve an inventive step when the document is taken alone
"L" document which may throw doubts on priority claim(s) or which is cited to establish the publication date of another citation or other special reason (as specified)	"Y" document of particular relevance; the claimed invention cannot be considered to involve an inventive step when the document is combined with one or more other such documents, such combination being obvious to a person skilled in the art
"O" document referring to an oral disclosure, use, exhibition or other means	"&" document member of the same patent family
"P" document published prior to the international filing date but later than the priority date claimed	

Date of the actual completion of the international search 01 March 2013 (01.03.2013)	Date of mailing of the international search report <b>13 MAR 2013</b>
---	--

Name and mailing address of the ISA/US Mail Stop PCT, Attn: ISA/US, Commissioner for Patents P.O. Box 1450, Alexandria, Virginia 22313-1450 Facsimile No. 571-273-3201	Authorized officer: Shane Thomas  PCT Helpdesk: 571-272-4300 PCT OSP: 571-272-7774
---	--

**INTERNATIONAL SEARCH REPORT**

International application No.

PCT/US12/58074

**Box No. II Observations where certain claims were found unsearchable (Continuation of item 2 of first sheet)**

This international search report has not been established in respect of certain claims under Article 17(2)(a) for the following reasons:

1.  Claims Nos.:  
because they relate to subject matter not required to be searched by this Authority, namely:
  
2.  Claims Nos.:  
because they relate to parts of the international application that do not comply with the prescribed requirements to such an extent that no meaningful international search can be carried out, specifically:
  
3.  Claims Nos.:  
because they are dependent claims and are not drafted in accordance with the second and third sentences of Rule 6.4(a).

**Box No. III Observations where unity of invention is lacking (Continuation of item 3 of first sheet)**

This International Searching Authority found multiple inventions in this international application, as follows:

-\*\*\*-Please See Supplemental Page-\*\*\*-

1.  As all required additional search fees were timely paid by the applicant, this international search report covers all searchable claims.
2.  As all searchable claims could be searched without effort justifying additional fees, this Authority did not invite payment of additional fees.
3.  As only some of the required additional search fees were timely paid by the applicant, this international search report covers only those claims for which fees were paid, specifically claims Nos.:
4.  No required additional search fees were timely paid by the applicant. Consequently, this international search report is restricted to the invention first mentioned in the claims; it is covered by claims Nos.:

Claims 1-14, 19-30

**Remark on Protest**

- The additional search fees were accompanied by the applicant's protest and, where applicable, the payment of a protest fee.
- The additional search fees were accompanied by the applicant's protest but the applicable protest fee was not paid within the time limit specified in the invitation.
- No protest accompanied the payment of additional search fees.



-Continued From Box No. 3:

This application contains the following inventions or groups of inventions which are not so linked as to form a single general inventive concept under PCT Rule 13.1. In order for all inventions to be examined, the appropriate additional examination fees must be paid.

Group I: Claims 1-14 and 19-30 are directed toward a system for engaging epicardial tissue of a patient's heart, the system comprising: an elongate tool body extending between a proximal end and a distal end, the elongate tool body being insertable through a body wall of the patient and the elongate tool body having a working lumen through which an intracardiac device is inserted to perform a medical procedure within a chamber of the heart; and a gripping device near the distal end of the elongate tool body and operable therewith, the gripping device being disposed radially outwardly of the working lumen and being configured to be releasably attached to the epicardial tissue of the heart around the working lumen and an access site of the intracardiac device when performing the medical procedure within the chamber; wherein the gripping device is coupled with an actuator that is articulable from outside the patient body so as to move the gripping device radially inwardly toward an axis of the elongate tool body so as to facilitate stabilizing or hemostasis of the heart about the intracardiac device.

Group II: Claims 15-18 are directed toward a tissue engagement device comprising: an arcuate suction channel having a plurality of suction ports configured to releasably engage epicardial tissue of a patient's heart via suction through the plurality of suction ports; a suction lumen in fluid communication with the arcuate suction channel, the suction lumen being couplable with a suction device disposed external to the patient to provide suction to the arcuate suction channel; and an access slot extending radially from a centrally located aperture, the access slot allowing the arcuate suction channel to be inserted over a cannula that facilitates in performing a medical procedure within a chamber of the patient's heart, wherein the centrally located aperture is shaped and sized to receive the cannula and be releasably secured thereto.

The inventions listed as Groups I-II do not relate to a single general inventive concept under PCT Rule 13.1 because, under PCT Rule 13.2, they lack the same or corresponding special technical features for the following reasons: the special technical features of Group I include a system for engaging epicardial tissue of a patient's heart, the system comprising: an elongate tool body extending between a proximal end and a distal end, the elongate tool body being insertable through a body wall of the patient and the elongate tool body having a working lumen through which an intracardiac device is inserted to perform a medical procedure within a chamber of the heart; and a gripping device near the distal end of the elongate tool body and operable therewith, the gripping device being disposed radially outwardly of the working lumen and being configured to be releasably attached to the epicardial tissue of the heart around the working lumen and an access site of the intracardiac device when performing the medical procedure within the chamber; wherein the gripping device is coupled with an actuator that is articulable from outside the patient body so as to move the gripping device radially inwardly toward an axis of the elongate tool body so as to facilitate stabilizing or hemostasis of the heart about the intracardiac device, which are not present in Group II, Group II having special technical features including an arcuate suction channel having a plurality of suction ports configured to releasably engage epicardial tissue of a patient's heart via suction through the plurality of suction ports; a suction lumen in fluid communication with the arcuate suction channel, the suction lumen being couplable with a suction device disposed external to the patient to provide suction to the arcuate suction channel; and an access slot extending radially from a centrally located aperture, the access slot allowing the arcuate suction channel to be inserted over a cannula that facilitates in performing a medical procedure within a chamber of the patient's heart, wherein the centrally located aperture is shaped and sized to receive the cannula and be releasably secured thereto.

Since none of the special technical features of the Groups I-II inventions are found in more than one of the inventions, unity of invention is lacking.