



- (51) **International Patent Classification:**
H05K 7/20 (2006.01) *H05K 7/18* (2006.01)
- (21) **International Application Number:**
PCT/US2015/026465
- (22) **International Filing Date:**
17 April 2015 (17.04.2015)
- (25) **Filing Language:** English
- (26) **Publication Language:** English
- (71) **Applicant:** HEWLETT PACKARD ENTERPRISE DEVELOPMENT LP [US/US]; 11445 Compaq Center Drive West, Houston, TX 77070 (US).
- (72) **Inventors:** MAYER, Dave; 3404 E Harmony Rd., Ft. Collins, Colorado 80528 (US). ROESNER, Arlen L.; 3404 E Harmony Rd., Ft. Collins, Colorado 80528 (US).
- (74) **Agents:** ADEKUNLE, Olaolu O. et al.; Hewlett Packard Enterprise, 3404 E. Harmony Road, Mail Stop 79, Fort Collins, CO 80528 (US).
- (81) **Designated States** (unless otherwise indicated, for every kind of national protection available): AE, AG, AL, AM,

AO, AT, AU, AZ, BA, BB, BG, BH, BN, BR, BW, BY, BZ, CA, CH, CL, CN, CO, CR, CU, CZ, DE, DK, DM, DO, DZ, EC, EE, EG, ES, FI, GB, GD, GE, GH, GM, GT, HN, HR, HU, ID, IL, IN, IR, IS, JP, KE, KG, KN, KP, KR, KZ, LA, LC, LK, LR, LS, LU, LY, MA, MD, ME, MG, MK, MN, MW, MX, MY, MZ, NA, NG, NI, NO, NZ, OM, PA, PE, PG, PH, PL, PT, QA, RO, RS, RU, RW, SA, SC, SD, SE, SG, SK, SL, SM, ST, SV, SY, TH, TJ, TM, TN, TR, TT, TZ, UA, UG, US, UZ, VC, VN, ZA, ZM, ZW.

- (84) **Designated States** (unless otherwise indicated, for every kind of regional protection available): ARIPO (BW, GH, GM, KE, LR, LS, MW, MZ, NA, RW, SD, SL, ST, SZ, TZ, UG, ZM, ZW), Eurasian (AM, AZ, BY, KG, KZ, RU, TJ, TM), European (AL, AT, BE, BG, CH, CY, CZ, DE, DK, EE, ES, FI, FR, GB, GR, HR, HU, IE, IS, IT, LT, LU, LV, MC, MK, MT, NL, NO, PL, PT, RO, RS, SE, SI, SK, SM, TR), OAPI (BF, BJ, CF, CG, CI, CM, GA, GN, GQ, GW, KM, ML, MR, NE, SN, TD, TG).

Declarations under Rule 4.17:

- as to the identity of the inventor (Rule 4.17(i))
- as to applicant's entitlement to apply for and be granted a patent (Rule 4.17(ii))

[Continued on next page]

(54) **Title:** RACK ENCLOSURE WITH PERFORATIONS FOR COOLING

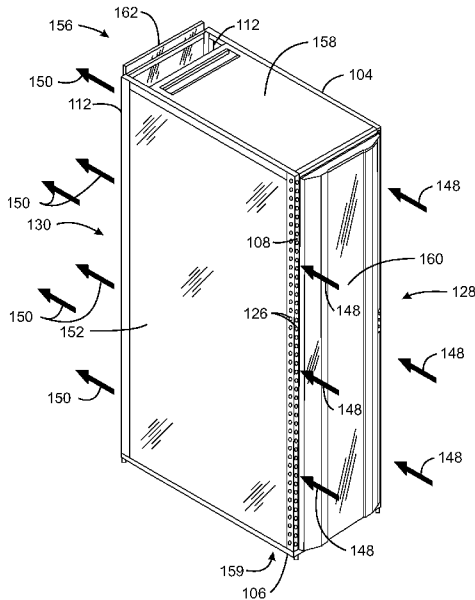

FIG. 100B
FIG. 1B

(57) **Abstract:** The present examples include a rack enclosure with perforations formed within vertical rack columns. Front vertical rack columns may include front perforations formed therein. The front perforations may draw air into the rack enclosure and further into a chassis. Side plenums along the side surface of the chassis may consume less space with the use of the front perforations. The space not consumed by the side plenums may be available to accommodate a chassis of a substantial volume. The chassis may expand a substantial width of the rack enclosure to house an enlarged or a maximum number of computing components within the rack enclosure.

WO 2016/167804 A1

Published:

— *with international search report (Art. 21(3))*

RACK ENCLOSURE WITH PERFORATIONS FOR COOLING

BACKGROUND

[0001] Computing centers often contain large numbers of computing components. For example, the computing components may include servers, modems, routers, and other equipment, such as power, cooling, and cable management resources, among others. A rack enclosure may provide a standardized structure to support and mount the computing components inside of the rack enclosure.

[0002] The computing components often generate a substantial amount of heat while mounted within the rack enclosure. In particular, any component that uses power will generate heat, as it is an unavoidable by-product. However, various heat removal techniques may dissipate the heat in order to improve reliability and prevent premature failure of the computing components. Thermal management is one type of heat removal technique used to dissipate heat away from the point of generation. The thermal management technique may include the use of cooling air, fans, or specialized materials, among others, for heat removal. For example, the cooling air may be limited by flowing within a chassis to cool the computing components. In particular, the heat removal technique is merely limited to the width of the chassis to flow the cooling air.

BRIEF DESCRIPTION OF THE DRAWINGS

[0003] The advantages of the present examples are better understood by referring to the following detailed description and the attached drawings, in which:

[0004] Fig. 1A is a perspective view of an example of a rack;

[0005] Fig. 1B is a perspective view of an example of the rack including rack panels to form a rack enclosure;

[0006] Fig. 1C is a front view of an example of the rack enclosure;

[0007] Fig. 2 is a detailed perspective view of an example of front perforations formed in a front vertical rack column;

[0008] Fig. 3 is a block diagram of an example of a method for cooling heat generating computing components; and

[0009] Fig. 4 is a block diagram of an example of a method for forming a rack enclosure to channel air through side plenums and into side openings of a chassis.

DETAILED DESCRIPTION OF SPECIFIC EXAMPLES

[0010] A rack is a frame used to mount various computing components such as servers, modems, routers, and other computing components. The rack may include rack columns located at the four corners of the rack where openings may separate the rack columns. The insertion of side panels in the openings between the rack columns may convert the rack into a rack enclosure.

[0011] As described herein, a structure used to house the computing components may include a product, for example, a chassis. The chassis, along with the computing components housed therein, may be mounted in the rack enclosure. In other examples, the computing components may be mounted in the rack enclosure without the use of the chassis. For example, the rack enclosure may include a rack-mount server, a rack-mount modem, or the like. During normal computing operations, the computing components may generate a substantial amount of heat that may cause damage. Thus, proper cooling and ventilation techniques may cool the computing components and maintain the temperature within the chassis.

[0012] A plenum, e.g., an air plenum, is a volumetric space used to provide pathways where air flows through the pathways. Within a rack enclosure, the space between a rack panel and a wall of an installed chassis may form side plenums located along side surfaces of the chassis. Air may enter the rack enclosure at front air intakes located in front corner rack columns to flow into the side plenums. In this way, the side plenums may provide an auxiliary pathway for the air to flow along the side surfaces of the chassis and into the chassis. For example, the side plenums may provide a pathway for cooling air to flow into the chassis to cool computing components located therein. Typically, the side plenums are not used in a rack enclosure since corner rack columns prevent frontal access to the rack and where the chassis remains within the inner confines of the rack enclosure width. However, by using the side plenums within the rack enclosure as a pathway for air, the size and the number of the computing components can be maximized. In particular, the

open space along the side surfaces of the chassis may be used to flow the cooling air instead of using space inside of the chassis to flow the cooling air.

[0013] Examples described herein provide techniques to maximize spacing in a rack enclosure to mount computing components. In particular, the rack enclosure may include front perforations in front rack columns to allow air to enter side plenums. The air may flow through the side plenums to be directed into the chassis, for example, through openings along the sides of the chassis. The use of the front perforations may reduce the space needed in comparison to side plenums in the chassis that have air intakes with a substantial width. In this way, the rack enclosure may be considered a part of a thermal cooling solution. In the present examples, the width of the side plenums in the chassis may be reduced to provide additional space for other uses. As a result, the chassis may occupy a substantial width within the rack enclosure to house enlarged or a maximum number of computing components stored within for increased functionality.

[0014] Fig. 1A is a perspective view of an example of a rack 102. The rack 102 may include an upper frame 104 and a lower frame 106 substantially parallel to the upper frame 104. The rack 102 may include four vertical rack columns. Two front vertical rack columns 108 may connect to the upper frame 104 and to the lower frame 106 at front corners 110. Two rear vertical rack columns 112 may connect to the upper frame 104 and to the lower frame 106 at rear corners 114. The two front vertical rack columns 108 and the two rear vertical rack columns 112 may be parallel to each other and substantially perpendicular to the upper frame 104 and the lower frame 106. The term "substantially" is defined as being largely but not wholly of that which is specified. Middle vertical rack columns, for example, side barriers 116 may extend from a mid-way point 118 of the upper frame 104 to a mid-way point 120 of the lower frame 106. The side barriers 116 may be located on a first side 122 of the rack 102 and a second side 124 of the rack 102. The number of side barriers 116 may vary depending on manufacturing specifications. The term "vertical," as used herein, may refer to a directional orientation that extends in a plane substantially perpendicular to a reference surface, such as the upper frame 104 and the lower frame 106.

[0015] Each of the front vertical rack columns 108 may include a number of perforations. The two front vertical rack columns 108 at a front side 128 of the rack 102 may include front perforations 126 formed along the vertical length of the columns 108.

[0016] A chassis 132 may be mounted in the rack 102 to house various computing components 134. The chassis 132 may be a four-sided structure including a front surface 136, a rear surface 138, and side surfaces 140. The chassis 132 may include side openings 144 located at the side surfaces 140 for the intake of air. The chassis 132 may have a square shape, a rectangle shape or any shape that the rack 102 can accommodate. The chassis 132 may include slots 146 used to house and access the various computing components 134. The chassis 132 may be mounted in the rack 102 using rails, brackets, and other securing equipment. As previously discussed, other examples may directly mount the computing components 134 within the rack 102.

[0017] The computing components 134 located in the slots 146 may be heat-generating computing components. However, to maintain reliability and prevent equipment failure, the chassis 132 may use a cooling system to maintain its temperature. The cooling system may control the temperature of the chassis 132 by dissipating the heat generated by the computing components using ambient temperature air. For example, the chassis 132 may include at least one or more internal fans to draw ambient temperature air into the chassis 132. As herein described, the ambient temperature air is referred to as cooling air 148.

[0018] As described herein, the rack 102 may be designed for front-to-back cooling. The front-to-back cooling technique moves the cooling air 148 from the front side 128 of the rack 102 to the rear side 130 of the rack 102. In other examples, the rack 102 may be designed for other types of flow patterns, such as a side-to-side cooling technique where cooling air 148 may enter and exit the rack 102 in a direction perpendicular to the front-to-back airflow, for example, a right-to-left airflow or a left-to-right airflow.

[0019] The rack 102 may include rack panels 152 installed between one of the front vertical rack columns 108 and one of the rear vertical rack columns 112 on the first side 122 and the second side 124 of the rack 102. The rack panels 152 will be

further discussed with respect to Fig. 1B. A side plenum 154, as shown by the dashed lines, may be created with the mounting of the rack panels 152. In particular, the side plenums 154 may include the space located between one of the rack panels 152 and one of the side surfaces 140 of chassis 132. The side plenums 154 may be located on the first side 122 and the second side 124 of the rack 102

[0020] The chassis 132 may include an internal fan to pull the cooling air 148 from an external environment through the front perforations 126 into the side plenums 154. The side plenums 154 may direct the cooling air 148 into the chassis 132 at the side openings 144 to cool the computing components 134. For example, the side plenums 154 may provide an air pathway to route the cooling air 148 as it flows along the side surfaces 140, into the side openings 144, and over the computing components 134. The number of side openings 144 may vary depending on the number of computing components 134 located in the chassis 132. The cooling air 148 may remove heat generated by the computing components 134 and form a heated air 150. In this way, the environment of the chassis 132 may be cooled to a temperature to reduce or alleviate damage to the computing components 134. The heated air 150 may exit out of the rear side 130 of the rack 102, including any rear doors placed on the rack 102.

[0021] A filler material, for example, a foam gasket material may seal the side barriers 116 to the chassis 132. The side barriers 116 may direct the cooling air 148 into the side openings 144. For example, the side barriers 116 may prevent the cooling air 148 from flowing past the side openings 144 and into the rear side 130 of the rack 102. Without the side barriers 116, the heated air 150 that exits the rear surface 138 may be suctioned in a backward direction and into the side openings 144 of the chassis 132. In this case, the heated air 150 may mix with the cooling air 148 that flows into the side openings 144, thus, increasing the temperature of the cooling air 148 to form a warm air. The warm air may flow into the side openings 144 and may lessen the effect of the cooling air 148 to dissipate the heat within the chassis 132. Accordingly, the side barriers 116 may block the heated air 150 from entering the side openings 144 and may divert the cooling air 148 into the chassis 132 and not into the rear side 130 of the rack 102.

[0022] Fig. 1B is a perspective view of an example of the rack 102 including rack panels 152 to form a rack enclosure 156. The installation of the rack panels 152 forms the rack enclosure 156. The rack panels 152 may be installed between one of the front vertical rack columns 108 and one of the rear vertical rack columns 112 on the first side 122 and the second side 124 of the rack 102. The rack enclosure 156 may include a top cover 158 attached to the upper frame 104 and a bottom cover attached 159 attached to the lower frame 106. The front side 128 may include an installed front door 160 and the rear side 130 may include an installed rear door 162. The installation of the rack panels 152, the top cover 158, the bottom cover 159, the front door 160, and the rear door 162 may form the rack enclosure 156.

[0023] The rack enclosure 156 may protect the chassis 132 and the cooling components 134, as shown in Fig. 1A, from the environment. Further, the rack enclosure 156 may improve the circulation of the cooling air 148 by reducing or eliminating hot spots or irregular cooling of the components 134. The installation of the rack panels 152 to form the rack enclosure 156 may not hinder the cooling of the components 134 since the front perforations 126 are fully exposed, as shown in Fig. 1B.

[0024] Fig. 1C is a front view of an example of the rack enclosure 156. Like numbered items are as described with respect to Figs. 1A and 1B. The installation of the rack panels 152 may form the side plenums 154 on the first side 122 and the second side 124 of the rack enclosure 156. In particular, the side plenums 154 may include the internal space located between one rack panel 152 and the side surface 140 of the chassis 132 on the first side 122 and the second side 124. The cooling air 148, as shown in Fig. 1A, may enter the side plenums 154 through the front perforations 126. As a result, the side plenums 154 may consume less space within the rack enclosure 156 than in other designs.

[0025] For example, the width 157 of each side plenum 154 may be reduce from a range of about 0.5 inches to 1.0 inches on each side 122, 124 of the rack enclosure 156 to a range of about 0.1 inches to 0.2 inches on each side 122, 124. With the amount of space consumed by the side plenums 154 reduced, the chassis 132 may expand a substantial width of the rack enclosure 156. Consequently, the

chassis 132 of the present examples may house additional computing components 134 to optimize performance, enhance productivity, among other advantages.

[0026] Fig. 2 is a detailed perspective view of an example of front perforations 126 formed in a front vertical rack column 108. Like numbered items are as described with respect to Fig. 1A. As shown in Fig. 2, the front vertical rack column 108 may include a front-face 202 and a front side-face 204 at the front side 128 of the rack 102. The front perforations 126 may extend along the vertical length of the front-face 202 and along the vertical length of the front side-face 204. The cooling air 148, as shown by the arrows, may enter the rack 102 at the front perforations 126 along the front-face 202 and the side-face 204. The front perforations 126 may allow the cooling air 148 to flow into the side plenums 154, as shown in Fig. 1A.

[0027] The front vertical rack column 108 may include a front edge 206 located between the front-face 202 and the side-face 204. As illustrated in Fig. 2, the edge 206 may include a 90° angle. In some examples, the edge 206 may be rounded to form, for example, a curved edge. Manufacturing specifications and techniques may specify the configuration of the edge 206.

[0028] The material of the rack 102, the chassis 132, and the rack panels 152 may include a durable metal material such as a commercial grade steel. A metal forming technique, for example, drilling, punching, or the like, may form the front perforations 126. The shape of the front perforations 126 may include a slot, a circle, a square, an oval, or any other shape to allow the cooling air 148 to flow into the rack 102. As illustrated in Fig. 2, the front perforations 126 may be equally spaced and of a similar diameter along the vertical length of the front vertical rack columns 108. In other examples, the front perforations 126 may be unequally spaced and of different diameters or any other configuration that may provide consistent cooling of the computing components 134 of Fig. 1A. The vertical length of the rack column 108 and the spacing between the perforations 126 may determine the number of perforations formed therein. Further, the number of computing components 134 located within the chassis 132 may determine the number of front perforations 126 needed to provide sufficient intake of the cooling air 148.

[0029] Fig. 3 is a block diagram of an example of a method for cooling heat generating computing components. A rack enclosure may include two front vertical

rack columns and two rear vertical rack columns where a chassis may be mounted in the rack enclosure. The chassis may include a number of slots to house a number of heat generating computing components. A cooling system may maintain the temperature within the chassis in order to protect the computing components from excessive heat. In the present examples, the cooling system may include air at an ambient temperature. For example, the chassis may include internal fans to suction the air into the chassis to dissipate the heat. The air may initially flow through a number of front perforations formed within the front vertical rack columns. In particular, a front-face and a side-face of each of the front vertical rack columns may include the front perforations. At block 302, the air may be directed into the front perforations formed in each of the front vertical rack columns.

[0030] At block 304, the air may be routed through a side plenum. The side plenum may be formed between installed rack panels and the chassis to provide an air-pathway that extends along the side-surfaces of the chassis. The rack panels may be installed between the front vertical rack columns and rear vertical rack columns. The chassis may be mounted in the rack enclosure. The chassis may include a number of side openings located on its side-surfaces. At block 306, the air may be channeled into the side openings of the chassis. A number of side barriers may channel the air into the side openings. The air may flow over the computing components to remove the generated heat. In particular, the heat generated by the computing components may be transferred to the air to generate a heated air in the chassis. At block 308, the heated air may be directed out of the chassis and out of the rear side of the rack enclosure. For example, the heated air may exit a perforated rear door located at the rear side of the rack enclosure. In some examples, the air may flow into the rack enclosure in a front-to-back pattern or a side-to-side pattern.

[0031] Fig. 4 is a block diagram of an example of a method for forming a rack enclosure to channel air through side plenums and into side openings of a chassis. At block 402, a rack may include rack panels installed between vertical rack columns to form a rack enclosure. The vertical rack columns may include front vertical rack columns and rear vertical rack columns. At block 404, a chassis may be mounted in the rack enclosure to extend a substantial width of the rack enclosure. The chassis

may house a maximum number of computing components. With the mounting of the chassis, side plenums may be formed between the rack panels and the chassis. A number of side openings of the chassis may provide for the intake of air into the chassis. At block 406, a number of side barriers may be sealed to side surfaces of the chassis to block the air from flowing into a rear side of the rack enclosure and to divert the air into the side openings of the chassis. The air may flow into the chassis to remove heat generated by the computing components.

[0032] While the present techniques may be susceptible to various modifications and alternative forms, the embodiments discussed above have been shown only by way of example. However, it should again be understood that the techniques are not intended to be limited to the particular embodiments disclosed herein. Indeed, the present techniques include all alternatives, modifications, and equivalents falling within the true spirit and scope of the appended claims.

CLAIMS

What is claimed is:

1. A rack enclosure, comprising:
 - a rack comprising vertical rack columns and rack panels;
 - a plurality of perforations formed in the vertical rack columns, wherein the plurality of perforations are formed in a front vertical rack column, wherein air flows through the plurality of perforations formed in the front vertical rack column, and wherein heated air exits a rear side of the rack;
 - a chassis that comprises a plurality of openings on a side-surface of the chassis, wherein the chassis is mounted in the rack;
 - side plenums located between the chassis and the rack panels and along the side-surface of the chassis, wherein the air flows into the side plenums and into each of the plurality of openings;
 - a plurality of side barriers, wherein each side barrier is sealed to the side-surface of the chassis to channel the air into the plurality of openings; and
 - a plurality of heat-producing components housed in the chassis.
2. The rack enclosure of claim 1, wherein the side plenums comprise a space between the chassis and the rack panels, wherein the width of the space is about 0.1 inches to about 0.2 inches.
3. The rack enclosure of claim 1, wherein the chassis extends across a substantial width of the rack enclosure.
4. The rack enclosure of claim 1, wherein the plurality of side barriers prevent a mixing of the air and the heated air in the side plenums.

5. The rack enclosure of claim 1, wherein the plurality of side barriers blocks the heated air from flowing in a backward direction and into the plurality of openings.
6. A method of cooling heat-producing components, comprising:
 - directing air into a plurality of perforations formed in front vertical rack columns of a rack enclosure;
 - routing the air through a side plenum located between a rack panel and a chassis, wherein the rack panel is installed between the front vertical rack columns and rear vertical rack columns, and wherein the chassis is mounted in the rack enclosure;
 - channeling the air into a plurality of side openings on a side-surface of the chassis, wherein a plurality of side barriers channel the air into each side opening, and wherein the air is heated in the chassis; and
 - directing the heated air out of a rear side of the rack enclosure.
7. The method of claim 6, wherein the air is directed into a plurality of front perforations formed in a front-face and a front-side face of the front vertical rack columns.
8. The method of claim 6, wherein the plurality of side barriers prevent a mixing of the air and the heated air in the side air plenum.
9. The method of claim 6, flowing the air into the rack enclosure in a front-to-back pattern or a side-to-side pattern.
10. A method comprising,
 - disposing rack panels between vertical rack columns to form a rack enclosure, wherein the vertical columns comprise front vertical rack columns and rear vertical rack columns;

mounting a chassis inside the rack enclosure, wherein the chassis extends a substantial width of the rack enclosure, wherein side plenums are formed between the rack panels and the chassis, and wherein the chassis comprises a plurality of side openings to allow for air flow; and sealing a plurality of side barriers to a side-surface of the chassis to block the air from flowing into a rear side of the rack enclosure.

11. The method of claim 10, wherein the front vertical rack columns comprise a plurality of front perforations extending along a vertical length of the two front vertical rack columns.
12. The method of claim 10, forming the plurality of front perforations on a front-face and a side-face of the two front vertical rack columns.
13. The method of claim 10, wherein the plurality of side barriers are located between one of the front vertical rack columns and one of the rear vertical rack columns and wherein the plurality of side barriers are located behind the plurality of side openings.
14. The method of claim 10, comprising increasing space in the rack enclosure by a range of about 1.0 inches to about 2.0 inches.
15. The method of claim 10, wherein a width of the side plenums between the rack panels and the chassis is about 0.1 inches to about 0.2 inches.

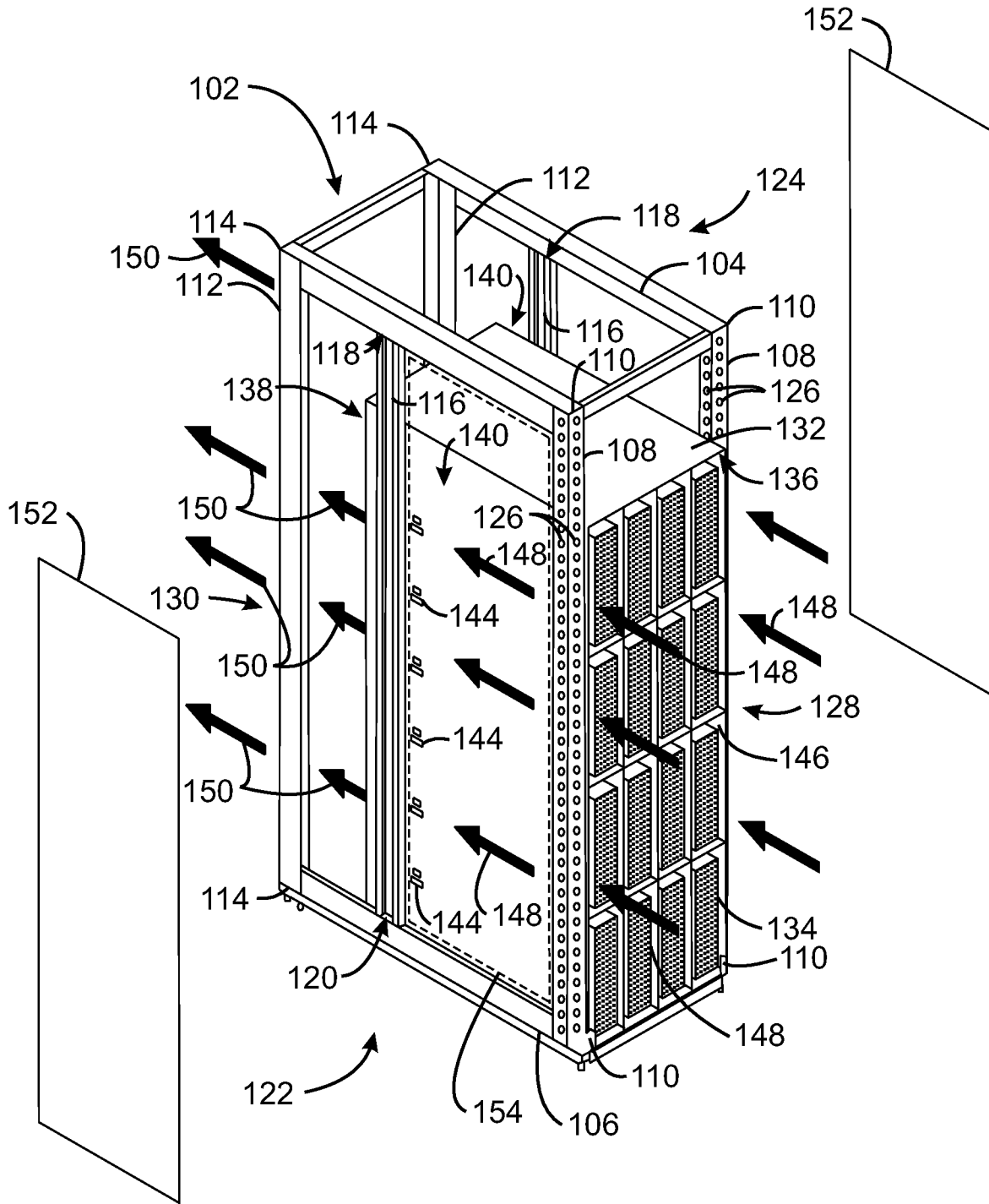

100A
FIG. 1A

2/7

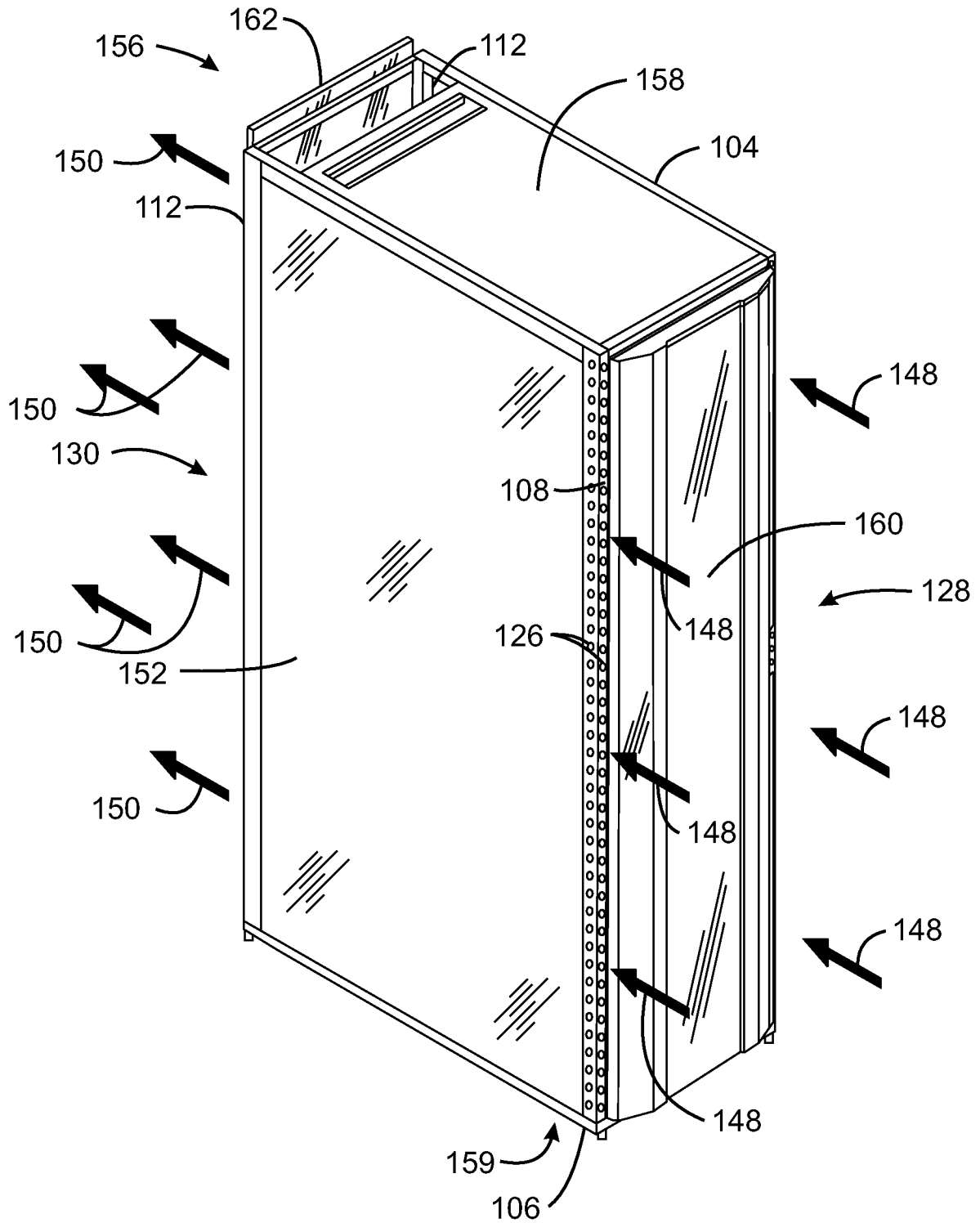

100B
FIG. 1B

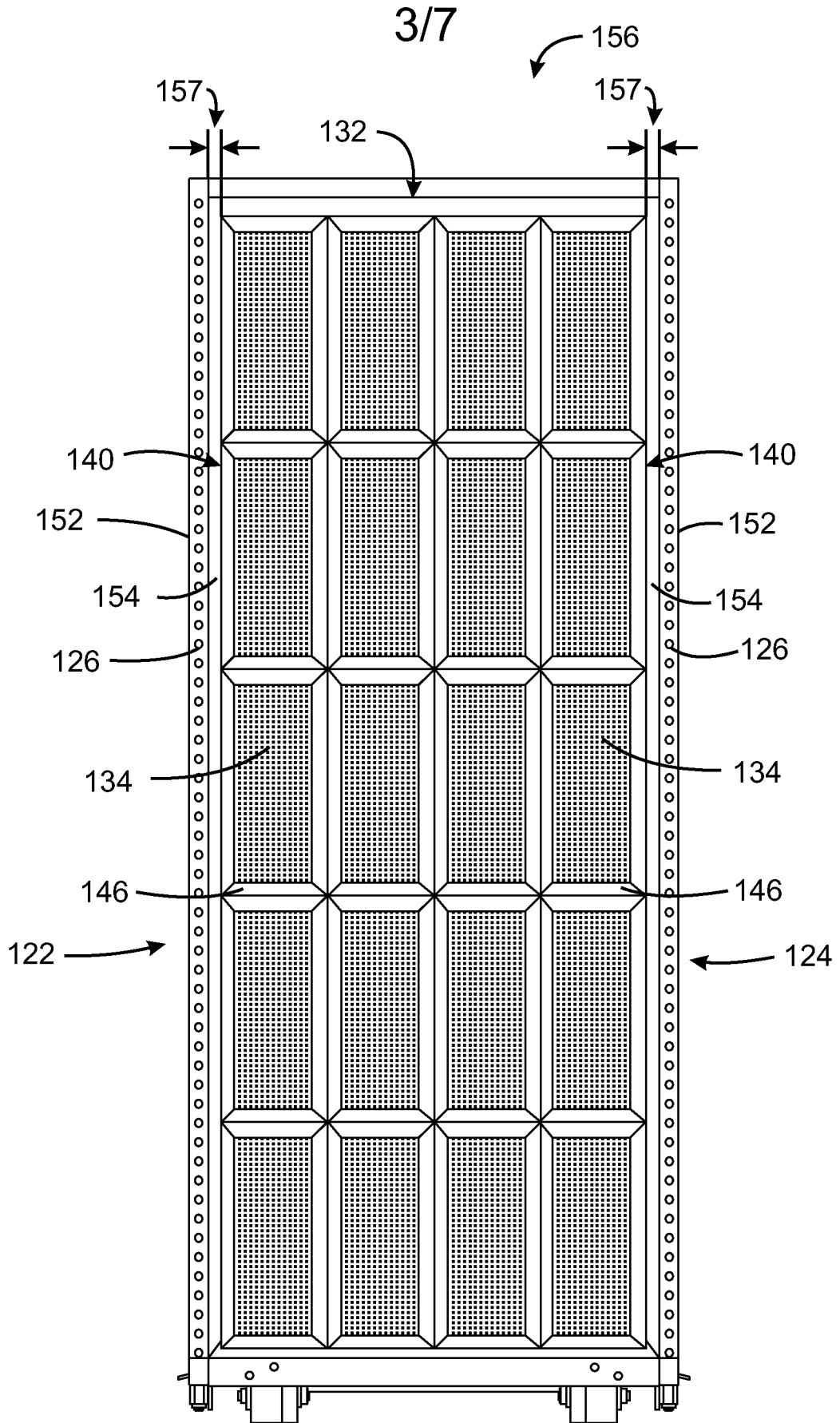

100C
FIG. 1C

4/7

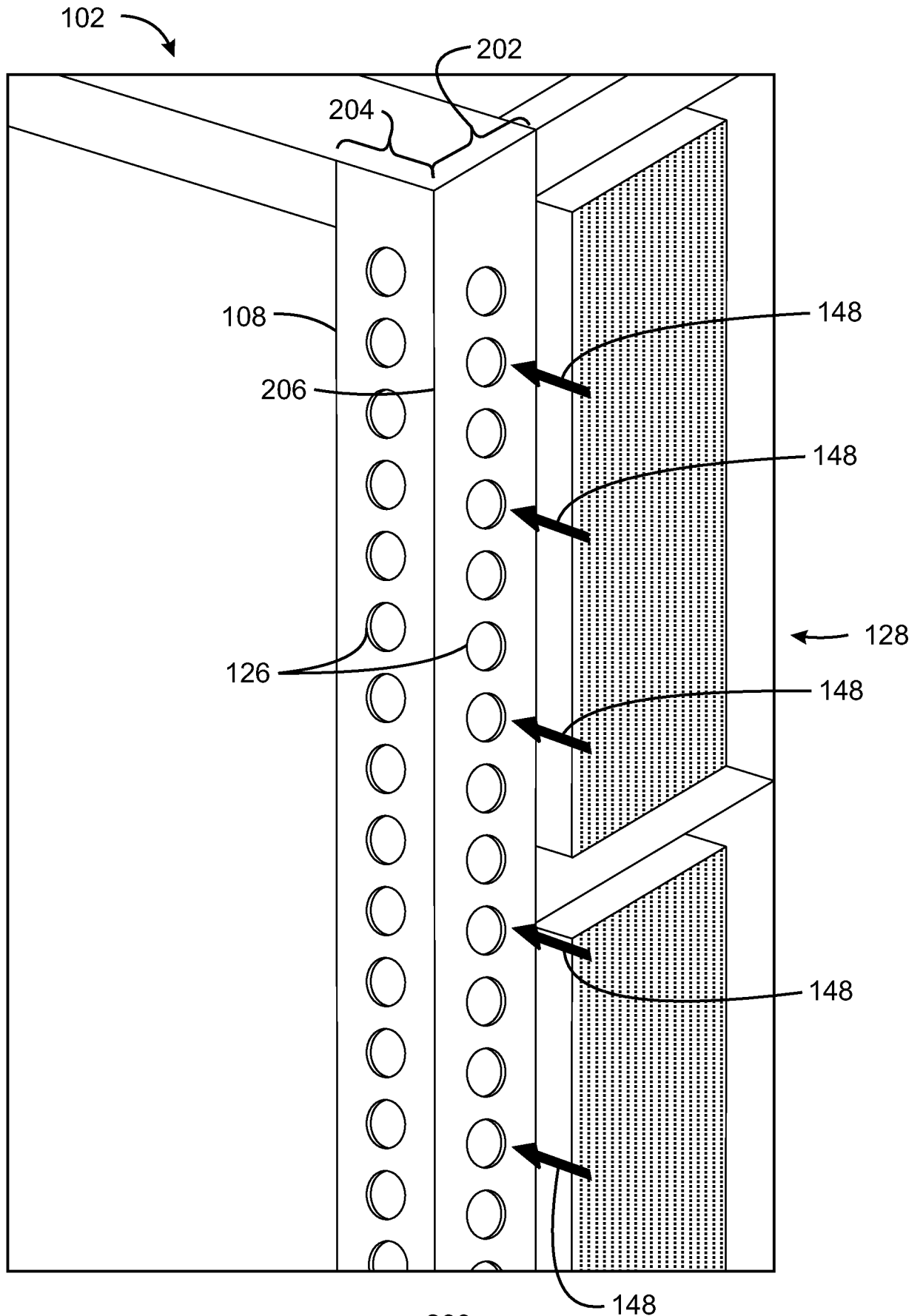

200
FIG. 2

6/7

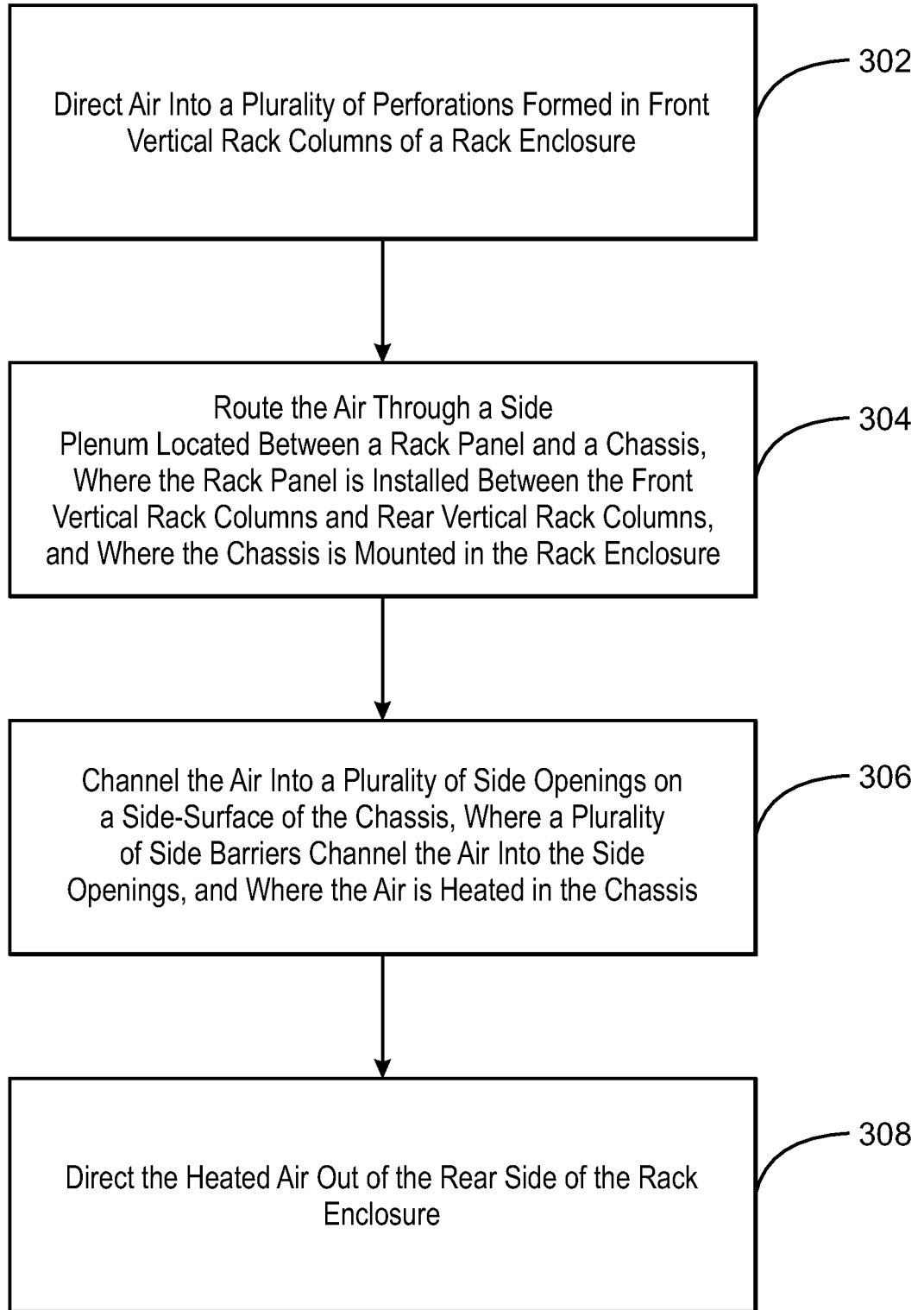

300
FIG. 3

7/7

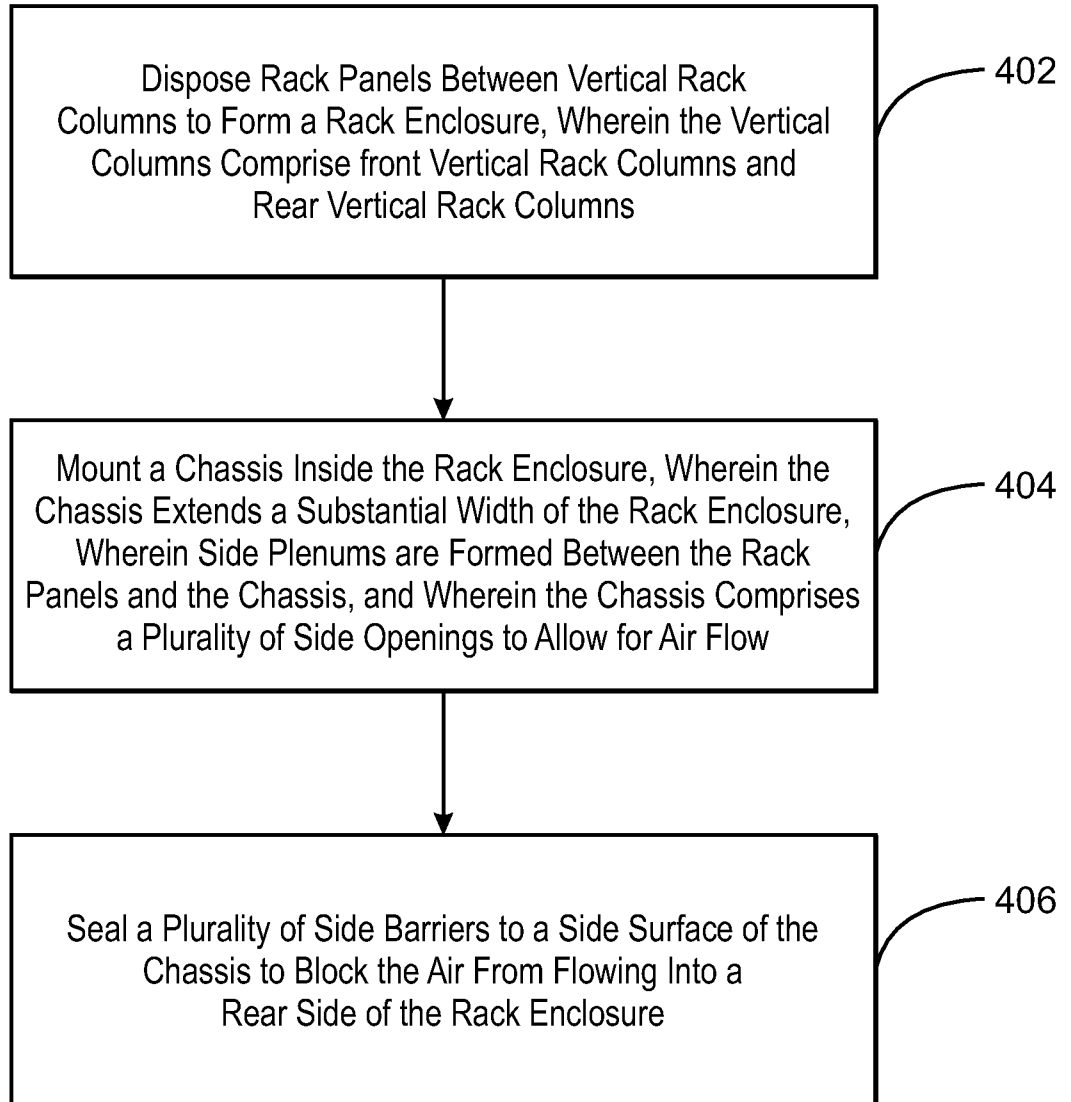

400
FIG. 4

A. CLASSIFICATION OF SUBJECT MATTER**H05K 7/20(2006.01)i, H05K 7/18(2006.01)i**

According to International Patent Classification (IPC) or to both national classification and IPC

B. FIELDS SEARCHEDMinimum documentation searched (classification system followed by classification symbols)
H05K 7/20; H05K 7/18; H02B 1/16; H05K 5/00; F28F 13/00Documentation searched other than minimum documentation to the extent that such documents are included in the fields searched
Korean utility models and applications for utility models
Japanese utility models and applications for utility modelsElectronic data base consulted during the international search (name of data base and, where practicable, search terms used)
eKOMPASS(KIPO internal) & Keywords: rack column, rack panel, perforation, side plenum, side barrier**C. DOCUMENTS CONSIDERED TO BE RELEVANT**

Category*	Citation of document, with indication, where appropriate, of the relevant passages	Relevant to claim No.
Y	US 2006-0276121 A1 (NEIL RASMUSSEN) 07 December 2006 See abstract, paragraphs [0048]-[0093], claims 30,33 and figures 1-2,8A,11-13.	1-15
Y	US 2010-0110633 A1 (YEKUTIEL GIGUSHINSKY) 06 May 2010 See paragraphs [0034]-[0037], claims 1, 19 and figure 1.	1-15
A	JP 2006-140343 A (NIHON FORM SERVICE CO., LTD.) 01 June 2006 See paragraphs [0017]-[0031], claim 1 and figures 1-5.	1-15
A	JP 2010-067628 A (NIHON FORM SERVICE CO., LTD.) 25 March 2010 See paragraphs [0023]-[0033], claim 1 and figures 1-6.	1-15
A	KR 20-0446915 Y1 (CHERIN COOPERATION) 09 December 2009 See paragraphs [0018]-[0036], claim 2 and figures 1-2.	1-15

 Further documents are listed in the continuation of Box C. See patent family annex.

* Special categories of cited documents:

"A" document defining the general state of the art which is not considered to be of particular relevance

"E" earlier application or patent but published on or after the international filing date

"L" document which may throw doubts on priority claim(s) or which is cited to establish the publication date of another citation or other special reason (as specified)

"O" document referring to an oral disclosure, use, exhibition or other means

"P" document published prior to the international filing date but later than the priority date claimed

"T" later document published after the international filing date or priority date and not in conflict with the application but cited to understand the principle or theory underlying the invention

"X" document of particular relevance; the claimed invention cannot be considered novel or cannot be considered to involve an inventive step when the document is taken alone

"Y" document of particular relevance; the claimed invention cannot be considered to involve an inventive step when the document is combined with one or more other such documents, such combination being obvious to a person skilled in the art

"&" document member of the same patent family

Date of the actual completion of the international search

15 January 2016 (15.01.2016)

Date of mailing of the international search report

15 January 2016 (15.01.2016)

Name and mailing address of the ISA/KR



 International Application Division
 Korean Intellectual Property Office
 189 Cheongsu-ro, Seo-gu, Daejeon Metropolitan City, 35208,
 Republic of Korea

Facsimile No. +82-42-472-7140

Authorized officer

KIM, Sung Gon

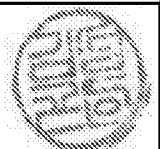
Telephone No. +82-42-481-8746



INTERNATIONAL SEARCH REPORT

Information on patent family members

International application No.

PCT/US2015/026465

Patent document cited in search report	Publication date	Patent family member(s)	Publication date
US 2006-0276121 A1	07/12/2006	AT 524958 T	15/09/2011
		CN 100488346 C	13/05/2009
		CN 101044808 A	26/09/2007
		CN 102088838 A	08/06/2011
		CN 102088838 B	13/11/2013
		CN 1806477 A	19/07/2006
		CN 1806477 B	27/04/2011
		DK 1623611 T3	05/12/2011
		EP 1623611 A2	08/02/2006
		EP 1623611 B1	14/09/2011
		EP 2100490 A1	16/09/2009
		EP 2100490 B1	08/08/2012
		EP 2252136 A2	17/11/2010
		EP 2252136 A3	20/05/2015
		ES 2373384 T3	02/02/2012
		HK 1158878 A1	18/07/2014
		JP 2007-502027 A	01/02/2007
		US 2004-0227435 A1	18/11/2004
		US 2004-0257766 A1	23/12/2004
		US 2007-0129000 A1	07/06/2007
		US 2011-0045759 A1	24/02/2011
		US 7033267 B2	25/04/2006
		US 7112131 B2	26/09/2006
		US 7878888 B2	01/02/2011
		US 8087979 B2	03/01/2012
		US 8403736 B2	26/03/2013
		WO 2004-103046 A2	25/11/2004
		WO 2004-103046 A3	14/07/2005
WO 2005-081607 A1	01/09/2005		
US 2010-0110633 A1	06/05/2010	EP 2156127 A2	24/02/2010
		EP 2156127 B1	26/06/2013
		JP 2010-524074 A	15/07/2010
		WO 2008-122977 A2	16/10/2008
		WO 2008-122977 A3	25/02/2010
JP 2006-140343 A	01/06/2006	JP 4221749 B2	12/02/2009
JP 2010-067628 A	25/03/2010	JP 5136851 B2	06/02/2013
KR 20-0446915 Y1	09/12/2009	KR 20-2009-0005995 U	17/06/2009