

ent in Mechanism for feeding  
Pulverized Fuel to Metallurgic, and other  
Furnaces, and Fireboxes.

Witness  
Edward Benson  
Charles H. Vickerson  
103804

James D. Whelpley }  
Jacob A. Stoner } Inventors

PATENTED MAY 31 1870

Fig. 1.

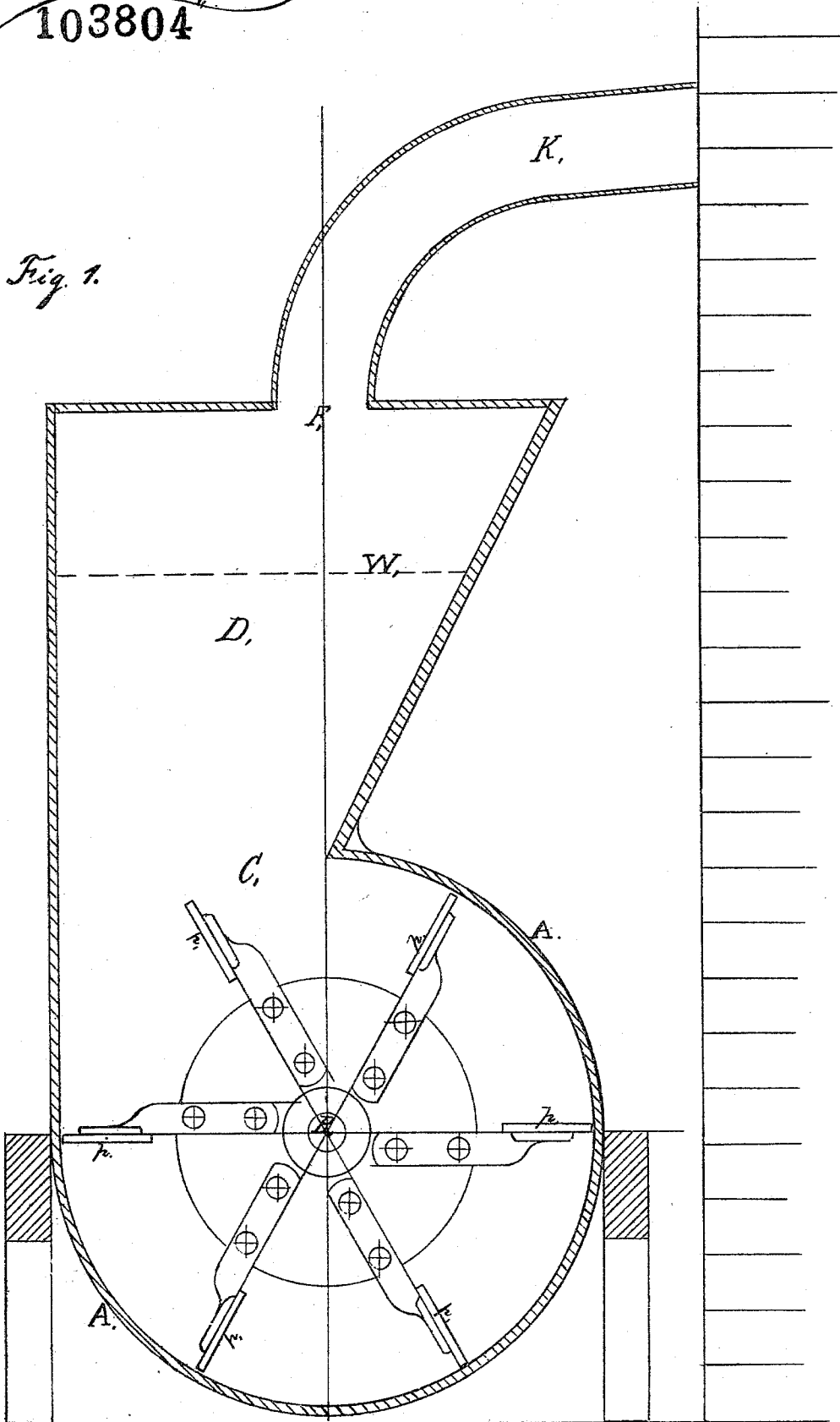

and in Mechanism for feeding  
Pulverized Fuel to Metallurgic and  
other Furnaces, and Fireboxes.

Witness.  
Edward Renouf.  
Charles H. Nickerson

James D. Welpley  
Jacob S. Storer.

Inventors.

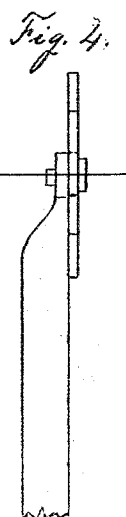
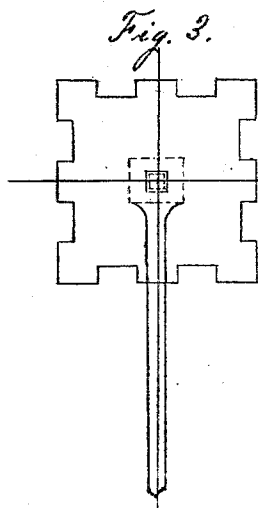
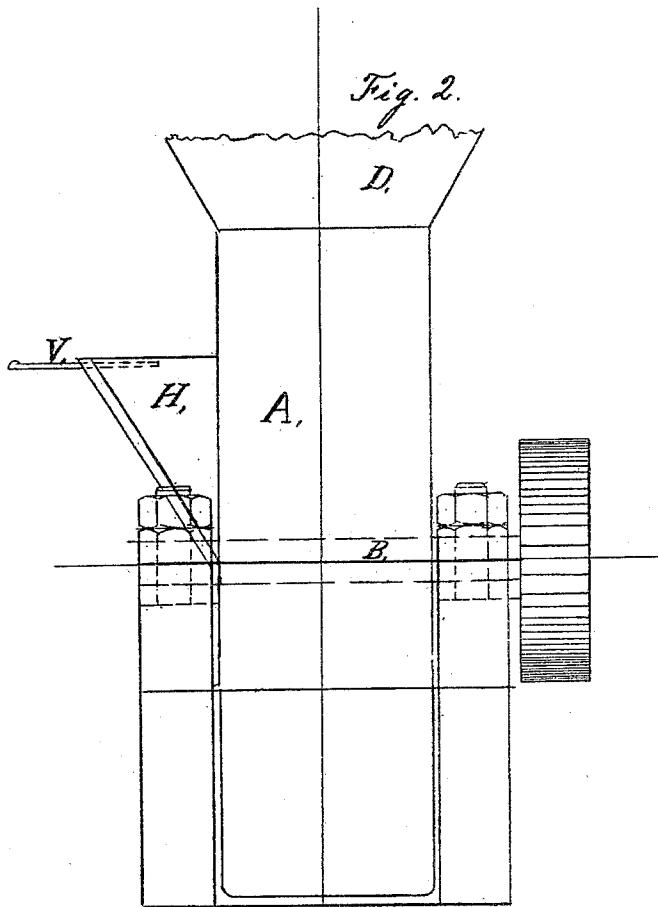

# United States Patent Office.

JAMES DAVENPORT WHELPLEY AND JACOB JONES STORER, OF BOSTON,  
MASSACHUSETTS.

Letters Patent No. 103,804, dated May 31, 1870.

## IMPROVEMENT IN FEEDING PULVERIZED FUEL TO METALLURGIC AND OTHER FURNACES.

The Schedule referred to in these Letters Patent and making part of the same

To all to whom these presents shall come:

Be it known that we, JAMES DAVENPORT WHELPLEY and JACOB JONES STORER, both of Boston, in the State of Massachusetts, have invented an Improvement in Mechanism for Feeding Pulverized Fuel to Metallurgic and other Furnaces and Fire-Boxes, which the following specification and accompanying drawings sufficiently describe.

If broken coal be introduced into a common segmental fan-blower, the revolutions of the fans or paddles will cause it to be reduced to still finer particles, and thrown on a current of air out of the peripheral opening in the fan-case. The diameter of the case and the velocity of the fans will, other conditions being equal, determine the degree of the reduction of the coal, but in any event only a small portion, say, ten to twenty per cent. of the coal ejected, will be fine enough for use in our methods of burning pulverized fuel.

It being desirable to use simple and inexpensive machines for our process, for pulverizing and introducing fuel into fire-boxes, we have adopted among other devices the common segmental fan-blower, with certain modifications and attachments, as shown in the drawings annexed, in order to procure a more thorough pulverization of the material before delivery into the fire-box.

Figure 1 is a vertical section.

Figure 2, an end section.

Figures 3 and 4, an improved form of paddle or fan.

A is the fan-case, representing a segment of a hollow cylinder.

B, the shaft carrying fans or paddles *p p*.

At C is an opening in the periphery of the fan-case.

D is a chamber built over the peripheral opening.

W is a diaphragm of wire-gauze.

F is a hole in the chamber, to which is attached the pipe K, through which the finely-pulverized coal passes to the fire-box.

H is the feed-hopper at the side of the fan-case.

Coal being fed into the hopper falls into the fan-case, and is quickly broken by the revolving fans, and projected on a blast of air into the chamber D. The finely-pulverized coal is carried by the escaping air out of the hole at F, and through the pipe K, while the coarser material falls back into the fan-case by its superior weight, to be again subjected to the action of the fans or paddles.

The feed of air and coal into the fan-case is regulated by a slide or valve, V, or any other analogous arrangement.

This device is new only in its application to the purpose specified.

April 22, 1851, Jehu Hollingsworth patented a

smut-mill and wheat-scourer, which was a segment of a cylinder in which were revolving fans or paddles. This case was open at the top along the whole-length, and a chimney or chamber was fitted close to this opening. His claim was throwing up the grain onto the inclined face of the chimney, fitted to an opening along the top of the concave. The grain to be cleaned was fed into the cylinder and thrown by the paddles against the face of the chimney, whence it returned into the fan-case to be further acted upon, while the dust, smut, &c., were carried by the current of air through the top of the chimney. In Hollingsworth's reissue of October 10, 1854, he says:

"There is a principle involved in the operation of my machine which, to the best of my knowledge, has never before been known or practiced, viz., that of scouring within a cylinder or concave, and throwing the whole mass out of the machine, as it were, when the actual separation takes place, the impurities passing out and the grain returning back again for a similar operation."

This device of Hollingsworth, while it describes the general principles of our machine, and is useful for scouring grain and seeds, is not applicable to the purposes of our invention, viz., to that of simultaneously pulverizing and feeding coal into furnaces and fire-boxes. In fact, the alterations and additions we have made to the machine so essentially modify it as to give it the character of a new machine.

Hollingsworth's machine has large openings in both ends for the admission of air, which openings are covered by wire-gauze to prevent the grain bounding out. In our machine we dispense with these openings, and use only a small opening in one side of the machine near the shaft, two or three inches in diameter, fitted with a hopper and valve for nearly complete closure. The work which we propose to do requires a very small admission of air.

The grain, being fed in at one end of Hollingsworth's machine, is immediately thrown into the chimney by the action of the fan, and, falling back upon an inclined apron, is guided by it again into the cylinder at a point several inches in advance of that of its first entrance, so it is repeatedly thrown out and guided back by the aprons until it reaches the discharging end, whence the last apron guides it into the discharging-hopper. We entirely dispense with these aprons and with the discharging-hopper, desiring all the coarse material fed into our mill to fall back from the chamber, and to be constantly acted upon by the whole length of the paddles until reduced to fine powder; and desiring to have a thing but fine powder finally discharged.

Hollingsworth makes his chimney smaller at the

top than at the bottom, in order, as he says, that the upward blast may be concentrated so as more easily to carry off the dirt and smut, and his fans make but four to five hundred revolutions per minute, the speed of his fans being necessarily slow, for otherwise the grain would be broken and pulverized, the blast of air from his machine must be somewhat faint; hence he requires a conical chimney, in order that the blast may retain sufficient velocity to effect the desired purpose.

For the purpose of pulverizing coal and simultaneously feeding it into fire-boxes, we give our fans a velocity of from eighteen hundred to three thousand revolutions per minute, and instead of making a chimney of the shape of Hollingsworth's, and entirely open at the top, we erect over the opening in the periphery of the fan-case a collecting and returning-chamber, expanding upward, so that the upward current of air shall lose its velocity sufficiently for coarse particles to fall out of it, while the fine dust only shall escape through a small hole in the top or side of the chamber. Sometimes, too, we divide the collecting-chamber into two chambers, by a horizontal diaphragm of wire-gauze, in order to make sure that no particles above a given size shall escape.

Hollingsworth especially claims a roughened interior surface of the fan-case. In our machine, the interior of the pulverizing-chamber must be perfectly smooth. All projections or roughness tend to impair the action of the mill. And we have also devised

other styles than his of fans or paddles. Figs. 3 and 4 show a paddle with equal sides and crenated edges, fastened to the arm by a bolt with square shank or shoulder, fitting into a square or slotted hole in the paddle and arm.

The advantages of this design are threefold: One bolt suffices to keep the paddle in place, so that it cannot turn or swivel, and, as the paddles have four equal edges, we can turn each edge toward the periphery as the others become worn, and the teeth multiply and make more violent the turbines of air created by the revolutions of the fan; and these greatly increase in a given time the percentage of fine pulverization of material.

What we claim, and desire to secure by Letters Patent, is—

1. The use and application of the within-described mechanism for the purposes described.
2. The paddle or fan, with crenated or indented edges, and reversible on a single bolt for pulverizing-fans and mills.
3. The above-described collecting and returning-chamber, expanded upward and covered at the top, and the wire-gauze diaphragm therein, in combination with the cylinder or fan-case, substantially as described.

JAMES D. WHELPLEY.  
JACOB J. STORER.

Witnesses:

EDWARD RENOUF,  
CHARLES M. NICKERSON.