



(19) **United States**

(12) **Patent Application Publication**

**VIKMAN et al.**

(10) **Pub. No.: US 2001/0003401 A1**

(43) **Pub. Date: Jun. 14, 2001**

(54) **METHOD OF BRAKING AN ELECTRICALLY DRIVEN VEHICLE**

(22) Filed: **Oct. 7, 1998**

(75) Inventors: **LEIF VIKMAN, MIOLBY (SE);  
GORAN VALFRIDSSON, MIOLBY (SE)**

(30) **Foreign Application Priority Data**

Oct. 7, 1997 (SE) ..... 9703652

**Publication Classification**

(51) **Int. Cl.<sup>7</sup>** ..... **B60T 13/66**  
(52) **U.S. Cl.** ..... **303/20**

Correspondence Address:

**HAYES SOLOWAY HENNESSEY  
GROSSMAN & HAGE  
175 CANAL STREET  
MANCHESTER, NH 031012335**

**ABSTRACT**

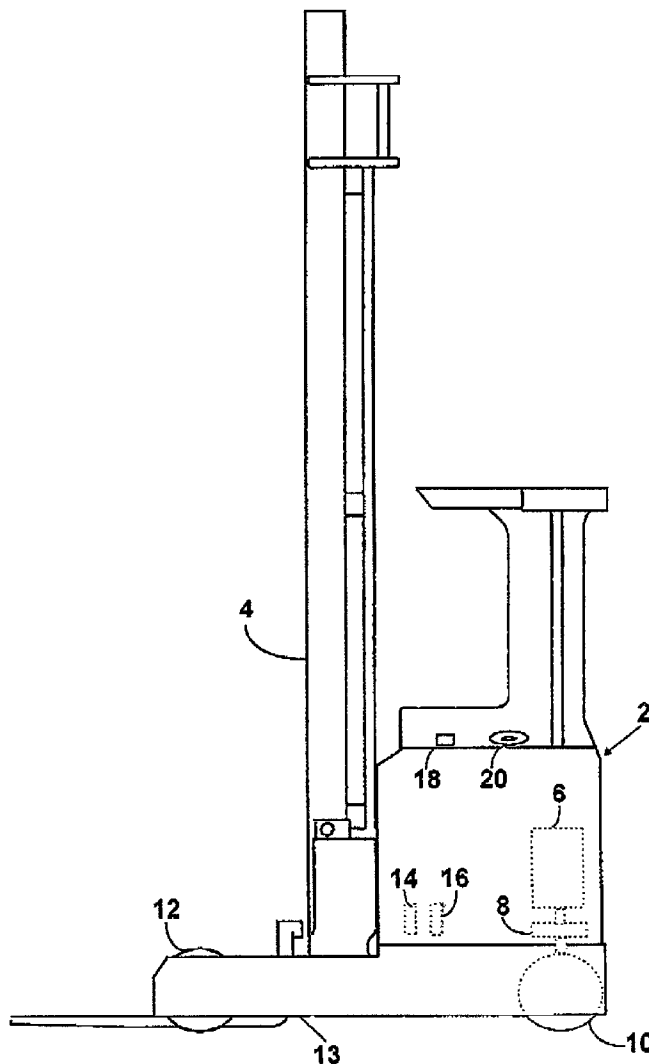
(73) Assignee: **HAYES SOLOWAY HENNESSEY  
GROSSMAN & HAGE**

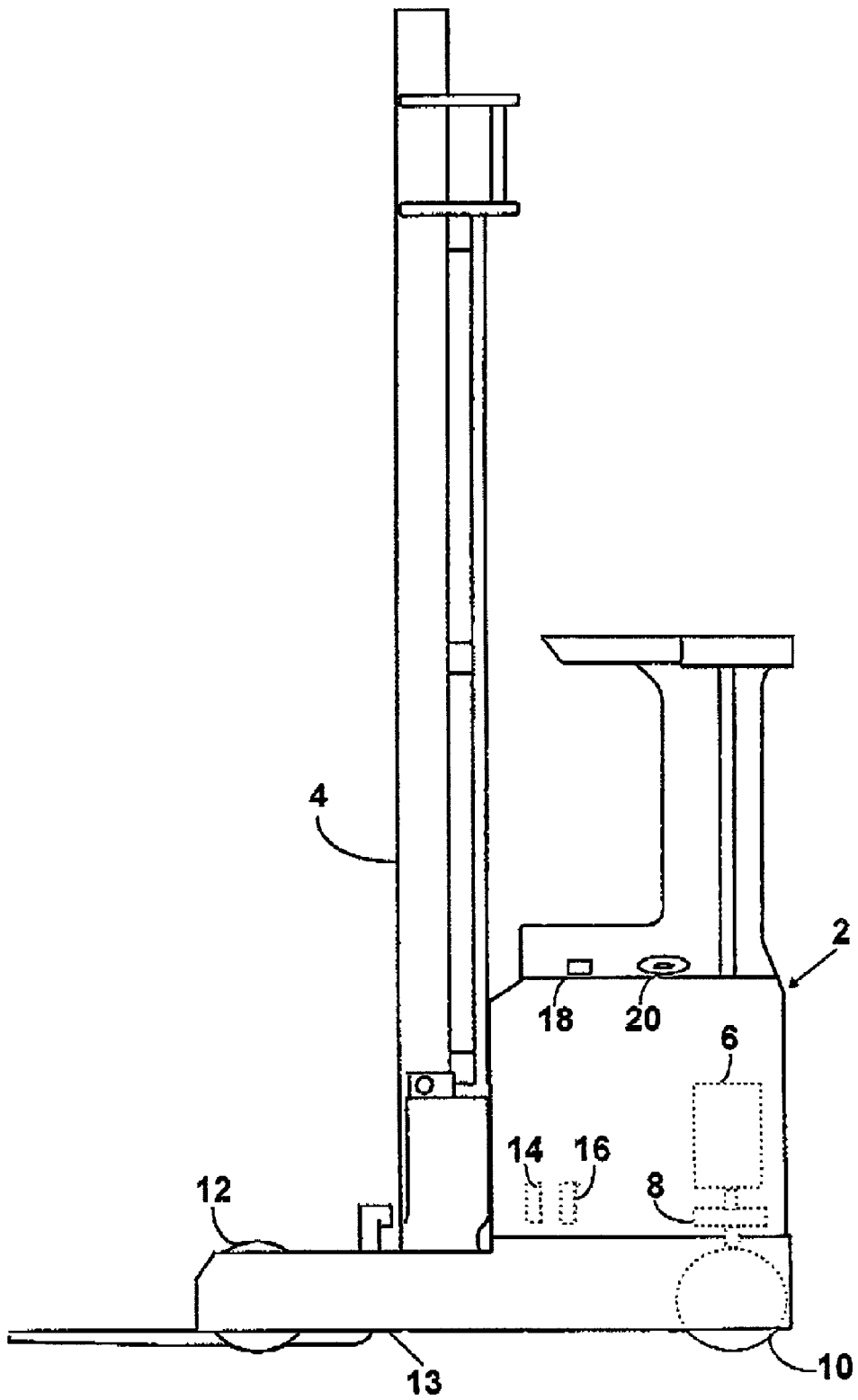
(57)

(\*) Notice: This is a publication of a continued prosecution application (CPA) filed under 37 CFR 1.53(d).

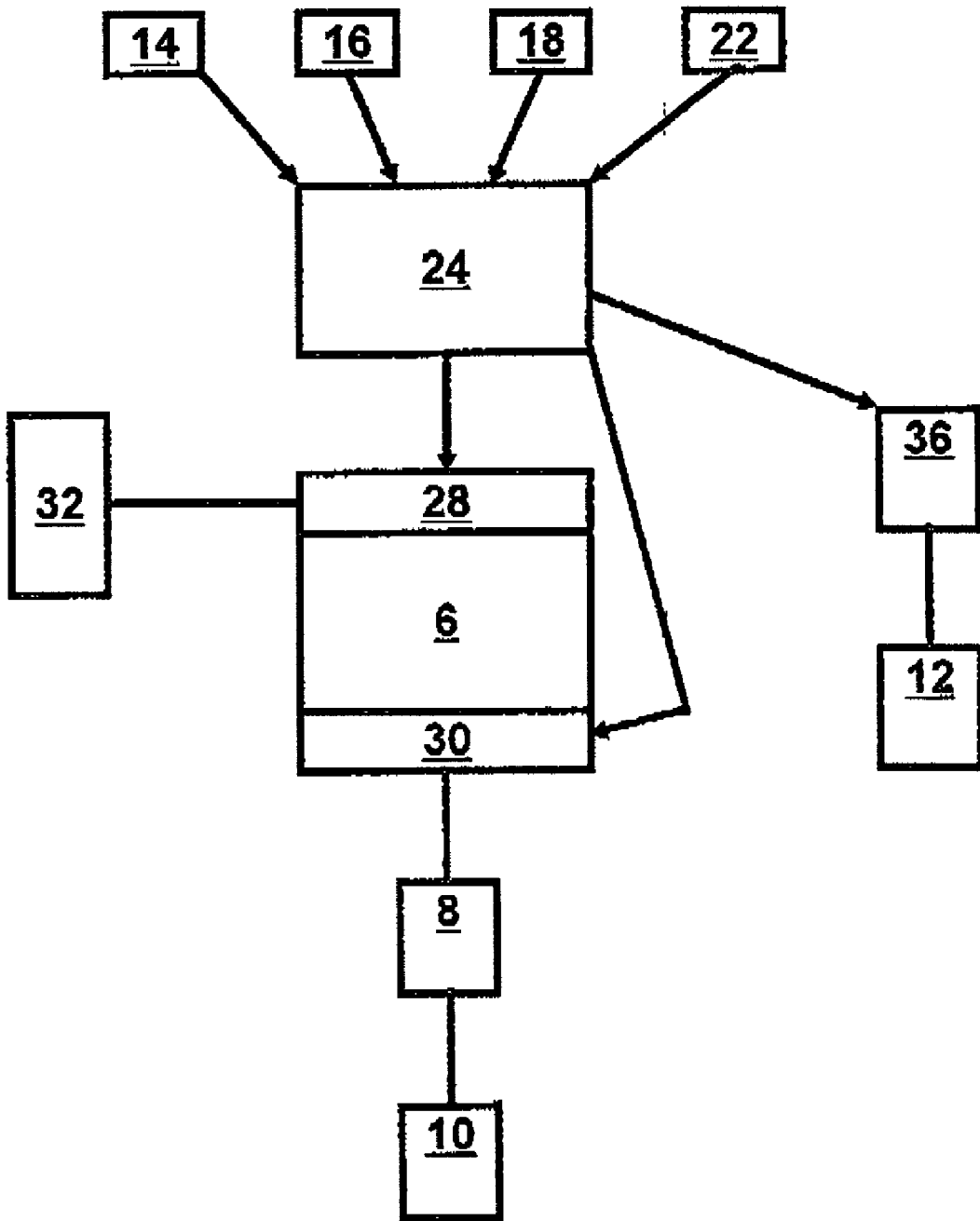
Method of braking a vehicle driven by an electric motor, in particular industrial truck, where the rotational speed of the motor is reduced according to a predetermined deceleration characteristic (a-d) when braking is activated. Preferably the deceleration characteristic is chosen in dependency of the length of depression of a brake pedal.

(21) Appl. No.: **09/168,032**

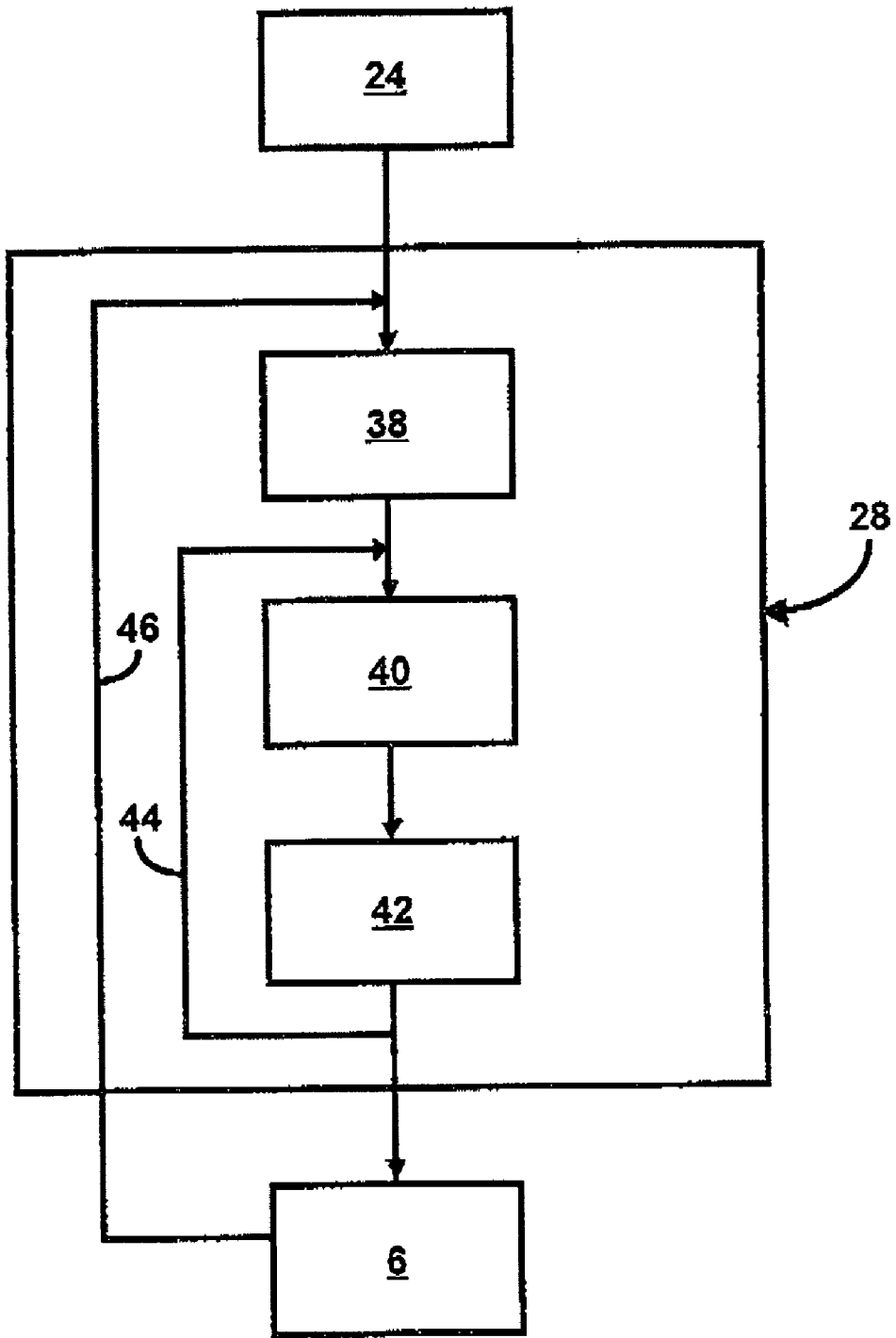




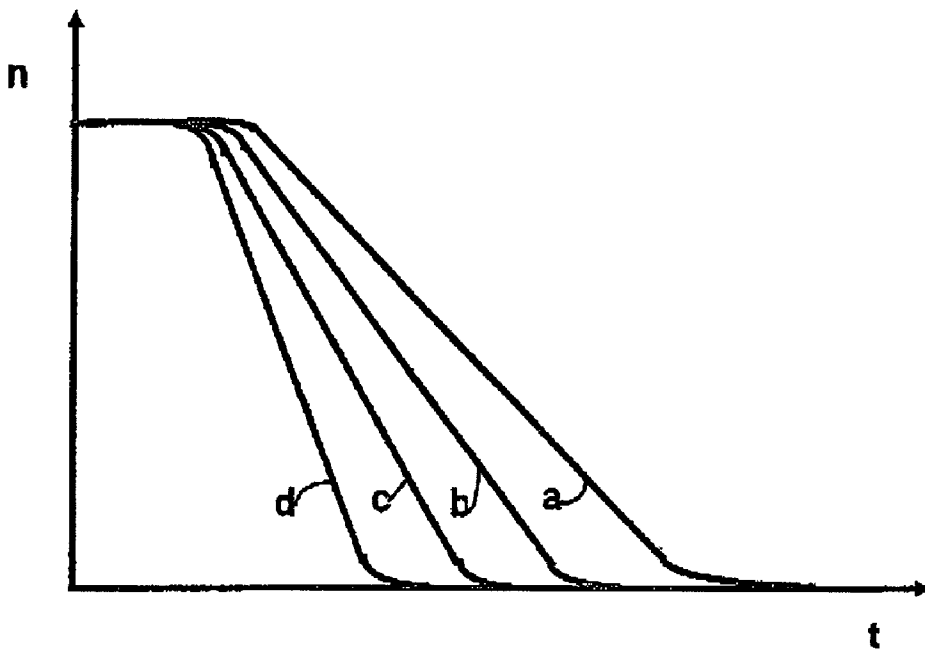
**Fig. 1**



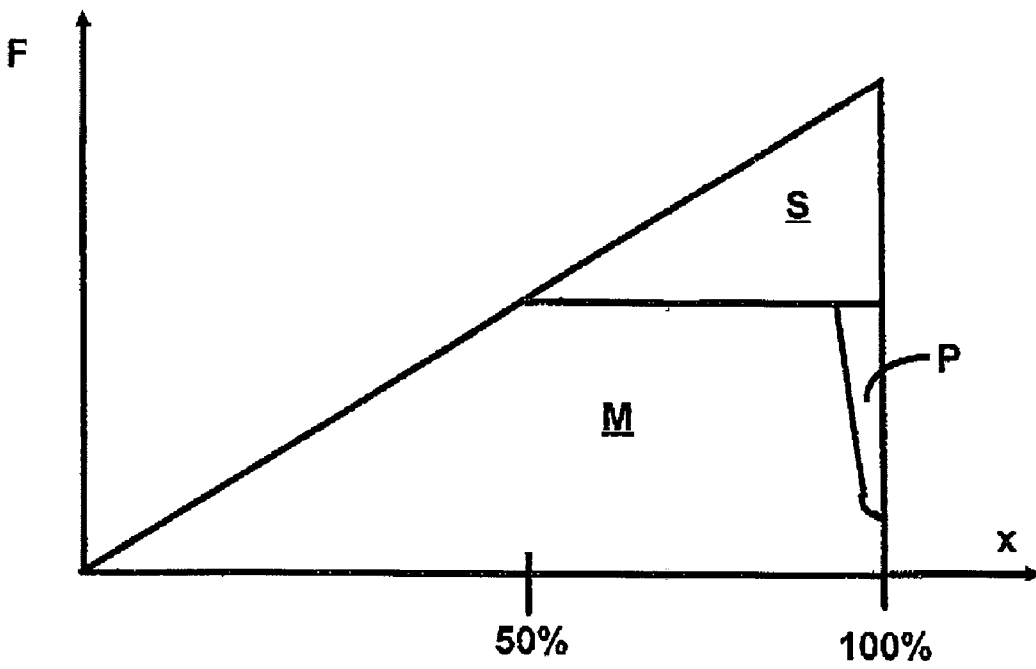
**Fig. 2**



**Fig. 3**



**Fig. 4**



**Fig. 5**

## METHOD OF BRAKING AN ELECTRICALLY DRIVEN VEHICLE

[0001] This invention concerns a method of braking a vehicle driven by an electric motor in accordance with the preamble of claim 1.

### STATE OF THE ART

[0002] The industrial trucks of today that are used indoors are usually provided with an electric motor in the form of a DC-motor driving a drive wheel via a gearbox. The truck is further provided with a number of pivot wheels and/or support wheels.

[0003] The truck is among other things maneuvered by means of a throttle pedal or accelerator that dependent on its position sends signals to an electronic control unit that furthers signals to the control unit of the motor regarding suitable rotational speed for the driving of the truck with the chosen travel speed.

[0004] The truck is further maneuvered with a brake pedal that influence hydraulically controlled mechanical brakes that can influence support wheels as well as drive wheel with suitable torque in dependency of the position of the brake pedal.

[0005] The truck can also be braked by the driver changing a travel direction switch to opposed travel direction, alternatively just releases the accelerator, so called auto-braking, at which the electronic control unit delivers a signal to the motor control unit to brake the engine with a suitable torque.

[0006] These solutions leads to a variation of the brake distance, depending on how heavily loaded the truck is since a heavier load requires greater breaking torque to retain a given break distance.

[0007] Further there is the risk that such a high braking torque is applied that the wheels lock which in addition to longer braking distance also leads to increased wear on wheel as well as gearbox. The wheel also risk becoming locked where the friction is insufficient, e.g. at an oil spot, where it thus will be locked when sufficient friction again exists which can give the mentioned damages. Furthermore this can lead to technical control problems since the control system can get the impression of the truck standing still when the wheel no longer rotates and therefore interrupts the braking which then can lead to serious accidents.

[0008] Regenerative return of braking energy to the battery can only take place at "motor braking" using travel direction switch or released accelerator.

### OBJECT OF THE INVENTION

[0009] The object of the invention is to provide a method to brake an industrial truck where the brake distance is relatively independent of the load of the truck, where maximum brake torque can be limited in order to prevent overloading of tie gearbox, and where the risk of wheel locking is minimized.

### BRIEF STATEMENT OF THE INVENTION

[0010] The object of the invention is achieved with a method in accordance with the characterizing part of claim 1. By controlling the motor so that its rotational speed is reduced according to a predetermined function of the time the deceleration of the motor is thus controlled and therewith also the deceleration of the driving wheel and the track according to a predetermined characteristic. Accordingly a constant brake distance is obtained independent of load since the control unit controls the motor with the braking torque required to give the desired deceleration, where thus the braking torque varies with the load.

[0011] By choosing a suitable characteristic a deceleration can be obtained that at permitted loads gives a braking torque that do not cause damage to the gearbox and minimizes the risk of the wheel becoming locked since it has a rotation speed proportional to that of the motor.

[0012] Regenerative feedback of brake energy to the battery can take place in some known way.

[0013] By using a method according to claim 2 different deceleration characteristics can be used dependent on the activated position of the maneuvering means. Thus the truck can be triggered to a faster braking (greater deceleration) the more the brake pedal is depressed.

[0014] By using a method according to the claims 3 and 4 supplementary brake systems can be triggered when the brake pedal is depressed further than a predetermined position. Hence the motor need only to be fed with the braking current /torque that is required in addition to the braking torque of the supplementary system/systems and a relatively powerful deceleration can be achieved,

[0015] The claims 5 and 6 defines further specified preferred embodiments when applied to industrial trucks, while the claims 7-9 defines embodiments where accelerator and travel direction switch are used as maneuvering means.

[0016] By using a method according to claim 10 the desired vehicle deceleration can be adapted dependent on type of vehicle and driving conditions.

[0017] Further features and advantages of the invention are apparent from the below described preferred embodiment with reference to the enclosed figures.

### LIST OF FIGURES

[0018] FIG. 1 shows a schematic view of a truck.

[0019] FIG. 2 shows schematically the components of the brake system of the truck.

[0020] FIG. 3 shows a more detailed picture of the control unit of the motor according to FIG. 2.

[0021] FIG. 4 shows a diagram of the motor rotational speed  $n$  as a function of the time  $t$  dependant of the brake pedal depression.

[0022] FIG. 5 shows a diagram of the brake force  $F$  as a function of the brake pedal depression  $x$ .

## DESCRIPTION OF AN EMBODIMENT

[0023] The industrial truck **1** shown in FIG. 1 is preferably used indoors and includes as essential parts a chassis **2** to which a mast assembly **4** for the handling of goods is arranged. The truck is driven via an asynchronous motor **6** transferring power to a driving wheel **10** via a gearbox **8**. The truck is further provided with support wheels **12** in the front end of the support arms **13**. The support wheels **12** and the drive wheel **10** can be braked with electromagnetic brakes (not shown in FIG. 1).

[0024] The truck is maneuvered in the usual way with among other things an accelerator **14** and a break pedal **16** whose starting position is define as fully released position. Further there is a travel direction switch **18** and a steering wheel **20**. The components for goods handling are maneuvered in some known manner that does not influence the invention and are therefor not described here.

[0025] At use the driver gives signals to the truck regarding desired travel speed in the usual way by means of the accelerator **14**. When the driver depresses the accelerator **14** a signal is delivered to an electronic control unit **24** that in turn delivers a signal to a motor control unit **28** that control the motor **6**. The signal that is transmitted to the electronic control unit varies dependent on how far the accelerator **14** is depressed and the electronic control unit **24** then delivers a signal to the motor control unit **28** to run the motor with a rotational speed corresponding to the accelerator position.

[0026] More specific this is achieved by the electronic control unit **24** delivering a signal of desired rotational speed to a rotational speed controller **38** in the electronic control unit delivering a signal to a torque controller **40** that via a power controller **42** delivers a current to the motor **6** with an amperage corresponding to suitable torque for the desired rotational speed. The signals are controlled in usual manner by means of feedback **44**, **46** of actual values to the rotational speed controller **38** and the torque controller **40**.

[0027] The braking method according to the invention according to the invention is now described below with reference to the FIGS. 2-5.

[0028] Principally one can say that the driver can brake the track in three different ways by means of different maneuvering means; with the brake pedal **16**, by changing travel direction by means of the travel direction switch **20**, or by releasing the accelerator and letting the truck motor brake. The method for maneuvering with the brake pedal is now described below.

[0029] When the driver depresses the brake pedal **16** a signal is delivered to the motor **6** via is the electronic control unit **24** and the motor control unit **28** to reduce the rotational speed of the motor according to a characteristic with a predetermined deceleration. The deceleration characteristic is preferably constituted of the rotational speed as a function of the time. The controlling is done in a way that corresponds to the above method at accelerating The signal transmitted to the electronic control unit **24** varies dependent of how far the pedal **16** is depressed with more depression giving a steeper characteristic, which thus gives a greater deceleration and thus a more powerful braking. This Is apparent from FIG. 4 where the characteristics a-d show different decelerations dependant of how far the pedal is

depressed, where characteristic d shows the greatest deceleration, that is the most powerful braking.

[0030] Since the driving wheel **10** is connected to the motor **6** via a fixed gear **8** its rotational speed is directly proportional to the motor rotational sped and its brake distance is therefor the same independent of load since the control system will provide the motor with the braking torque that is required.

[0031] By choosing these characteristics in suitable manner it is possible to avoid so powerful torques that the wheel locks at normal friction. In this way the additional damages that otherwise may occur are avoided.

[0032] Since the wheel the entire time rotates with a given speed the properties at temporary slippery places are improved, as for instance small oil spots, Here the wheel of course risks to slip on the ground reducing the deceleration of the truck, but the wheel is not locked entirely but will rotate according to the given characteristic and when sufficient friction exist again the truck continues to decelerate.

[0033] Regeneration of brake energy to the battery **32** of the truck can be achieved in some known manner.

[0034] Cases may occur, in particular with a heavily loaded truck and high initial speed, where only braking through controlling the motor torque as: described above can not provide sufficient brake power to brake the truck according to the desired characteristic. This is of course not desirable from the point of safety since this leads to a longer braking distance.

[0035] This problem is by the invention solved by the following further developed embodiment.

[0036] When the brake pedal is depressed past a first predetermined position, for instance 50% of maximum depression, a supplementary brake system is activated. In this case it is an electromagnetic brake **36** working on the support wheels **12** when an incoming signal is received from the electronic control unit **24**.

[0037] This brake **36** is analogous so that the braking torque increase with increased pedal depression past the mentioned position. The electronic control unit however continue to deliver a signal to the motor control unit **28** to follow the default characteristic a-d, possibly a steeper characteristic is chosen since the pedal depression increases. This results in the rotational speed of the motor following the characteristic according to FIG. 4 and the deceleration and wheel speed follow this independent of the activation of the support wheel brake. The resulting difference is that the motor control unit **28** will adjust to give the motor **6** the braking torque (motor brake) that is required in addition to the torque from the support wheel brake **36**. In FIG. 5 the braking force F as a function of the brake pedal depression x. From this it is apparent that the contribution M from the motor brake cease to increase at 50% depression of the pedal **16** and that the support wheel brake contribute with the remaining part of the required brake torque S. Depending on the type of operation percentage distribution of the contributions may vary some. Thus in some cases the contribution of the motor brake may decrease somewhat when the support wheel brake is activated.

[0038] It is desirable to dimension the controlling so that the motor brake take as large a pan as possible of the brake

energy since only this contribution can be used for regenerative feedback, and to reduce the wear of the supplementary support wheel brake.

[0039] Furthermore additional supplementary brake systems can be activated as the pedal depression continues. According to the preferred embodiment shown here a final digital one step brake **30** is activated just before the pedal **16** reaches its bottom position. This brake subjects the driving wheel to a predetermined braking torque. Owing to this the motor brake only have to contribute with the torque that is required addition to the torques of the one step brake **30** and the support wheel brake **36**. The one step brake is preferably constituted of the same electromagnetic brake that is used as parking brake and its brake contribution is in **FIG. 5** denoted with P.

[0040] In this way the truck braked according to a predetermined deceleration dependent of the degree of pedal depression, but where the electronic control system activates supplementary brake devices in differing degree depending on type of operation so that the predetermined deceleration progress is followed independent of type of operation. The support wheel brake and parking brake are activated first after a predetermine pedal movement so that the motor brake can contribute with as big a part as possible and without the driver actually having to observe that different brake systems are activated. An even and secure brake progress is obtained.

[0041] The brake progress can in the normal way be disrupted before the truck has stopped entirely by the driver releasing the pedal to its initial position.

[0042] According to a further development of the invention the inclinations of the characteristics ad can be set differently depending or type of truck or actual driving conditions. This is preferably achieved by adjustment of a parameter that influence the electronic control unit **24**, the parameter can preferably be changed by a service engineer.

[0043] Braking by means of the travel directions switch **18** is done in principally the same way when the driver signals changed travel direction the motor is braked in the same way by the electronic control unit delivering signals concerning desired deceleration. Also here a number of deceleration characteristics ad corresponding to **FIG. 4** can exist. These are chosen depending the position of the accelerator **14** where a more depressed pedal gives a more powerful deceleration. Adjustment of the parameter **22** is possible here also. At this type of braking however the supplementary brakes **36, 30** are never activated.

[0044] The same principal method is also used at so called auto braking where the truck is braked when the driver ease up the accelerator. Here also the parameter **22** can be changed in order to enable different choice of characteristics Corresponding to **FIG. 4**. In this case the maneuvering means is constituted by the accelerator **14** that activates the braking at release towards inactivated position.

[0045] This further means that auto braking occurs after braking with the brake pedal **16** where this is disrupted by release of the pedal.

[0046] The invention can within the scope of the Patent claims be executed according to other embodiments than those above described. It may for instance be used On other

types of trucks where analogous conditions and problems exist. Furthermore the asynchronous motor can be replaced by some other type of electric motor used at trucks. Furthermore the brake pedal can be replaced by some other maneuvering means, as travel direction switch or accelerator according to the second and third brake method above, or some other type of known maneuvering means even if the mentioned ones are to be preferred since they are well tested and safe designs.

[0047] According to the embodiment the predetermined deceleration characteristics have the rotation speed of the motor as a function of time, which is suitable choice. It may also be possible to control according to other parameters that give a deceleration controlled braking, as vehicle speed or distance.

1. Method of braking a vehicle driven by an electric motor, where the vehicle drive wheel (**10**) rotational speed is proportional to the rotational speed of the electric motor (**6**), characterized in that a vehicle driver activates a maneuvering means (**14, 16, 18**) at which an electronic control unit sends signals to a control unit (**28**) of the electric motor to reduce the rotational speed of the motor according to a predetermined deceleration characteristic (a-d).

2. Method according to claim 1 where the maneuvering means (**16**) can be activated to a number of different activation positions, preferably, in the form of a brake pedal, characterized in the rotational speed of the electric motor (**6**) being reduced during the time the maneuvering means (**16**) is activated according to one of a number of available predetermined deceleration characteristics (a-d) where the characteristic (a-d) is chosen in dependency of the activation position of the maneuvering means (**16**) so that the rotational speed is reduced more rapidly the further the maneuvering means (**16**) is brought from its initial position.

3. Method according to claim 1 or 2 where the maneuvering means **16** can be activated to a number of different activation positions, characterized in that when the driver activates the maneuvering means (**16**) past a first position a supplementary brake device (**36**) is activated that influence one or more vehicle wheels (**12**) with a braking torque, the control unit (**28**) of the electric motor feeding the motor the current/torque that is required for the motor rotational speed to correspond the deceleration characteristic (ad) in question.

4. Method according to claim 3, characterized in that a number of supplementary brake devices (**36, 30**) are activated when the maneuvering means (**16**) pass a for respective brake device corresponding position, the electric motor control unit (**28**) feeding the motor (**6**) the current required for the rotational speed of the motor to correspond to the current deceleration characteristic (a-d).

5. Method according to any of the preceding claims, characterized in the method being used on an industrial truck with an asynchronous motor (**6**) where the maneuvering means (**16**) is constituted by a brake pedal.

6. Method according to claim 5, characterized in that when the maneuvering means (**16**) pass a first position an electromagnetic brake (**36**) is activated working on support wheels (**12**) arranged in support arms (**13**) of the truck, and when the maneuvering means (**16**) pass a second position close to its mechanical end position an electromagnetic brake (**30**) is activated working directly or indirectly on the driving wheel (**10**).

7. Method according to claim 1, characterized: in the driver activating a travel direction switch (18), in particular in an industrial truck.

8. Method according to claim 7, characterized in that the rotational speed of the electric motor (6) is reduced according to one of a number of available predetermined deceleration characteristics (a-d), where the characteristic (a-d) is chosen in dependency of the activation position of an accelerator (14) so that the rotational speed is reduced quicker farther the pedal is from its initial position.

9. Method according to claim 1, characterized in that the driver activates an accelerator (14), in particular an industrial truck, by release towards an initial position.

10. Method according to any of the preceding claims, characterized in that one or several available predetermined deceleration characteristics (a-d) can be varied by adjustment of a parameter influencing the electronic control unit (24).

\* \* \* \* \*