

Dec. 19, 1939.

C. L. MILER

2,184,050

BRAKE

Original Filed Nov. 30, 1937

2 Sheets—Sheet 1

Fig. 1.

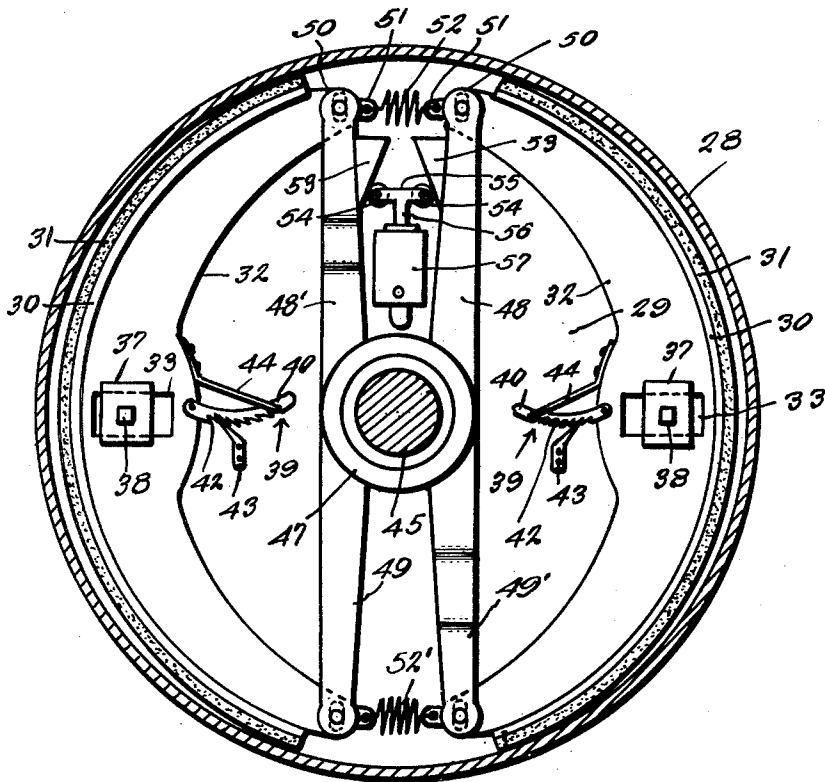
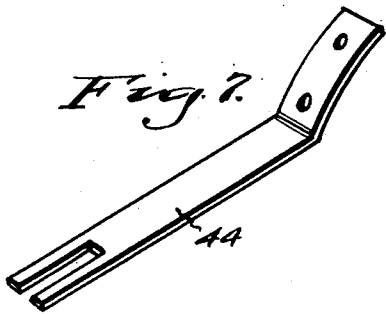

Fig. 6.



Fig. 7.



Inventor

Clyde L. Miler

By

Clarence A. Orion
and Hyman Berman
Attorneys

Dec. 19, 1939.

C. L. MILER

2,184,050

BRAKE

Original Filed Nov. 30, 1937

2 Sheets-Sheet 2

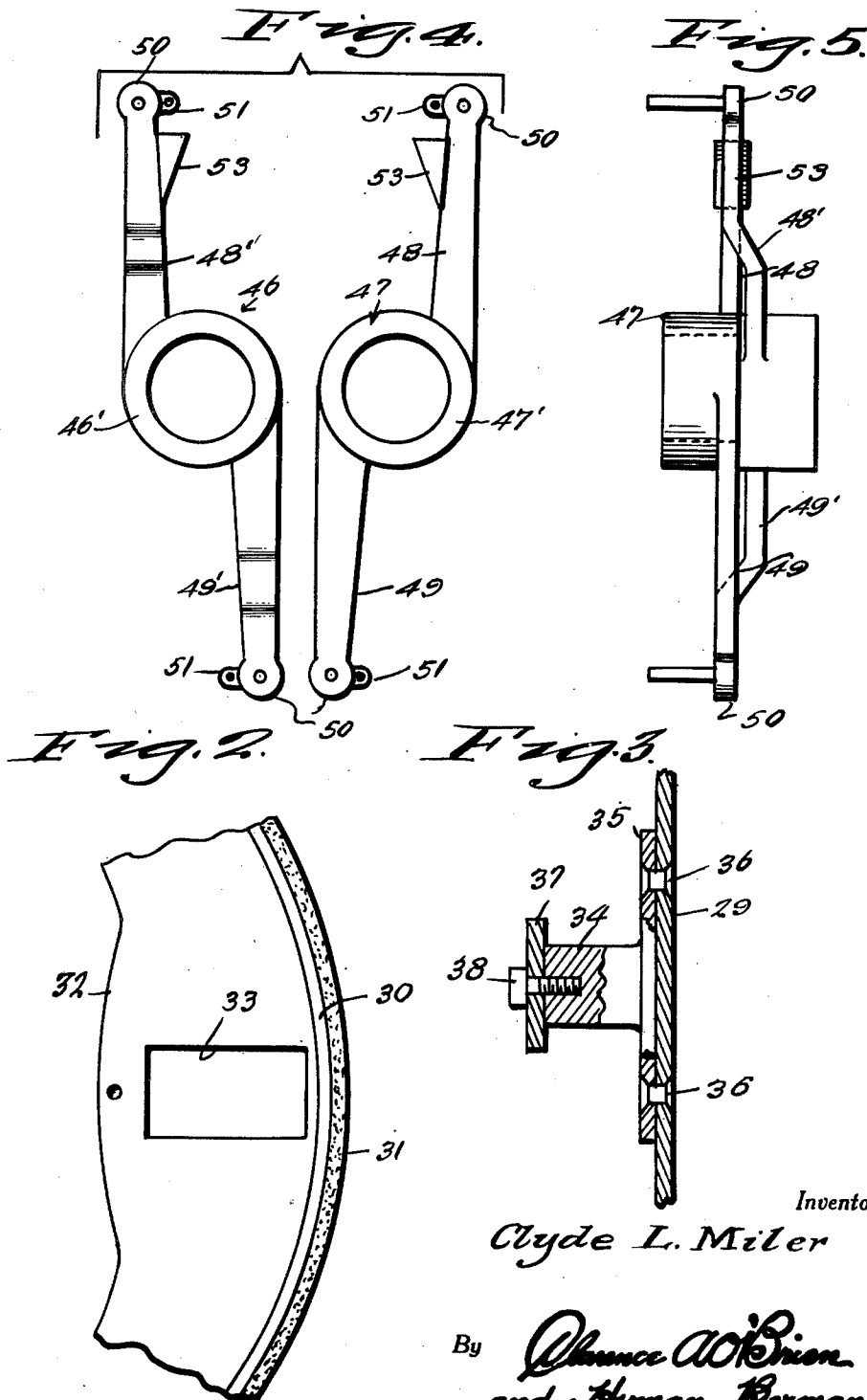

Inventor

Clyde L. Miler

By *Oliver A. O'Brien*
and Hyman Berman
Attorneys

UNITED STATES PATENT OFFICE

2,184,050

BRAKE

Clyde L. Miller, Rock Rapids, Iowa

Original application November 30, 1937, Serial No. 177,297. Divided and this application March 15, 1938, Serial No. 196,065

1 Claim. (Cl. 188—78)

This invention appertains to new and useful improvements in brakes and more particularly to brakes especially adapted for use on automobiles, the same being a division of my co-pending application Serial No. 177,297, filed November 30, 1937.

An important object of the invention is to provide a brake construction wherein the shoes will be uniformly worn and wherein wear will be automatically compensated for, by simple and positive acting means.

Other important objects and advantages of the invention will become apparent to the reader of the following specification.

In the drawings:

Figure 1 represents a vertical sectional view through the brake structure.

Figure 2 is a fragmentary side elevational view of one of the shoes.

Figure 3 is a fragmentary detailed sectional view through one of the guides.

Figure 4 is a side elevational view of the pair of rockable arms.

Figure 5 is an edge elevational view of one of the rockable arms.

Figure 6 is a side elevational view of the ratchet arm.

Figure 7 is a perspective view of the guide arm for the ratchet arm.

Referring to the drawings wherein like numerals designate like parts it can be seen that the improved brake structure consists of the drum 28 having the usual fixed vertical wall 29 or dust shield associated therewith and against this drum 28 is operative the pair of arcuate-shaped shoes 30—30 on which are the linings 31—31. Each of these shoes is provided with the web structure 32 slotted as at 33 for receiving the guide boss 34 projecting from the plate 35 secured as by riveting 36 to the wall or the dust shield 29. The boss 34 is preferably of polygonal cross section to provide flat surfaces against which the webs 32 at the edge portions of their openings 33 can ride. To prevent displacement of the shoes, stop plates 37 are secured as at 38 to the bosses 34.

Wear compensating means generally referred to by numeral 39 is provided for each of the shoes 30 and this consists of an arcuate-shaped arm 40 pivotally secured as at 41 to the corresponding web 32 with the obliquely set teeth 42 riding against the obliquely set tooth 43 which is suitably secured to the wall or dust shield 29. A strip spring 44 having its upper end suitably secured to the corresponding web 32, has its

lower end bifurcated for engagement over the free end portion of the arm 40. Obviously, as wear occurs in the lining 31 of the shoe, this wear will be taken up by shifting of the arm 40 over the tooth 43.

To afford uniform action of the shoes 30—30, the axle spindle 45 has rockable units 46 and 47 mounted thereon. The unit 47 includes a hub 47' and is provided with oppositely extending arms 48 and 49 and the unit 46 includes a hub 46' provided with oppositely extending arms 48' and 49'. Said arms at the free ends thereof are provided with heads 50 and apertured ears 51. The ears 51 of the arms 48 and 48' are connected by a contractable spring 52 while the arms 49 15 and 49' are connected by a contractable spring 52'. One of the shoes has the arm 48 pivoted to one end thereof and the other end thereof has the arm 49' pivoted thereto. The other shoe has the arm 48' pivoted to one end thereof and the other end thereof has the arm 49 pivoted thereto. The arms 48 and 48' are equipped with opposed wedge-shaped blocks 53 engaged by rollers 54 of a spreader 55 forming a part of a plunger rod 56 of a plunger which operates in a brake cylinder 57. The units 46 and 47 thus connected to the shoes when the arms 48 and 48' thereof are spread apart by the spreader 55 will bring about moving of the shoes into engagement with the brake drums evenly throughout the length of said shoes to assure uniform wear of the linings thereof.

The arms 48' and 49' have a limited curvature thereto for positioning said arms in a plane of the arms 48 and 49, consequently positioning the blocks 53 opposite to each other.

While the foregoing specification sets forth the invention in specific terms, it is to be understood that numerous changes in the shape, size and materials may be resorted to without departing from the spirit and scope of the invention as claimed hereinafter.

Having described the invention, what is claimed as new is:

In a brake construction, opposed brake shoes 45 mounted intermediate the ends thereof for sliding movement towards and from a brake drum, rotatably mounted hubs arranged between said shoes intermediate the ends of the latter, oppositely extending arms formed on each of said hubs and one arm of one hub being pivotally connected to an end of one of the brake shoes and the other arm of said latter-named hub being pivotally connected to an end of the other shoe and one arm of the other hub being pivotally

connected to one end of one of the shoes and the other arm of the latter-named hub being pivotally connected to an end of the other shoe, opposed tapered blocks and one of said blocks being
5 formed on one of the arms of one of the hubs and the other block being formed on one of the

arms of the other hub, contractable springs connecting the adjacent ends of the arms together, and a spreader coacting with the blocks to pivot said arms for engaging the shoes with the drum.

CLYDE L. MILER.