



- (51) International Patent Classification:
B63J 2/08 (2006.01) *F24F 11/00* (2006.01)
B60H 1/00 (2006.01)
- (21) International Application Number:
PCT/DK2013/000034
- (22) International Filing Date:
16 May 2013 (16.05.2013)
- (25) Filing Language: English
- (26) Publication Language: English
- (30) Priority Data:
PA 2012 00370 29 May 2012 (29.05.2012) DK
- (71) Applicant: DANFOSS IXA A/S [DK/DK]; Ulvehavevej 61, DK-7100 Vejle (DK).
- (72) Inventors: STOLBERG-ROHR, Thomine; Odinsgade 50 T, DK-7100 Vejle (DK). MOOS, Henrik Gedde; Vestergade 89, DK-5500 Middelfart (DK). HANSEN, John Skou; Kragelundvej 149, DK-7080 Boerkop (DK). KRISHNA, Sitaraman, Arun; Langlaervej 19,mf, DK-8381 Tilst (DK). JENSEN, Jens Moeller; Nordrevej 11, DK-8700 Horsens (DK).
- (74) Agent: DANFOSS A/S; Intellectual Property, L25, Nordborgvej 81, DK-6430 Nordborg (DK).

(81) Designated States (unless otherwise indicated, for every kind of national protection available): AE, AG, AL, AM, AO, AT, AU, AZ, BA, BB, BG, BH, BN, BR, BW, BY, BZ, CA, CH, CL, CN, CO, CR, CU, CZ, DE, DK, DM, DO, DZ, EC, EE, EG, ES, FI, GB, GD, GE, GH, GM, GT, HN, HR, HU, ID, IL, IN, IS, JP, KE, KG, KM, KN, KP, KR, KZ, LA, LC, LK, LR, LS, LT, LU, LY, MA, MD, ME, MG, MK, MN, MW, MX, MY, MZ, NA, NG, NI, NO, NZ, OM, PA, PE, PG, PH, PL, PT, QA, RO, RS, RU, RW, SC, SD, SE, SG, SK, SL, SM, ST, SV, SY, TH, TJ, TM, TN, TR, TT, TZ, UA, UG, US, UZ, VC, VN, ZA, ZM, ZW.

(84) Designated States (unless otherwise indicated, for every kind of regional protection available): ARIPO (BW, GH, GM, KE, LR, LS, MW, MZ, NA, RW, SD, SL, SZ, TZ, UG, ZM, ZW), Eurasian (AM, AZ, BY, KG, KZ, RU, TJ, TM), European (AL, AT, BE, BG, CH, CY, CZ, DE, DK, EE, ES, FI, FR, GB, GR, HR, HU, IE, IS, IT, LT, LU, LV, MC, MK, MT, NL, NO, PL, PT, RO, RS, SE, SI, SK, SM, TR), OAPI (BF, BJ, CF, CG, CI, CM, GA, GN, GQ, GW, ML, MR, NE, SN, TD, TG).

Published:
— with international search report (Art. 21(3))

(54) Title: DYNAMIC VENTILATION CONTROL SYSTEM FOR REEFER CARGO HOLDS

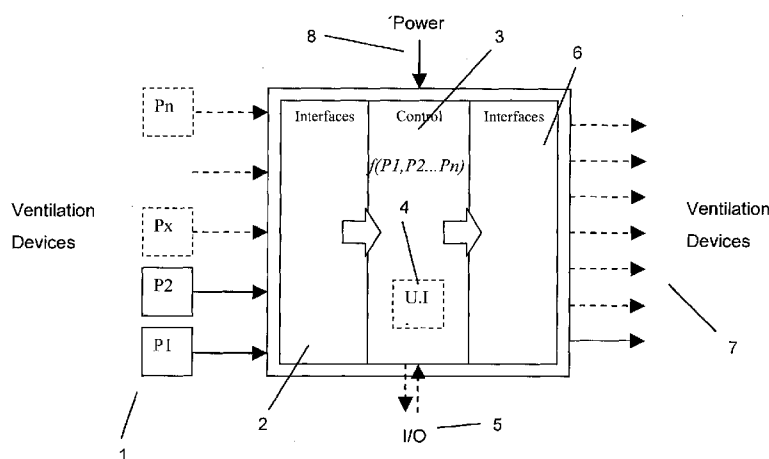

Fig. 1

(57) Abstract: The invention relates to control of the ventilation in vessel cargo holds carrying e.g. reefer containers. The purpose of the invention is to optimize the overall energy consumption related thereto, i.e. minimizing the total energy consumed by the cargo hold ventilation and cargo carrying units, in particular but not limited to reefer containers, in the ventilated cargo hold or holds. The invention continuously or with intervals measures a number of physical parameters, e.g. temperatures, related to the cargo hold or holds and to the ambient conditions, and utilizes the measurement results to establish one or more control signals to directly or indirectly control the ventilation of the cargo hold or holds in such way that the total energy consumption of the ventilation and the cargo carrying units is dynamically minimized as conditions change.

WO 2013/178227 A1

Dynamic Ventilation Control System for Reefer Cargo Holds

Background of the invention

5 There is an ever changing demand for ventilation in a cargo hold that carries reefer containers. Parameters like capacity utilization, Reefer container make, model, age and maintenance status, day/night changes, weather conditions, water temperatures, load patterns, cargo properties etc. all influence the ventilation rate requirement and makes it impossible to predict the ventilation
10 demand without a systematic and knowledge based approach. Without, the result is that the ventilation is run either too high or too low; in either case energy is lost either in the reefer containers, their supporting systems, or in the cargo hold ventilation itself. The optimum ventilation rate for minimized energy consumption changes dynamically along with the aforementioned multiple
15 parameters and thus the total energy optimum ventilation rate of the cargo hold cannot be predicted by simple lookup tables etc. nor obtained by manual control, but requires continuous control based on knowledge of the multiple parameters, the impact thereof on the overall energy performance, and on supporting parameter measurements. No such dedicated control system exists
20 today.

Control systems for ventilation readily exist that perform a demand based control of a ventilation rate. Such control systems are common in modern HVAC installations etc. However, existing systems all serve to create maintain a
25 specified condition in a space or volume. The present invention differs from prior art in that it does not serve to maintain a specified absolute condition, defined by a number of related parameters, e.g. temperature and humidity, in a space or volume, but serves to create and uphold a specific relative condition, defined by a number of parameters, e.g. temperature and humidity and CO2
30 concentration, the condition being relative to the consolidated analytic interpretation of the aforementioned multiple parameters.

Summary of the system

The invention relates to control of the ventilation in vessel cargo holds, in particular, but not limited to, seagoing vessel cargo holds carrying reefer
5 containers. In such a cargo space typically a plural of reefer containers usually will be transported such as hundreds or even thousands where they often operate at different conditions meaning each separate reefer container often require to be maintained at different internal conditions such as temperature. The purpose of the invention is to optimize the overall energy consumption
10 related thereto, i.e. minimizing the total energy consumed by the cargo hold ventilation and cargo carrying units present, in particular but not limited to reefer containers, in the ventilated cargo hold or holds at any time.

The invention continuously or with intervals measures a number of physical
15 parameters, e.g. temperatures and relevant gas concentrations, related to the immediate conditions in the cargo hold or holds and to the ambient conditions, and utilizes the measurement results to establish one or more control signals to directly or indirectly control the ventilation of the cargo hold or holds in such way that the total energy consumption of the ventilation and the cargo carrying units
20 is dynamically minimized as conditions change.

The present invention more generally relates to a cargo to be maintained at some condition such as but not limited to at or below some temperature set
25 point, where the cargo is positioned in some confined area, such as the cargo space of a vessel such as, but not limited to, a cargo ship. The cargo space has some internal conditions such as cargo hold temperature, cargo humidity, cargo air composition etc., these being the conditions inside the cargo space. Outside the cargo space some ambient conditions prevails such ambient temperature, ambient humidity, ambient air composition etc., where outside may be just
30 outside the cargo space but still within the vessel itself, or may even be external to the vessel. Inside the reefer container in the same manner prevails the container conditions such as container temperature, container humidity, container air composition etc.

The container conditions, especially the container temperature within the reefer container itself, require energy to be maintained within some given limits, where this energy is related the cargo conditions such as cargo hold temperature. As
5 also given above, in a cargo space typically carrying hundreds or even thousands reefer containers where each separate reefer container often require to be maintained at different internal conditions such as temperature. The task therefore is to ensure the conditions is such that the reefer containers may operate at the desired container conditions but a minimum of overall energy
10 consumption.

It has been observed that this may be realized by controlling the cargo conditions, being the internal conditions in the cargo space but external to the reefer containers, in a manner where they depend on the external conditions by
15 some relation, where this relation in one simple embodiment is to keep the temperature difference between the cargo hold temperature and the ambient temperature substantially constant., In the main but not limiting embodiment of the present invention the cargo hold temperature is ventilated such that the difference between the cargo hold temperature and ambient temperature is
20 maintained at a substantially constant difference, at least in a simple embodiment of the present invention.

The ambient temperature and other parameters may be measured e.g. external to the vessel or somewhere within the vessel but external to the cargo space,
25 and the cargo hold temperature or other parameters may e.g. be measured at the inlet of the ventilation to the cargo space.

Figures

30 Fig. 1 Illustrates the basic setup of the ventilation control system of the present invention.

Fig. 2 Illustrates to two block control setup of the present invention.

Fig. 3 Illustrates a control including a optimum control and an alternative control.

Detailed description of the invention

5

A ventilation control system that uses one or more individually and continuously or intermittently measured and calculated physical parameter differences, e.g. one or more temperature differences, for the continuous or intermittently repeated calculation of the set point for the ventilation control, subsequently
10 controlling indirectly or directly the ventilation while establishing the optimal energy allocation between reefer container consumption and ventilation consumption while eliminating the need for prediction of the optimal cargo hold temperature.

15 The system consisting of at least two parameter sensors and a control arrangement establishes demand control ventilation and optimized energy allocation between reefer containers and ventilation. The energy allocation is not based on a prediction or lookup table but on a dynamic control algorithm that continuously adjusts the airflow and the energy allocation based on the
20 temperature difference between the cargo hold air temperature and ventilation inlet air temperature (or ambient temperature being anywhere external to the cargo space). By maintaining an individually calculated difference between the cargo hold temperature and the ventilation inlet air temperature, the need for a prediction of the optimal cargo hold temperature is eliminated. The system
25 maintains the airflow at the level where the cost of ventilating is balanced against the cost of cooling the containers in an environment with a relatively higher ambient temperature. At the same time the higher difference in temperature in the cargo hold and outside allows for the cooling air to have a higher efficiency as "refrigerant".

30

Figure 1 shows a preferred embodiment of the invention, the embodiment comprising at least two parameter sensors (1), a control arrangement with input interfaces (2), controller (3) with control algorithm (4), one or more optional I/O

interfaces (5), output interfaces (6) for indirect or direct control of ventilation devices (7) and one or more power supplies (8).

If the cargo hold temperature T_c is measured, e.g. at the inlet of the ventilation to the cargo space, and the ambient temperature T_{amb} is measured e.g. by a sensor positioned at the outside of the vessel, at the intake to the ventilation or somewhere else external to the cargo space, then the ventilation of the cargo space by the ventilation devices (7) is controlled in order to maintain the cargo hold temperature T_c to a set point temperature depending on the ambient temperature T_{amb} to a relation depending on a number of chosen parameters representative of the actual system composed of vessel, cargo space, reefer containers etc.

The set point cargo hold temperature thus is calculated by a relation:

15

$T_c \propto T_{amb} * f(\text{parameters representative of the system composed of vessel, cargo space, reefer containers etc., optionally in simplified form})$.

In one simple embodiment the relation is a linear relation, where this linear relation could be a simple difference between the container temperature T_c and the ambient temperature T_{amb} , where this difference is to be maintained at a constant.

Other parameters could be regulated in a similar manner and relation like e.g. humidity etc., air composition. The system in an more advanced version could use different relation for different parameters.

In another preferred embodiment, the invention may additionally utilize input or inputs from one or more parameter sensors measuring levels of one or more gasses, e.g. carbon dioxide, to establish limitation of the concentration of same gas or gasses present in the cargo hold by controlling the ventilation devices.

30

Claims

- 5 1) A ventilation control system for controlling the ventilation of cargo holds for reefer containers, said system having a number of parameter sensing devices, a number of parameters inputs, a controlling circuitry, a control function and a number of outputs, **characterized by** utilizing measurement of at least cargo hold parameters and ambient parameters and utilizing at least the difference of said parameters as a parameter to control the cargo hold ventilation amount.
- 10 2) A control system according to claim 1, wherein the cargo hold parameters include at least the cargo hold temperature T_c and the ambient parameters include at least the ambient temperature T_{amb} or a representation thereof and the parameter used to control the cargo hold ventilation amount includes at least the difference between the difference between the cargo hold temperature T_c and the ambient temperature T_{amb} .
- 15 3) A system according to claim 2, **characterized by** controlling the ventilation amount by activating or deactivating one or more ventilation devices.
- 20 4) A system according to claim 3, **characterized by** activating or deactivating inlet ventilators and exhaust ventilation devices in predetermined sequence.
- 25 5) A system according to one of claims 2) or 3), **characterized by** controlling the ventilation devices indirectly.
- 30 6) A system according to one of claims 2) or 3) or 4), **characterized by** having a programmable user interface.

- 7) A system according to one of claims 2) or 3) or 4) or 5), **characterized by** having a an override function.
- 5 8) A system according to claim 6), **characterized by** utilizing measurement of concentration levels of one or more gasses and limit the concentration of same gas or gasses present in the cargo hold by controlling the ventilation devices overriding temperature signals.
- 10 9) A system according to claim 6) or 7), **characterized by** having one or more inputs or outputs for remote monitoring and control.

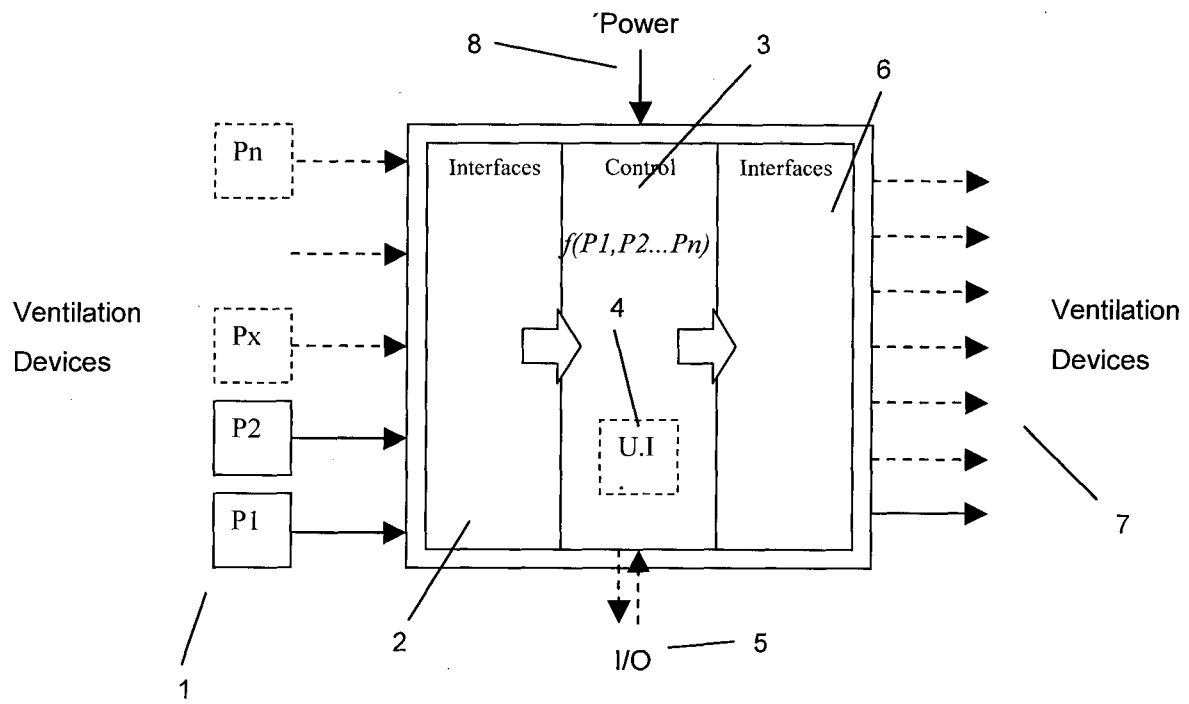

Fig. 1

INTERNATIONAL SEARCH REPORT

International application No PCT/DK2013/000034
--

A. CLASSIFICATION OF SUBJECT MATTER INV. B63J2/08 B60H1/00 F24F11/00 ADD.				
According to International Patent Classification (IPC) or to both national classification and IPC				
B. FIELDS SEARCHED				
Minimum documentation searched (classification system followed by classification symbols) B63J B60H F24F B65D F25D				
Documentation searched other than minimum documentation to the extent that such documents are included in the fields searched				
Electronic data base consulted during the international search (name of data base and, where practicable, search terms used) EPO-Internal, WPI Data				
C. DOCUMENTS CONSIDERED TO BE RELEVANT				
Category*	Citation of document, with indication, where appropriate, of the relevant passages	Relevant to claim No.		
X	JP H08 128685 A (SHIMIZU HAJIME; KANEKO YOSHIAKI) 21 May 1996 (1996-05-21) claims 1-4 abstract figures 1-4	1-9		
X	----- DE 198 31 787 A1 (DENSO CORP [JP]) 21 January 1999 (1999-01-21) column 21, line 23 - column 22, line 54 figures 37-39	1-9		
X	----- EP 1 780 077 A1 (DIRNHOFER RAINER [DE]) 2 May 2007 (2007-05-02) paragraphs [0017] - [0019], [0044] - [0049] figure 1	1-9		
----- -/--				
<table style="width: 100%; border: none;"> <tr> <td style="width: 50%; border: none;"><input checked="" type="checkbox"/> Further documents are listed in the continuation of Box C.</td> <td style="width: 50%; border: none;"><input checked="" type="checkbox"/> See patent family annex.</td> </tr> </table>			<input checked="" type="checkbox"/> Further documents are listed in the continuation of Box C.	<input checked="" type="checkbox"/> See patent family annex.
<input checked="" type="checkbox"/> Further documents are listed in the continuation of Box C.	<input checked="" type="checkbox"/> See patent family annex.			
* Special categories of cited documents :				
"A" document defining the general state of the art which is not considered to be of particular relevance "E" earlier application or patent but published on or after the international filing date "L" document which may throw doubts on priority claim(s) or which is cited to establish the publication date of another citation or other special reason (as specified) "O" document referring to an oral disclosure, use, exhibition or other means "P" document published prior to the international filing date but later than the priority date claimed	"T" later document published after the international filing date or priority date and not in conflict with the application but cited to understand the principle or theory underlying the invention "X" document of particular relevance; the claimed invention cannot be considered novel or cannot be considered to involve an inventive step when the document is taken alone "Y" document of particular relevance; the claimed invention cannot be considered to involve an inventive step when the document is combined with one or more other such documents, such combination being obvious to a person skilled in the art "&" document member of the same patent family			
Date of the actual completion of the international search	Date of mailing of the international search report			
8 August 2013	20/08/2013			
Name and mailing address of the ISA/ European Patent Office, P.B. 5818 Patentlaan 2 NL - 2280 HV Rijswijk Tel. (+31-70) 340-2040, Fax: (+31-70) 340-3016	Authorized officer Blazquez Lainez, R			

INTERNATIONAL SEARCH REPORT

International application No
PCT/DK2013/000034

C(Continuation). DOCUMENTS CONSIDERED TO BE RELEVANT

Category*	Citation of document, with indication, where appropriate, of the relevant passages	Relevant to claim No.
X	US 5 275 011 A (HANSON JAY L [US] ET AL) 4 January 1994 (1994-01-04) column 1, line 35 - column 2, line 11 column 3, lines 1-18,39-55 column 7, lines 7-28 column 10, lines 3-32 figure 1	1-9
X	----- WO 2011/050157 A2 (CARRIER CORP [US]; ZEIDNER LAWRENCE E [US]) 28 April 2011 (2011-04-28) paragraphs [0006], [0007], [0009], [0010], [0012], [0035], [0038], [0039], [0056], [0066] claims 1,11 figures 1-8 -----	1-9

INTERNATIONAL SEARCH REPORT

Information on patent family members

International application No PCT/DK2013/000034

Patent document cited in search report	Publication date	Patent family member(s)	Publication date
JP H08128685	A	21-05-1996	NONE
DE 19831787	A1	21-01-1999	NONE
EP 1780077	A1	02-05-2007	DE 102005051744 A1 03-05-2007 EP 1780077 A1 02-05-2007
US 5275011	A	04-01-1994	DE 69316969 D1 19-03-1998 DE 69316969 T2 01-10-1998 DK 0602936 T3 23-09-1998 EP 0602936 A2 22-06-1994 US 5275011 A 04-01-1994
WO 2011050157	A2	28-04-2011	CN 102548627 A 04-07-2012 EP 2491325 A2 29-08-2012 US 2012198866 A1 09-08-2012 WO 2011050157 A2 28-04-2011