

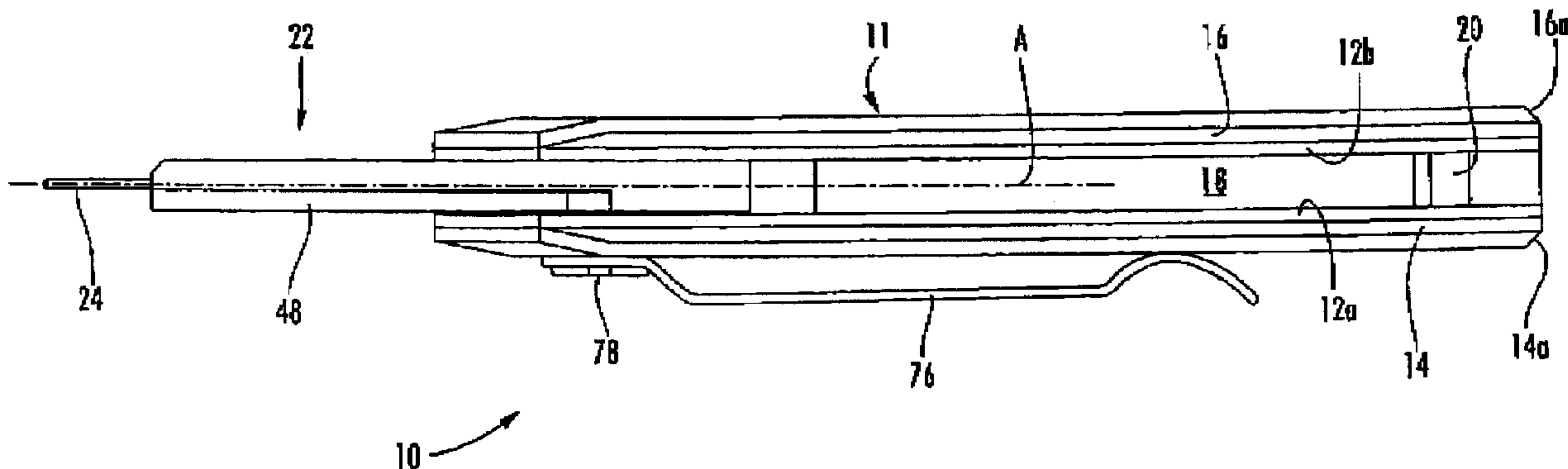

(22) Date de dépôt/Filing Date: 2009/04/03  
 (41) Mise à la disp. pub./Open to Public Insp.: 2009/11/02  
 (45) Date de délivrance/Issue Date: 2012/07/31  
 (30) Priorité/Priority: 2008/05/02 (US12/114,234)

(51) Cl.Int./Int.Cl. *B26B 1/08* (2006.01),  
*B26B 1/10* (2006.01), *B26B 5/00* (2006.01)  
 (72) Inventeur/Inventor:  
HUANG, YUAN DE, CN  
 (73) Propriétaire/Owner:  
OLYMPIA TOOLS INTERNATIONAL, INC., US  
 (74) Agent: ADAMS PATENT & TRADEMARK AGENCY

(54) Titre : COUTEAU UNIVERSEL RETRACTABLE  
 (54) Title: RETRACTABLE UTILITY KNIFE



(57) **Abrégé/Abstract:**

A retractable knife includes an elongate handle and a blade holder slidably mounted within the handle for sliding movements between a retracted position and an extended position. The blade holder is configured for receiving. A manually operable blade lock is formed on the holder and including a release member rotatably mounted on the blade holder. The release member having a first portion projecting beyond the handle and positioned to be actuated by a finger of a user while holding the handle. A second portion is movable with the first portion between a locking position in which the second portion is received with a notch of a blade and a releasing position in which the second portion is removed from the blade notch to a position outside the notch of the blade. A spring normally rotates the release member to move the second portion to the locking position. Actuation of the release member by the finger of the user to overcome the spring moves the second portion to the releasing position and releases the blade.



**ABSTRACT**

A retractable knife includes an elongate handle and a blade holder slidably mounted within the handle for sliding movements between a retracted position and an extended position. The blade holder is configured for receiving a blade. A manually operable blade lock is formed on the holder and including a release member rotatably mounted on the blade holder. The release member having a first portion projecting beyond the handle and positioned to be actuated by a finger of a user while holding the handle. A second portion is movable with the first portion between a locking position in which the second portion is received within a notch of a blade and a releasing position in which the second portion is removed from the blade notch to a position outside the notch of the blade. A spring normally rotates the release member to move the second portion to the locking position. Actuation of the release member by the finger of the user to overcome the spring moves the second portion to the releasing position and releases the blade.

**RETRACTABLE UTILITY KNIFE**  
**BACKGROUND OF THE INVENTION**

**Field of the Invention:**

The present invention generally related to a hand tools, and more specifically to a retractable utility knife with a quick release blade mechanism.

**Description of the Prior Art:**

Conventional utility knives have various types of structures including fixed, foldable and retractable. They are generally used to cut paper, fabric, and leather. The Chinese Patent Application No. 93208241.6 (Publication Date: June 22, 1994) disclosed "a retractable rope-cut utility knife", in which a blade stored in a handle is extended out step by step by moving a slider. However, it is not convenient to replace the blade. The Chinese Patent Application No. 03223149.0 (Publication Date: December 24, 2003) disclosed "a combined utility knife". It is convenient to replace a blade by arranging the blade in a groove of the handle assembly and using a top cover in connection with a lock member. However, the following problems exist. The structure is complex; when replacing a blade, a user needs to release the lock member first and then rotate the top cover, which is complicated and inconvenient. The Chinese Patent Application No. 20042010202117.2 (Publication Date: February 8, 2006) disclosed "a utility knife" in which a blade is arranged in a mounting groove of a handle assembly and a fixing hole is provided in the handle assembly. A bolt anchored in the fixing hole secures the blade.

This utility knife is also disadvantageous because extra tools are used when the blade is replaced.

#### SUMMARY OF THE INVENTION

Accordingly, it is an object of the invention to provide a retractable utility knife which does not include the disadvantages inherent in prior art utility knives.

It is another object of the invention to provide a retractable utility knife that is simple in construction and economical to manufacture.

It is still another object of the invention to provide a retractable utility knife as in the previous objects which permits one hand operation for releasing a blade from a retractable utility knife.

It is yet another object of the invention to provide a retractable utility knife of the type under discussion that is easy and convenient to use.

It is a further object of the invention to provide a retractable utility knife as suggested in the previous objects that is ergonomically configured to allow a blade to be released with the thumb of a user while the blade is being held in the same hand of the user.

It is still a further object to provide a utility knife as in the previous objects that has a slim profile and easy to store and transport.

In order to achieve one or more of the above objects, as well as others which will become apparent hereafter, a retractable utility knife in accordance with one aspect of the present invention comprises an elongate handle defining a handle axis; a blade holder slidably mounted within said handle for sliding movement along said handle between a retracted position and an extended position and having an upper edge, receiving means within said blade holder for receiving at least a portion of a blade provided with one edge formed with a cutting edge and opposing edge formed with a notch; and a manually operable blade lock formed on said blade holder and comprising a release member rotatably mounted on said blade holder, said release member having a first portion on said blade holder and positioned to be actuated by a finger of the same hand of a user holding said handle, and a second portion mounted on said first portion for movement with said first portion between a locking position in which said second portion is received within a notch of a blade and a releasing position in which said second portion is removed from the blade notch to a position beyond the notch of the blade, said release member having a release member axis substantially

normal to said handle axis and rotatably mounted on said blade holder for rotation about said release member axis, and biasing means for normally moving said release member to move said second portion to said locking position, whereby actuation of said release member by the finger of the user to overcome said biasing means moves said second portion to said releasing position for releasing the blade so that it can be withdrawn from said receiving means.

In operation, actuation of the release member by the finger of the user to overcome the biasing force moves the second portion to the releasing position and the blade can be quickly and conveniently removed from the blade holder.

### BRIEF DESCRIPTION OF THE DRAWINGS

Other objects and features of the present invention may become clear from the following description taken in conjunction with the preferred embodiments thereof with reference to the accompanying drawings, in which:

Fig. 1 is a bottom plan view of a retractable utility knife in accordance with the invention, shown with the blade and blade carriage in an extended position;

Fig. 2 is a right side elevational view of the utility knife shown in Fig. 1;

Fig. 3 is a top plan view of the retractable utility knife shown in Figs. 1 and 2;

Fig. 4 is a rear side elevational view of the utility knife shown in Figs. 1-3;

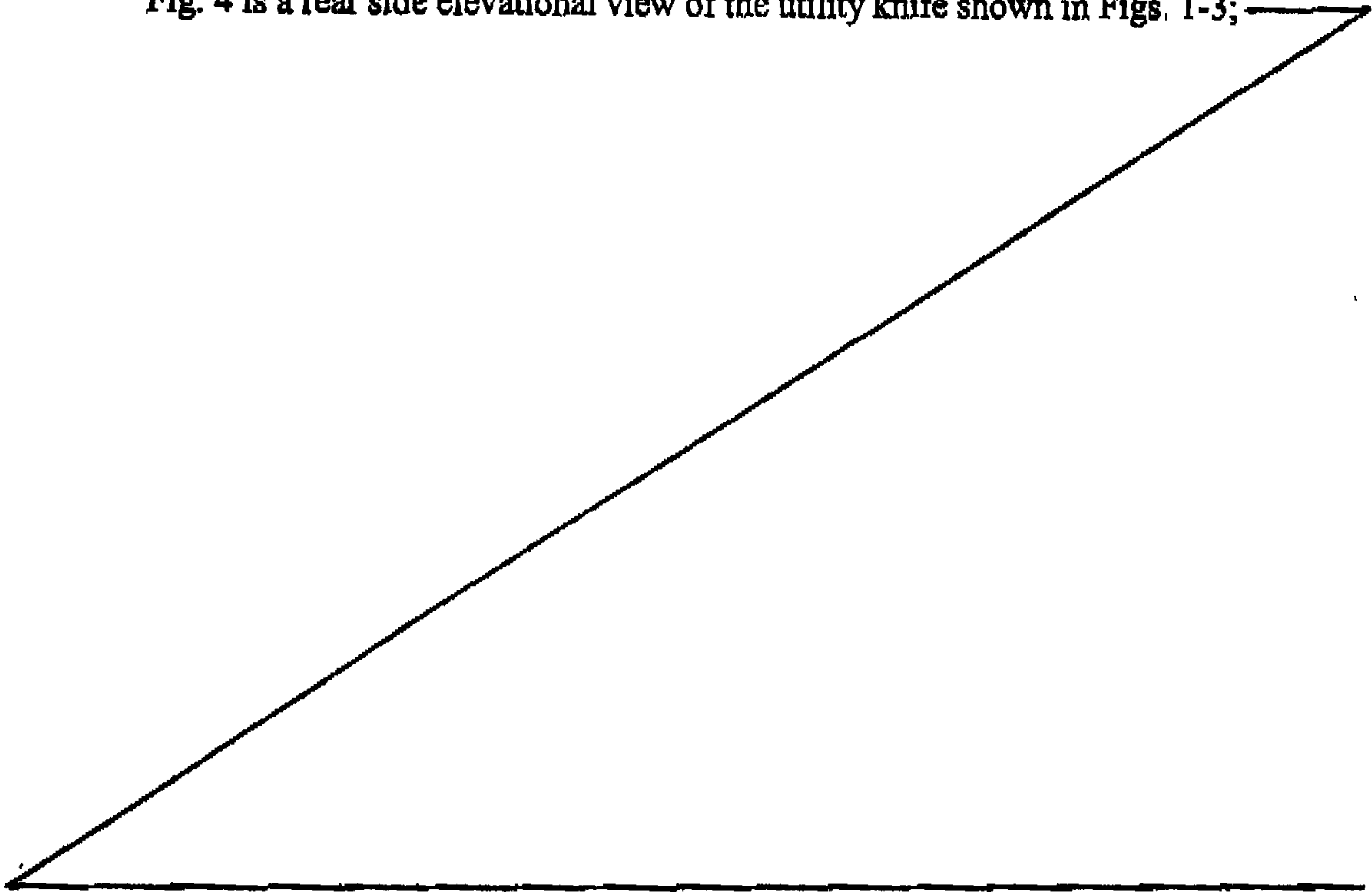

Fig. 5 is an exploded perspective view of the handle forming part of the retractable utility knife shown in Figs. 1-4;

Fig. 6 is a perspective view of a utility blade of the type that can be used with the retractable utility knife;

Fig. 7 is a right side elevational view of the carriage slidably mounted within the handle of the retractable utility knife, showing the details of a release button when it is in its upwardly extended, carriage-locking position;

Fig. 8 is similar to Fig. 7, but showing the reverse side of the carriage and further showing a cover plate removed from the forward or front end of the carriage to illustrate the details of the locking and releasing disk and the manner in which it is biased and used to selectively lock or release a blade received within the carriage or blade holder;

Fig. 9 is a side elevational view of the cover plate removed from the carriage and normally covering the blade locking and releasing mechanism shown in Fig. 8; and

Fig. 10 is a perspective view of a flat strip receivable within a transverse through hole or slot in the release button shown in Figs. 7 and 8 for selectively engaging indents within the handle for selectively locking or releasing the carriage from longitudinal sliding movements relative to the handle.

#### DESCRIPTION OF PREFERRED EMBODIMENT

Referring now specifically to the Figures, in which identical or similar parts are designated by the same reference numerals throughout, and first referring to Figs. 1-5, a retractable utility knife in accordance with the present invention is generally designated by the reference numeral 10.

The retractable utility knife 10 includes a handle 11, an exploded view of which is shown in Fig. 5. The handle 11 is generally elongate, as shown, and generally defines an axis A along its length direction. The handle 11 is preferably ergonomically configured to provide a comfortable grip by a user using the utility knife.

The handle 11 is formed of an inner frame 12 which includes spaced right and left plates or rails 12a, 12b separated a suitable or desired distance by means of a bridging strip 12c, best shown in Fig. 3. In the presently preferred embodiment, the plates or rails 12a, 12b are spaced approximately 0.25" apart. The inner frame 12 is, in accordance with the present invention, formed of stainless steel, although other rigid materials can be used. Since the bridging strip 12c is formed at the remote end of the handle 11, suitable spacers, to be described, are provided for maintaining the right and left plates or rails 12a, 12b at a fixed spacing from each other. Preferably, the inner facing surfaces of the plates or rails 12a, 12b are polished to provide smooth surfaces that minimize sliding friction.

A right cover 14 is mounted on the right plate or rail 12a, the right cover being provided with a beveled edge 14a, as shown, and exposed right surface 14b. Similarly, a left cover 16 is provided with a bevel 16a and exhibits a left surface 16b when mounted on the left plate or rail 12b. The right and/or left covers 14, 16 are preferably provided with suitable ornamentation 16c, as suggested in Fig. 5.

A gap or space 18 resulting between the right and left rails or plates 12a, 12b is maintained at a desired spacing by means of spacers 20 of the type shown in Figs. 3 and 5. Any suitable number of spacers may be provided to maintain the inner frame essentially fixed or rigid and the gap or space 18 uniform. In the presently preferred

embodiment the spacing between the inner, facing surfaces of the plates or rails 12a, 12b is approximately 3/16".

Mounted for sliding movements within the inner frame 12, or between the right and left plates or rails 12a, 12b is a blade holder or carriage 22 that is received within the gap or space 18 of the inner frame 12 for sliding movements relative to the frame 12 and the handle 11 essentially along the length direction or axis A of the handle 11. The carriage is preferably formed of stainless steel, although other comparable materials can also be used. The lateral right and left surfaces of the carriage facing the inner surfaces of the rails or plates 12a, 12b are preferably polished to provide smooth surfaces to minimize sliding friction with the smooth, polished, facing surfaces of the rails or plates. The thickness or transverse dimension of the carriage 22 is selected to allow the carriage to be received within the gap or space 18 to allow free longitudinal sliding movements without any significant lateral play. Preferably, a suitable lubricant, such as oil or silicone-based lubricants, are applied between the frame 12 and the carriage 22 to provide smooth movements involving little friction.

The carriage or blade holder 22 is provided with a receiving cavity for receiving at least a portion of a blade of the type generally shown in Fig. 6. The blade 24 is a conventional trapezoidal-shaped utility knife blade of the type commonly used in numerous utility knives. The blade is typically formed along its lower or larger base with a cutting edge 24a, while the opposing upper or shorter base is formed with at least one notch 24c. Typically, such blades are provided with two spaced notches 24c as shown so that with most utility knives in which these blades are used they can be reversed and utilized irrespective of which pointed edge extends beyond the utility knife during use.

Referring specifically to Figs. 7-10, the carriage or blade holder 22 is shown formed of a solid block portion 22a, at the rear or proximate end of the carriage 22, while the forward or remote end of the carriage 22 is provided with the blade receiving cavity 22b, in which material has been removed, as shown, to provide various cavities or recesses to be described. The forward or remote edge 22c is inclined to expose a triangular section of the blade 24 when it is exposed outside of the carriage during use.

Referring specifically to Fig. 8, the front or remote portion 22b of the carriage 22 is formed with a number of cavities having different depths. Thus, along the upper and lower edges there are provided mounting strips on which a cover plate 48 can be attached to enclose the various cavities or recesses shown in Fig. 8. The cover plate 48 is shown in Fig. 9.

The upper mounting strip 25 forms a step or upper guide edge 28 while the lower mounting strip 25 forms a lower step or upper guide edge 30, the guide edges being parallel to each other and together define a guide surface 26 against which one surface of the blade 24 can slide. Additional bosses, such as boss 26a, can be provided whose outer surfaces are co-extensive with the guide surface 26 to provide support and facilitate sliding movements of the blade relative to the guide surface 26.

Referring to Fig. 7, a circular recess 23 is provided in the face or outer surface of the carriage 22, as shown, the radial distance of the center of the circular recess being less than its radius from the upper edge of the carriage, as shown, so that an upper arc of the circular recess 23 forms an opening through the upper edge of the carriage. A circular release disk 32 is rotatably mounted on a suitable pivot pin 38 (Fig. 8) so that at least a portion of the release disk extends or projects above the upper edge of the carriage as

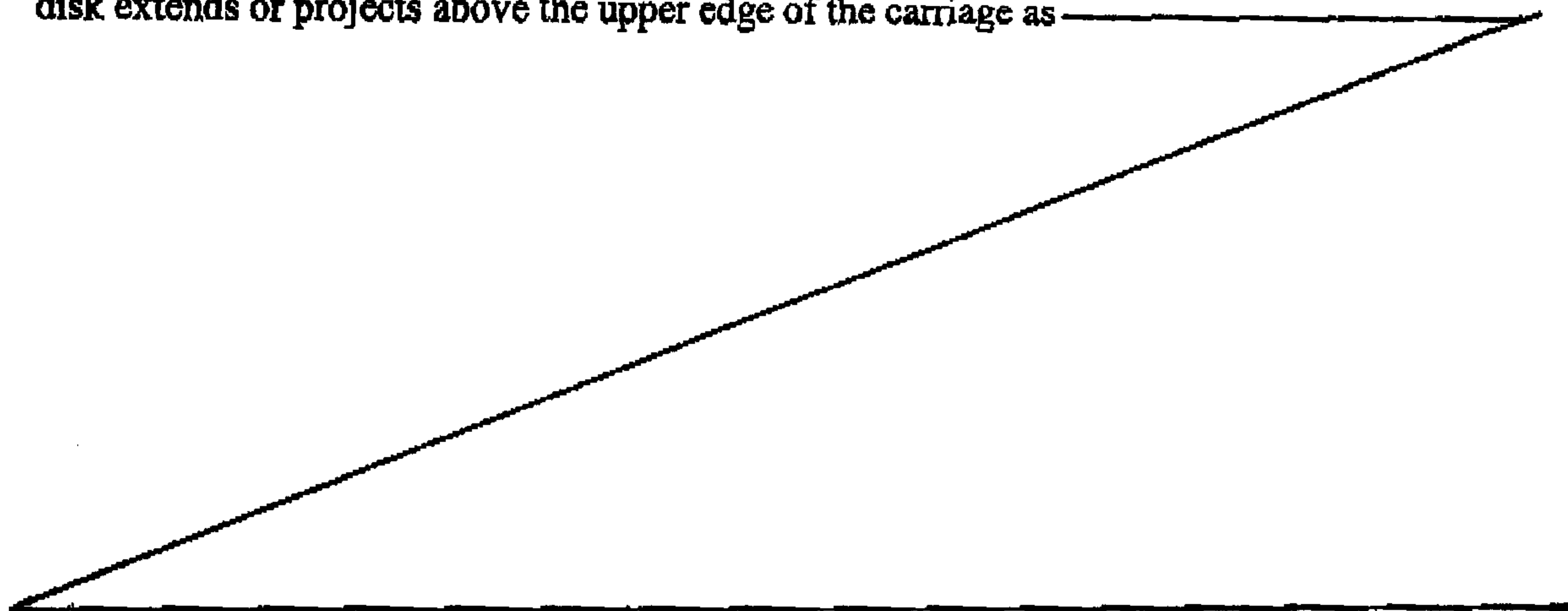

shown. Preferably, the portion of the release disk 32 that projects above the upper edge of the carriage is provided with a ribbed or knurled edge, as shown, to facilitate gripping with a finger of a user.

Referring to Fig. 8, a cutout or opening 36a, shown as an arcuate cavity, is provided behind the release disk 32 and, similarly, a second cutout 36b is provided somewhat diametrically opposite to the cutout 36a. A biasing finger 38, attached to or forming a part of the release disk 32 projects through the cutout 36b. However, the biasing finger 38 does not project beyond the guide surface 26 so as not to interfere with any blade supported on the guide surface 26. A suitable biasing member is provided for engaging the biasing finger 38. The biasing member in Fig. 8 is shown to be a leaf spring 40 having the fixed end 40a received within a recess 42 and a moveable or free end 40b that engages the biasing finger 38 and urges the biasing finger 38 upwardly, as shown in Fig. 8, to rotate the release disk 32 in a generally clockwise direction.

A stop finger 44 projects transversely from the release disk 32 into the arcuate cutout 36a. However, the stop finger 44 projects beyond the guide surface 26 by a distance that is substantially equal to the thickness of the blade 24. The stop pin or finger 44 is configured so that in a locking position of the blade, as shown in Fig. 8, the stop finger or pin 44 is received within one of the notches 24c which fixes the position of the blade and prevents it from moving longitudinally along the steps or guide edges 28, 30 relative to the carriage 22. It will be evident that when a user places his or her finger, typically the thumb, on the release disk 32 and pulls the projecting top edge of the disk and urges the disk towards the proximate or towards the rear of the handle 11, the release disk rotates in a counterclockwise direction, as viewed in Fig. 8, against the biasing

forces of the spring 40. The spring 40 is selected to bias the release disk 32 to its normal locking position although readily rotatable to an unlocking position, when the stop pin or finger 44 is elevated or lifted out of one of the notches 24c of the blade without too much force or resistance. Like the biasing finger 38, the spring 40 is placed within a cavity below the plane of the guide surface 26 so that the movements of the spring and the biasing finger 38 do not contact and do not interfere with the members of the blade.

When assembled, the cover plate 48 can be positioned over the recessed portions 22b of the carriage, at which time the tabs 46 are received within the recesses 48a of the cover plate and suitable fasteners can be used to secure the cover plate to the rest of the carriage. The thickness of the steps 28, 30 substantially correspond to the thickness of the blade so that when a cover plate 48 is secured onto the mounting strips 25 a receiving space is maintained for allowing a blade to be slidably inserted or removed from the carriage or blade holder 22 when the release disk 32 is rotated in a counterclockwise direction to lift the stop finger or pin 44 to avoid interference with the free movements of the blade.

Referring to Fig. 7 and 8, the rear or proximate end of the carriage is provided with a T-shaped slot that includes a lower narrow slot 50 and a wide upper slot 52, both slots being substantially aligned along a direction that is generally normal or perpendicular to the lengthwise direction or axis A of the handle 11. A release button 54, which may be formed of a slip resistant material, such as rubber or rubber-like material, is formed with a downwardly depending post or stem 56. The axial length of the release button 54 is somewhat less than the width of the wide slot 52 while the axial or lengthwise dimension of the narrow slot 50 is somewhat greater than the dimension of the

stem, as shown, so that the stem 56 can be received within the narrow slot 50 with some clearance and, likewise, the release button 54 can be received with some clearance within the wide slot 52. In this way, the release button 54 can move downwardly or upwardly within the slots of the resulting T-shaped slot. A suitable spring 60, such as helical spring, is arranged between the lower most surface of the narrow slot 50 and captured between that surface and the stem 56 so that the helical spring 60 normally biases or urges the release button 54 to move in an upward direction, although a downward pressure on the release button 54 by a user can move the release button downwardly into the wide slot 52 against the action of the spring.

A transverse slot 58 is formed within the post or stem 56 through which a transverse bar or pin 62 may be inserted, as shown in Fig. 7. Referring to Fig. 5, the right and left rails 12a, 12b are provided with upper tracks 64 that extend along the longitudinal direction along the axis A of the handle. Similarly, corresponding lower tracks 66 are provided in each of the rails or plates 12a, 12b that are parallel to the upper tracks 64. At least two indents are provided in the upper tracks 64, extending in an upper direction away from the lower tracks 66 as shown in Fig. 5. In the embodiment shown, a single front indent 68 is provided at the front or remote end of the upper tracks 64 and two spaced rear indents 70 are provided at the rear or proximate ends of the upper tracks. Referring to Fig. 10, a transverse bar or pin 62, when placed within the slot 58, is dimensioned to project to each side of the stem or post 56 to be receivable within the upper tracks 64 for sliding movements within the upper tracks. The location of the slot 58 and, therefore, the transverse bar or pin 62 is selected so that when the helical spring 60 urges the stem 56 upwardly this biases the bar or pin 62 upwardly and, when juxtaposed

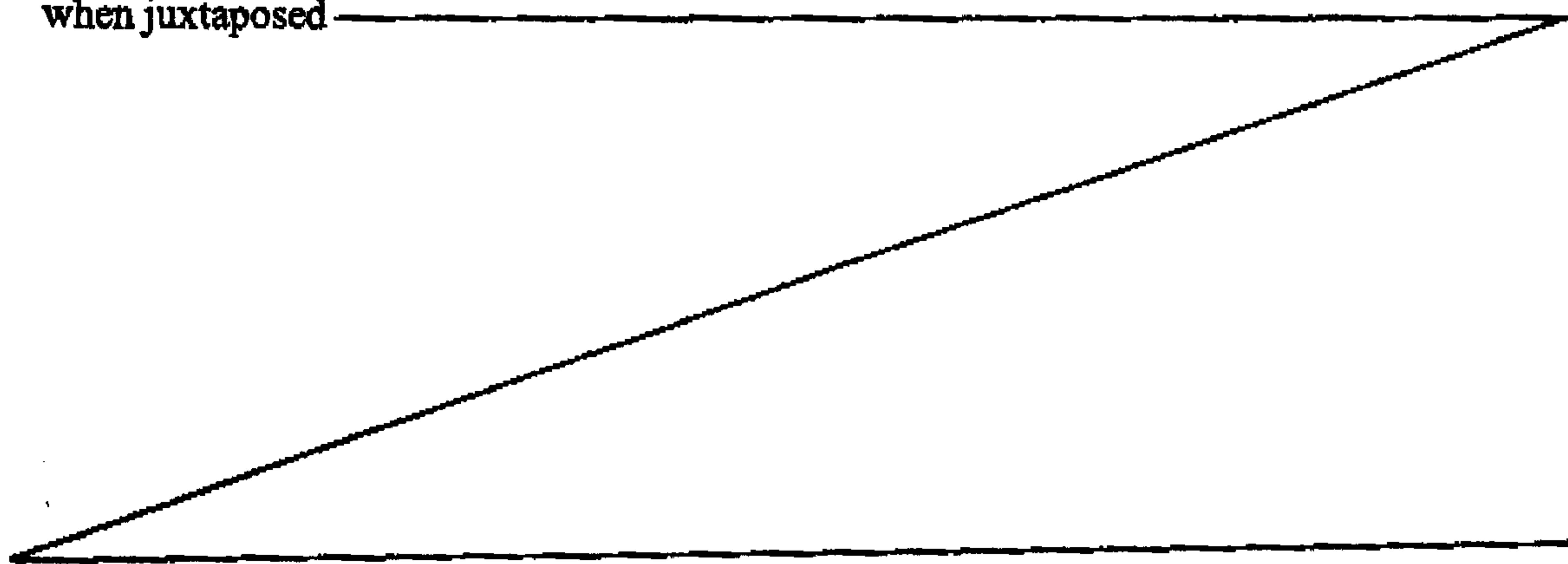

against one of the indents 68, 70, the bar or pin 62 will be urged into an indent below which it is placed. It should be evident that once the bar or pin 62 is received within one of the indents 68, 70 this locks the carriage 22 from longitudinal sliding movements along the axis A of the carriage. However, when the release button 54 is pressed downwardly, against the action of the spring 60, the bar or pin 62 is urged out of a recess in which it has been positioned, at which time a longitudinal or axial force on the release button forwardly or rearwardly causes the carriage or blade holder 22 to slide forwardly or rearwardly, depending on the direction of the force applied by the user's thumb. This allows a user to selectively lock the carriage, and any blade secured therein by the release disk 32, to slide forwardly to an extended position shown in Figs. 1-4 or rearwardly, at which time the carriage or blade holder is locked or secured in its retracted position.

To facilitate sliding and to stabilize the movements of the carriage between extended and retracted positions, there are provided upper holes 72 and lower holes 74 in the carriage through which suitable stabilizing pins 75 (one shown in Fig. 9) may extend, pins dimensioned to be received within the tracks 64, 66 with some but little clearance. Two upper holes 72 and two lower holes 74 are shown in Fig. 8, these holes being arranged along substantially parallel lines spaced to correspond to the spacing between the speed tracks 64, 66. This ensures that the carriage moves longitudinally along the handle 11 with a smooth stable motion and without any rotational movement components.

Suitable fasteners, such as screws or rivets may be used to secure the cover plate 48 to the carriage and the covers 14, 16 to the inner frame 12. The specific fasteners used are not critical for purposes of the invention.

In the embodiment illustrated, there is also provided an optional spring clip 76 secured to the right cover 14 by means of rivets or screw 78.

By making the release button 54 from an elastomeric or other non-slip resistant material this makes it easier for a user to push the release button downwardly and rearwardly or downwardly and forwardly without slippage.

With the retractable knife disclosed the utility knife has a carriage or blade holder 22 that, with the blade fixed thereon, can be fully retracted within the handle 11 or extended as shown in Figs. 1-4. It will be appreciated that once the carriage or blade holder is fully retracted within the handle the overall length of the utility knife becomes significantly shorter than the extended length. The design makes it possible to make the utility knife relatively slim and short and portable both within a tool box or tool bag, on the person, clipped to a belt, etc. Movements of the carriage from a retracted to extended positions, as well as quick release of the blade by rotation of the release disk are all one hand operations.

While the invention has been shown and described in connection with a preferred form of an embodiment, it will be understood that modifications may be made without the departure from the scope of the invention as defined in the appended claims.

## CLAIMS

1. Retractable knife comprising an elongate handle defining a handle axis; a release button mounted for movements along said handle axis; a blade holder slidably mounted within said handle responsive to actuation of said release button for sliding movements along said handle between a retracted position and an extended position in which at least a portion of said blade holder extends beyond said handle and having an upper edge, receiving means within said blade holder for receiving at least a portion of a blade provided with one edge formed with a cutting edge and opposing edge formed with a notch; and a manually operable blade lock formed on said portion of said blade holder and comprising a release member rotatably mounted on said blade holder, said release member having a first portion on said blade holder and mounted to be actuated by movement of a finger of the same hand of a user holding said handle along a direction substantially parallel to said handle axis, and a second portion mounted on said first portion for movements with said first portion between a locking position in which said second portion is received within said notch of said blade and a releasing position in which said second portion is removed from the blade notch to a position beyond the notch of the blade, said release member being substantially in the form of a disc having an axis of rotation substantially normal to said handle axis and rotatably mounted on said blade holder for rotation about said release member axis of rotation, said first portion at least partially projecting above said upper edge of said blade holder to always be exposed for engagement by the user in both said blade locking and blade releasing positions when said release member is actuated while said blade holder is extended along said handle axis beyond said handle at a position spaced from said release button in the direction of the blade to be removed, and biasing means for normally moving said release member to move said second portion to said locking position, whereby actuation of said release member by the finger of the user to overcome said biasing means moves said second portion to said releasing position for releasing the blade so that it can be withdrawn from said receiving means.

2. Retractable knife as defined in claim 1, wherein said release member comprises substantially a circular disc.
3. Retractable knife as defined in claim 2, wherein said first portion comprises an arc of said disc that projects beyond said upper edge of said blade holder.
4. Retractable knife as defined in claim 3, wherein said first portion is provided with gripping means for enhancing friction when gripped by a finger of a user seeking to rotate said disc against the action of said biasing means.
5. Retractable knife as defined in claim 4, wherein said gripping means comprises a non-smooth edge along said arc.
6. Retractable knife as defined in any one of claims 1 to 5, wherein said second portion is fixedly mounted on said first portion.
7. Retractable knife as defined in any one of claims 1 to 6, wherein said blade holder is received within a longitudinal space or gap within said handle with a sliding fit, facing surfaces of said blade holder and handle being polished to minimize sliding friction.
8. Retractable knife as defined in claim 7, further comprising a lubricant at said facing surfaces to reduce sliding friction.
9. Retractable knife as defined in any one of claims 1 to 8, wherein said release button comprises a blade holder lock on said blade holder and has a gripping portion extending beyond said handle to be engageable by said finger and for selectively locking said blade holder against movements between said extended and retracted positions and releasing said blade holder for movement from one of said positions to the other.
10. Retractable knife comprising an elongate handle; defining a handle axis; a release button mounted for movements along said handle axis; a blade holder slidingly mounted

within said handle responsive to actuation of said release button for sliding movements relative to said handle between a retracted position and an extended position in which at least a portion of said blade holder extends beyond said handle and having an upper edge, receiving means within said blade holder for receiving at least a portion of a blade provided with one edge formed with a cutting edge and opposing edge formed with a notch; and a manually operable blade lock formed on said portion of said blade holder and comprising a release member rotatably mounted on said blade holder, said release member having a first portion on said blade holder and mounted to be actuated by movement of a finger of the same hand of a user holding said handle along a direction substantially parallel to said handle axis, and a second portion mounted on said first portion for movements with said first portion between a locking position in which said second portion is received within said notch of said blade and a releasing position in which said second portion is removed from the blade notch to a position beyond the notch of the blade, said release member being substantially in the form of a disc having an axis of rotation substantially normal to said handle axis and rotatably mounted on said blade holder for rotation about said release member axis of rotation, said first portion at least partially projecting above said upper edge of said blade holder to always be exposed for engagement by the user in both said blade locking and blade releasing positions when said release member is actuated while said blade holder is extended along said handle axis beyond said handle at a position spaced from said release button in the direction of the blade to be removed, and biasing means for normally moving said release member to move said second portion to said locking position, said blade holder being received within a longitudinal space or gap within said handle with a sliding fit, facing surfaces of said blade holder and handle being polished to minimize sliding friction, whereby actuation of said release member by the finger of the user to overcome said biasing means moves said second portion to said releasing position for releasing the blade so that it can be withdrawn from said receiving means.

11. Retractable knife as defined in claim 10, further comprising a lubricant at said facing surfaces to reduce sliding friction.

12. Retractable knife comprising an elongate handle defining a handle axis; a release button mounted for movements along said handle axis; a blade holder slidably mounted within said handle responsive to actuation of said release button for sliding movements relative to said handle between a retracted position and an extended position in which at least a portion of said blade holder extends beyond said handle and having an upper edge, receiving means within said blade holder for receiving at least a portion of a blade provided with one edge formed with a cutting edge and opposing edge formed with a notch; and a manually operable blade lock formed on said portion of said blade holder and comprising a release member on said blade holder, said release member having a first portion rotatably mounted on said blade holder and mounted to be actuated by movement of a finger of the same hand of a user holding said handle along a direction substantially parallel to said handle axis, and a second portion mounted on said first portion for movements with said first portion between a locking position in which said second portion is received within said notch of said blade and a releasing position in which said second portion is removed from the blade notch to a position beyond the notch of the blade, said release member being substantially in the form of a disc having an axis of rotation substantially normal to said handle axis and rotatably mounted on said blade holder for rotation about said release member axis of rotation, said first portion at least partially projecting above said upper edge of said blade holder to always be exposed for engagement by the user in both said blade locking and blade releasing positions when said release member is actuated while said blade holder is extended along said handle axis beyond said handle at a position spaced from said release button in the direction of the blade to be removed, and biasing means for normally moving said release member to move said second portion to said locking position, said handle having a thickness or width in a direction normal to said axis that is approximately 0.5", whereby actuation of said release member by the finger of the user to overcome said biasing means moves said second portion to said releasing position for releasing the blade so that it can be withdrawn from said receiving means.

13. Retractable knife as defined in claim 12, wherein said blade holder has a thickness or width in said normal direction that is approximately 50% of said width of said handle.

14. Retractable knife as defined in claim 13, wherein said thickness or width of said blade holder is approximately 3/16".
15. Retractable knife as defined in claim 12, wherein said knife defines an axis and has a length along said axis of approximately 4.5" in said retracted position of the blade.
16. Retractable knife as defined in claim 12, wherein said knife defines an axis and has a length along said handle axis of approximately 6.25" in said extended position of the blade.
17. Retractable knife as defined in claim 12, wherein said knife defines an axis and the length of the knife along said axis in said retracted position of the blade is within the range of 35-45% of the length of the knife in said extended position of the blade.
18. Retractable knife comprising an elongate handle having an upper edge generally proximate to the thumb of a user when held during normal use; said handle defining a handle axis; a release button mounted for movements along said handle axis; a blade holder slidably mounted within said handle responsive to actuation of said release button for sliding movements relative to said handle between a retracted position and an extended position in which at least a portion of said blade holder extends beyond said handle and having an upper edge, receiving means within said blade holder for receiving at least a portion of a blade provided with one edge formed with a cutting edge and opposing edge formed with a notch; a manually operable blade lock formed on said portion of said blade holder and comprising a rotatably mounted release member mounted on said blade holder, said release member having a first portion on said blade holder and mounted to be actuated by movement of a finger of the same hand of a user holding said handle along a direction substantially parallel to said handle axis, and a second portion mounted on said first portion for movements with said first portion between a locking position in which said second portion is received within said notch of said blade and a releasing position in which said second portion is removed from the

blade notch to a position beyond the notch of the blade, said release member is substantially in the form of a disc having an axis substantially normal to said handle axis and rotatably mounted on said blade holder for rotation about said release member axis of rotation, said first portion at least partially projecting above said upper edge of said blade holder to always be exposed for engagement by the user in both said blade locking and blade releasing positions when said release member is actuated while said blade holder is extended along said handle axis beyond said handle at a position spaced from said release button in the direction of the blade, and biasing means for normally moving said release member to move said second portion to said locking position, said handle being formed with a gap or slot along at least a portion of said upper edge; and a release button extending above said upper edge and coupled to said blade holder, whereby actuation of said release button by the thumb of the user to slidably move said blade holder while holding said handle slidably moves said blade holder between said retracted and extended positions.

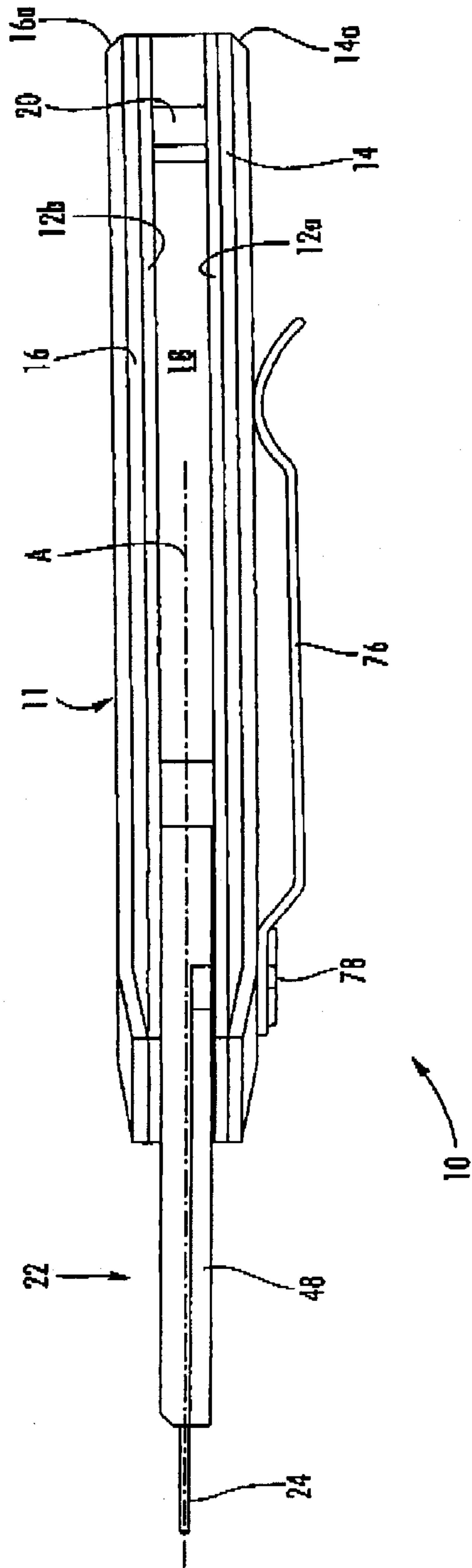

FIG. 1

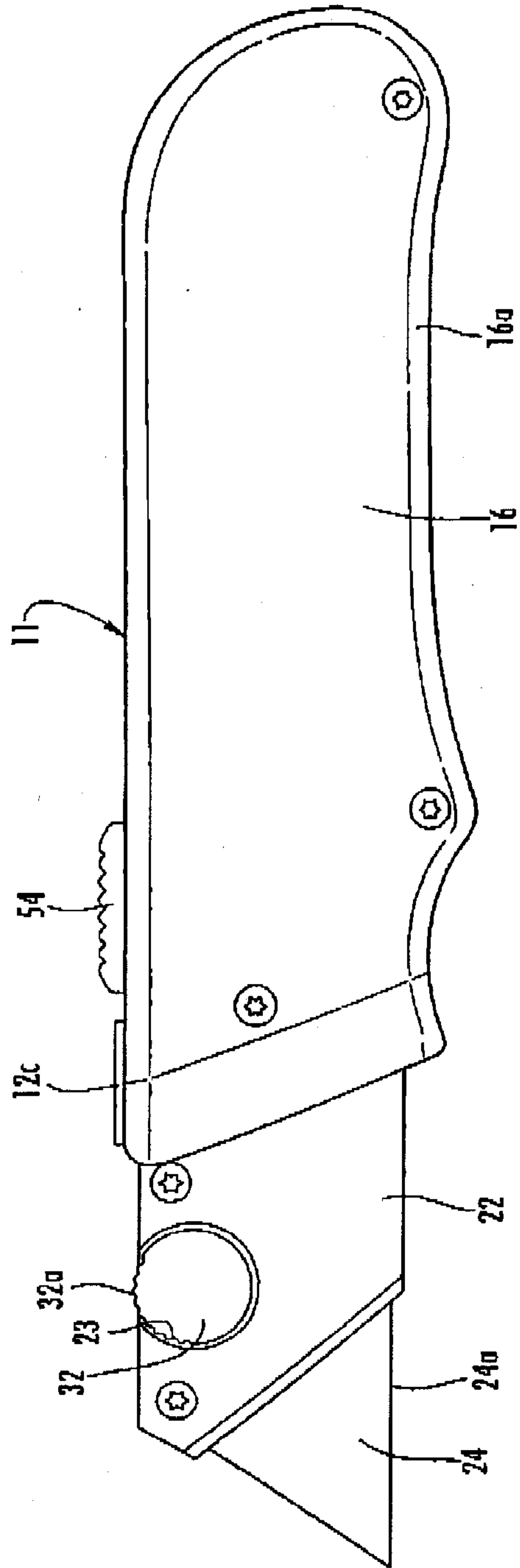

FIG. 2

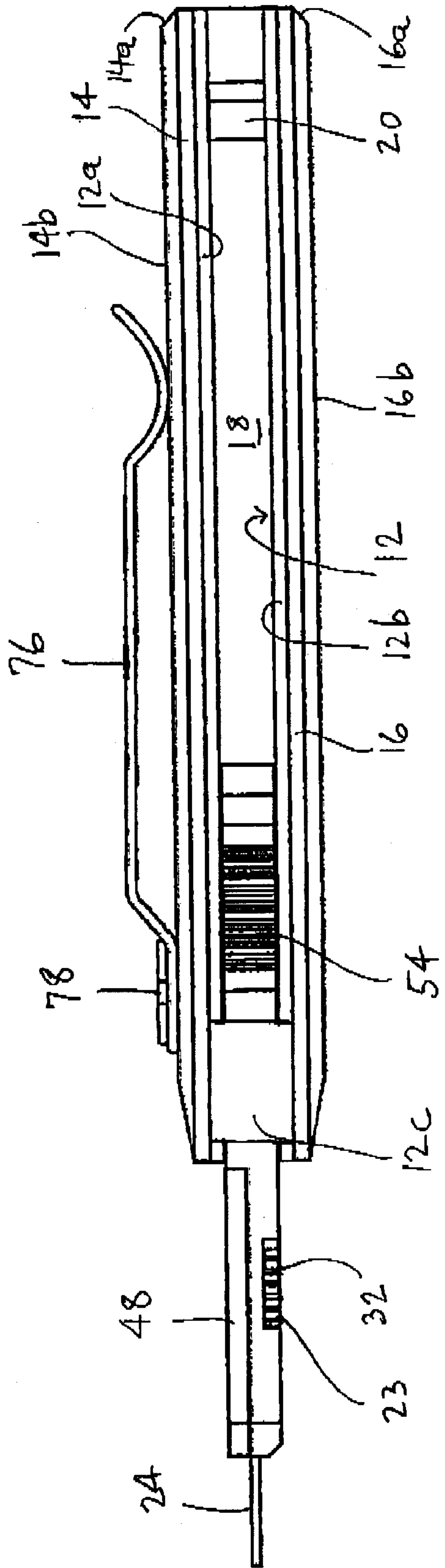

FIG. 3

... ..

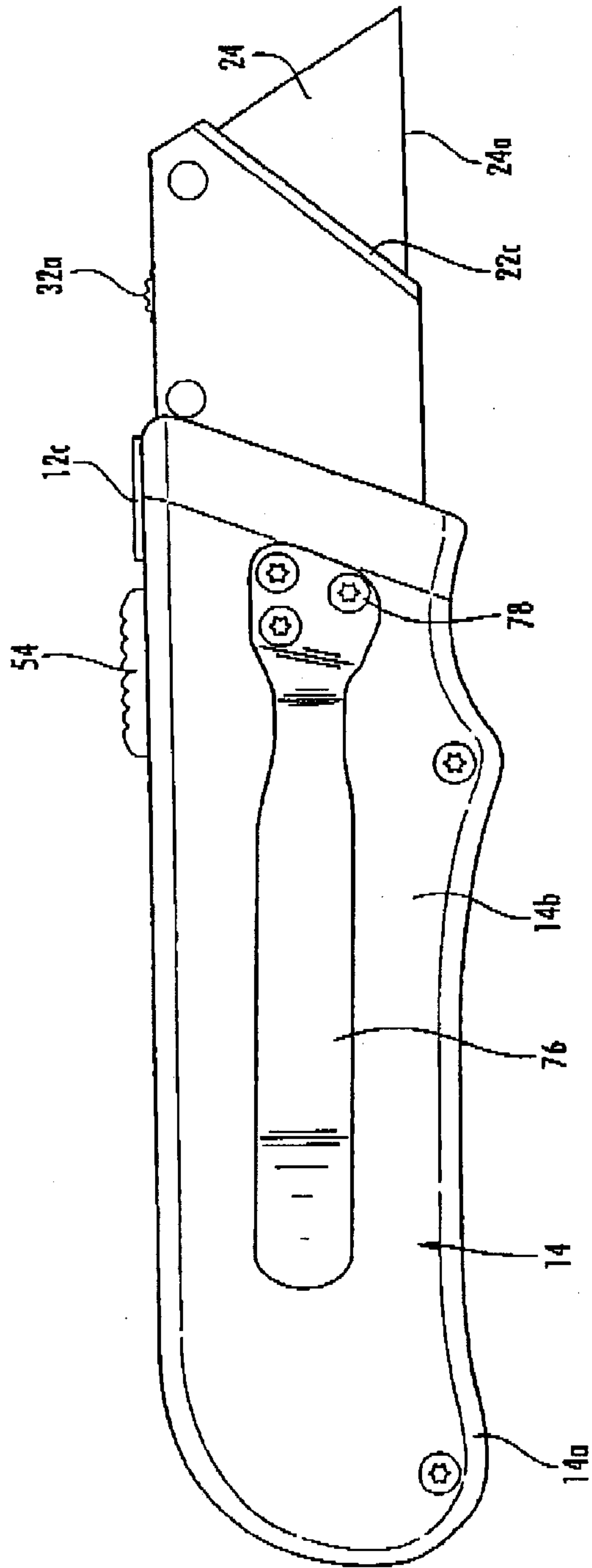
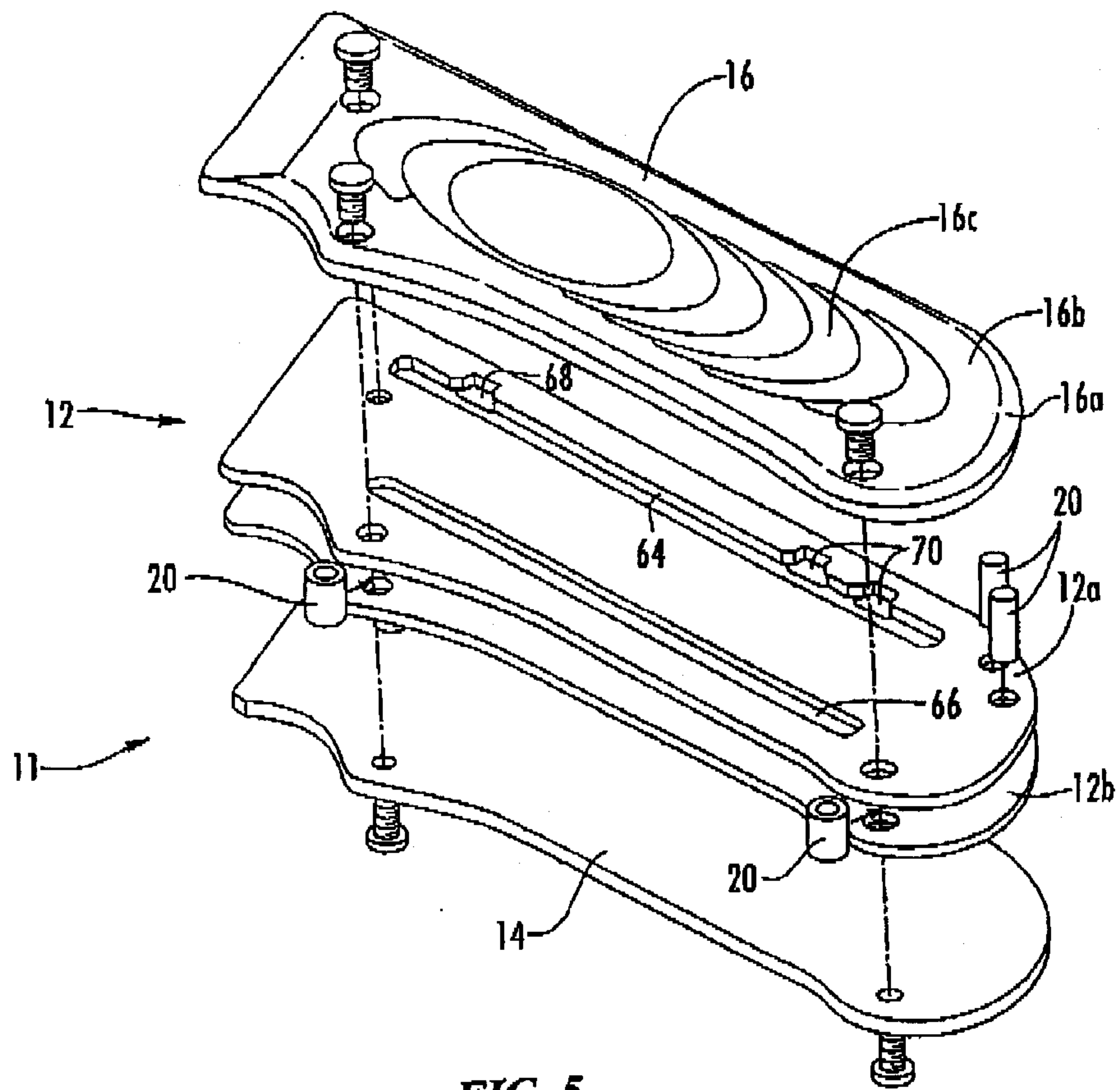
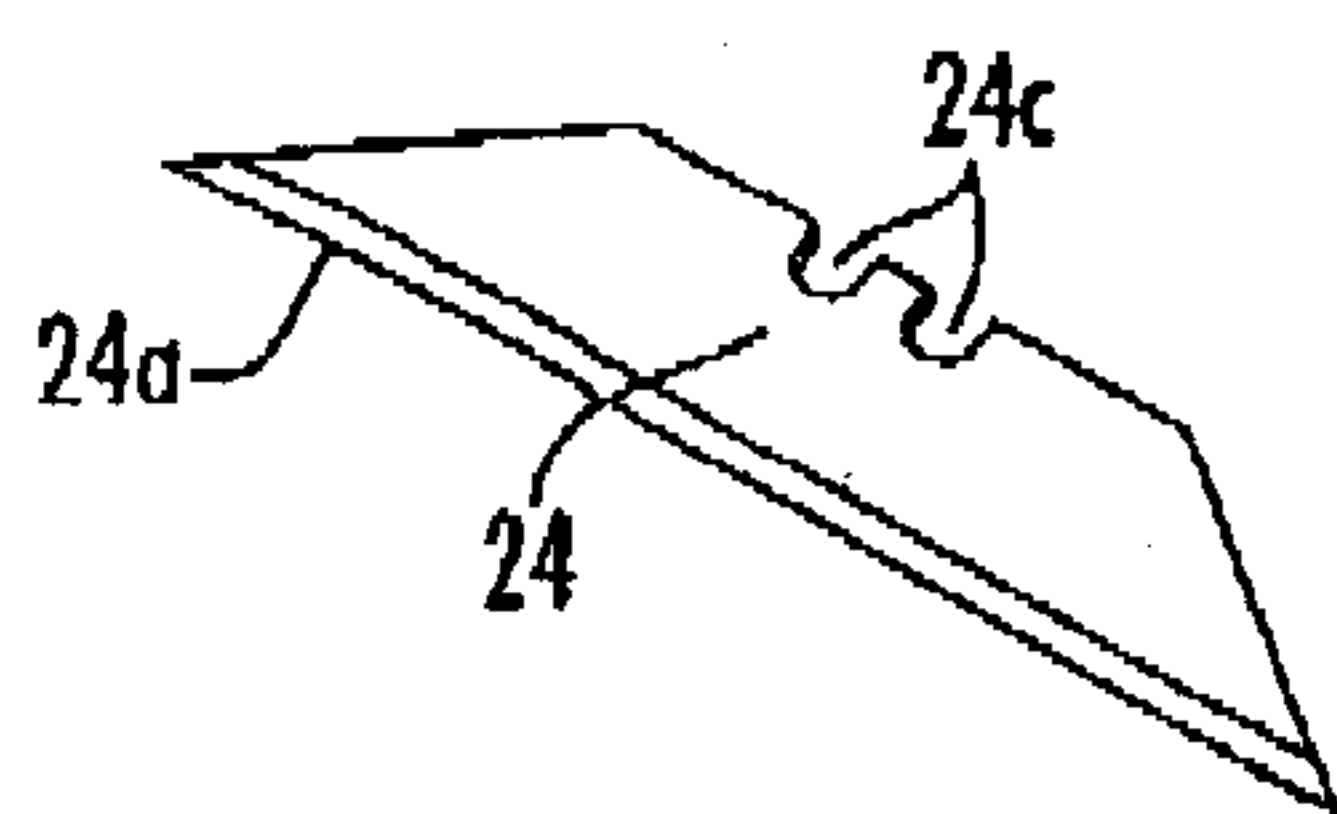

FIG. 4

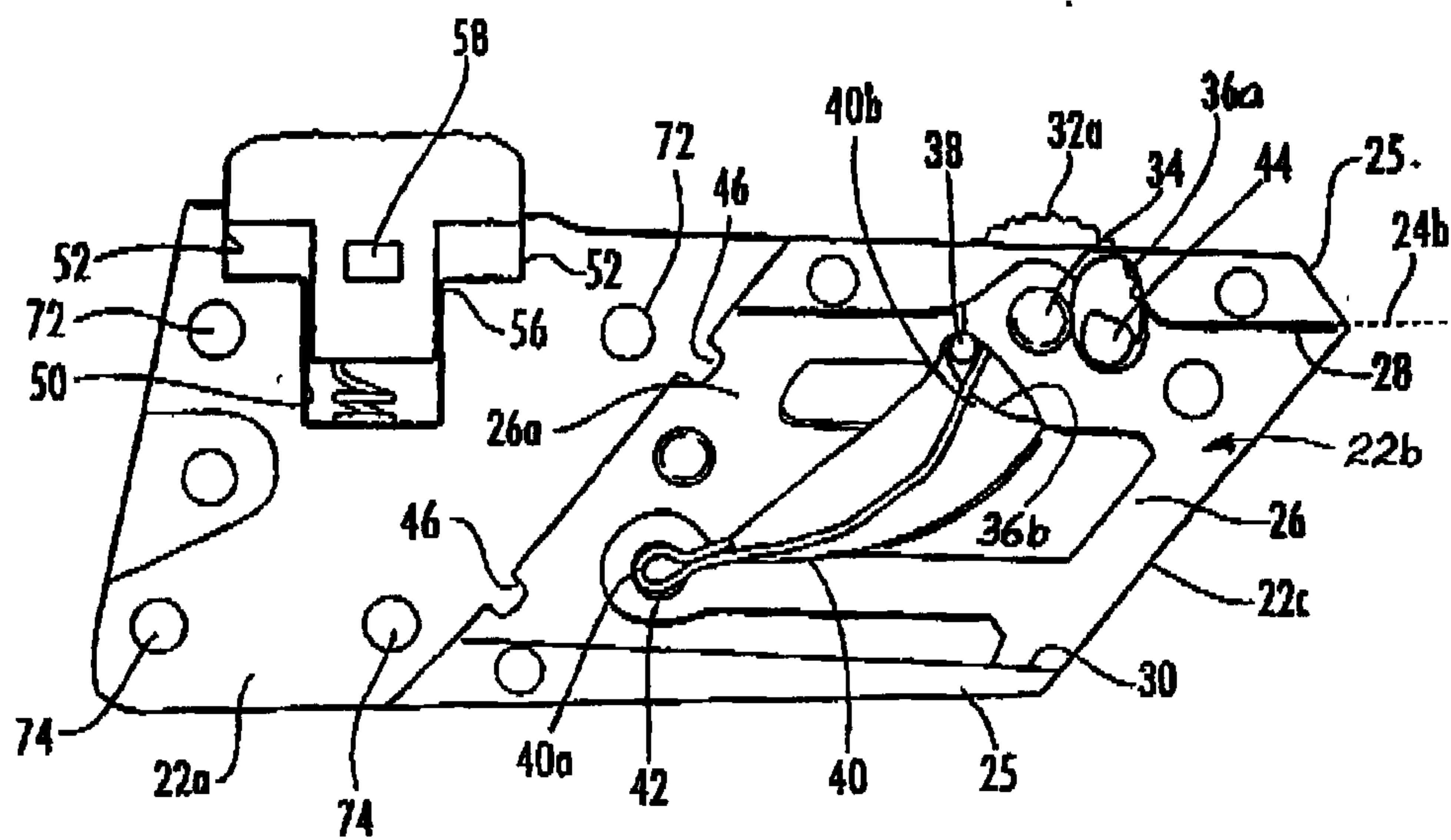
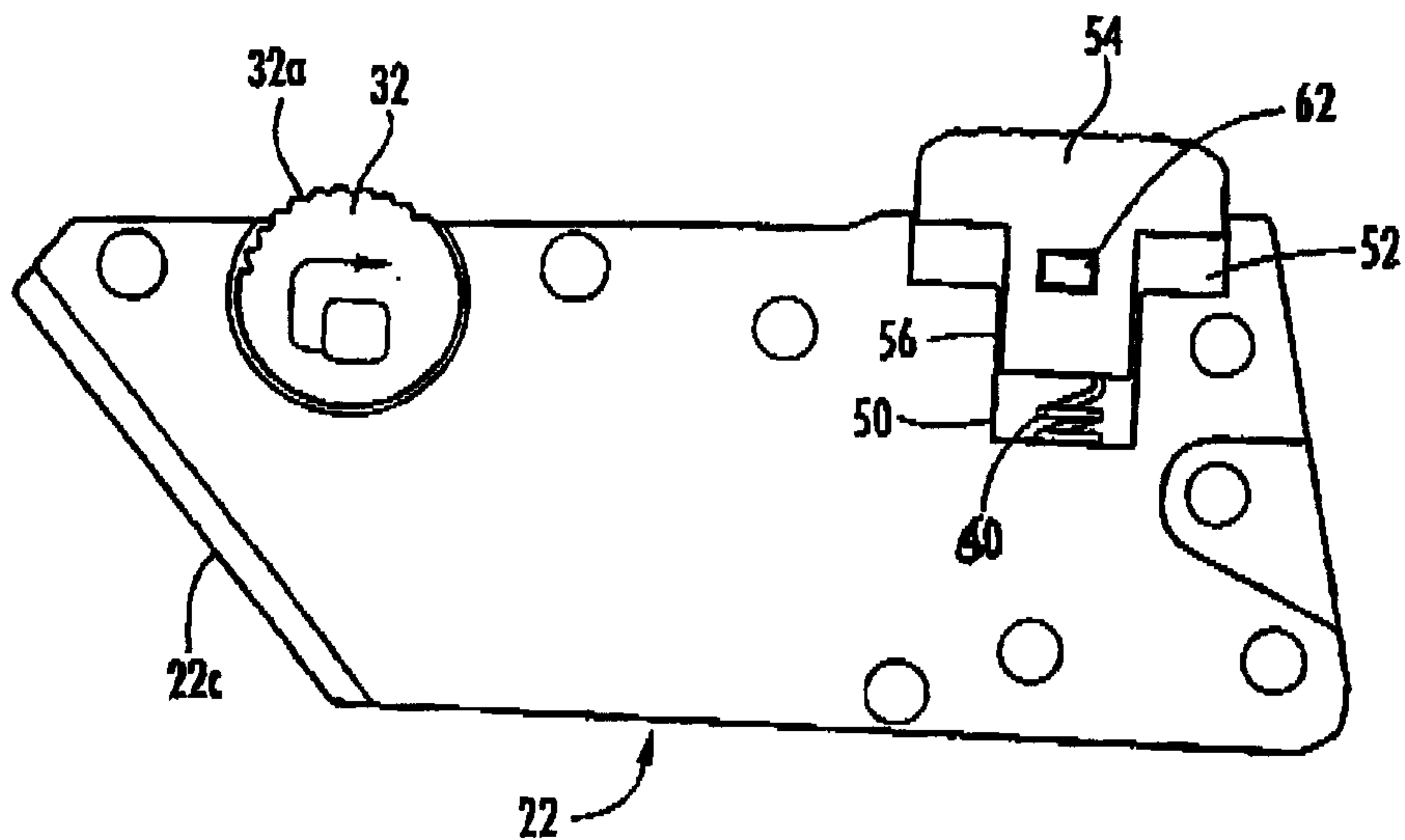

**FIG. 5**

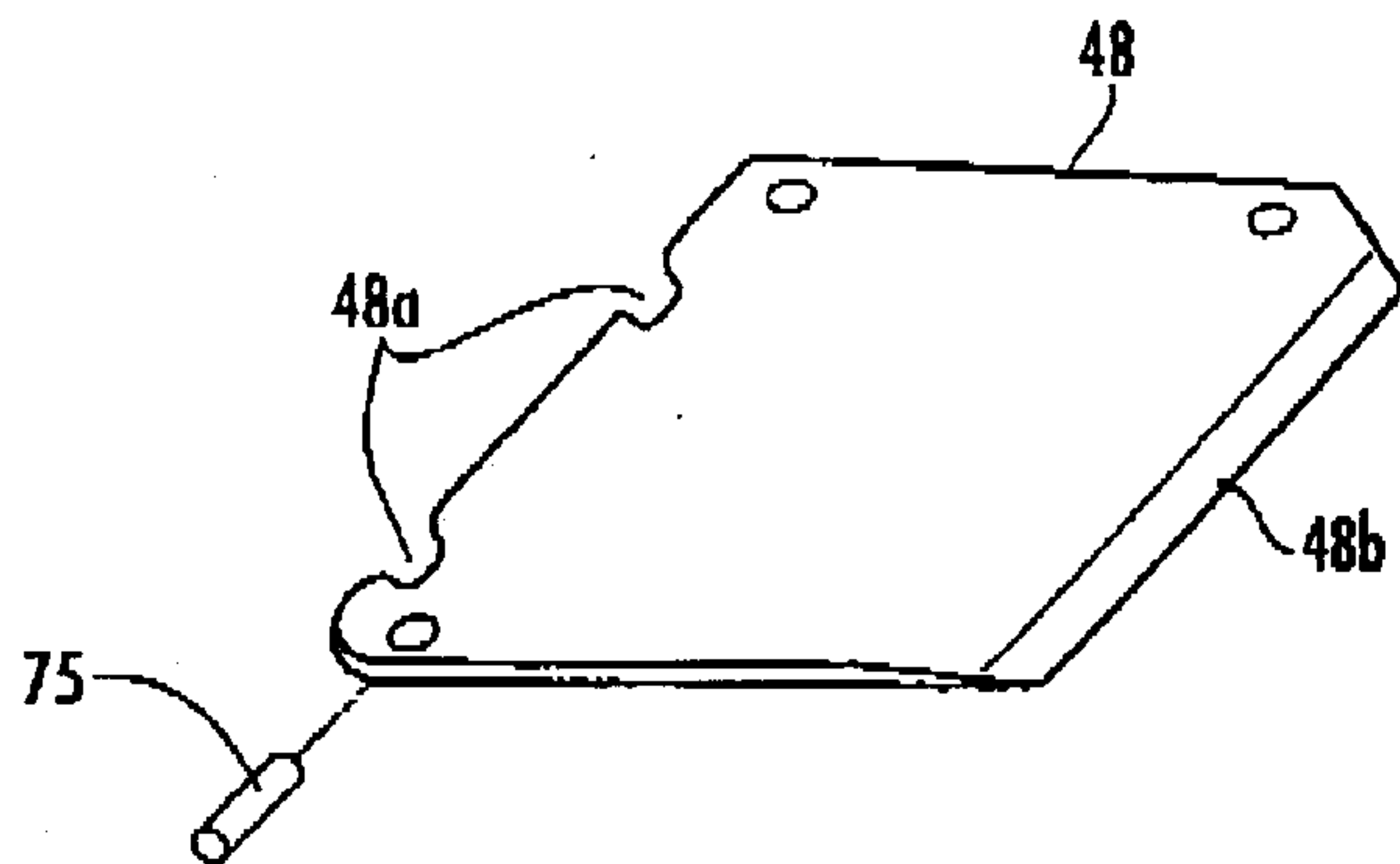

**FIG. 6**

**FIG. 7**



**FIG. 8**



**FIG. 9**



**FIG. 10**

