

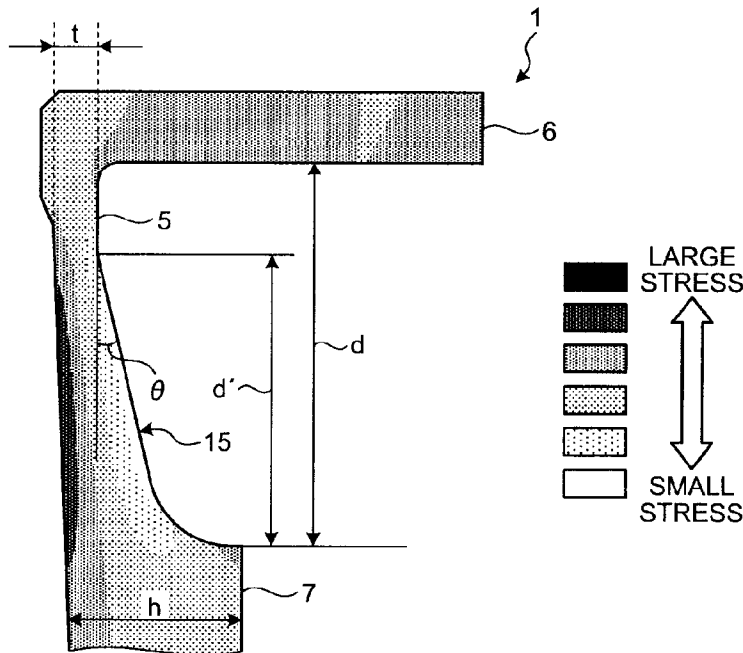

(86) **Date de dépôt PCT/PCT Filing Date:** 2016/05/17  
 (87) **Date publication PCT/PCT Publication Date:** 2017/08/10  
 (45) **Date de délivrance/Issue Date:** 2020/06/09  
 (85) **Entrée phase nationale/National Entry:** 2018/07/31  
 (86) **N° demande PCT/PCT Application No.:** JP 2016/064603  
 (87) **N° publication PCT/PCT Publication No.:** 2017/134843  
 (30) **Priorité/Priority:** 2016/02/04 (JP2016-019997)

(51) **Cl.Int./Int.Cl. F23R 3/42** (2006.01)  
 (72) **Inventeurs/Inventors:**  
 ONISHI, TOMOYUKI, JP;  
 UETSUKI, YASUYUKI, JP;  
 HANADA, TADAYUKI, JP;  
 FUJIMOTO, YOHEI, JP;  
 OTA, TAKAFUMI, JP  
 (73) **Propriétaire/Owner:**  
 MITSUBISHI HEAVY INDUSTRIES AERO ENGINES,  
 LTD., JP  
 (74) **Agent:** SMART & BIGGAR LLP

(54) **Titre : COMPOSANTE D'AERONEF ET TURBINE A GAZ D'AERONEF**  
 (54) **Title: AIRCRAFT COMPONENT AND AIRCRAFT GAS-TURBINE ENGINE**



(57) **Abrégé/Abstract:**

An aircraft component 1 used for an aircraft gas-turbine engine includes: an annular part 5 having an outer circumferential surface; a flange 6 that is formed at one end portion of the annular part 5 in an axial direction; and a boss 7 that projects from the outer circumferential surface of the annular part 5 to the radial direction. On a section cut along an axial direction of the annular part 5, the outer circumferential surface of the annular part 5 between the flange 6 and the boss 7 has a taper part 15 that is formed into a tapered shape in which plate thickness becomes thicker from the flange 6 toward the boss 7.

## ABSTRACT

An aircraft component 1 used for an aircraft gas-turbine engine includes: an annular part 5 having an outer circumferential surface; a flange 6 that is formed at one end portion of the annular part 5 in an axial direction; and a boss 7 that projects from the outer circumferential surface of the annular part 5 to the radial direction. On a section cut along an axial direction of the annular part 5, the outer circumferential surface of the annular part 5 between the flange 6 and the boss 7 has a taper part 15 that is formed into a tapered shape in which plate thickness becomes thicker from the flange 6 toward the boss 7.

## DESCRIPTION

## AIRCRAFT COMPONENT AND AIRCRAFT GAS-TURBINE ENGINE

## Field

[0001] The present invention relates to an annular aircraft  
5 component including a flange and a boss and to an aircraft gas-  
turbine engine.

## Background

[0002] Conventionally, there is a combustion case for a gas-  
turbine engine as an aircraft component (for example, refer to  
10 Patent Literature 1). In this combustion case, an aperture is  
formed, and a boss is formed to enhance the strength of the  
aperture. Forming a T-shaped slot in this boss can provide a  
stress reduction measure such as a measure for relaxing stress  
that is generated in the boss.

## 15 Citation List

## Patent Literature

[0003] Patent Literature 1: Japanese Patent Application Laid-  
open No. 2003-232520

## Summary

20 [0004] In an aircraft component disclosed in Patent Literature  
1, when a T-shaped slot is formed, a band is formed in the  
circumferential direction. Forming a band means making a major  
design change.

[0005] It is an object of the present invention to provide an  
25 aircraft component and an aircraft gas-turbine engine capable of  
reducing stress and extending product life.

[0006] According to an aspect of the present invention, there  
is provided an aircraft component used for an aircraft gas-  
turbine engine, the aircraft component comprising: an annular  
30 part having an outer circumferential surface; a flange that is  
formed at one end portion of the annular part in an axial  
direction; and a boss that projects from the outer

circumferential surface of the annular part to a radial direction, wherein on a section cut along an axial direction of the annular part, the outer circumferential surface of the annular part between the flange and the boss has a taper part that is formed  
5 into a tapered shape in which plate thickness becomes thicker from the flange toward the boss, and when a distance between the flange and the boss in the axial direction of the annular part is defined as  $d$  and a length of the taper part in the axial direction of the annular part is defined as  $d'$ , the length  $d'$  of  
10 the taper part is in a range of  $0.5d \leq d' \leq d$ .

[0006a] According to another aspect of the present invention, there is provided an aircraft component used for an aircraft gas-turbine engine, the aircraft component comprising: an annular part having an outer circumferential surface; a flange that is  
15 formed at one end portion of the annular part in an axial direction; and a boss that projects from the outer circumferential surface of the annular part to a radial direction, wherein on a section cut along an axial direction of the annular part, the outer circumferential surface of the annular part  
20 between the flange and the boss has a taper part that is formed into a tapered shape in which plate thickness becomes thicker from the flange toward the boss, and when a distance between the flange and the boss in the axial direction of the annular part is defined as  $d$ , an inclination angle of the taper part with respect  
25 to the axial direction of the annular part is defined as  $\theta$ , plate thickness of a thinnest portion that is thinnest in the annular part is defined as  $t$ , and plate thickness of the boss is defined as  $h$ , the inclination angle  $\theta$  is in a range of  
 $0.3(h-t)/d \leq \theta \leq (h-t)/d$ .

30 [0007] According to another aspect, an aircraft component used for an aircraft gas-turbine engine includes: an annular part having an outer circumferential surface; a flange that is formed

at one end portion of the annular part in an axial direction; and a boss that projects from the outer circumferential surface of the annular part to the radial direction. On a section cut along an axial direction of the annular part, the outer circumferential surface of the annular part between the flange and the boss has a taper part that is formed into a tapered shape in which plate thickness becomes thicker from the flange toward the boss.

[0007a] This configuration, which includes a taper part, can moderate a change in plate thickness from the flange toward the boss and can moderate a temperature gradient. In addition, this configuration can moderate a change in rigidity of plate thickness from the flange toward the boss. Thus, stress generated around the boss can be reduced and product life can be extended.

[0008] Preferably, in some embodiments, when a distance between the flange and the boss in the axial direction of the annular part is defined as  $d$  and a length of the taper part in the axial direction of the annular part is defined as  $d'$ , the length  $d'$  of the taper part is in a range of  $0.5d \leq d' \leq d$ .

[0009] This configuration enables a length of the taper part to be made suitable, thereby suitably reducing stress.

[0010] Preferably, in some embodiments, when a distance between the flange and the boss in the axial direction of the annular part is defined as  $d$ , an inclination angle of the taper part with respect to the axial direction of the annular part is defined as  $\theta$ , plate thickness of a thinnest portion that is thinnest in the annular part is defined as  $t$ , and plate thickness of the boss is defined as  $h$ , the inclination angle  $\theta$  is in a range of  $0.3(h-t)/d \leq \theta \leq (h-t)/d$ .

[0011] This configuration enables an inclination angle of the taper part to be made suitable, thereby suitably reducing stress.

[0012] Preferably, in some embodiments, the flange is formed

to extend in a circumferential direction of the annular part, and the boss has a portion facing the flange and formed parallel to the flange.

[0013] This configuration increases an area of the taper part  
5 formed between the flange and the boss, thereby suitably reducing stress.

[0014] Preferably, in some embodiments, when a width of a  
portion of the boss parallel to the flange is defined as  $a$  and a  
curvature radius of a circumferential edge of the boss centering  
10 a bolt-hole that is formed by penetrating the boss is defined as  
 $b$ , the width  $a$  of the portion of the boss is in a range of  $b < a < 3b$ .

[0015] This configuration enables a width of the boss to be  
made suitable, thereby suitably reducing stress.

15 [0016] According to another aspect of the present invention,  
an aircraft gas-turbine engine includes the aircraft component.

[0017] This configuration enables the aircraft component  
suitably reducing stress to be employed, thereby enhancing  
reliability of the aircraft gas-turbine engine.

#### 20 Brief Description of Drawings

[0018] FIG. 1 is a view illustrating an aircraft component  
according to an embodiment.

FIG. 2 is a sectional view when the aircraft component  
according to the embodiment is cut along an axial direction.

25 FIG. 3 is an explanatory drawing illustrating an example of  
comparing thermal stress of the aircraft component according to  
the embodiment with thermal stress of a conventional aircraft  
component.

30 FIG. 4 is an explanatory drawing illustrating an example of  
comparing thermal stress of the aircraft component according to  
the embodiment with thermal stress of the conventional aircraft  
component.

#### Description of Embodiment

[0019] An embodiment according to the present invention will now be described in detail with reference to the accompanying drawings. It should be noted that the embodiment is not intended to limit the present invention. Components in the embodiment include components that can be replaced and are facilitated by the skilled person or substantially like components. In addition, components described below can be combined as appropriate.

5  
10 Furthermore, when there are a plurality of embodiments, each of the embodiments can be combined.

#### [0020] Embodiment

An aircraft component according to the embodiment is used for an aircraft gas-turbine engine, and is, for example, a component forming a casing of a combustor. FIG. 1 is a view illustrating an aircraft component according to the embodiment. FIG. 2 is a sectional view when the aircraft component according to the embodiment is cut along an axial direction. FIGS. 3 and 4 are explanatory drawings illustrating an example of comparing thermal stress of the aircraft component according to the embodiment with thermal stress of a conventional aircraft component. The following describes a case when the embodiment is applied as an aircraft component to a casing of a combustor, but this is not especially limiting. The embodiment may be applied to any aircraft component.

[0021] An aircraft component 1 includes an annular part 5, a flange 6, and a boss 7. The annular part 5 is formed in an annular shape in the circumferential direction when setting a predetermined direction as an axial direction, and the boss 7 is formed on an outer circumferential surface of the annular part 5. The flange 6 is provided to one end portion of the annular part 5, projects to the

outside in the radial direction, and is provided over the whole circumference to extend in the circumferential direction. The boss 7 is formed to project from an outer circumferential surface of the annular part 5 to the outside in the radial direction.

[0022] The boss 7 has circular through-holes 10 formed therein for communicating with the inside and the outside. To the through-holes 10, fuel piping not illustrated for supplying fuel is connected. The boss 7 has a plurality of bolt-holes 11 formed therein around the through-holes 10 for fastening the fuel piping to the aircraft component 1.

[0023] The boss 7 is formed to have a thickness thicker than a thinnest portion of the annular part 5. In the boss 7, portions facing the flange 6 are formed parallel to the flange 6. In other words, circumferential edge portions of the boss 7 facing the flange 6 are each formed in a linear shape so as to be parallel to the flange 6.

[0024] A width of a portion of the boss 7 facing the flange 6, in other words, a width of a portion of the boss 7 in the circumferential direction is defined as  $a$ . A curvature radius of the circumferential edge of the boss 7 centering the bolt-hole 11 that is formed by penetrating the boss 7 is defined as  $b$ . Specifically, a width of a portion of the boss 7 on the left side in FIG. 1 is defined as  $a_1$ , and a curvature radius of the circumferential edge of the boss 7 on the left side in FIG. 1 is defined as  $b_1$ . A width of a portion of the boss 7 on the right side in FIG. 1 is defined as  $a_2$ , and a curvature radius of the circumferential edge of the boss 7 on the right side in FIG. 1 is defined as  $b_2$ . In this case, the widths  $a_1$  and  $a_2$  of the boss 7 are in the range of  $b_1 < a_1 < 3b_1$  and of  $b_2 < a_2 < 3b_2$ , respectively.

[0025] As illustrated in FIG. 2, the aircraft component

1 has, on a section (section along A-A in FIG. 1) cut along an axial direction of the annular part 5, a taper part 15 between the flange 6 and the boss 7. In the taper part 15, a shape of an outer circumferential surface of the annular part 5 between the flange 6 and the boss 7 is formed into a tapered shape in which plate thickness becomes thicker from the flange 6 toward the boss 7. A surface that becomes a tapered shape is linearly formed on a section cut along an axial direction of the annular part 5.

10 [0026] A distance between the flange 6 and the boss 7 in an axial direction of the annular part 5 is defined as  $d$ . A length of the taper part 15 in an axial direction of the annular part 5 is defined as  $d'$ . In this case, the length  $d'$  of the taper part 15 is in the range of  $0.5d \leq d' \leq d$ .

15 [0027] An inclination angle  $\theta$  of the taper part 15 with respect to an axial direction of the annular part 5 is in the following range. Plate thickness of the thinnest portion that is thinnest in the annular part 5 is defined as  $t$ , and plate thickness of the boss 7 is defined as  $h$ .

20 In this case, the inclination angle  $\theta$  is in the range of  $0.3(h-t)/d \leq \theta \leq (h-t)/d$ .

[0028] With reference to FIGS. 3 and 4, stress distribution of a conventional aircraft component 1 is compared with stress distribution of the aircraft component 1 according to the embodiment. Stress indicates thermal stress generated by difference in temperature between the inside and the outside of the annular part 5. The conventional aircraft component 1 is not provided with the taper part 15, and the shape of a portion of the boss 7 facing the flange 6 is a mountainous shape projecting toward the flange 6 side.

[0029] As illustrated in FIG. 3, in the conventional aircraft component 1, stress is larger at the annular part

5 between the flange 6 and the boss 7, especially on a base side of the boss 7. By contrast, in the aircraft component 1 according to the embodiment, it has been confirmed that stress is relaxed at the taper part 15 between the flange 6 and the boss 7. As illustrated in FIG. 4 (section along A-A in FIG. 3), in the conventional aircraft component 1, stress on front and rear sides of the annular part 5 is larger at the annular part 5 between the flange 6 and the boss 7, especially on a base side of the boss 7. By contrast, in the aircraft component 1 according to the embodiment, it has been confirmed that stress on front and rear sides of the taper part 15 is relaxed at the taper part 15 between the flange 6 and the boss 7.

[0030] As described above, according to the embodiment, the taper part 15 is provide between the flange 6 and the boss 7. This configuration can moderate a change in plate thickness from the flange 6 toward the boss 7, and can moderate a temperature gradient. In addition, this configuration can moderate a change in rigidity of plate thickness from the flange 6 toward the boss 7. Thus, stress generated around the boss 7 can be reduced and product life can be extended.

[0031] According to the embodiment, the length  $d'$  of the taper part 15, the inclination angle  $\theta$  of the taper part 15, and the widths  $a_1$  and  $a_2$  of the boss 7 can be set in a suitable range, thereby suitably reducing stress.

[0032] According to the embodiment, a portion of the boss 7 facing the flange 6 is formed parallel to the flange 6. This increases an area of the taper part 15 formed between the flange 6 and the boss 7, thereby suitably reducing stress.

[0033] According to the embodiment, the aircraft component 1 suitably reducing stress can be applied to an

aircraft gas-turbine engine, thereby improving reliability of the aircraft gas-turbine engine.

Reference Signs List

- [0034] 1 AIRCRAFT COMPONENT
- 5 5 ANNULAR PART
- 6 FLANGE
- 7 BOSS
- 10 THROUGH-HOLE
- 11 BOLT-HOLE
- 10 15 TAPER PART

CLAIMS:

1. An aircraft component used for an aircraft gas-turbine engine, the aircraft component comprising:

5 an annular part having an outer circumferential surface;  
a flange that is formed at one end portion of the annular part in an axial direction; and

a boss that projects from the outer circumferential surface of the annular part to a radial direction, wherein

10 on a section cut along an axial direction of the annular part, the outer circumferential surface of the annular part between the flange and the boss has a taper part that is formed into a tapered shape in which plate thickness becomes thicker from the flange toward the boss, and

15 when a distance between the flange and the boss in the axial direction of the annular part is defined as  $d$  and a length of the taper part in the axial direction of the annular part is defined as  $d'$ , the length  $d'$  of the taper part is in a range of  $0.5d \leq d' \leq d$ .

20

2. The aircraft component according to claim 1, wherein when a distance between the flange and the boss in the axial direction of the annular part is defined as  $d$ , an inclination angle of the taper part with respect to the axial direction of the annular part is defined as  $\theta$ , plate thickness of a thinnest portion that is thinnest in the annular part is defined as  $t$ , and plate thickness of the boss is defined as  $h$ , the inclination angle  $\theta$  is in a range of  $0.3(h-t)/d \leq \theta \leq (h-t)/d$ .

25

30 3. An aircraft component used for an aircraft gas-turbine engine, the aircraft component comprising:  
an annular part having an outer circumferential surface;

a flange that is formed at one end portion of the annular part in an axial direction; and

a boss that projects from the outer circumferential surface of the annular part to a radial direction, wherein

5 on a section cut along an axial direction of the annular part, the outer circumferential surface of the annular part between the flange and the boss has a taper part that is formed into a tapered shape in which plate thickness becomes thicker from the flange toward the boss, and

10 when a distance between the flange and the boss in the axial direction of the annular part is defined as  $d$ , an inclination angle of the taper part with respect to the axial direction of the annular part is defined as  $\theta$ , plate thickness of a thinnest portion that is thinnest in the annular part is defined as  $t$ , and  
15 plate thickness of the boss is defined as  $h$ , the inclination angle  $\theta$  is in a range of  $0.3(h-t)/d \leq \theta \leq (h-t)/d$ .

4. The aircraft component according to any one of claims 1 to 3, wherein

20 the flange is formed to extend in a circumferential direction of the annular part, and

the boss has a portion facing the flange and formed parallel to the flange.

25 5. The aircraft component according to claim 4, wherein when a width of the portion of the boss parallel to the flange is defined as  $a$  and a curvature radius of a circumferential edge of the boss centering a bolt-hole that is formed by penetrating the boss is defined as  $b$ , the width  $a$  is in a range of  $b < a < 3b$ .

30

6. An aircraft gas-turbine engine comprising the aircraft component according to any one of claims 1 to 5.

FIG.1

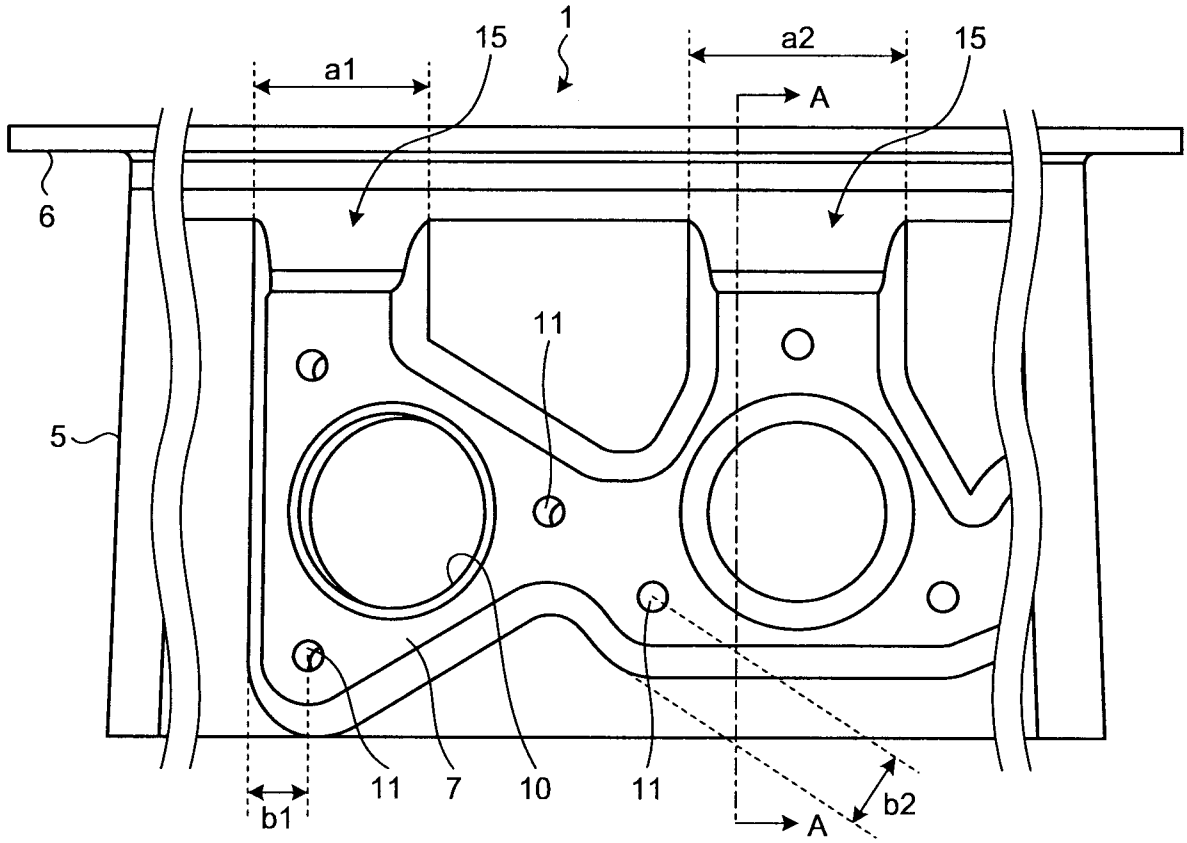

FIG.2

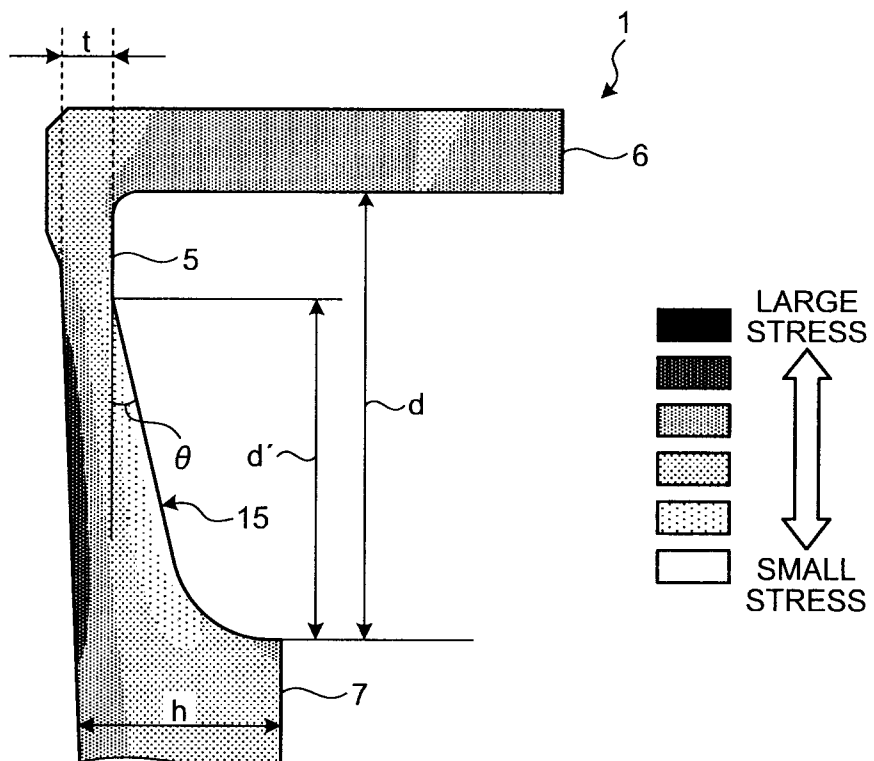

FIG.3

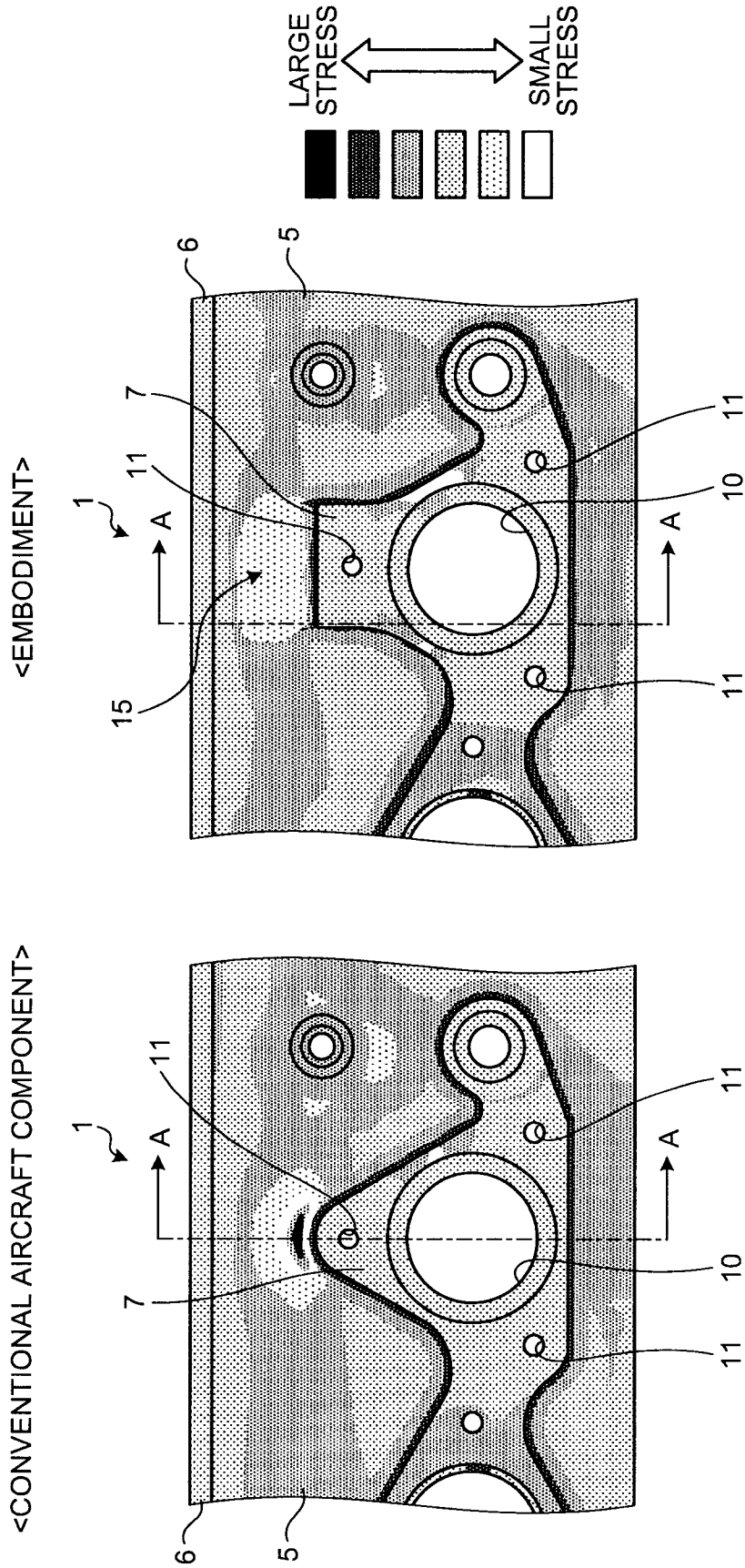
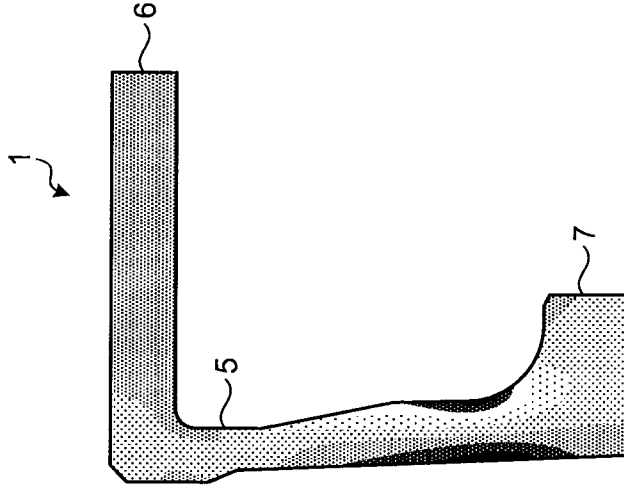
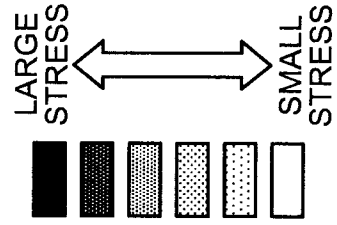
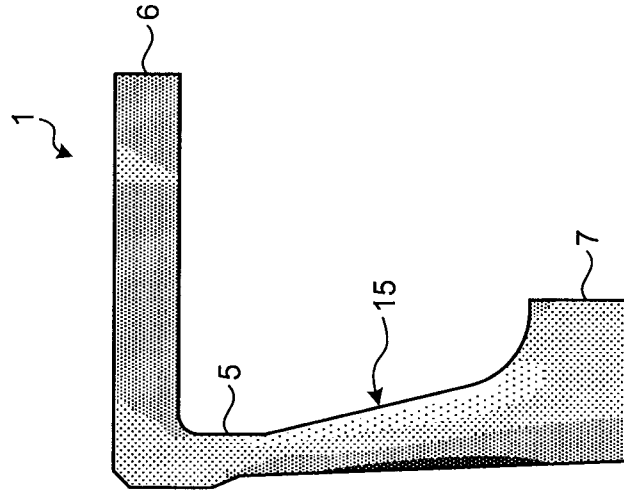

FIG.4

<CONVENTIONAL AIRCRAFT COMPONENT>



<EMBODIMENT>



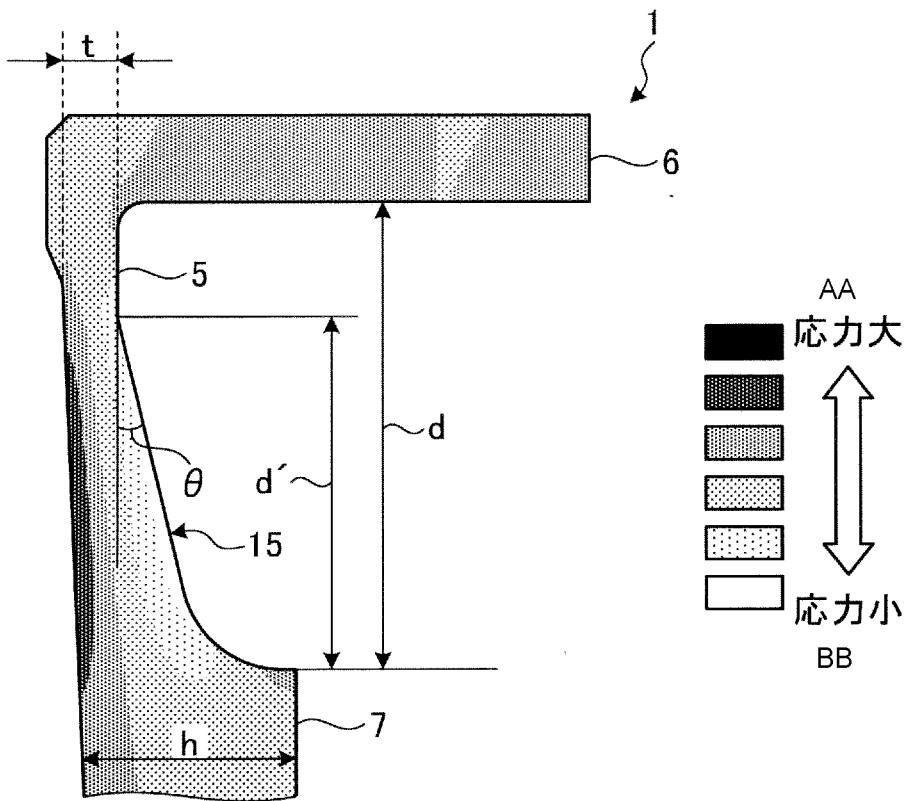

AA Greater stress  
 BB Smaller stress