

(No Model.)

W. BRAND.  
BOILER AND BOILER FURNACE.

No. 569,996

Patented Oct. 27, 1896.

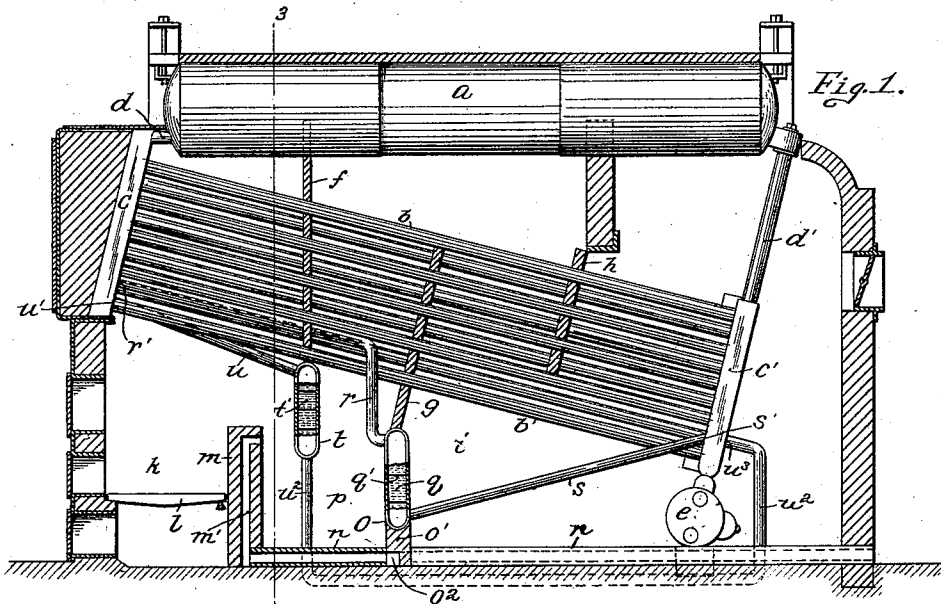

Fig. 1.

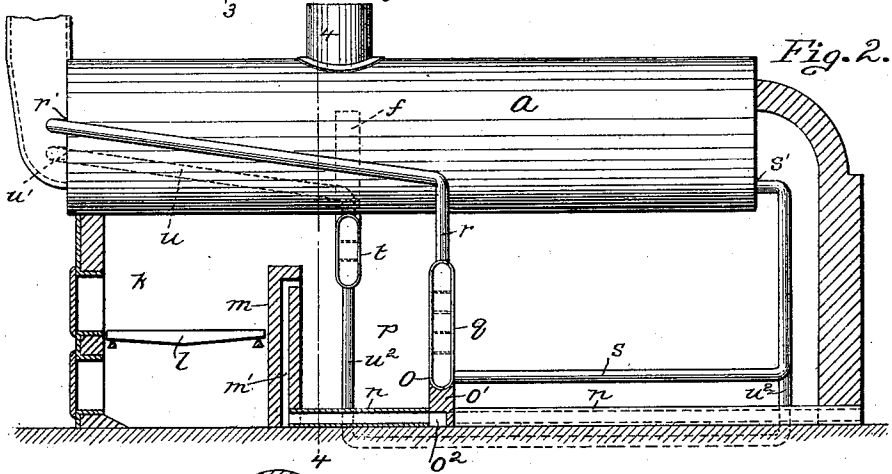

Fig. 2.

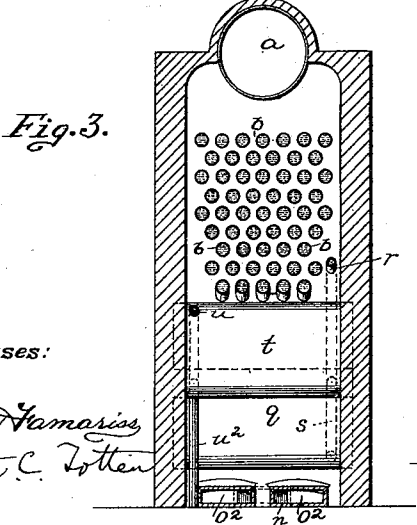

Fig. 3.

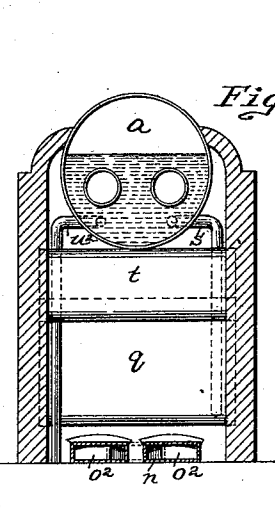

Fig. 4.

Witnesses:

Walter J. Harris  
Robert C. Totten

Inventor:  
William Brand  
By Kay & Yetter  
Attorneys.

# UNITED STATES PATENT OFFICE.

WILLIAM BRAND, OF PITTSBURG, PENNSYLVANIA.

## BOILER AND BOILER-FURNACE.

SPECIFICATION forming part of Letters Patent No. 569,996, dated October 27, 1896.

Application filed January 23, 1896. Serial No. 576,487. (No model.)

*To all whom it may concern:*

Be it known that I, WILLIAM BRAND, a resident of Pittsburg, in the county of Allegheny and State of Pennsylvania, have invented a new and useful Improvement in Boilers and Boiler-Furnaces; and I do hereby declare the following to be a full, clear, and exact description thereof.

My invention relates to boilers and boiler-furnaces, its object being to create an active circulation and at the same time to provide a boiler-furnace in which a thorough combustion takes place.

To enable others skilled in the art to make and use my invention, I will describe the same more fully, referring to the accompanying drawings, in which—

Figure 1 is a longitudinal section of a boiler and furnace embodying my invention. Fig. 2 is a like view of the invention as applied to a smoke-flue boiler. Fig. 3 is a section on the line 3 3, Fig. 1; and Fig. 4 is a section on the line 4 4, Fig. 2.

Like letters indicate like parts in each of the figures.

My invention is applicable to many forms of boilers, and I have illustrated it as applied to both the common form of water-tube boiler and smoke-flue boiler.

Figs. 1 and 3 represent my invention as applied to the water-tube boiler. This boiler is in principal features a Babcock and Wilcox boiler, consisting of the drum *a* and the inclined water-tubes *b*, connected to the headers *c c'*. These headers *c c'* are in communication with the drum *a* through the pipes *d d'*. The mud-drum *e* is located at the lower end of the header *c'* in the ordinary manner. The baffle-walls *f g h* cause the heated products to pass in an indirect course up and down through the tubes *b* on their way to the stack or chimney, so that the tubes *b* are all highly heated by said products of combustion. All these parts are contained within the furnace *i*, which is provided with the ordinary charging and cleaning doors, &c.

At the front of the furnace *i* is the fuel-chamber *k*, provided with the grate-bars *l*. Beyond the grate-bars *l* is the bridge-wall *m*, said bridge-wall having the passage *m'* formed therein, communicating with the furnace-chamber at the upper end thereof. The lower

end of the passage *m'* is in communication with the flue *n*, which extends to the rear end of the furnace, where it communicates with the open air. In this manner air is emitted from the upper end of the bridge-wall *m* to commingle with the products of combustion as they come from the fuel-chamber *k*. Beyond the bridge-wall *m* is the rear bridge-wall *o*, the space between the two walls forming the combustion-chamber *p*.

The rear bridge-wall *o* will now be described in detail. It consists of the brick foundation *o'* with the arched openings *o''* therein, through which the flue *n* passes. Supported on this foundation *o'* is the water-chamber *q*, constructed of sheet metal of proper thickness. The said water-chamber *q* may be formed in any suitable manner to give it the requisite strength, and is provided with the stay-bolts *q'*. The water-chamber *q* is further supported by fitting its ends within recesses formed to receive it in the walls of the furnace. The baffle-wall *g* extends up from the bridge-wall *o*. Leading from one side of the water-chamber *q*, at the upper end thereof, is the pipe *r*, said pipe extending upwardly and forwardly to the front end of the furnace-chamber, where it connects with the header *c* at *r'*. This pipe *r* being within the furnace-chamber and at the forward or hottest part of said chamber is of course subjected to a high heat and will serve as an uptake-pipe. The second pipe *s* leads from the lower end of the water-chamber *q* directly back to the header *c'*, entering said header at *s'*. I do not limit myself, however, to the above-described arrangements of the pipes *r* and *s*, as they may be arranged in different ways according to the circumstances. Nor do I limit myself to the use of two pipes, as the number may be increased.

Between the two bridge-walls *m* and *o* is the depending wall *t*, which also consists of the water-chamber *t'*, constructed like the water-chamber *q*. This wall *t* is supported within recesses in the sides of the furnace and so forms an extension of the downwardly-projecting baffle-wall *f*. Leading from the upper end of the water-chamber *t'* is the pipe *u*, said pipe extending up within the furnace-chamber to the header *c* of the boiler, which it enters at *u'*. This pipe also is an uptake-pipe,

as it is exposed to the high heat of the front part of the furnace. Leading from the lower end of the water-chamber *t'* is the pipe *u<sup>2</sup>*, which passes down through the furnace to the header *c'*, which it enters at *u<sup>3</sup>*. This arrangement of the pipes *u* and *u<sup>2</sup>* may also be varied to suit circumstances.

When the invention is applied to the type of boilers shown in Fig. 1, the heated products of combustion coming from the fuel-chamber strike the baffle *f* and depending wall *t*, by which they are carried down into the combustion-chamber *p*. A fresh supply of air is added to the heated products as they pass down into the combustion-chamber. The gases and air become highly heated by contact with the heated surfaces both of the fire-chamber *m* and depending wall *o*, and as they unite with each other form a very high heat within the combustion-chamber *p*. The heated products then pass up from the combustion-chamber *p* in between the tubes *b*, and thence are directed down between the tubes again by the rear baffle *h*. The tubes *b* are thus, of course, highly heated and at the same time the depending wall *t* and bridge-wall *o*.

The main circulation in the boiler after it has become heated properly is from the drum *a* down the pipe *d'* to the header *c'*, thence up through the tubes *b* to the header *c*, and thence by the pipe *d* back into the drum *a*. This circulation is kept up constantly while the furnace is in operation. Besides this main circulation there are two additional circulations through the water-chambers *q* and *t'*. The water will pass from the header *c'* through the pipe *s* to the water-chamber *q* and from the

water-chamber *q* by the uptake-pipe *r* into the header *c*, and thence to the drum *a*. The other circulation is from the header *c'*, through the pipe *u<sup>2</sup>*, to the water-chamber *t'*, and thence by the pipe *u* to the header *c*. In this manner the rear bridge-wall *o* and depending wall *t* not only act to create a greater heat under the boiler with less fuel, but by forming the water-chambers in them I obtain two additional circulations, so that the efficiency of the boiler is greatly increased, while the circulation throughout is made more active, which prevents the accumulation of scale.

Figs. 2 and 4 show the invention as applied to a common form of smoke-flue boiler, and as the operation is the same as described with reference to Figs. 1 and 3 no detailed description is deemed necessary.

By the use of my invention I am enabled to create a circulation in an ordinary smoke-flue boiler.

What I claim as my invention, and desire to secure by Letters Patent, is—

In a boiler-furnace, the combination with a boiler of a fuel-chamber at the front end thereof having a bridge-wall, a bridge-wall in the rear of said first-mentioned wall having a water-chamber therein, a depending wall between said bridge-walls having a water-chamber therein, and circulating-pipes connecting said water-chambers to the boiler, substantially as set forth.

In testimony whereof I, the said WILLIAM BRAND, have hereunto set my hand.

WILLIAM BRAND.

Witnesses:

ROBT. D. TOTTEN,  
ROBERT C. TOTTEN.