



US 20080133006A1

(19) **United States**

(12) **Patent Application Publication**
Crosby et al.

(10) **Pub. No.: US 2008/0133006 A1**

(43) **Pub. Date: Jun. 5, 2008**

(54) **BLOOD PUMP WITH AN ULTRASONIC TRANSDUCER**

(22) Filed: **Oct. 25, 2007**

(75) Inventors: **Peter Andrew Crosby**, Manly (AU); **Colin Neville Sutton**, Newport (AU); **Peter Joseph Ayre**, Crows Nest (AU)

(30) **Foreign Application Priority Data**

Oct. 27, 2006 (AU) 2006905998

Publication Classification

(51) **Int. Cl.**
A61M 1/10 (2006.01)

(52) **U.S. Cl.** **623/3.13; 600/17; 415/900**

Correspondence Address:
MCCARTER & ENGLISH , LLP STAMFORD OFFICE
FINANCIAL CENTRE , SUITE 304A, 695 EAST MAIN STREET
STAMFORD, CT 06901-2138

(57) **ABSTRACT**

A blood pump including a ultrasonic sensor mounted in or on a blood contacting surface of said blood pump. The ultrasonic sensor measures blood velocity and reports information to a blood pump controller and wherein the ultrasonic sensor is directed to measure blood velocity in an inflow cannula connected to the blood pump.

(73) Assignee: **VENTRASSIST PTY LTD**, Chatsworth (AU)

(21) Appl. No.: **11/924,124**

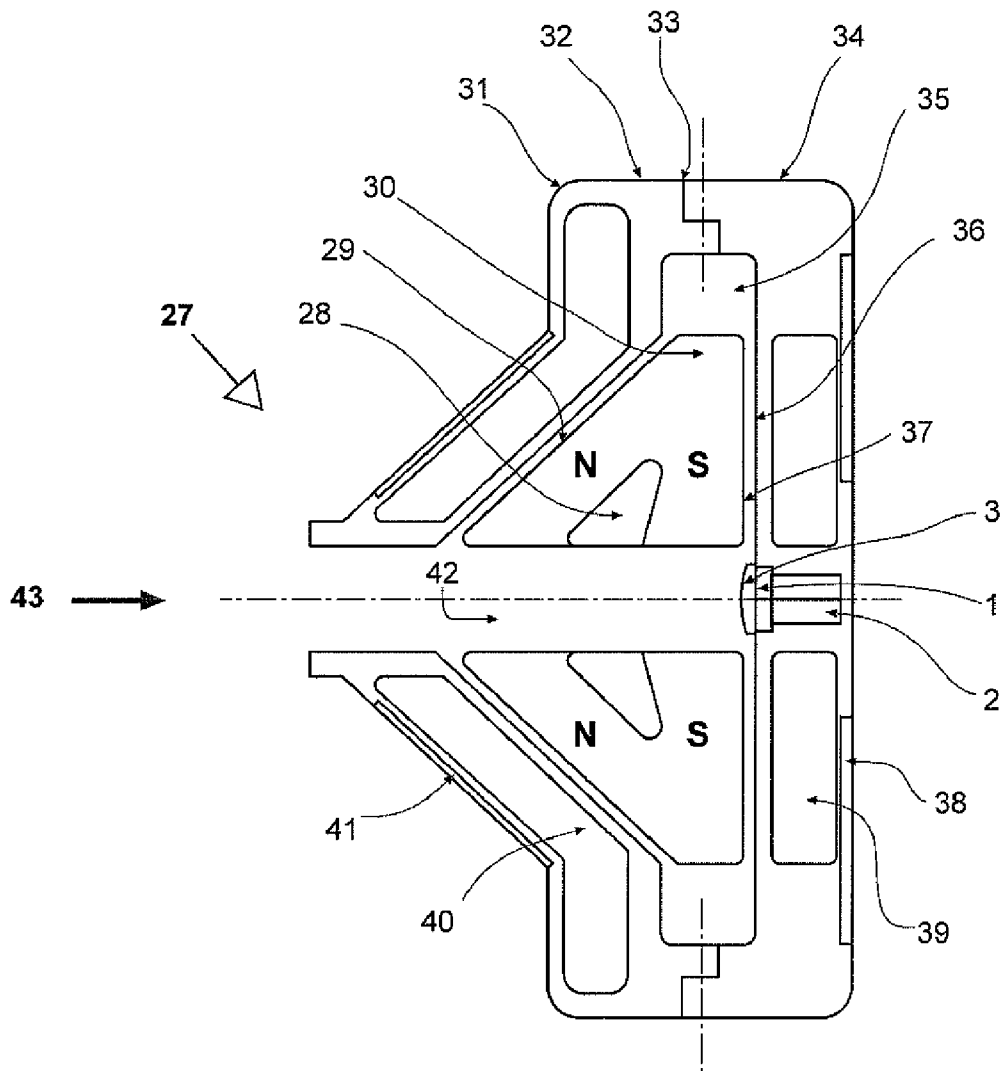

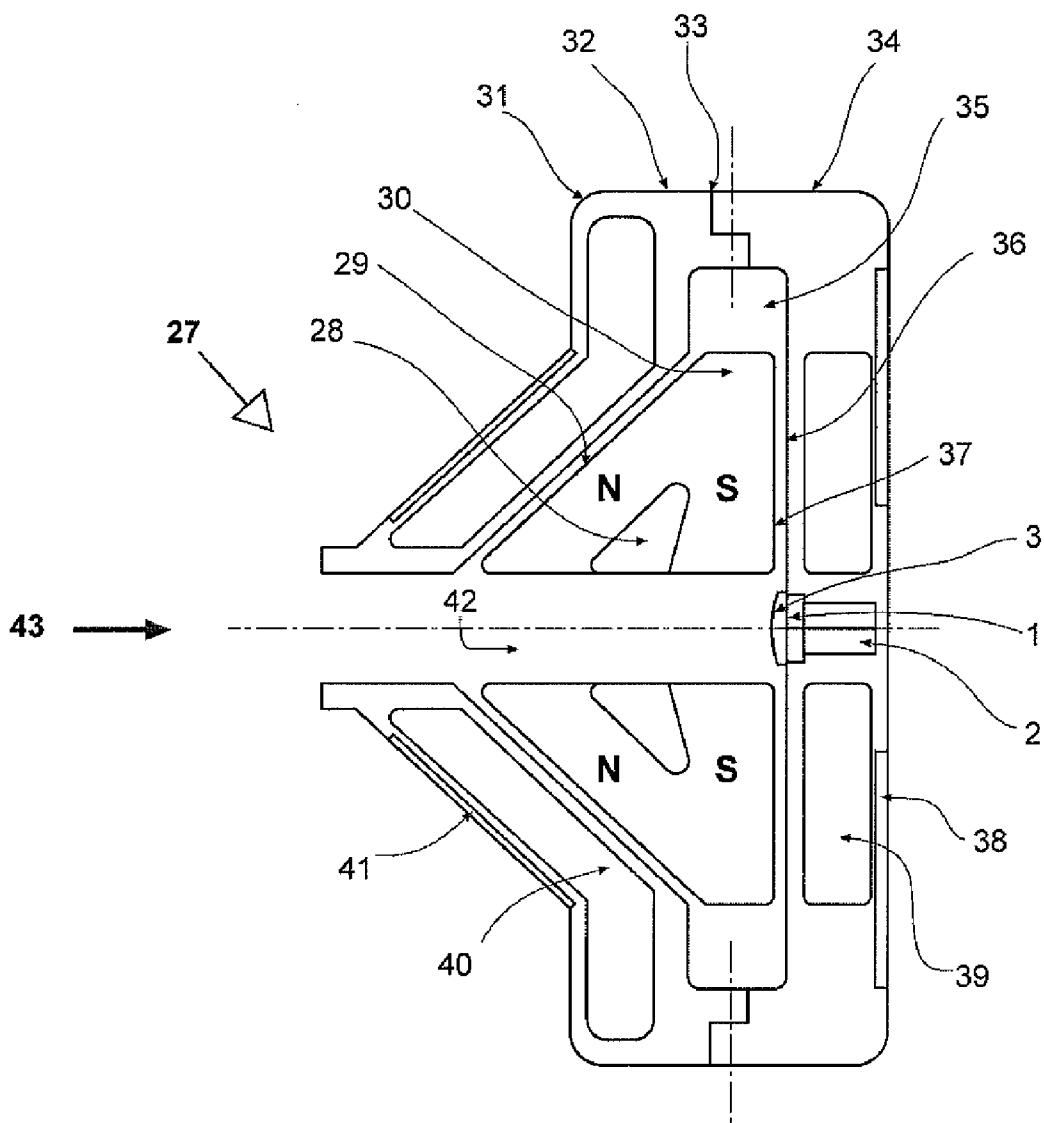

Fig. 1

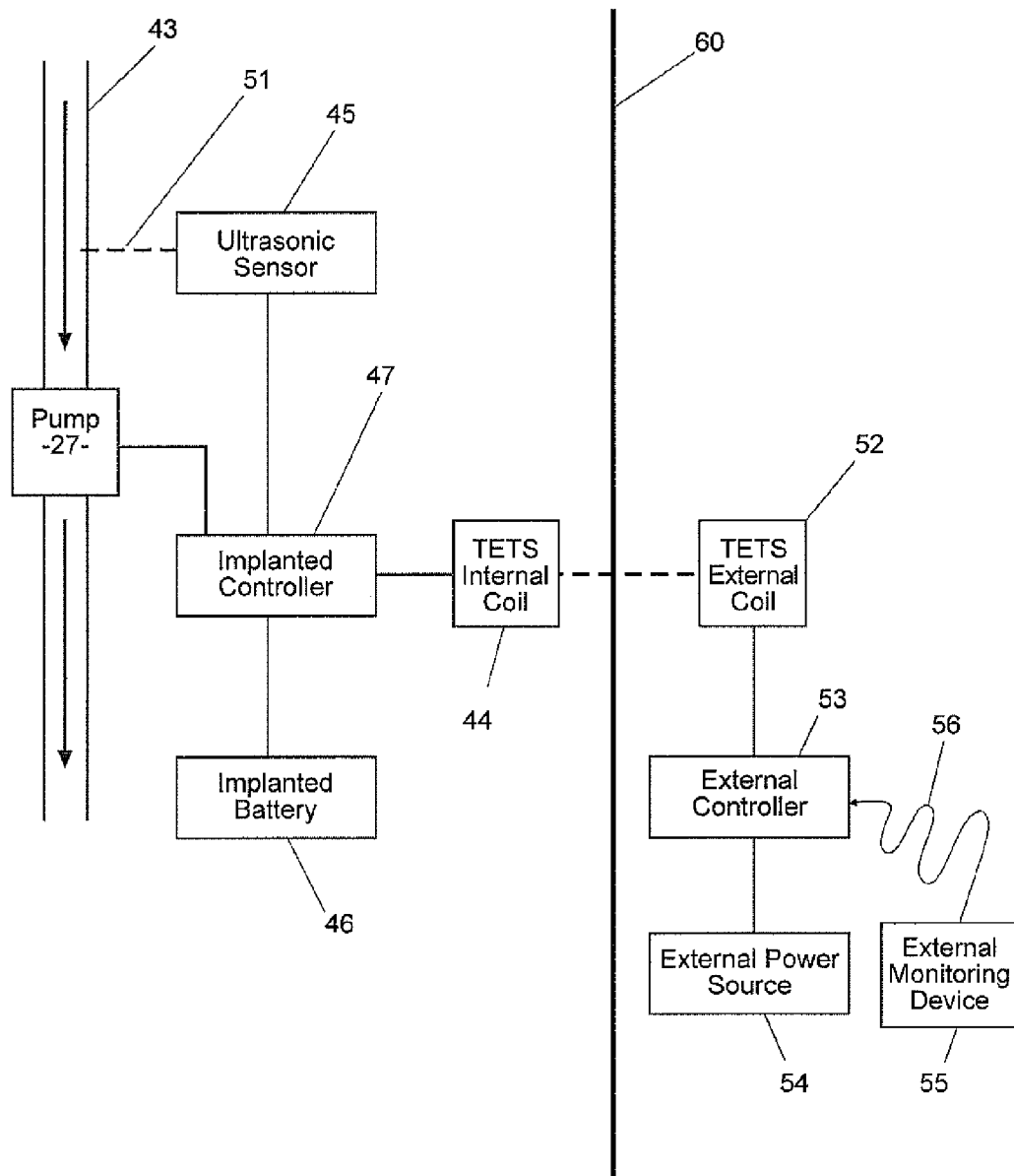

Fig. 2

BLOOD PUMP WITH AN ULTRASONIC TRANSDUCER

TECHNICAL FIELD

[0001] The present invention relates to an implantable blood pump with an ultrasonic transducer to detect and measure blood flow, and to enable ultrasound imaging.

BACKGROUND OF THE INVENTION

[0002] In the past, blood pumps have been used successfully to treat patients with late stage congestive heart disease or failure. Commonly, pulsatile blood pumps or continuous flow rotary blood pumps have been connected in parallel to a patient's heart to supplement or assist their heart in pumping blood through the patient's circulatory system. These types of blood pump are been commonly called left ventricular assist devices (LVADs) because they are generally connected between the left ventricle of the patients heart and the aorta to offload the heart.

[0003] A preferred example of an implantable rotary blood pump is described in U.S. Pat. No. 6,227,797 (Watterson et al). This pump is a continuous flow blood pump which includes a hydrodynamically suspended impeller that rotates to impart a centrifugal force on the blood in the pumping chamber. The blood is propelled to the rest of the circulatory system. The impeller described within this specification is generally shaft-less and this feature may significantly reduce the areas or regions stagnation for the blood travelling through the pump. U.S. Pat. No. 6,227,797 describes a blood pump suitable for implantation within the body of the patient.

[0004] The concept of an implantable ultrasonic sensor for detecting blood flow is detailed within U.S. Pat. No. 5,865,749 (Doten et al). This disclosure describes an implanted ultrasonic sensor that directly measures the blood flow within a patient's circulatory system by the attachment of the sensor onto a blood vessel.

[0005] U.S. Pat. No. 5,423,747 (Amano) describes an ultrasonic sensor and an extracorporeal blood pump being used simultaneously to inform a doctor or clinician of any problems or events experienced by a patient. These events may include significant reductions in blood flow from over-pumping the ventricle by the pump or clotting of the blood. When an event is detected, the doctor or clinician may immediately take action to remedy the problem by slowing the pumping speed set-point or stopping the blood pump. This arrangement has several significant disadvantages. The first disadvantage is that the arrangement requires the blood pump and ultrasonic sensor to be extracorporeal relative to the patient, which generally means the patient is bed ridden and restricted to a hospital environment. The second disadvantage is that the described ultrasonic sensor and blood pump are separate components and are not part of an integrated system. In addition, the arrangement described has a relatively large surface area of blood contacting regions which may increase the risk of thrombogenesis or clotting. The third problem is that the described system does not include an automatic control system using the measurements from the ultrasonic transducer to allow a pump controller to automatically adjust the pumping speed set-point of the blood pump without the doctor or clinician manually adjusting the speed, therefore the described system relies entirely on the doctor or clinician detecting a problem and taking immediate action to remedy said problem.

[0006] The present invention aims to or at least address or ameliorate one or more of the disadvantages associated with the above mentioned prior art.

SUMMARY OF THE INVENTION

[0007] According to a first aspect the present invention is a blood pump including a ultrasonic sensor mounted in or on a blood contacting surface of said blood pump, said ultrasonic sensor measures blood velocity and reports information to a blood pump controller and wherein said ultrasonic sensor is directed to measure blood velocity in an inflow cannula connected to the blood pump.

[0008] Preferably the ultrasonic sensor is mounted on a lower surface of the blood pump.

[0009] Preferably the blood pump is a rotary blood pump and includes a shaft-less rotary impeller.

[0010] Preferably said blood pump controller adjusts a pumping speed setpoint of the blood pump in accordance with the detected blood flow in the inflow cannula.

[0011] Preferably said blood pump is fully implanted within the body of the patient.

[0012] Preferably said blood pump controller is implanted within the patient and wirelessly transmits power and data with an external system.

[0013] Preferably the blood pump controller derives haematocrit values from the detected blood flow, actual speed of blood pump, and power consumed by blood pump.

[0014] Preferably the blood pump controller calculates the imminence of a collapse of the left ventricle or occlusion based the detected values of blood flow.

[0015] Preferably the blood pump controller pulses the pumping speed setpoint of the blood pump synchronously with the pulsing of blood flow detected in the inflow cannula.

[0016] According to a second aspect the present invention is a blood pump including at least one ultrasonic sensor mounted within a portion of the blood pump, wherein the sensor is aimed at the cavity of a ventricle and is capable of detecting or measuring motion of the either the aortic or mitral valves.

[0017] Preferably said ultrasonic sensor is connected to a pump controller, which maintains the pumping speed of said pump, and wherein pump controller adjusts pumping state in accordance the detected motion of the aortic or mitral valves.

[0018] According to a third aspect the present invention is a pump including at least one ultrasonic sensor mounted within a portion of the blood pump, wherein the sensor measures blood flow and a pump controller, which is connected to the sensor and pump, calculates haematocrit based on measured flow.

BRIEF DESCRIPTION OF THE DRAWINGS

[0019] Embodiments of the present invention will now be described with reference to the accompanying drawings wherein:

[0020] FIG. 1 depicts a cross sectional view of a first embodiment of the present invention; and

[0021] FIG. 2 depicts a schematic view of the first embodiment when implanted within a patient.

BRIEF DESCRIPTION OF THE PREFERRED EMBODIMENTS

[0022] A first preferred embodiment of the present invention is depicted in FIGS. 1 & 2. In this first preferred embodiment, a blood pump 27 includes an impeller 30 mounted within a cavity 37 within a housing 32.

[0023] The most preferred blood pump for use with this first preferred embodiment is

similar to the blood pump described within U.S. Pat. No. 6,227,797 (Watterson et al). When in use, impeller **30** is magnetically urged to rotate by upper and lower stator coil assemblies **40** & **39** acting on permanent rare earth magnets **28** embedded within each blade of the impeller **30**.

[0024] When in operation, impeller **30** is hydrodynamically suspended by thrust forces generated by tapered edges of the blades forming a “restriction area” as the blades rotate. The “restriction area” forms in a region of relatively high pressure in gaps **29** & **36** and this pressure forces impeller **30** away from housing **32** at an angle normal relative to the angle of the inner housing surface.

[0025] Furthermore, the preferred impeller **30** is shaft-less, see central region **42**, minimizing regions of stagnation that are commonly associated with regions of low flow such as shafts or mechanical pivot bearings. Preferably, impeller **30** includes four generally “shark fin” shaped blades which are generally positioned in a circular arrangement by interconnecting struts.

[0026] Blood pump **27** operates by magnetically rotating impeller **30** about an axis of rotation in housing **32**. The motion of the rotating blades imparts a centrifugal force on blood entering pump **27** via inflow cannula **43**. The centrifugal force displaces the blood outwardly from the centre of pump **27** to the outer wall of housing **32**. The outer wall generally includes an outlet, which is in turn connected to an outflow cannula **35**.

[0027] Preferably, blood pump **27** is fully or wholly implanted within the body of a patient. Inflow cannula **43** is connected to the left ventricle of the heart through a hole cored by a surgeon into the apex of the left ventricle (not shown). Outflow cannula **35** is generally connected to the patients aorta by suturing (not shown). The net result is that blood pump **27** acts in parallel to the normal pumping function of the heart and assists the left ventricle.

[0028] Upper and lower stator coil assemblies **40**, **39** are mounted on opposed sides of impeller **30** in the housing **32**. The stator coil assemblies **39** & **40** generally comprise phase coils constructed of electrically conductive wire capable of inducing electromagnetism when a current is applied. Preferably, there are three phase coils mounted on the upper and lower portions of housing. The electromagnetic efficiency of the coil assemblies may be increased by the further mounting of yokes **41** & **38** on the outside of the stator coil assemblies.

[0029] Preferably, housing **32** includes upper and lower portions **31**, **34** joined hermetically by seal **33**. The seal **33** is preferably achieved by laser welding of the housing portions which are preferably made of Titanium alloy.

[0030] An ultrasonic transducer **1** may be mounted in the centre of the base plate located on the inner wall of the lower portion **34** of housing **32**. Mounting the ultrasonic transducer **1** within blood pump **27** significantly reduces the area of blood contacting surface used by this arrangement, when compared to having a prior art arrangement where the blood pump and ultrasonic transducer are separately implanted components or items. Preferably, the ultrasonic transducer **1** is mounted behind a relatively thin titanium wall in the hermetically sealed space within housing **32**. As will be apparent to a person skilled in the art, an ultrasound coupling lens **2** is used to couple the ultrasound energy from the transducer **1** to the titanium base-plate, and if necessary an ultrasound lens **3** is used to focus and direct the ultrasound beam such that the ultrasound beam is directed up along the axis of rotation of impeller **30** and insonates the incoming blood in the inflow cannula. In this embodiment, this is achieved because the

impeller **30** is shaft-less and the ultrasonic transducer **1** has an uninterrupted view (or path) into the inflow cannula **35** from the aforementioned base plate.

[0031] In an alternative embodiment, the ultrasound transducer and coupling means may be mounted inside the blood pump and contacting the blood directly. This is possible in the earlier described blood pump **30** because impeller **30** is shaft-less, and therefore the ultrasound transducer if mounted inside the blood filled chamber of pump **27**, does not occlude the flow or inhibit free movement of impeller **30**.

[0032] The ultrasound coupling lenses, dimensions, frequency, and power of the ultrasound system is determined by the distances needed to be insonated. Such determination is easily done by someone skilled in the art and is dependent on the overall dimensions of blood pump **27**.

[0033] Since the ultrasound signal is at a different frequency to the signal used to energize the motor, it may be able to capacitively and/or inductively couple the ultrasound signals to the phase wires within the stator assemblies **39** & **40**, thus obviating the need for additional wires to pump **27**. Alternatively, the ultrasound electronics may be included in the hermetically sealed housing **32** of pump **27**, obtain energy from the phase wires used to energize the motor, and wirelessly communicate with the outside world via the use of radio frequency communications or other standard wireless interfaces (eg. Bluetooth™ technology).

[0034] In an alternative embodiment, blood pump **27** may include a phased array ultrasound transducer system which would allow direct imaging through housing **32** of blood flowing into pump **27** and the system components, even up to the left ventricular cavity.

[0035] Preferably, an ultrasound pulse may be transmitted by the ultrasonic transducer

at predetermined time intervals along the axis of rotation of the shaft-less impeller **30**. The reflected ultrasonic echoes may be used to determine:

- a) the velocity of the blood at different points along the axis of the impeller by the use of standard ultrasound Doppler technology, including all the way up the inlet cannula **43** and into the left ventricle;
- b) real-time movement and function of the left ventricle wall; and, depending on location of pump **27** and inlet cannula **43**, the leaflets of the mitral and/or aortic valves (this is commonly referred to as M-mode ultrasound);
- c) using spectral analysis of the returned ultrasonic echoes, the solid matter content of the blood, which is related directly to hematocrit; and/or
- d) if an array system is used, an image of the blood path all the way up to the left ventricle and valves.

[0036] These data may be used as input parameters to a control system, and in particular may be used to:

- a) directly measure flow velocity and, by knowing the cross sectional area of the inflow cannula, therefore calculate volume blood flow eg: in liters per minute;
- b) from flow, speed and power, derive hematocrit from the pump head pressure vs flow relationships (commonly referred to as H-Q curves);
- c) use the spectral characteristics of the ultrasonic echoes to also determine hematocrit, and thereby provide a cross check (mutual recalibration);
- d) directly determine presence or incipience of ventricular suction by measuring flow and/or determining movements of the left ventricular free wall;
- e) detect occlusion of the inflow cannula **43**;
- f) determine a difference between measured flow and derived flow (from the H-Q curves) and thereby determine when the pump may be occluded; and/or

g) used to control pulsatility of flow by synchronizing pump speed changes with movement of the LV wall and/or changes in blood velocity.

[0037] Further, FIG. 2 depicts the first preferred embodiment implanted within a patient. Blood pump 27, as per FIG. 1, is connected to the circulatory system of the patient by an inflow cannula 43 and outflow cannula 35. Pump 27 is controlled by implanted controller 47, which sets an optimal pumping speed set-point for pump 27 and regulates its speed at the set-point. The implanted controller 47 is preferably connected to ultrasonic transducer 1 which is within the housing of the pump, but for schematic simplicity is shown as a separate component. Preferably, implanted controller 47 receives data from ultrasonic transducer 1 and uses these data to detect an actual measured blood flow in the inflow cannula 43. From these data, implanted controller 47 may be able to derive suction events, hematocrit levels, occlusion, or the general motion of the left ventricle.

[0038] Preferably, implanted controller 47, pump 27 and transducer 1 are powered by a rechargeable implanted battery 46. All of the implanted components of this system are implanted below the skin layer 60 of a patient. The implanted components of the system are powered by and communicate data with the external environment using a transcutaneous energy transmission system (commonly referred to as 'TETS'). TETS includes an implanted coil 44 of wire and an external coil 52 of wire mounted in a parallel orientation on either side of the skin layer in close proximity. When a current is induced in one coil, the other coil also experiences an inducement to create a current. Using the TETS, it is possible to transmit power and data across the skin layer of the patient without the need for a permanent wound created by percutaneous lead arrangements. Using the TETS, the system also includes an external system comprising an external controller 53 and external power source 54. The external power source 54 may be another battery pack or a connection to mains power. The external controller 53 may function as a backup system for the implanted controller 47 and may also be capable of retrieving and interrogating data from the implanted controller 47 and transmitting to other systems such as other computers, and the internet.

[0039] When a patient presents for follow up, it is desirable for the attending physician or other health care professional to monitor current and historical performance of the LVAD system. This may be performed using a monitoring device eg. laptop computer 55, which communicates with external controller 53 via a link 56 (by physical cable or wireless technology). In one embodiment, the communication between the controller 53 and the laptop computer 55 could be over a long distance such as via the internet.

[0040] During the monitoring process, the external monitoring means 55 obtains data from the implantable controller and ultrasound system via the external controller (or directly). These data might include historical records of blood velocity and flow, haematocrit, alarm conditions and the like. The data may also include real time information about blood velocity and flow, and if the ultrasound system includes the capacity to create an image, then that image would be displayed on the external monitoring means.

[0041] Additionally, ultrasonic transducer 1 may be preferably aimed at the cavity within the right or left ventricles of the patient's heart. If the ultrasonic transducer 1 is angled and orientated properly, the transducer 1 may be able to visualise the blood flow within the ventricle. More specifically, it may

be possible to adjust the orientation of the sensor to visualise, detect or measure the opening and closing of either the aortic or mitral valves (in the case of the left ventricle). The detection of this motion of the valves may be then feedback into the control system which is managing the pumping speed of the bloodpump. Preferably, the control system may adjust the pumping speed of the blood pump so to allow the valves of the heart to function normally by opening and closing thus reducing the incidence of thrombogenesis occurring around the valves.

[0042] The above description, detail only some of the embodiments of the present invention. Modifications may be obvious to those skilled in the art and may be made without departing from the scope and spirit of the present invention.

1. A blood pump including a ultrasonic sensor mounted in or on a blood contacting surface of said blood pump, said ultrasonic sensor measures blood velocity and reports information to a blood pump controller and wherein said ultrasonic sensor is directed to measure blood velocity in an inflow cannula connected to the blood pump.

2. The blood pump of claim 1, wherein the ultrasonic sensor is mounted on a lower surface of the blood pump.

2. The blood pump of claim 2, wherein the blood pump is a rotary blood pump and includes a shaft-less rotary impeller.

3. The blood pump of claim 3, wherein said blood pump controller adjusts a pumping speed setpoint of the blood pump in accordance with the detected blood flow in the inflow cannula

4. The blood pump of claim 4, wherein the blood pump is fully implanted within the body of the patient.

5. The blood pump of claim 5, wherein said blood pump controller is implanted within the patient and wirelessly transmits power and data with an external system.

7. The blood pump of claim 1, wherein the blood pump controller derives haematocrit values from the detected blood flow, actual speed of blood pump, and power consumed by blood pump.

8. The blood pump of claim 1, wherein the blood pump controller calculates the imminence of a collapse of the left ventricle or occlusion based the detected values of blood flow.

9. The blood pump of claim 2, wherein the blood pump controller pulses the pumping speed setpoint of the blood pump synchronously with the pulsing of blood flow detected in the inflow cannula

10. A blood pump including at least one ultrasonic sensor mounted within a portion of the blood pump, wherein the sensor is aimed at the cavity of a ventricle and is capable of detecting or measuring motion of the either the aortic or mitral valves.

11. The blood pump of claim 10, wherein said ultrasonic sensor is connected to a pump controller, which maintains the pumping speed of said pump, and wherein pump controller adjusts pumping state in accordance the detected motion of the aortic or mitral valves.

12. A blood pump including at least one ultrasonic sensor mounted within a portion of the blood pump, wherein the sensor measures blood flow and a pump controller, which is connected to the sensor and pump, calculates haematocrit based on measured flow.

* * * * *