

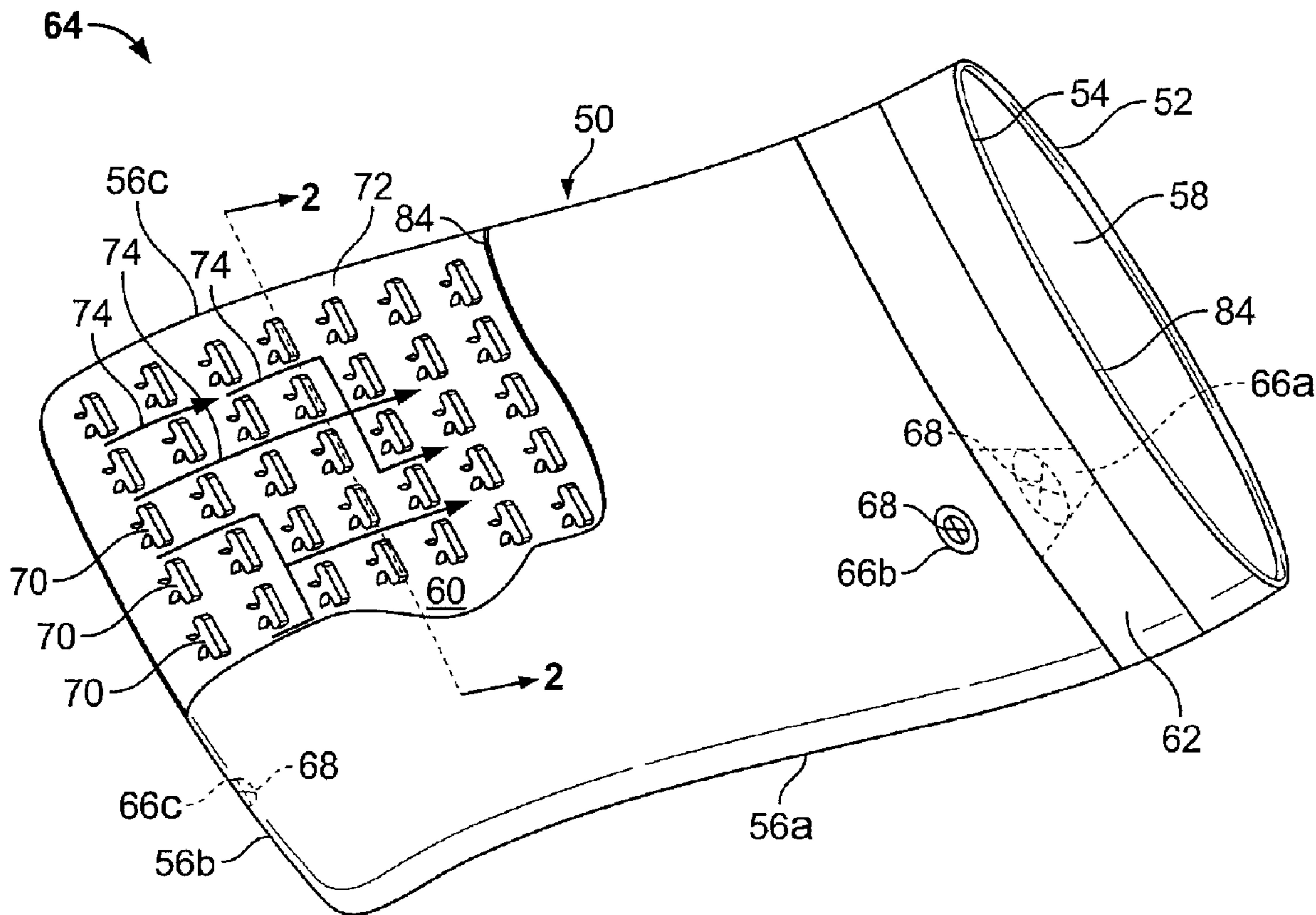

(22) Date de dépôt/Filing Date: 2008/06/13
 (41) Mise à la disp. pub./Open to Public Insp.: 2008/12/15
 (45) Date de délivrance/Issue Date: 2013/05/14
 (62) Demande originale/Original Application: 2 635 091
 (30) Priorité/Priority: 2007/06/15 (US11/818,584)

(51) Cl.Int./Int.Cl. *B65D 33/36* (2006.01),
B65D 30/10 (2006.01), *B65D 33/01* (2006.01),
B65D 81/20 (2006.01)
 (72) Inventeurs/Inventors:
 TURVEY, ROBERT R., US;
 DAIS, BRIAN C., US;
 ZIMMERMAN, DANIEL P., US;
 GRIFFIOEN, KELLY M., US
 (73) Propriétaire/Owner:
 S.C. JOHNSON HOME STORAGE, INC., US
 (74) Agent: BERESKIN & PARR LLP/S.E.N.C.R.L.,S.R.L.

(54) Titre : CANAUX D'ECOULEMENT POUR SAC
 (54) Title: FLOW CHANNELS FOR A POUCH



(57) Abrégé/Abstract:

A pouch includes first and second pouch walls that define an interior of the pouch, and an opening to the interior of the pouch is provided in at least one of the first and second pouch walls. A flow channel profile is disposed on an inner surface of the first pouch



(57) **Abrégé(suite)/Abstract(continued):**

wall, and a complementary groove is disposed on an inner surface of the second pouch wall. The complementary groove releasably engages the flow channel profile so as to define a flow channel between the first and second pouch walls. The flow channel profile extends between the opening and a portion of an interior of the pouch that is spaced from the opening. When the flow channel profile is releasably engaged with the complementary groove, a tip of the flow channel profile contacts a surface the complementary groove, and a surface of the flow channel profile that is adjacent to the tip also contacts a surface of the complementary groove.

FLOW CHANNELS FOR A POUCH

ABSTRACT OF THE DISCLOSURE

A pouch includes first and second pouch walls that define an interior of the pouch, and an opening to the interior of the pouch is provided in at least one of the first and second pouch walls. A flow channel profile is disposed on an inner surface of the first pouch wall, and a complementary groove is disposed on an inner surface of the second pouch wall. The complementary groove releasably engages the flow channel profile so as to define a flow channel between the first and second pouch walls. The flow channel profile extends between the opening and a portion of an interior of the pouch that is spaced from the opening. When the flow channel profile is releasably engaged with the complementary groove, a tip of the flow channel profile contacts a surface the complementary groove, and a surface of the flow channel profile that is adjacent to the tip also contacts a surface of the complementary groove.

-1-

TITLE

FLOW CHANNELS FOR A POUCH

CROSS REFERENCE TO RELATED APPLICATIONS

[0001] Not applicable

REFERENCE REGARDING FEDERALLY SPONSORED RESEARCH OR
DEVELOPMENT

[0002] Not applicable

SEQUENTIAL LISTING

[0003] Not applicable

BACKGROUND OF THE INVENTION

1. Field of the Invention

[0004] The present invention relates generally to pouches, and particularly to a flow channel that may be used to evacuate a pouch.

2. Description of the Background of the Invention

[0005] Pouches are typically used for storage and preservation of perishable contents such as food. Perishable contents may be made to last longer with less degradation if stored under vacuum. Evacuatable thermoplastic pouches have been designed to work with a vacuum source to allow storage of contents under vacuum. However, a problem with evacuating a thermoplastic pouch is that the pouch has flexible walls that are forced together into contact with one another as a result of the evacuation. Regions of the pouch interior may thus be blocked from the vacuum source by the contacting walls, making those regions difficult or

-2-

impossible to evacuate. In response to this problem, evacuable thermoplastic pouches have been designed with various flow channels that function to prevent the pouch walls from coming into contact and blocking off regions of the pouch from the vacuum source.

[0006] One such pouch has a thick textured porous sheet that is affixed to an inner surface of a pouch wall over an aperture in the pouch wall. The sheet has dimensions similar to the pouch wall and functions to prevent the pouch walls from adhering to one another during evacuation. The sheet provides flow paths from the pouch interior to the aperture to prevent the pouch walls from adhering, thus preventing evacuation of the pouch. Another pouch has a strip of mesh or woven material that extends from the pouch interior to a mouth of the pouch. The strip of mesh may be inserted by a user or affixed to the pouch interior during manufacture. The strip may alternatively be comprised of a plurality of tubes held together to form the strip.

[0007] A further pouch has a strip of flexible plastic material attached to an interior of the pouch. The pouch has an aperture that extends through a wall of the pouch proximate an end of the pouch. The strip has a flat base and a plurality of ribs disposed lengthwise on one side of the base. A first end of the strip is attached to the interior of the pouch opposite the aperture. A second end of the strip is attached to a region of the interior that is at an opposite end of the pouch from the aperture. The ribs provide fluid communication between the aperture and the entire length of the strip.

[0008] Other pouches have protuberances that are extruded integrally with a sidewall or embossed onto a sidewall of the pouch between an interior of the pouch and an evacuation aperture. Each protuberance has a body that extends away from the sidewall between a base end and a distal end. The body has parallel side walls or is generally tapered from the base end to the smaller distal end. The protuberances may take the form of discrete shapes or may be joined to form ridges. The protuberances may also be arranged irregularly or formed into patterns. Channels formed between the protuberances provide fluid communication between the evacuation aperture and the interior of the pouch.

[0009] Yet another pouch has one or more wall panels that are formed from a material that is pressed between rollers to impart a corrugated cross-section to the material. Grooves

-3-

and ridges formed by the rollers are imparted on an angle with respect to the direction of forming. The material is folded upon itself to form the pouch with the wall panels, wherein the pouch has grooves and ridges in each wall panel that intersect with grooves and ridges on an opposing wall panel. The intersecting grooves and ridges prevent the wall material from flattening under evacuation, thereby creating air channels throughout the pouch.

[0010] Still another pouch has a pattern of channels on a sidewall that is created by pressing a melt-extruded resin between rollers. The channels have baffles that allow gases to escape from the pouch, yet trap liquid within the pouch. Another pouch has at least one sidewall that has a zigzag pattern of channels or ridges formed therein or thereon, respectively.

[0011] Pouches that have flow channels may have regions of the pouch interior blocked from a vacuum source by an opposing sidewall that has entirely collapsed into a channel due to the inherent flexibility of the opposing sidewall material. Narrower flow channels can lessen blockage caused by the collapsed opposite sidewall, but also have decreased flow volume. Sidewalls made of more rigid material can also lessen blockage by limiting collapse, but necessarily have less flexibility.

SUMMARY OF THE INVENTION

[0012] According to one aspect of the invention a pouch comprising: first and second pouch walls, the first and second pouch walls defining an interior of the pouch, and an opening to the interior of the pouch being provided in at least one of the first and second pouch walls; a flow channel profile disposed on an inner surface of the first pouch wall; and a complementary groove disposed on an inner surface of the second pouch wall, the complementary groove being configured to releasably engage with the flow channel profile so as to define a flow channel between the first and second pouch walls, wherein the flow channel profile extends between the opening and a portion of an interior of the pouch that is spaced from the opening, and wherein, when the flow channel profile is releasably engaged with the complementary groove, a tip of the flow channel profile contacts a surface of the complementary groove, and a surface of the flow channel profile that is adjacent to the tip also contacts a surface of the complementary groove.

[0013] Deleted

[0014] Deleted

BRIEF DESCRIPTION OF THE DRAWINGS

[0015] FIG. 1 is an isometric partial cutaway view of a pouch illustrating a plurality of flow channel protuberances extending from an inner surface of a first pouch wall;

[0016] FIG. 2 is a fragmentary cross-sectional view of a first embodiment of flow channels taken generally along the lines 2-2 of FIG. 1 with portions behind the plane of the cross-section omitted for clarity;

[0017] FIG. 3 is a fragmentary cross-sectional view illustrating other embodiments of flow channels taken generally along the lines 2-2 of FIG. 1 with portions behind the plane of the cross-section omitted for clarity;

[0018] FIG. 4 is an isometric partial cutaway view of a pouch illustrating a further embodiment of flow channels;

[0019] FIG. 5 is a fragmentary cross-sectional view taken generally along the lines 5-5 of FIG. 4 with portions behind the plane of the cross-section omitted for clarity;

[0020] FIG. 6 is a plan view of yet another embodiment of flow channels illustrating segmented flow channel profiles;

-5-

[0021] FIG. 7 is an isometric partial cutaway view illustrating a still further embodiment of flow channels;

[0022] FIG. 8 is a fragmentary cross-sectional view similar to the views of FIGS. 2, 3, and 5, and illustrating still further embodiments of flow channels; and

[0023] Fig. 9 is a cross-sectional view similar to the views of FIGS. 2, 3, 5, and 8, and illustrating still other embodiments of flow channels.

[0024] Other aspects and advantages of the present invention will become apparent upon consideration of the following detailed description, wherein similar structures have similar reference numerals.

DETAILED DESCRIPTION

[0025] Referring to FIG. 1, a reclosable pouch 50 has a first sidewall 52 and a second sidewall 54. Illustratively, the first and second sidewalls 52, 54 may be made of one or more thermoplastic materials or resins such as polyolefin, including, for example, polyethylene and polypropylene. The first and second sidewalls 52, 54 are joined at three edges 56a-56c by heat sealing or any other sealing method known in the art to define a mouth 58 leading to an interior 60. The edge 56b may also be a fold line separating a single piece of material into the first and second sidewalls 52 and 54. The first sidewall 52 includes an inner surface 72 and the second sidewall 54 includes an inner surface 84.

[0026] A closure mechanism 62 extends across the pouch 50 proximate the mouth 58. The closure mechanism 62 allows the pouch 50 to be repeatedly opened and closed. When occluded, the closure mechanism 62 provides an airtight seal such that a vacuum may be maintained in the pouch interior 60 for a desired period of time, such as days, months, or years, when the closure mechanism is sealed fully across the mouth 58. The closure mechanism 62 comprises first and second closure elements (not shown) that are attached respectively to the inner surfaces 72 and 84 of the first and second sidewalls 52 and 54. The first closure element includes one or more interlocking closure profiles (not shown), and the second closure element also includes one or more interlocking closure profiles (not shown).

The first and second interlocking closure profiles may be male and female closure profiles, respectively. However, the configuration and geometry of the, interlocking profiles or closure elements disclosed herein may vary.

[0027] In a further embodiment, one or both of the first and second closure elements (not shown) may include one or more textured portions, such as a bump or crosswise groove in one or more of the first and second closure profiles in order to provide a tactile sensation, such as a series of clicks, as a user draws the fingers along the closure mechanism 62 to seal the closure elements across the mouth 58. In another embodiment, the first and second interlocking closure profiles (not shown) include textured portions along the length of each profile to provide tactile and/or audible sensations when closing the closure mechanism 62. In addition, protuberances, for example ridges (not shown), may be disposed on the inner surfaces 72, 84 of the respective first and second sidewalls 52, 54 proximate the mouth 58 to provide increased traction in a convenient area for a user to grip, such as a gripping flange, when trying to open the sealed pouch 50. Further, in some embodiments, a sealing material such as a polyolefin material or a caulking composition such as silicone grease may be disposed on or in the interlocking profiles or closure elements to fill in any gaps or spaces therein when occluded. The ends of the interlocking profiles or closure elements may also be welded or sealed by ultrasonic vibrations as is known in the art. Illustrative interlocking profiles, closure elements, sealing materials, tactile or audible closure elements, and/or end seals useful in the present invention include those disclosed in, for example, Pawloski U.S. Patent No. 4,927,474, Dais et al. U.S. Patent Nos. 5,070,584, 5,478,228, and 6,021,557, Tomic et al. U.S. Patent No. 5,655,273, Sprehe U.S. Patent No. 6,954,969, Kasai et al. U.S. Patent No. 5,689,866, Ausnit U.S. Patent No. 6,185,796, Wright et al. U.S. Patent No. 7,041,249, Pawloski et al. U.S. Patent No. 7,137,736, Anderson U.S. Patent Application Publication No. 2004/0091179, Pawloski U.S. Patent Application Publication No. 2004/0234172, Tilman et al. U.S. Patent Application Publication No. 2006/0048483, and Anzini et al. U.S. Patent Application Publication Nos. 2006/0093242 and 2006/0111226. Other interlocking profiles and closure elements useful in the present invention include those disclosed in, for example, U.S. Patent 7,886,412, and Canadian patent applications 2,635,090; 2,635,086; and 2,635,092.

It is further appreciated that the interlocking profiles or closure elements disclosed herein may be operated by hand, or a slider (not shown) may be used to assist in occluding and de-occluding the interlocking profiles and closure elements.

[0028] An exterior 64 of the pouch 50 is also shown in FIG. 1. An opening 66a, 66b, or 66c allows fluid communication between the interior 60 and the exterior 64 of the pouch 50. The opening 66a may extend through or around the closure mechanism 62. Alternatively, the opening 66b may extend through either the first or second sidewall 52, 54. The opening 66c may also extend through a side edge 56a-56c, for example, through the bottom edge 56b. A valve 68 may optionally be disposed in or cover the opening 66a-66c to allow air to be evacuated from the pouch interior 60 and to maintain a vacuum when the closure mechanism 62 has been sealed. As shown in FIG. 1, the valve 68 may be disposed on the second sidewall 54 spaced from the closure mechanism 62. The valve 68 provides a fluid path with fluid communication between the pouch interior 60 and the exterior 64 of the pouch. Illustrative valves useful in the present invention include those disclosed in, for example, Newrones et al. U.S. Patent application publication No. 2006/0228057. Other valves useful in the present invention include those disclosed in, for example, Canadian patent applications 2,635,094; 2,635,092; and 2,634,886.

[0029] Although not shown, in some embodiments an evacuation pump or device may be used to evacuate fluid from the pouch 50 through, for example, the valve 68 disposed in one of the sidewalls 52, 54, or in the closure mechanism 62 or one of the side edges 56a-56c of the pouch. Illustrative evacuation pumps or devices useful in the present invention include those disclosed in, for example, Canadian patent application 2,635,095.

[0030] In a first embodiment shown in FIGS. 1 and 2, a plurality of flow channel protuberances 70 are arranged regularly or irregularly on the inner surface 72 of the first sidewall 52. The protuberances 70 define flow channels 74 between the first and second sidewalls 52, 54 as depicted, for example, by the lines and arrows in FIGS. 1 and 2, and that

extend from the interior 60 to the opening 66a-66c of the pouch 50. Illustratively, the flow channel 74 provides fluid communication between the opening 66a-66c and a portion of the interior 60 that is spaced from the opening 66a-66c. For example, an embodiment including the opening 66b that extends through a first sidewall 52 includes a flow channel 74 that extends from directly opposite the opening to a portion of the interior 60 that is spaced from the opening. Alternatively, embodiments including either of the openings 66a or 66c include a flow channel 74 that extends from directly adjacent the opening to a portion of the interior 60 that is spaced from the opening. The flow channels 74 defined by the protuberances 70 may be straight or curved. The flow channels 74 defined by the protuberances 70 may be parallel to one another, or in other embodiments not shown, may extend radially away from the opening 66a-66c in, for example, an expanding sunburst configuration, or may have any other configuration such that the flow channels 74 provide fluid communication between the opening 66a-66c and a portion of the pouch interior 60 spaced from the opening when the pouch 50 is under vacuum pressure.

[0031] Referring to FIG. 2, the protuberances 70 may be integral with the first sidewall 52. Each of the protuberances 70 includes a first component 76 that extends from the first sidewall 52. Each protuberance 70 also includes a second component 78 that extends laterally away from the first component 76 proximate a distal end 80 thereof. The second component 78 may be round or square or any convenient shape and may extend laterally away from the first component 76 at any non-zero angle with respect to the first component 76 around a part or an entire periphery thereof. The second component 78 provides increased surface area 82 on a distal end 90 of each protuberance 70.

[0032] Further, a solid material that includes fixed or supported portions is displaced at an unsupported portion in response to a force applied to the unsupported portion. The amount of displacement depends upon, for example, the span of the unsupported portion, the amount and distribution of force applied thereto, and/or a material property of the solid material called the flex modulus. For example, in the pouch 50 being evacuated, unsupported portions of each of the first and second sidewalls 52, 54 may sag into the flow channel 74 by an amount that depends upon spacing between respective ends of the protuberances 70, the flex modulus for the material in each of the first and second sidewalls, and/or the level of

vacuum drawn on the pouch. Assuming a given composition for the first and second sidewalls 52, 54, and a given level of vacuum drawn on the pouch, the amount of sag of each of the first and second sidewalls therefore depends on the spacing between respective ends of the protuberances 70. The increased surface area 82 makes contact over an increased area of the inner surface 84 of the second sidewall 54, thereby leaving less of the second sidewall 54 disposed over the flow channel 74 unsupported during evacuation of the pouch 50. Inhibiting sag of the first and second sidewalls 52, 54 into the flow channels 74 allows the flow channels to remain open for a longer period of time while fluid is being evacuated therefrom and from the pouch.

[0033] Referring next to FIG. 3, the second component 78 of each flow channel protuberance 70 may also extend from an intermediate region 86 that may be at any position on the first component 76 between a base end 88 and the distal end 80 thereof. The second component 78 may again be any convenient shape and may extend laterally away from the first component 76 at any non-zero angle with respect to the first component 76 around a part or the entire periphery thereof. The second component 78 extends from the intermediate region 86 to increase the effective surface area 92 at the distal end 90 of the protuberance 70. Similar to the above, increased surface area 92 in contact with the inner surface 84 of the second sidewall 54 leaves less of the second sidewall 54 unsupported during evacuation of the pouch 50.

[0034] The flow channel protuberances 70 may also depend from a first side 94 of a base member 96, as illustrated in FIG. 3. A second side 98 of the base member 96 is affixed to the inner surface 72 of the first sidewall 52. The base member 96 may be affixed to the first sidewall 52 by a thermoplastic weld layer 210, a heat seal, an adhesive, or any other method known in the art. In each of the embodiments included herein, the flow channel protuberances 70 or profiles 100 (shown in FIGS. 4-9) may either be integral with the first sidewall 52 as described with respect to FIG. 2, or may depend from the first side 94 of the base member 96 as described with respect to FIG. 3. The flow channel protuberances 70 or profiles 100 may be extruded integrally with the base member 96 to form a three dimensional tape structure that may be fastened to the inner surfaces 72, 84 of the respective first and second sidewalls 52, 54 of the pouch 50 to create the flow channels 74.

-10-

[0035] Referring next to FIGS. 4 and 5, in a further embodiment, flow channel profiles 100 define flow channels 74 between the first and second sidewalls 52, 54 as depicted, for example, by the lines and arrows in FIG. 4, and that extend from the interior 60 to the opening 66a-66c of the pouch 50. Grooves 102 are provided on the inner surface 84 of the second sidewall 54. The grooves 102 align and engage with the flow channel profiles 100 when the pouch 50 is brought under vacuum pressure. The engaged profiles and grooves 100, 102 may reduce or limit lateral displacement of the second sidewall 54 across the profiles 100. The engaged profiles and grooves 100, 102 may also reduce or limit bowing of the profiles 100 in response to vacuum pressure. Therefore, the engaged profiles and grooves 100, 102 may provide increased effective structural rigidity for sections of the second sidewall 54 between the grooves 102. The engaged profiles and grooves 100, 102 therefore may lessen blockage of the flow channels 74 by limiting collapse of the second sidewall 54 during evacuation of the pouch 50. The flow channel profiles 100 of this embodiment may also be integral with the first sidewall 52 as disclosed in detail above with respect to FIG. 2, or may depend from the base member 96 that is affixed to the inner surface 72 of the first sidewall 52, as disclosed in detail above with respect to FIG. 3.

[0036] Referring now to FIG. 6, the flow channel profiles 100 may also be cut into segments 104. The segmented flow channel profiles 100 define flow channels 74 between the first and second sidewalls 52, 54 as depicted, for example, by the lines and arrows in FIG. 6, and that extend from a portion of the interior 60 to the opening 66a-66c of the pouch 50. The flow channel profiles 100 and corresponding grooves 102 may be straight or curved. The profiles 100 may be parallel to one another, or in other embodiments not shown, may extend radially away from the opening 66a-66c in an expanding sunburst configuration, or may have any other configuration such that the continuous flow channels 74 provide fluid communication between the opening 66a-66c and a portion of the pouch interior 60 spaced from the opening when the pouch 50 is under vacuum pressure.

[0037] Referring next to FIGS. 7 and 8, the flow channel profiles 100a-100e each have a first component 106 that extends from the inner surface 72 of the first sidewall 52 or from the first side 94 of the base member 96 that is affixed to the inner surface 72 of the first sidewall 52, as disclosed in detail above with respect to FIG. 3. Each profile 100a-100e also includes

a second component 108 that extends laterally from the first component 106 proximate a distal end 110 thereof. The second component 108 may have a straight or curved cross section and may extend laterally away from one side of the first component 106, as illustrated in left-most profile 100a in FIG. 8, or may extend laterally away from both sides of the first component 106 as illustrated in right-most profile 100e in FIG. 8.

[0038] Illustratively, the second component 108 may extend laterally away from the first component 106 perpendicular to the first component 106, as shown in profiles 100a and 100e in FIG. 8. In another embodiment, the second component 108 may extend laterally away from the first component 106 at an obtuse angle as illustrated in profiles 100b and 100c in FIG. 8. Further, in a further embodiment, the second component 108 may extend laterally away from the first component 106 at an acute angle as illustrated in profile 100d in FIG. 8. The second component 108 provides increased surface area 112 on a distal end 114 of each profile 100a-100e, and as discussed above, provides additional support area for the second sidewall 54 to assist in preventing collapse thereof into the channel 74 when the pouch 50 is being evacuated.

[0039] Referring next to FIG. 9, in still other embodiments, the second component 108 of each of the flow channel profiles 200a-200c may also extend from an intermediate region 116 of the first component 106 between a base end 118 and the distal end 110 thereof. In one embodiment, the second component 108 may have a straight or curved cross section and may extend laterally away from both sides of the first component 106 as illustrated in left-most profile 200a in FIG. 8, or in other embodiments, may extend laterally away from one side of the first component 106, as illustrated in profiles 200b and 200c in FIG. 9. The second component 108 may extend laterally away from the first component 106 at any non-zero angle with respect to the first component 106, for example, an acute angle, an obtuse angle, or a 90 degree angle. The second component 108 may extend from both sides of the first component 106 and away from the base member 96 as illustrated by left-most flow channel profile 200a in FIG. 9, because such a configuration may provide an increased effective surface area 112 across the distal end 114 of the profile 200a.

-12-

[0040] The flow channel profiles 100a-100e and 200a-200c may be straight or curved. The profiles 100a-100e and 200a-200c may be parallel to one another, or in other embodiments not shown, may extend radially away from the opening 66a-66c in an expanding sunburst configuration, or may have any other configuration such that the continuous flow channels 74 provide fluid communication between the opening 66a-66c and a portion of the pouch interior 60 spaced from the opening when the pouch 50 is under vacuum pressure.

[0041] Although not shown, one or both sidewalls, such as the second sidewall 54, may also be embossed or otherwise textured with a pattern, such as a diamond pattern, on one or both surfaces spaced between the bottom edge 56b and the closure mechanism 62, or a separate textured and embossed patterned wall may be used to provide additional flow channels (not shown) within the pouch interior 64. Illustrative flow channels useful in the present invention include those disclosed in Zimmerman et al. U.S. Patent Application Publication No. 2005/0286808 and Tilman et al. U.S. Patent Application Publication No. 2006/0048483.

[0042] In one embodiment, the first and second sidewalls 52, 54 and/or the closure mechanism 62 are formed from thermoplastic resins by known extrusion methods. For example, the sidewalls 52, 54 may be independently extruded of thermoplastic material as a single continuous or multi-ply web, and the closure mechanism 62 may be extruded of the same or different thermoplastic material(s) separately as continuous lengths or strands. Illustrative thermoplastic materials include polypropylene (PP), polyethylene (PE), metallocene-polyethylene (mPE), low density polyethylene (LDPE), linear low density polyethylene (LLDPE), ultra low density polyethylene (ULDPE), biaxially-oriented polyethylene terephthalate (BPET), high density polyethylene (HDPE), polyethylene terephthalate (PET), among other polyolefin plastomers and combinations and blends thereof. Further, the inner surfaces 152, 154 of the respective sidewalls 52, 54 or a portion or area thereof may, for example, be composed of a polyolefin plastomer such as an AFFINITY™ resin manufactured by Dow Plastics. Such portions or areas include, for example, the area of one or both of the sidewalls 52, 54 proximate and parallel to the closure mechanism 60 to provide an additional cohesive seal between the sidewalls when the pouch 50 is evacuated of

fluid. One or more of the sidewalls 52, 54 in other embodiments may also be formed of air-impermeable film. An example of an air-impermeable film includes a film having one or more barrier layers, such as an ethylene-vinyl alcohol copolymer (EVOH) ply or a nylon ply, disposed between or on one or more of the plies of the sidewalls 52, 54. The barrier layer may be, for example, adhesively secured between the PP and/or LDPE plies to provide a multilayer film. Other additives such as colorants, slip agents, and antioxidants, including for example talc, oleamide or hydroxyl hydrocinnamate may also be added as desired. In another embodiment, the closure mechanism 62 may be extruded primarily of molten PE with various amounts of slip component, colorant, and talc additives in a separate process. The fully formed closure mechanism 62 may be attached to the pouch body using a strip of molten thermoplastic weld material, or by an adhesive known by those skilled in the art, for example. Other thermoplastic resins and air-impermeable films useful in the present invention include those disclosed in, for example, Tilman et al. U.S. Patent application publication No 2006/0048483.

[0043] The protuberances 70, and flow channel profiles 100, 100a-100e, and 200a-200c as disclosed herein may be composed of any thermoplastic material such as would be used for the first and second sidewalls 52 and 54 of the pouch 50 as disclosed herein. Illustratively, the protuberances 70, and flow channel profiles 100, 100a-100e, and 200a-200c may, for example, be composed of a polyolefin plastomer such as an AFFINITY™ resin manufactured by Dow Plastics.

[0044] The resealable pouch 50 described herein can be made by various techniques known to those skilled in the art including those described in, for example, Geiger, et al., U.S. Patent No. 4,755, 248. Other useful techniques to make a resealable pouch include those described in, for example, Zieke et al., U. S. Patent No. 4,741,789. Additional techniques to make a resealable pouch include those described in, for example, Porchia et al., U. S. Patent No. 5,012,561. Additional examples of making a resealable pouch as described herein include, for example, a cast post applied process, a cast integral process, and/or a blown process.

INDUSTRIAL APPLICABILITY

[0045] Flow channels within a pouch may be used to evacuate fluid from the pouch, thereby allowing pouch contents, such as food, to remain fresher for extended periods of time. Flow channels allow a vacuum source to reach interior regions of the pouch that are spaced from the vacuum source. The flow channels herein are defined by structures having first and second components that together provide an increased surface area that prevents collapse of an opposing pouch wall when the pouch is subjected to vacuum evacuation.

[0046] Numerous modifications to the present invention will be apparent to those skilled in the art in view of the foregoing description. Accordingly, this description is to be construed as illustrative only and is presented for the purpose of enabling those skilled in the art to make and use the invention and to teach the best mode of carrying out same. The exclusive rights to all modifications which come within the scope of the appended claims are reserved.

We claim:

1. A pouch comprising:
 - first and second pouch walls, the first and second pouch walls defining an interior of the pouch, and an opening to the interior of the pouch being provided in at least one of the first and second pouch walls;
 - a flow channel profile disposed on an inner surface of the first pouch wall; and
 - a complementary groove disposed on an inner surface of the second pouch wall, the complementary groove being configured to releasably engage with the flow channel profile so as to define a flow channel between the first and second pouch walls, wherein the flow channel profile extends between the opening and a portion of an interior of the pouch that is spaced from the opening, and

wherein, when the flow channel profile is releasably engaged with the complementary groove, a tip of the flow channel profile contacts a surface of the complementary groove, and a surface of the flow channel profile that is adjacent to the tip also contacts a surface of the complementary groove.
2. The pouch of claim 1, wherein the flow channel profile is integral with and extends from a first side of a base member, and a second side of the base member is attached to an inner surface of the first pouch wall.
3. The pouch of claim 2, wherein the second side of the base member is attached to the inner surface of the first pouch wall by a thermoplastic weld layer.
4. The pouch of claim 2, wherein the first and second opposing walls are made of a thermoplastic resin.
5. The pouch of claim 1, wherein a plurality of flow channel profiles is separately extruded and applied to an inner surface of the first pouch wall.
6. The pouch of claim 1, further comprising:
 - a valve disposed in the opening; and
 - a resealable closure mechanism disposed proximate to a mouth of the pouch, to seal the pouch, with the first and second pouch walls defining the mouth.

7. The pouch of claim 6, wherein the flow channel is in fluid communication with the valve.
8. The pouch of claim 6, wherein the flow channel profile is segmented.

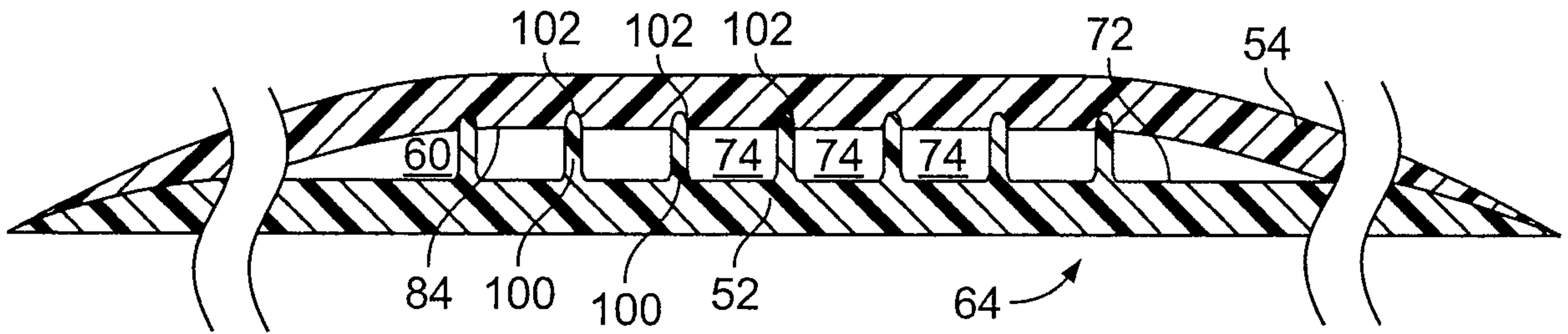

FIG. 5

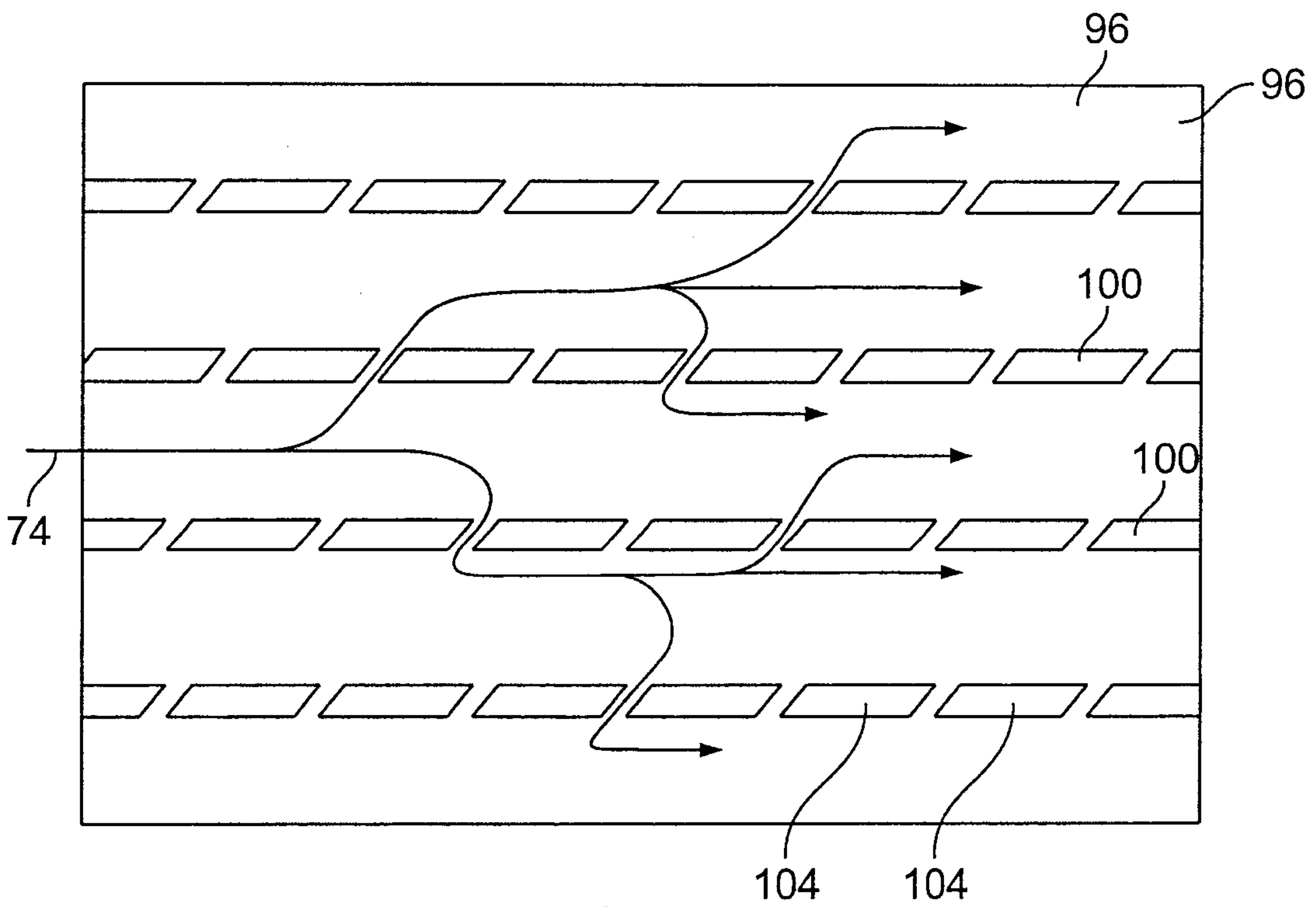

FIG. 6

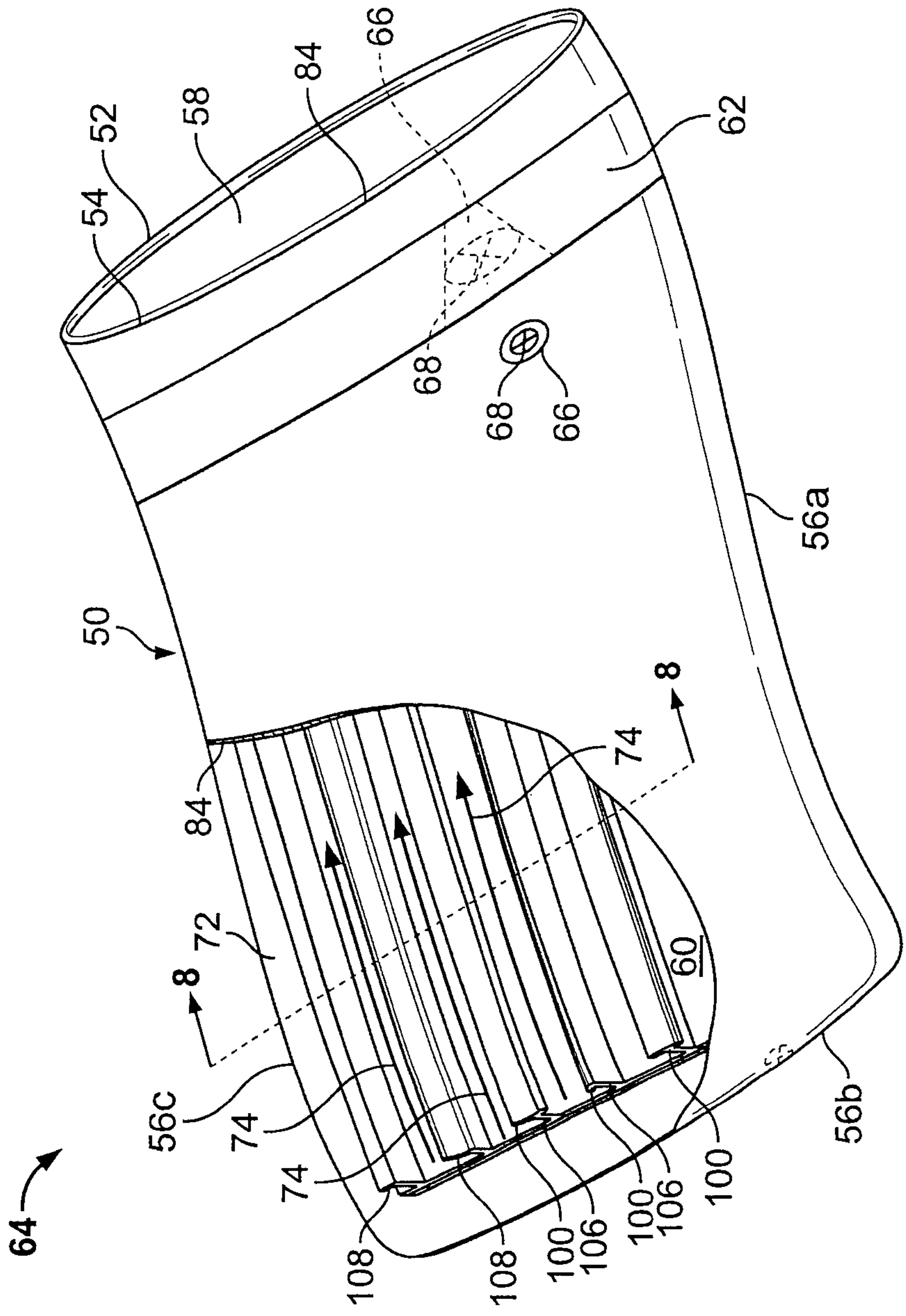

FIG. 7

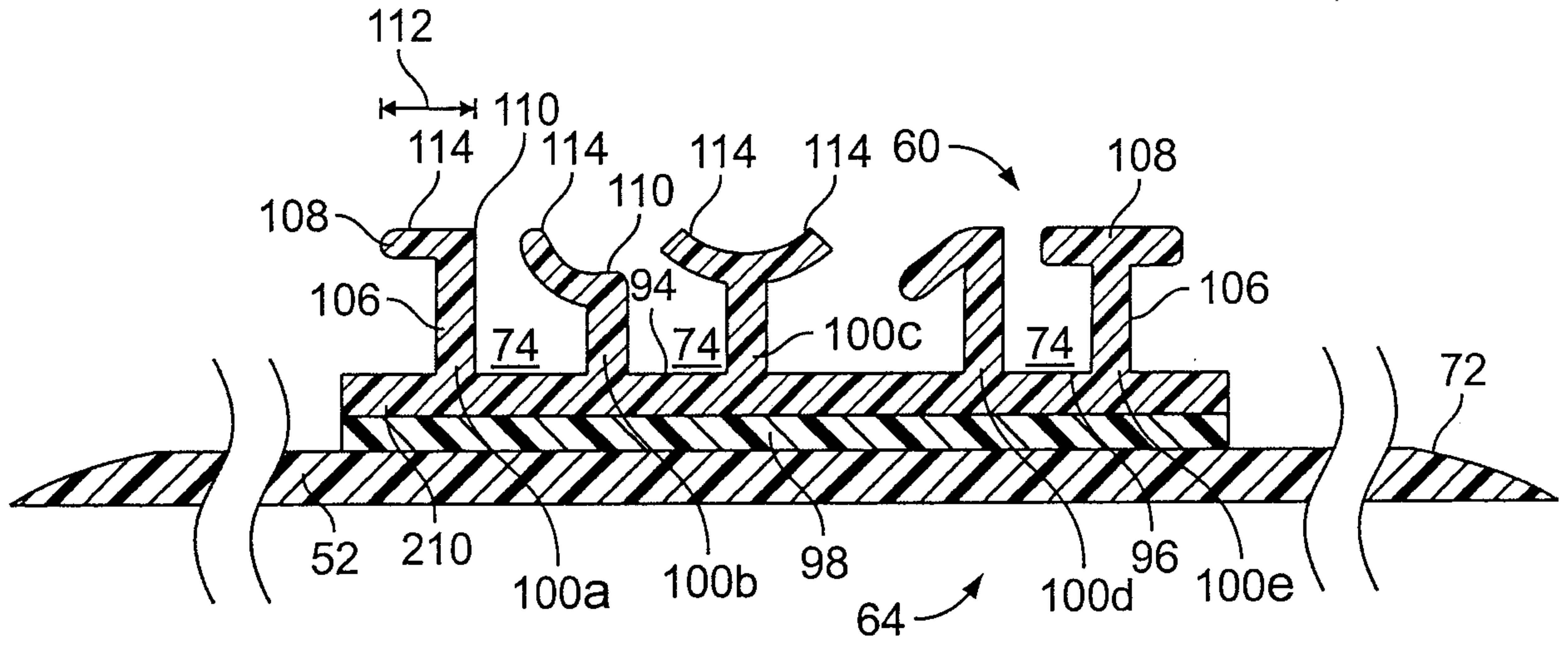

FIG. 8

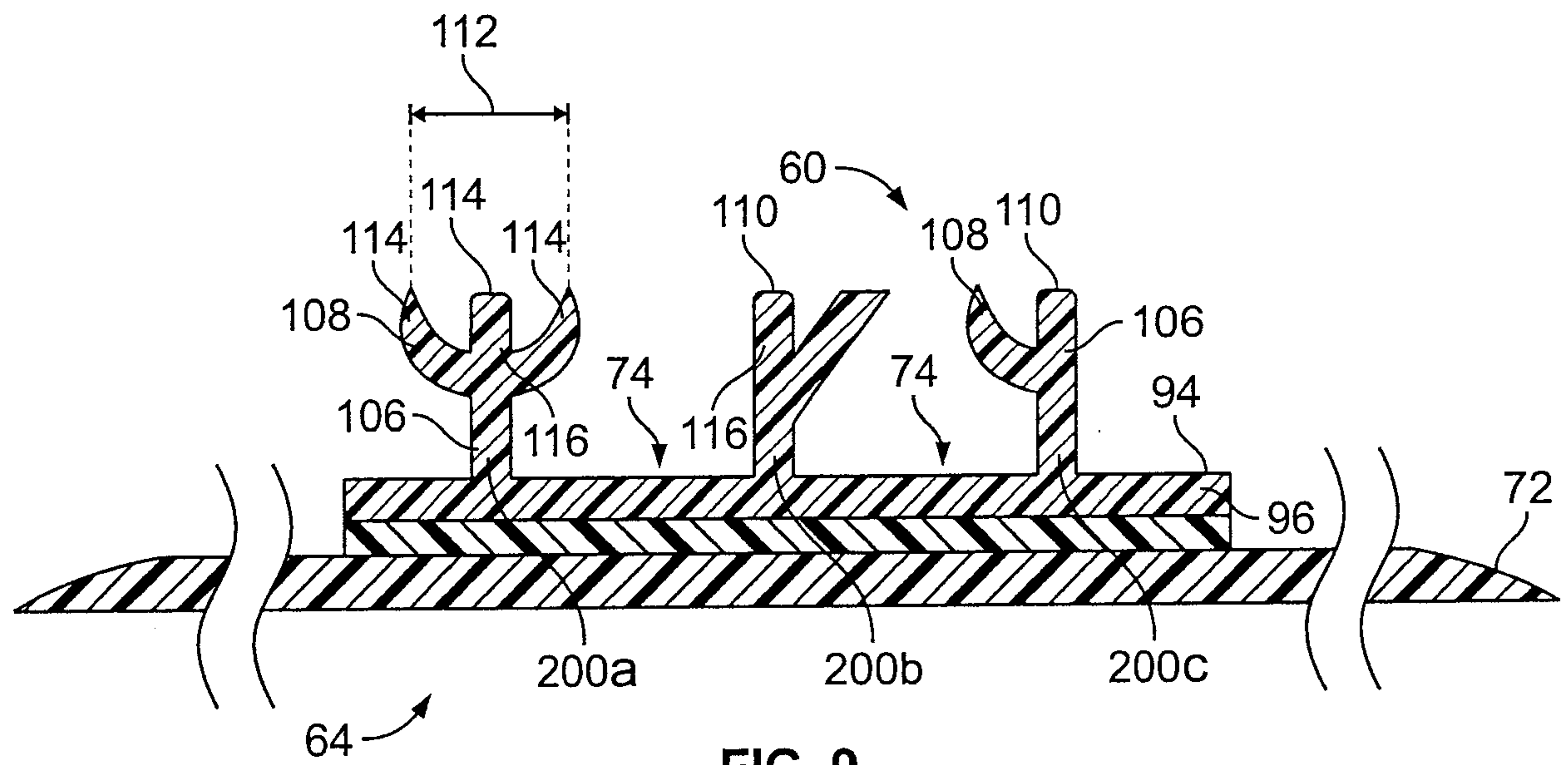

FIG. 9

