



(12) **EUROPEAN PATENT APPLICATION**

(43) Date of publication:  
**28.01.2009 Bulletin 2009/05**

(51) Int Cl.:  
**D06F 58/24<sup>(2006.01)</sup>**

(21) Application number: **07425473.1**

(22) Date of filing: **26.07.2007**

(84) Designated Contracting States:  
**AT BE BG CH CY CZ DE DK EE ES FI FR GB GR HU IE IS IT LI LT LU LV MC MT NL PL PT RO SE SI SK TR**  
 Designated Extension States:  
**AL BA HR MK RS**

(71) Applicant: **Candy S.p.A.**  
**20052 Monza (MI) (IT)**

(72) Inventor: **Fumagalli, Sivano**  
**20052 Monza, Milano (IT)**

(74) Representative: **Leihkauf, Steffen Falk et al**  
**Jacobacci & Partners S.p.A.**  
**Via Senato, 8**  
**20121 Milano (IT)**

(54) **Washer-drier machine**

(57) A washer-drier machine (1) comprises a washing water delivery system (6,7,12,24,25,26) with a plurality of washing flow paths extending from, for example, first and second supply electrovalves (6,7) through corresponding compartments (8,9,10) of a detergent tray (12), to the washing tank (12). The washing flows along

said washing flow paths can be selectively adjusted by means of the electrovalves (6,7). A cooling duct (23) suitable to deliver mains water to the heat exchanger (19,20) branches off from one of the washing flow paths, such that the heat exchanger (19,20) can be selectively supplied by means of the electrovalves (6,7) together with the washing flow path.

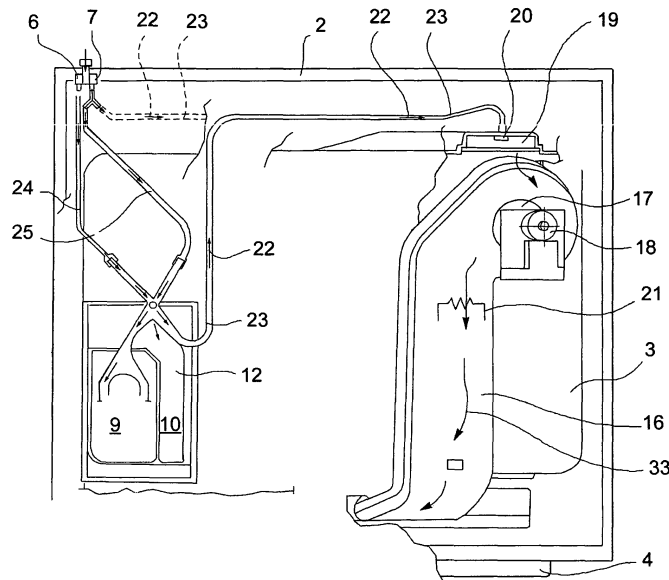

**FIG. 3**

## Description

**[0001]** The present invention relates to a domestic washer-drier machine which provides for washing and drying the laundry.

**[0002]** Domestic washer-drier machines are known to comprise a support and housing structure, a washing tank being housed therein, which is provided with a front opening that can be closed by means of a porthole door that is hinged in front of the housing. Within the washing tank, a basket is pivotally housed about a horizontal or inclined axis for the laundry to be accommodated therein to be washed and/or dried. The basket also defines a front opening that is located such as to match the opening of the washing tank, in order to load/unload the laundry.

**[0003]** The washing tank is suitable to contain the washing liquid during the laundry washing steps, and to be a portion of the drying circuit during the laundry drying step.

**[0004]** In order to allow loading the tank with mains water and detergent and additive substances, a washing water delivery system is provided to be connected to the water system. This washing water delivery system comprises a plurality of electrovalves which are suitable to selectively adjust the supply to a plurality of flow paths extending downstream of these electrovalves through respective compartments of a detergent tray to the washing tank. On the bottom of the washing tank there is provided a drain duct with a discharge pump being associated thereto, which provides for the removal of the washing liquid from the tank and controls, together with the supply electrovalves, the liquid level within the tank. To heat the washing liquid contained within the tank, an electric resistance is provided, which is arranged within the tank in the gap between the tank wall and the laundry basket.

**[0005]** The drying circuit of prior art washer-drier machines typically comprises a suction unit, a heat exchanger and a heating unit with electric resistances intercommunicating by means of a drying circuit.

**[0006]** In such a closed-loop circuit, the air flow generated by the suction unit is heated by the electric resistances and sent to the basket, where it flows through the wet laundry thereby causing the water contained in the fabric to evaporate. In the heat exchanger, generally of the spray or atmospheric type, the humid air is cooled by a cold water flow. Due to this cooling action, the vapour condensates and is collected and discharged together with the cooling water. The de-humidified air is then sucked again by the suction unit and recirculated.

**[0007]** The cooling water is usually supplied to the heat exchanger by means of a cooling duct with a dedicated electrovalve which controls the loading of the mains water in the heat exchanger (condenser).

**[0008]** Prior art drying devices, while being satisfactory under many aspects, however, have a much complicated structure which is due to the overlapping of the three different circuits:

- washing water supply,
- cooling water supply to the heat exchanger,
- drying air circuit,

5 as well as a high number of hydraulic components that increase the manufacturing cost of the appliance.

**[0009]** The object of the present invention is thus to provide a washer-drier machine having such characteristics as to reduce the number of hydraulic components and to simplify the structure thereof.

10 **[0010]** This and other objects are achieved by means of a washer-drier machine according to claim 1. Advantageous embodiments are the object of the dependent claims.

15 **[0011]** According to the invention, the washer-drier machine comprises:

- a washing water delivery system with a plurality of washing flow paths extending from first and second supply electrovalves, through corresponding compartments of a detergent tray, to the washing tank, wherein the washing flows along said washing flow paths are selectively adjustable via said first and second electrovalves,
- 20 - a cooling duct suitable to delivery mains water to the heat exchanger,

wherein the cooling duct branches off from one of said washing flow paths, such that the heat exchanger can be selectively supplied by means of the same first and second electrovalves together with said washing flow path.

30 **[0012]** Thereby, the electrovalve exclusively dedicated to the heat exchanger can be eliminated, the control of the electrovalves can be simplified, and parallel flow paths can be eliminated within certain limits.

**[0013]** In order to better understand the present invention and appreciate the advantages thereof, several embodiments thereof will be described below by way of non-limiting example, with reference to the annexed drawings, in which:

**[0014]** - Fig. 1 is a side sectional view of a washer-drier machine according to an embodiment of the invention;

**[0015]** - Fig. 2 is a front sectional view of the washer-drier machine in Fig. 1;

45 **[0016]** Fig. 3, 4, 5 are top schematic views illustrating the mains water supply system to the tank and heat exchanger according to several embodiments of the invention.

50 **[0017]** With reference to the figures, a washer-drier machine 1 comprises a support and housing structure 2, a washing tank 3 being housed therein, which is provided with a front opening that can be closed by means of a porthole door 4 being hinged in the front of the housing 2. Within the washing tank 3, a basket 5 is pivotally housed about a horizontal or inclined axis, for the laundry to be accommodated therein to be washed and/or dried. The basket 5 also defines a front opening that is located

such as to match the opening of the washing tank 3, in order to load/unload the laundry.

**[0018]** The washing tank 3 is suitable to contain the washing liquid during the laundry washing steps, and to be a portion of the drying circuit during the laundry drying step.

**[0019]** In order to allow loading the tank 3 with mains water and detergent and additive substances, a washing water delivery system is provided to be connected to the water system. This washing water delivery system comprises a plurality of washing flow paths extending from first 6 and second 7 supply electrovalves, through corresponding compartments 8, 9, 10 of a detergent tray 12, to the washing tank 3.

**[0020]** The washing flows along the washing flow paths can be selectively adjusted by means of the first and/or second electrovalve 6, 7.

**[0021]** On the bottom 13 of the washing tank 3, there is provided a drain duct 14 with a discharge pump 15 being associated thereto, which provides for the removal of the washing liquid from the tank 3 and controls, together with the supply electrovalves 6, 7 the level of liquid within the tank 3.

**[0022]** To heat the washing liquid contained within the tank 3, a coiled electric resistance 16 is provided, which is arranged within the tank 3, particularly on the bottom of the latter, in the gap between the tank wall 3 and the laundry basket 5.

**[0023]** The washer-drier machine 1 further comprises a drying circuit with a suction unit, for example a fan impeller 17 driven by an electric motor 18, a heat exchanger, for example a condensation chamber 19 with a spray nozzle 20 suitable to spray or atomize cooling water within the condensation chamber 19, as well as an electric-resistance heating unit 21 which communicate with each other by means of a drying duct 16.

**[0024]** In such a closed-loop circuit, the air flow 22 generated by the suction unit 17, 18 is heated by the electric resistance 21 and sent to the basket 5, where it flows through the wet laundry thereby causing the water contained in the fabric to evaporate. The heat exchanger 19, 20 is arranged downstream of the laundry basket 5 (with reference to the direction of the drying air flow) and cools the wet air blowing from the basket 5, for example by means of the atomized cold water, either dripped or sprayed.

**[0025]** Due to this cooling action, the vapour condensates and is collected and discharged together with the cooling water. The de-humidified air is then sucked again by the suction unit 17, 18 and recirculated.

**[0026]** The heat exchanger 19, 20 is supplied with cooling water 22 by means of a cooling duct 23, which branches off from one of the washing flow paths, such that the heat exchanger 19, 20 can be selectively supplied by means of the first 6 and second 7 electrovalves (in some instances together with the washing flow path from which the cooling duct 23 branches off).

**[0027]** As discussed above, due to the cooling duct 23

branching off from one of the washing flow paths (downstream of the electrovalves provided for adjusting the washing flows and without any electrovalve dedicated only to the condensation function) the electrovalve only dedicated to the heat exchanger can be eliminated and the electrovalve control can be simplified.

**[0028]** Fig. 3 shows an embodiment of the invention in which the detergent tray 12 comprises two compartments, i.e.:

- a LAV compartment 9 arranged on a first lateral side of the detergent tray 12 and intended to accommodate a washing detergent;
- an ADD compartment 10 arranged on a second lateral side of the detergent tray 12 opposite and adjacent to the LAV compartment 9 and intended to accommodate an additive.

**[0029]** A first base duct 24 extends from the first electrovalve 6 to a intersection point 26, preferably aligned with a central partition wall between the LAV 9 and ADD 10 compartments of the detergent tray 12 and a second base duct 25 extends from the second electrovalve 7 to the same intersection point 26. The outlet ends and openings of the first base duct 24 and second base duct 25 in the intersection point 26 are oriented such that:

**[0030]** when the first electrovalve 6 is opened and the second electrovalve 7 is closed, only the first base duct 24 supplies a mains water flow substantially only to the cooling duct 23 that delivers the water flow to the condenser and from the latter to the washing tank 3;

**[0031]** when the first electrovalve 6 is closed and the second electrovalve 7 is opened, only the second base duct 25 delivers a mains water flow substantially only through the LAV compartment 9 to the washing tank 3;

**[0032]** with the first electrovalve 6 opened and the second electrovalve 7 opened, the first base duct 24 and second base duct 25 supply a crossed mains water flow through the compartment ADD 10 in the washing tank 3.

**[0033]** This embodiment is a simplification of the water supply and condensation circuit layout and provides for example that the pre-washing detergent is directly loaded within the tank.

**[0034]** Washing program

**[0035]** During the washing program, with the first electrovalve 6 opened, the water is loaded to the tank to determine the lye level for the pre-washing cycle, while carrying out a cleaning operation of the heat exchanger.

**[0036]** with the second electrovalve 7 opened, the washing detergent is loaded to the tank to carry out the main washing cycle, and with both electrovalves 6, 7 opened, the additives are loaded to the washing tank.

**[0037]** Drying program

**[0038]** During the drying program, with the first electrovalve 6 opened, the cooling water is loaded to the heat exchanger 19, 20.

**[0039]** During the drying step, the heat exchanger 19, 20 can be thus selectively supplied with mains water by

the first electrovalve 6 being opened and the second electrovalve 7 being simultaneously closed. A residual amount of water is conveyed through the ADD compartment 10 of the tray 12 to the washing tank from which it can be drained, for example, together with the condensed water flowing from the condensation chamber 19. The flow rate ratios of the cooling duct 23 to the washing flow path through the ADD compartment 10 can be set by suitably selecting the respective flow resistances within these ducts.

**[0040]** Fig. 4 illustrates a further embodiment of the invention, wherein the detergent tray 12 comprises three compartments, i.e.:

- a PRE compartment 8 arranged on a first lateral side of the detergent tray 12 and intended to accommodate a pre-washing detergent;
- an ADD compartment 10 arranged on a second lateral side of the detergent tray 12 opposite the PRE compartment 8 and intended to accommodate an additive;
- a LAV compartment 9 arranged in the middle of the PRE 8 and ADD 10 compartments and intended to accommodate a washing detergent.

**[0041]** A first base duct 24 extends from the first electrovalve 6 to a intersection point 26 at the middle LAV compartment 9 of the detergent tray 12 and a second base duct 25 extends from the second electrovalve 7 to the same intersection point 26.

**[0042]** In the intersection point 26, the cooling duct 23 is hydraulically connected and substantially axially aligned with the first base duct 24. Furthermore, the cooling duct at least partially extends above the ADD compartment 10 and an opening 28 is formed on the bottom of the cooling duct 23 through which a portion of the cooling flow is supplied to the ADD compartment 10 and from the latter to the washing tank 3.

**[0043]** The outlet ends and openings of the first base duct 24 and second base duct 25 in the intersection point 26 are oriented such that:

**[0044]** with the first electrovalve 6 opened and the second electrovalve 7 closed, only the first base duct 24 supplies a mains water flow only to the cooling duct 23 from which a flow portion is sent to the ADD compartment 10 of the detergent tray 12 and from the latter to the washing tank 3;

**[0045]** with the first electrovalve 6 closed and the second electrovalve 7 opened, only the second base duct 25 delivers a mains water flow substantially only through the PRE compartment 8 to the washing tank 3;

**[0046]** with the first electrovalve 6 opened and the second electrovalve 7 opened, the first base duct 24 and second base duct 25 supply a crossed mains water flow in a resulting central direction substantially only through the compartment LAV 9 to the washing tank 3.

**[0047]** The present invention (Fig. 4) advantageously allows maintaining a three-compartment detergent tray

without increasing the number of electrovalves.

**[0048]** Washing program

**[0049]** During the washing program, with the second electrovalve 7 opened, the pre-washing water and detergent are loaded to the tank in order to determine the level of lye for the pre-washing cycle.

**[0050]** With both electrovalves 6, 7 opened, the washing detergent is loaded to the tank to carry out the main washing cycle, and with the first electrovalve 6 opened, the additives are loaded to the washing tank, while carrying out a cleaning operation of the heat exchanger.

**[0051]** According to a particularly advantageous embodiment, an intermediate compensation tray 34 is arranged between the opening 28 of the duct 23 and the ADD compartment 10. This compensation tray 34 can be in flow communication with the washing tank and delivers at least one part of the water to the ADD compartment 10 only when a determined water level has been reached. This allows either including or excluding the ADD compartment 10 from the flow path, according to the duration of the opening time of the first electrovalve 6.

**[0052]** Drying program

**[0053]** During the drying step, the heat exchanger 19, 20 can be selectively supplied with mains water by the first electrovalve 6 being opened and the second electrovalve 7 being simultaneously closed. A residual amount of water is conveyed through the ADD compartment 10 of the tray 12 or, alternatively, through the compensation tray 34, to the washing tank from which it can be drained, for example together with the condensed water flowing from the condensation chamber 19. The flow rate ratio of the cooling duct 23 to the washing flow path through the ADD compartment 10 and/or compensation compartment 34 downstream of the branching-off point can be set by suitably selecting the respective flow resistances within these ducts and paths.

**[0054]** Fig. 5 illustrates a further embodiment of the invention, in which the detergent tray 12 comprises three compartments, i.e.:

- a LAV compartment 9 arranged on a first lateral side of the detergent tray 12 and intended to accommodate a washing detergent;
- an ADD compartment 10 arranged on a second lateral side of the detergent tray 12 opposite the LAV compartment 9 and intended to accommodate an additive;
- a PRE compartment 8 arranged in the middle between the LAV 9 and ADD 10 compartments and intended to accommodate a pre-washing detergent.

**[0055]** A first base duct 24 extends from the first electrovalve 6 to a intersection point 26 that is arranged substantially aligned with a partition wall 29 separating the middle PRE compartment 8 from the side compartment LAV 9 of the detergent tray 12. A second base duct 25 extends from the second electrovalve 7 to the same intersection point 26.

**[0056]** At the intersection point 26, the cooling duct 23 is hydraulically connected to both base ducts 24, 25 and substantially axially aligned with a resulting direction of a crossed water flow of the two base ducts 24, 25.

**[0057]** In the present specification, by "crossed flow" is meant the vector addition of the two mains water flows that are simultaneously supplied by the first base duct 24 and second base duct 25 at the intersection point 26.

**[0058]** Furthermore, the cooling duct 23 at least partially extends above the ADD compartment 10 and an opening 28 is formed on the bottom of the cooling duct 23 through which a portion of the cooling duct is supplied to the ADD compartment 10 and from the latter to the washing tank 3.

**[0059]** The outlet ends and openings of the first base duct 24 and second base duct 25 in the intersection point 26 are oriented such that:

**[0060]** with the first electrovalve 6 opened and the second electrovalve 7 closed, only the first base duct 24 supplies a mains water flow, preferably through a first intermediate channel 30, only to the PRE compartment 8 and from the latter to the washing tank 3;

**[0061]** with the first electrovalve 6 closed and the second electrovalve 7 opened, only the second base duct 25 supplies a mains water flow, preferably through a second intermediate channel 31, only to the LAV compartment 9 and from the latter to the washing tank 3;

**[0062]** with the first electrovalve 6 opened and the second electrovalve 7 opened, the first base duct 24 and the second base duct 25 supply a crossed mains water flow in a central resulting direction only to the cooling duct 23 from which a flow portion is sent to the ADD compartment 10 of the detergent tray 12 and from the latter to the washing tank 3;

**[0063]** Washing program

**[0064]** During the washing program, with the first electrovalve 6 opened, the pre-washing water and detergent are loaded to the tank in order to determine the level of lye for the pre-washing cycle.

**[0065]** With the second electrovalve 7 opened, the washing detergent is loaded to the tank to carry out the main washing cycle, and with both electrovalves 6, 7 opened, the additives are loaded to the washing tank, while carrying out a cleaning operation of the heat exchanger.

**[0066]** Drying program

**[0067]** During the drying step, the heat exchanger 19, 20 can be selectively supplied with mains water by the first electrovalve 6 and second electrovalve 7 being simultaneously opened. An amount of residual water is conveyed through the ADD compartment 10 of the tray 12 to the washing tank 3 from which it can be drained, for example, together with the condensed water flowing from the condensation chamber 19. The flow rate ratios of the cooling duct 23 to the washing flow path through the ADD compartment 10 downstream of the branching-off point can be set by suitably selecting the respective flow resistances in these ducts and paths.

**[0068]** In accordance with an embodiment that can be implemented in each of the solutions illustrated in Fig. 3, 4 and 5, this flow rate ratio of the cooling duct 23 to the washing flow path through the ADD compartment 10 is selected such that the amount of liquid passing through the ADD compartment ADD 10 is barely enough to convey the additive from the detergent tray 12 to the washing tank 3.

**[0069]** In accordance with an embodiment, the intersection point of the base ducts 24, 25, any intermediate channel, and the compartments of the tray 12 are shaped and positioned such that, with the first and second electrovalves opened, at least one first portion of the resulting crossed flow is supplied to the LAV compartment 9 and to the PRE compartment 8. Thereby, during the drying step, a small water counter-flow can be provided along one or more walls of the washing tank 3 which is suitable to remove the yarns carried by the drying air flow and deposited onto the walls of the washing tank 3.

**[0070]** In accordance with an embodiment of the invention, the condensation unit of the drying circuit comprises, in addition to the spray heat exchanger 19, 20, a further heat exchanger provided by a cold water free surface 32 that is collected and held on the bottom of the washing tray 3. In this case, the drying program of the washer-drier machine 1 is configured such as to hold the cold water free surface 32 at a safety distance from the basket and to drain the water on the tank bottom, by means of the discharge pump 15, as a function of the level and temperature of the water 32. Thereby, the heating of the cold water on the bottom of tank 3 as well as the increased level due to the formation of condensate are taken into account.

**[0071]** In accordance with an aspect of the present invention, the volume of cold water 32 on the bottom of the washing tank 3 can be loaded by means of one of the washing flow paths through one or more of the compartments of the detergent tray 12. Thereby, and due to the cooling duct 23 branching off from one of the washing flow paths, the spray heat exchanger and the free condensation surface on the bottom of tank 3 can be supplied independently from each other.

**[0072]** The washer-drier machine according to the invention has a number of advantages.

**[0073]** Particularly, it allows reducing the number of hydraulic components and simplifying the control programs of the laundry washing and drying steps.

**[0074]** In accordance with several of the embodiments described herein, a double result is obtained of effectively cooling the drying air and eliminating the yarns deposits on the washing tank walls by means of a counter-flow that takes place automatically and simultaneously with the mains water supply to heat exchanger.

**[0075]** Obviously, to the washer-drier machine according to the present invention, those skilled in the art, aiming at meeting contingent and specific requirements, may carry out further modifications and variations, all being however contemplated within the scope of protection of

the invention, such as defined in the annexed claims.

## Claims

1. A washer-drier machine (1) for washing and drying the laundry comprising:

- a washing tank (3) suitable to contain the washing liquid;
- a basket (5) suitable to accommodate the laundry and being pivotally supported within the washing tank (3);
- a drying circuit (16, 17, 18, 19, 20, 21) with a suction unit (17, 18), a heat exchanger (19, 20) and a heating unit (21) which communicate with each other by means of a drying duct (16), said drying circuit being suitable of delivering a drying air flow (33) through said basket (5),
- a washing water delivery system (6, 7, 12, 24, 25, 26) with a plurality of washing flow paths extending from first (6) and second (7) supply electrovalves, through corresponding compartments (8, 9, 10) of a detergent tray (12), to the washing tank (3), wherein the washing flows along said flow paths are selectively adjustable via said first (6) and second (7) electrovalves,
- a cooling duct (23) suitable to delivering mains water to the heat exchanger (19, 20),

**characterized in that** said cooling duct (23) branches off from one of said washing flow paths (24; 25; 26; 8; 9; 10), such that the heat exchanger (19, 20) can be selectively supplied by means of the first (6) and/or second (7) electrovalves together with said washing flow path (24; 25; 26; 8; 9; 10).

2. The washer-drier machine (1) according to claim 1, wherein said cooling duct (23) branches off from the washing flow path (24; 25; 26; 10) which passes through an ADD compartment (10) of the detergent tray (12) which is intended to contain a washing additive, such that, simultaneously with the supply of mains water to the heat exchanger (19, 20), a residual portion of water passes through said ADD compartment (10) to the washing tank (2).
3. The washer-drier machine (1) according to claim 1, wherein said cooling duct (23) branches off from the washing flow path (24; 25; 26; 8) which passes through a PRE compartment (8) of the detergent tray (12) which is intended to contain a pre-washing detergent, such that, simultaneously with the supply of mains water to the heat exchanger (19, 20), a residual portion of water passes through said PRE compartment (8) to the washing tank (3).
4. The washer-drier machine (1) according to any pre-

ceding claim; wherein a first base duct (24) extends from the first electrovalve (6) to a intersection point (26) at the detergent tray (12) and a second base duct (25) extends from the second electrovalve (7) to the same intersection point (26), wherein the outlet ends and openings of the first base duct (24) and second base duct (25) in the intersection point (26) are oriented such as to be capable of selectively supply one of a plurality of compartments (8, 9, 10) of said detergent tray (12), respectively, by means of separated water flows flowing in a direction corresponding to the orientation of the individual base duct (24; 25) in the intersection point (26) and/or by means of overlapped water flows of both base ducts (24, 25) that can be adjusted by means of said first (6) and second (7) electrovalves.

5. The washer-drier machine (1) according to claim 4, wherein the cooling duct (23) branches off from said first (24) and/or second (25) base duct at said intersection point (26).
6. The washer-drier machine (1) according to claim 4, wherein the cooling duct (23) branches off from a washing flow downstream of the intersection point (26).
7. The washing machine (1) according to the preceding claim, wherein the branching-off point is formed within the detergent tray (12).
8. The washer-drier machine (1) according to the preceding claim, wherein the drying program is configured such that a residual amount of water, conveyed through the PRE compartment (8) of the tray (12) to the washing tank (3) is drained, together with the condensate water flowing from the heat exchanger (19, 20).
9. The washer-drier machine according to claim 5 or 6, wherein the detergent tray (12) comprises two compartments, i.e. a LAV compartment (9) intended to accommodate a washing detergent and an ADD compartment (10) intended to accommodate an additive, wherein the outlet ends and openings of the first base duct (24) and second base duct (25) in the intersection point (26) are oriented such that:
- with the first electrovalve (6) opened and the second electrovalve (7) closed, the first base duct (24) supplies a mains water flow substantially only through the ADD compartment (10) to the washing tank (3);
  - with the first electrovalve (6) closed and the second electrovalve (7) opened, the second base duct (25) supplies a mains water flow substantially only through the LAV compartment (9)

to the washing tank (3);

wherein the cooling duct (23) branches off from a point in the ADD compartment (10) downstream of the intersection point (26).

10. The washer-drier machine (1) according to claim 9, wherein the drying program is configured such that a residual amount of water, conveyed through the ADD compartment (10) of the tray (12) to the washing tank (3) is drained, together with the condensate water flowing from the heat exchanger (19, 20).

11. The washer-drier machine according to claim 5 or 6, wherein the detergent tray (12) comprises two compartments, i.e. a LAV compartment (9) intended to accommodate a washing detergent and an ADD compartment (10) intended to accommodate an additive, wherein the outlet ends and openings of the first base duct (24) and second base duct (25) in the intersection point (26) are oriented such that:

- with the first electrovalve (6) opened and the second electrovalve (7) closed, the first base duct (24) supplies a mains water flow substantially only through the ADD compartment (10) to the washing tank (3) ;

- with the first electrovalve (6) closed and the second electrovalve (7) opened, the second base duct (25) supplies a mains water flow substantially only through the LAV compartment (9) to the washing tank (3) ;

wherein an inlet opening (27) of the cooling duct (23) is arranged in the resulting direction of a crossed flow that is simultaneously supplied through the first base duct (24) and second base duct (25).

12. The washer-drier machine (1) according to claim 5 or 6, wherein the detergent tray (12) comprises three compartments, i.e. a PRE compartment (8) intended to accommodate a pre-washing detergent, an ADD compartment (10) intended to accommodate an additive, and a LAV compartment (9) intended to accommodate a washing detergent, wherein, in the intersection point (26), the cooling duct (23) is hydraulically connected and substantially axially aligned with the first base duct (24) and at least partially extends above the ADD compartment (10) and an opening (28) is formed on the bottom of the cooling duct (23) through which a portion of the cooling flow can be supplied to the ADD compartment (10) and from the latter to the washing tank (3), wherein the outlet ends and openings of the first base duct (24) and second base duct (25) in the intersection point (26) are oriented such that:

- with the first electrovalve (6) opened and the second electrovalve (7) closed, the first base duct (24) supplies a mains water flow to the cooling duct (23) from which a flow portion is sent to the ADD compartment (10) of the detergent tray (12) and from the latter to the washing tank (3);

- with the first electrovalve (6) closed and the second electrovalve (7) opened, the second base duct (25) supplies a mains water flow through the PRE compartment (8) to the washing tank (3);

- with the first electrovalve (6) opened and the second electrovalve (7) opened, the first base duct (24) and second base duct (25) supply a crossed mains water flow in a resulting direction through the LAV compartment (9) to the washing tank (3).

13. The washer-drier machine (1) according to claim 12, wherein the drying program is configured such that a residual amount of water, conveyed through the ADD compartment (10) of the tray (12) to the washing tank (3) is drained, together with the condensate water flowing from the heat exchanger (19, 20).

14. The washer-drier machine (1) according to claim 5 or 6, wherein the detergent tray (12) comprises three compartments, i.e. a LAV compartment (9) intended to accommodate a washing detergent, an ADD compartment (10) intended to accommodate an additive, and a PRE compartment (8) intended to accommodate a pre-washing detergent, wherein, in the intersection point (26), the cooling duct (23) is hydraulically connected to both base ducts (24, 25) and substantially axially aligned with a resulting direction of a crossed water flow of the two base ducts (24, 25), wherein the cooling duct (23) at least partially extends above the ADD compartment (10) and an opening (28) is formed on the bottom of the cooling duct (23) through which a portion of the cooling flow can be supplied to the ADD compartment (10) and from the latter to the washing tank (3).

wherein the outlet ends and openings of the first base duct (24) and second base duct (25) in the intersection point (26) are oriented such that:

- with the first electrovalve (6) opened and the second electrovalve (7) closed, the first base duct (24) supplies a mains water flow to the PRE compartment (8) and from the latter to the washing tank (3);

- with the first electrovalve (6) closed and the second electrovalve (7) opened, the second base duct (25) supplies a mains water flow to the LAV compartment (9) and from the latter to the washing tank (3);

- with the first electrovalve (6) opened and the

second electrovalve (7) opened, the first base duct (24) and the second base duct (25) supply a crossed mains water flow in a resulting direction to the cooling duct (23) from which a flow portion is sent to the ADD compartment (10) of the detergent tray (12) and from the latter to the washing tank (3). 5

15. The washer-drier machine according to any preceding claim, wherein the condensation unit of the drying circuit comprises, in addition to said first heat exchanger (19, 20), a further heat exchanger provided by means of a cold water free surface (32) on the bottom of the washing tank (3), 10  
wherein the cold water volume (32) on the bottom of the washing tank (3) can be loaded by means of one of the washing flows through one or more of the compartments of the detergent tray (12). 15

16. The washer-drier machine (1) according to any preceding claim, wherein said first heat exchanger (19, 20) and the condensation free surface (32) on the bottom of the tank (3) can be supplied with mains cold water independently from each other. 20

25

30

35

40

45

50

55

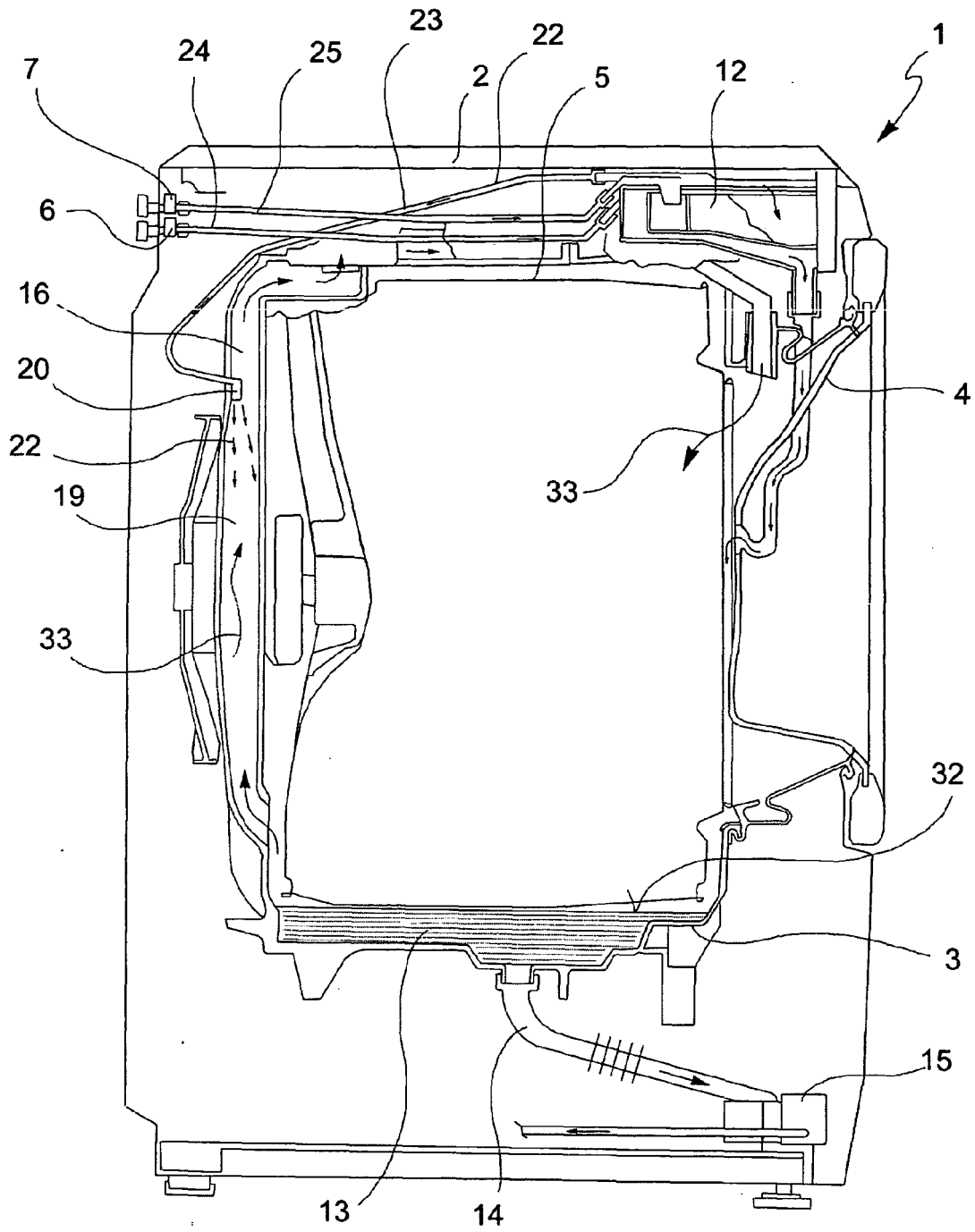

FIG. 1



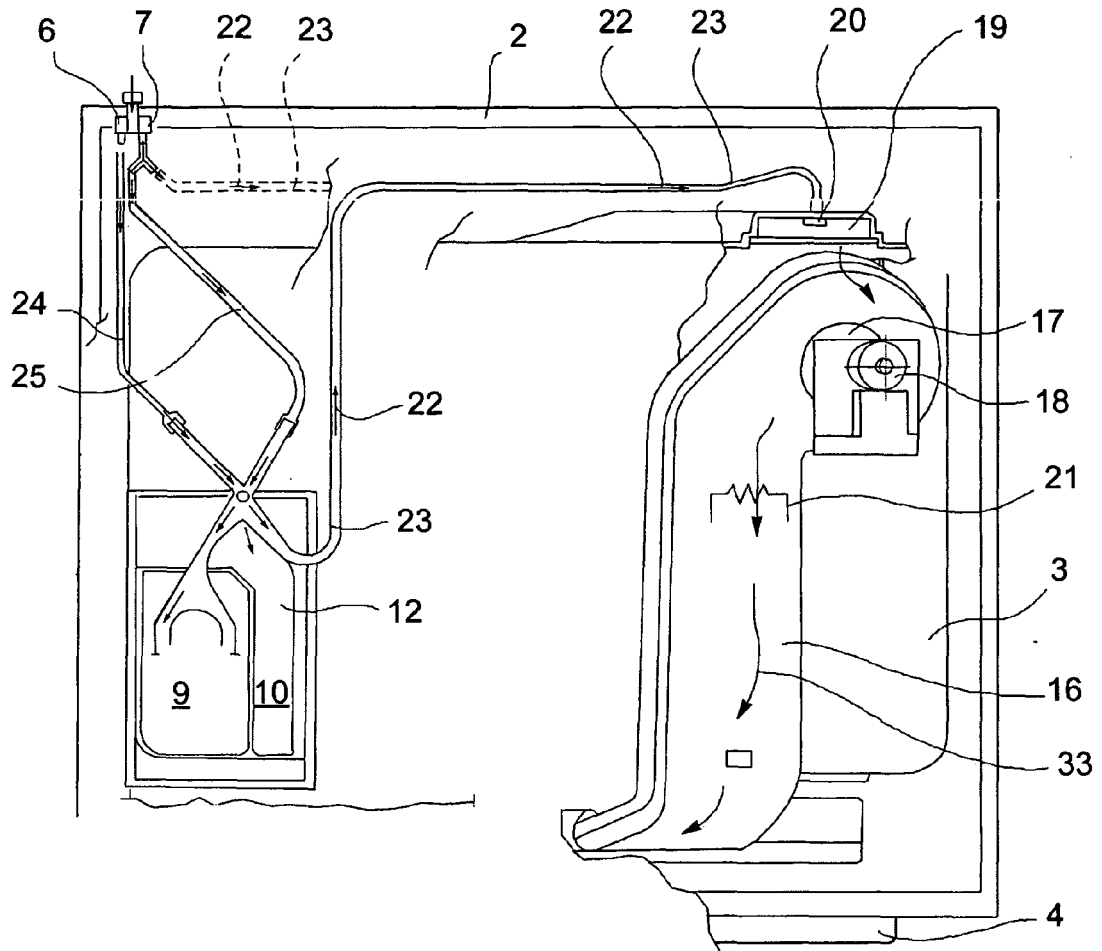

FIG. 3

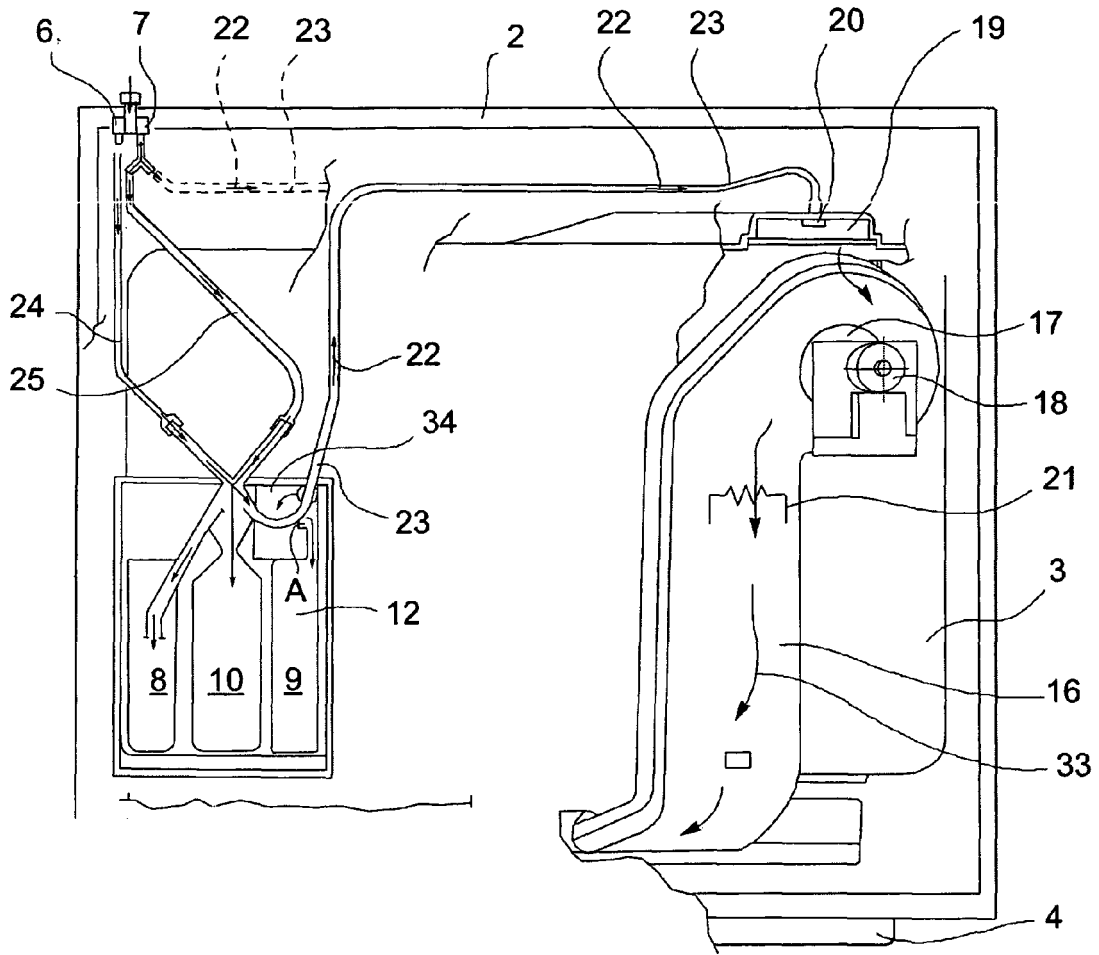

FIG. 4

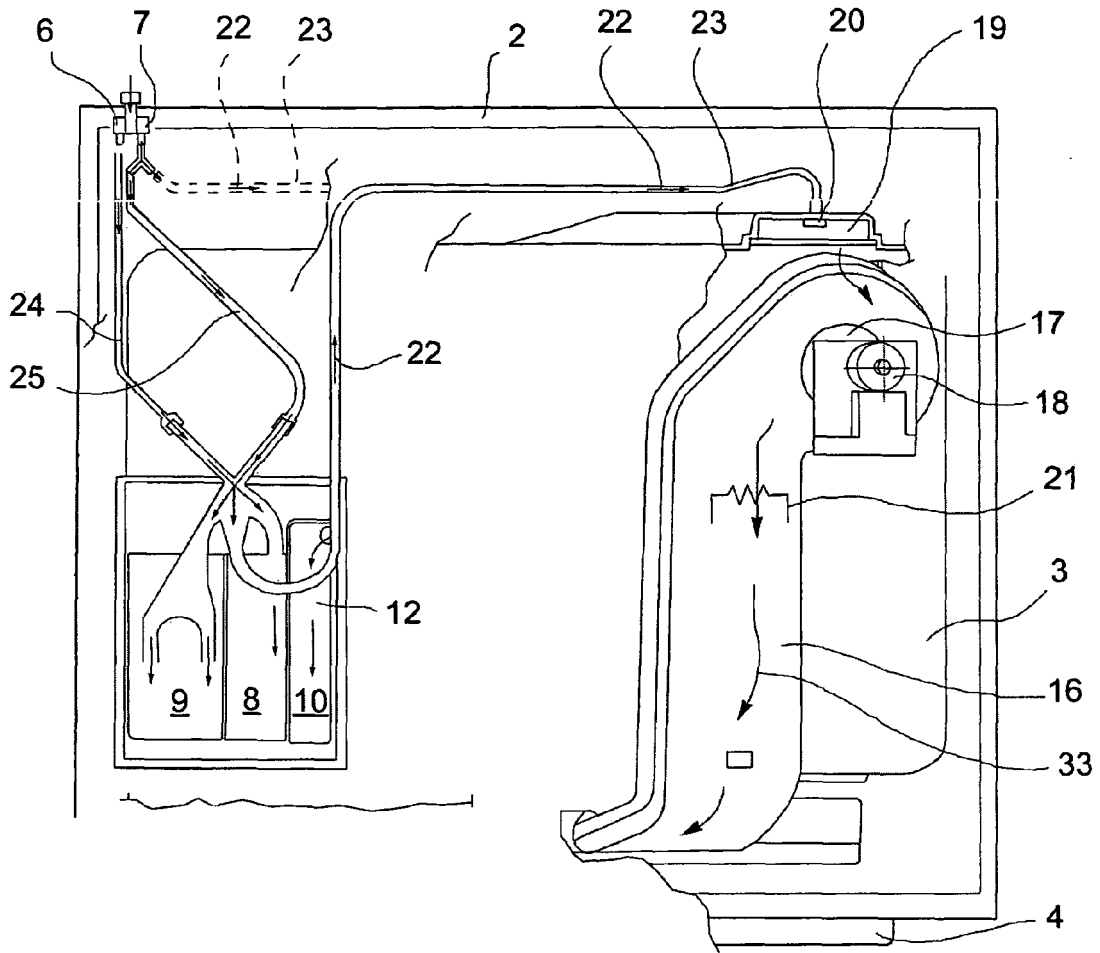

FIG. 5



DOCUMENTS CONSIDERED TO BE RELEVANT			
Category	Citation of document with indication, where appropriate, of relevant passages	Relevant to claim	CLASSIFICATION OF THE APPLICATION (IPC)
X	EP 1 698 722 A (SAMSUNG ELECTRONICS CO LTD [KR]) 6 September 2006 (2006-09-06)	1-3	INV. D06F58/24
A	paragraphs [0020]-[0035]; claims 1, 17; abstract; figures	4-16	
A	----- DE 15 85 939 A1 (SIEMENS ELEKTROGERAETE GMBH) 25 September 1969 (1969-09-25)	1-16	
A	page 1, line 1 - page 2, line 9; page 2, line 27 - page 5, last line; figures		
A	----- DE 89 02 051 U1 (INDUSTRIE ZANUSSI S.P.A., PORDENONE, UDINE, IT)	1-16	
A	6 April 1989 (1989-04-06)		
A	page 3, line 11 - page 4, line 28; figure		
A	----- EP 1 197 592 A (ELECTROLUX ZANUSSI ELETTRODOME [IT])	1-16	
A	17 April 2002 (2002-04-17)		
A	paragraphs [0001], [0019]; claims; abstract; figures		
A	----- EP 0 252 323 A (ZANUSSI A SPA INDUSTRIE [IT]) 13 January 1988 (1988-01-13)	1-16	TECHNICAL FIELDS SEARCHED (IPC)
A	column 1, lines 1,2; column 3, line 20 - column 4, line 43; figure 1		D06F
A	----- GB 1 112 337 A (WHIRLPOOL CO)	1-16	
A	1 May 1968 (1968-05-01)		
A	* the whole document *		
A	----- CH 527 950 A (SIEMENS ELEKTROGERAETE GMBH [DE]) 15 September 1972 (1972-09-15)	1-16	
A	* the whole document *		
-----			
The present search report has been drawn up for all claims			
Place of search		Date of completion of the search	Examiner
Munich		28 November 2007	Clivio, Eugenio
CATEGORY OF CITED DOCUMENTS			
X : particularly relevant if taken alone		T : theory or principle underlying the invention	
Y : particularly relevant if combined with another document of the same category		E : earlier patent document, but published on, or after the filing date	
A : technological background		D : document cited in the application	
O : non-written disclosure		L : document cited for other reasons	
P : intermediate document		& : member of the same patent family, corresponding document	

**ANNEX TO THE EUROPEAN SEARCH REPORT  
ON EUROPEAN PATENT APPLICATION NO.**

EP 07 42 5473

This annex lists the patent family members relating to the patent documents cited in the above-mentioned European search report. The members are as contained in the European Patent Office EDP file on  
The European Patent Office is in no way liable for these particulars which are merely given for the purpose of information.

28-11-2007

Patent document cited in search report		Publication date	Patent family member(s)	Publication date
EP 1698722	A	06-09-2006	CN 1827904 A	06-09-2006
			JP 2006239401 A	14-09-2006
			KR 20060097210 A	14-09-2006
			US 2006195989 A1	07-09-2006
-----				
DE 1585939	A1	25-09-1969	NONE	
-----				
DE 8902051	U1	06-04-1989	FR 2627782 A3	01-09-1989
			GB 2216245 A	04-10-1989
			IT 1220741 B	21-06-1990
-----				
EP 1197592	A	17-04-2002	IT PN20000059 A1	10-04-2002
-----				
EP 0252323	A	13-01-1988	DE 3768722 D1	25-04-1991
			IT 1201780 B	02-02-1989
-----				
GB 1112337	A	01-05-1968	NONE	
-----				
CH 527950	A	15-09-1972	BE 775546 A1	16-03-1972
			DE 2105838 A1	24-08-1972
			ES 201015 Y	16-01-1976
			IT 946795 B	21-05-1973
-----				