

Aug. 25, 1964

J. E. BURBANK
METHOD OF AND APPARATUS FOR MAKING AND
MATING COILS OF FILAMENTARY MATERIAL

3,145,523

Filed March 25, 1963

3 Sheets-Sheet 1

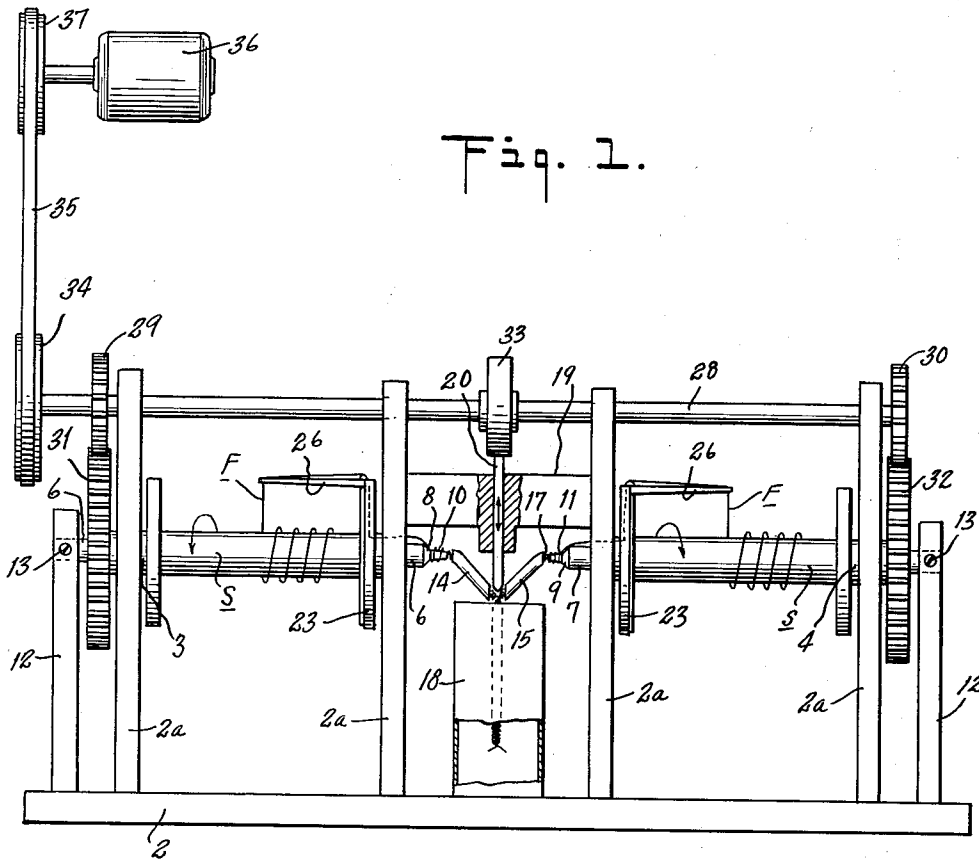

Fig. 1.

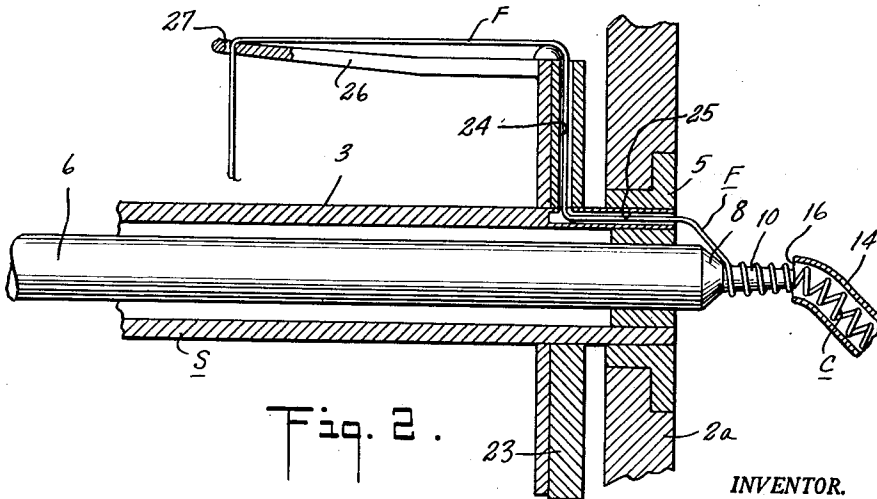

Fig. 2.

INVENTOR.
JOHN E. BURBANK
BY *R. E. Meach*
ATTORNEY

Aug. 25, 1964

J. E. BURBANK
METHOD OF AND APPARATUS FOR MAKING AND
MATING COILS OF FILAMENTARY MATERIAL

3,145,523

Filed March 25, 1963

3 Sheets-Sheet 2

Fig. 3.

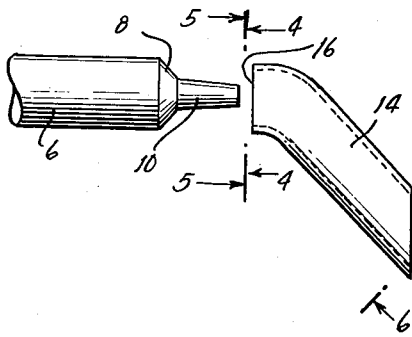

Fig. 4.

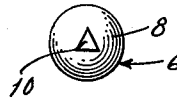

Fig. 5.

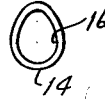

Fig. 6.



Fig. 7.

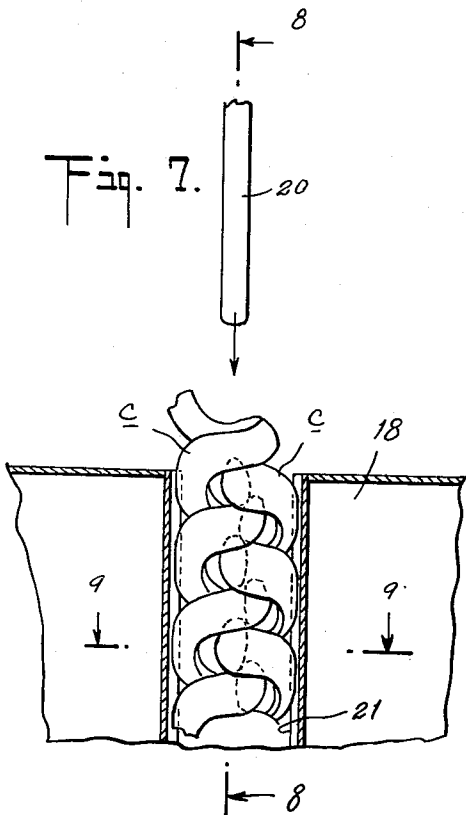
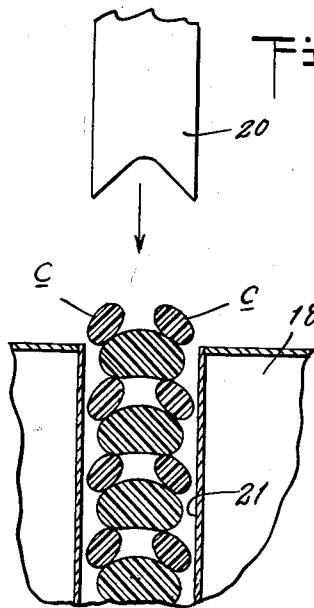

Fig. 8.



INVENTOR.
JOHN E. BURBANK
BY
R. E. Meech
ATTORNEY

Aug. 25, 1964

J. E. BURBANK
METHOD OF AND APPARATUS FOR MAKING AND
MATING COILS OF FILAMENTARY MATERIAL

3,145,523

Filed March 25, 1963

3 Sheets-Sheet 3

Fig. 9.

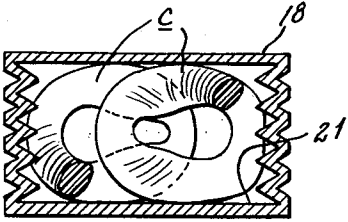

Fig. 10.



Fig. 11.

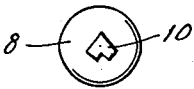

Fig. 12.



Fig. 13.



Fig. 14.

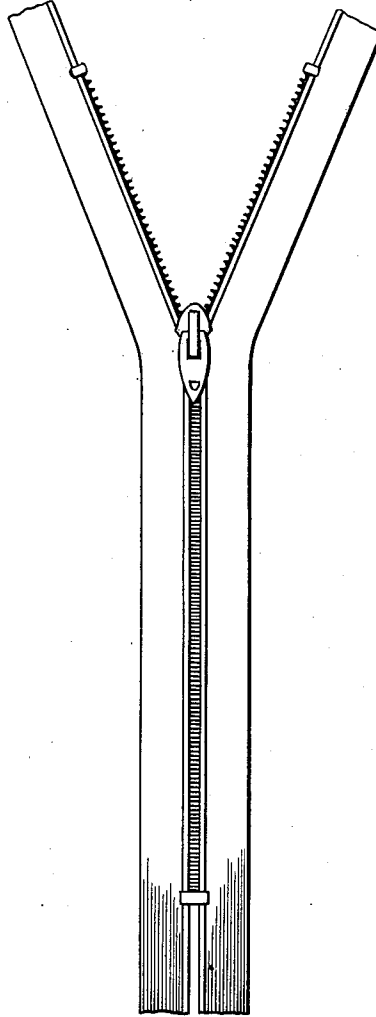

INVENTOR.
JOHN E. BURBANK
BY *R. E. Speck*
ATTORNEY

1

3,145,523

METHOD OF AND APPARATUS FOR MAKING AND MATING COILS OF FILAMENTARY MATERIAL

John E. Burbank, Stamford, Conn.
(Middlebury Road, Middlebury, Conn.)
Filed Mar. 25, 1963, Ser. No. 268,854
13 Claims. (Cl. 57—1)

This invention relates to an improved method of and apparatus for making coils of filamentary material and, particularly, to an improved method of and apparatus for making interlocking coils of filamentary material, such as nylon and other plastic filaments, wire and the like which are suitable for use as interlocking fastening elements for slide fasteners.

This application is a continuation-in-part of my pending patent application Serial No. 58,274, filed September 26, 1960, entitled "Method of and Apparatus for Making and Mating Coils of Filamentary Material," now abandoned.

Heretofore, it has been suggested to use machines, similar to braiding machines, for the formation of interlocking coils of filamentary material, which machines include a post or mandrel around which are passed, in suitable orbits, spools carrying the filaments from which the coils are made, but such machines have not been entirely satisfactory. In order to enable the spools to move around the mandrel, it is necessary that they be mounted on carriers which include interrupted guide rings to enable one ring to pass through the other. Such machines have a number of disadvantages when used to manufacture interlocking coils. Inasmuch as the spools of filaments must be mounted eccentrically of the axes of the carriers to enable the spools to move orbitally around the mandrel, the carriers are inherently unbalanced. When the carriers are balanced in order to compensate for the weight of full spools of the filament, they become progressively more unbalanced as the filament is withdrawn from the spools, thereby setting up vibrations in the apparatus and preventing high speed operation of the machine. Also, such machines were subject to wear after a short period of use and were difficult to keep in adjustment and to maintain.

The segmental or interrupted arrangement of the carriers also introduces a structural weakness in the machine which appears upon attempts to operate the machine at high speed. The ring elements expand due to centrifugal force and bind in the tracks in which they are mounted. Accordingly, the maximum speed of operation of the machine and the productive capacity of the apparatus or machine are limited.

Accordingly, it is one of the objects of the present invention to provide an improved apparatus for coiling filament which is simple and inexpensive in its construction and at the same time efficient and effective in its use.

It is another object of the invention to provide an improved apparatus for coiling a pair of filaments simultaneously at points directly opposite one another further shaping the coiled filaments, mating the two formed filaments and further shaping, sizing and curing the coiled filaments after they are mated.

In accordance with the present invention, there is provided a pair of stationary mandrels and a pair of rotatable spools having the filament wound therearound. The spools are rotated about their respective axes which are concentric with the respective mandrels whereby the filament is wrapped and coiled around each of the mandrels.

Various other objects and advantages of this invention will be more apparent in the course of the following specification, and will be particularly pointed out in the appended claims.

In the accompanying drawings, there is shown for the

2

purpose of illustration an embodiment which my invention may assume in practice.

In these drawings:

FIG. 1 is a front elevational view of the improved apparatus for coiling filament in accordance with the present invention,

FIG. 2 is an enlarged vertical sectional view through the left side of the apparatus as shown in FIG. 1 showing one of the spindles' mandrel rod and associated mechanism,

FIG. 3 is an elevational view of the end of one of the mandrel rods and the coil shaping tube,

FIG. 4 is a sectional view taken on line 4—4 of FIG. 3,

FIG. 5 is a sectional view taken on line 5—5 of FIG. 3,

FIG. 6 is a sectional view taken on line 6—6 of FIG. 3,

FIG. 7 is a fragmentary elevational view, partly in section, showing the coiled filament, the curing tunnel and push rod,

FIG. 8 is a sectional view taken on line 8—8 of FIG. 7 showing deformation of coils,

FIG. 9 is a sectional view taken on line 9—9 of FIG. 7,

FIGS. 10 to 13 are end views of various types of mandrel rods that may be used in coiling the filament in accordance with the present invention, and

FIG. 14 is a plan view of a completed slide fastener of the type to which the present invention relates.

The present invention will be described with reference to the formation of two interlocking coils by means of two filaments or strands of a plastic or similar material to form the coil fastening elements of a pair of stringers for a slide fastener of a type shown in the Nicholas Wahl U.S. Patent No. 2,300,442, issued November 3, 1942.

Referring more particularly to the drawings, there is shown in FIG. 1 the improved apparatus of the present invention which may include a base 2 which is supported on a table or legs as may be desired. Above this base 2 there is arranged a pair of oppositely disposed hollow shafts 3 and 4 which are rotatably mounted in suitable bearings 5, as more clearly shown in FIG. 2, arranged in upwardly extending supporting members or brackets 2a carried by the base 2.

There is arranged axially of the shafts 3 and 4, a pair of stationary spindles 6 and 7, respectively. Each of the spindles 6 and 7 is in the form of a mandrel having a conical tip, as at 8 and 9, respectively, on the inner end thereof from which extends a rod or needle 10 and 11, respectively, of small diameter and of any desired cross section, as shown in FIGS. 4 and 10 through 13 of the drawings. Thus, it will be seen that the mandrel rods 10 and 11 are disposed directly opposite and in alignment with one another and concentric with the shafts 3 and 4. The outer ends of these spindles 6 and 7 are shown supported by upwardly extending members or brackets 12 carried by the base 2 at each end thereof and these spindles are prevented from turning by means of set screws 13 which hold the spindles securely fixed in position in the members or brackets 12.

In the space between the opposed ends of the mandrel rods 10 and 11, there is arranged a pair of coil shaping tubes 14 and 15, respectively, with the mouth 16 of the tube 14 arranged directly opposite the end of the rod 10 and the mouth 17 of the tube 15 arranged directly opposite the end of the rod 11. It will be noted that these tubes 14 and 15 are arranged angularly relative to the rods 10 and 11 and converge toward the lower end thereof. Directly below these tubes 14 and 15 there is arranged preferably a curing and sizing tunnel 18 which is heated in any suitable manner and to any desired temperature. Above the tubes 14 and 15, there is arranged for reciprocal movement in a bracket 19, a pusher rod or ram 20 which is adapted to cooperate with a passageway 21 in the tunnel 18 to force the coiled filaments into and

through this passageway 21 to cure and size the same in a manner hereinafter to be described.

There is securely attached to each of the shafts 3 and 4 at the inner ends thereof, a circular member 23 which is adapted to rotate with the respective shafts. There is arranged in each of these circular members 23, as more clearly shown in FIG. 2, a radially disposed passageway 24 which extends from the periphery thereof inwardly to the respective shaft to which it is fixed. In the wall of each of the shafts 3 and 4, there is arranged at the inner end thereof, a passageway 25 which extends from the outer end of the shaft inwardly to the passageway 24 with which it communicates. There is carried by each of the circular members 23, an outwardly extending arm 26 having an eye 27 arranged in the outer end thereof.

Above the shafts 3 and 4, there is arranged in suitable bearings in the upper ends of the members or brackets 2a, a drive shaft 28 having a pair of gears 29 and 30 arranged thereon which mesh with gears 31 and 32 respectively, carried by the respective shafts 3 and 4 for driving the same. There is also arranged on this drive shaft 28 centrally thereof preferably an eccentric or cam 33 which is adapted to actuate the push rod or ram 20. At one end of this drive shaft 28 there is securely affixed thereto, a pulley 34 around which there is disposed a belt 35. This belt 35 may be driven by any suitable source of power but there is shown in the present instance a motor 36 having a pulley 37 around which the belt 35 is disposed guiding the same together with the drive shaft 28.

Having described the construction of the improved apparatus of the present invention, it functions in the following manner.

A spool S having filament F wrapped therearound is positioned on each of the shafts 3 and 4 with the shafts extending through the respective spools concentric therewith and with one end of each of the spools abutting the respective circular members 23 on the respective shafts as shown in FIG. 1 of the drawings. The filament F on each of the spools is then threaded up through the eyes 27 of the respective arms 26 and through the respective passageways 24 in the respective circular members 23 and out through the respective passageways 25 in the end of the respective shafts 3 and 4. The filament F is then wrapped around the respective stationary mandrel rods 10 and 11, as shown in FIG. 2, with the end of the respective filaments inserted through the respective tubes 14 and 15 and down through the passageway 21 in the curing tunnel 18. The apparatus is now in readiness for operation.

The motor 36 is then energized so that drive shaft 28 is rotated together with the shafts 3 and 4 through the action of the gears 29, 31, 30 and 32, as previously described. As the shafts 3 and 4 are rotated both the respective spools S and the circular members 23 carried thereby will also be rotated. It will be understood that the respective spools S not only rotate with the respective shafts 3 and 4 but also are rotatable relative thereto and to the respective members 23 and the filament guides arranged therewith. As these shafts and spools rotate, the filaments F will be pulled by the respective stationary mandrels from the respective spools due to the relative rotation thereof, through the passageways 24 and 25 and wrapped around the respective mandrel rods 10 and 11 so as to form the filaments F into coils C. As the convolutions of the filament build up on the mandrel rods 10 and 11, the coiled filaments move into the mouths 16 and 17 of the respective tubes 14 and 15 and pass down through the respective tubes to the exit or delivery end thereof, as shown in FIG. 1. It will be understood that the two coils as they emerge from the respective tubes 14 and 15 will be intermeshed at a point immediately above the curing tunnel 18. The pusher rod or ram 20 is then intermittently actuated by the eccentric or cam 33 so as to force the intermeshed coils down into and through the passageway 21 in the heating tunnel 18, wherein the coiled filaments

are cured and sized while being intermeshed with one another.

While I have shown and described an embodiment which my invention may assume in practice, it will be understood that this embodiment is merely for the purpose of illustration and description, and that other forms may be devised within the scope of my invention as defined in the appended claims.

What I claim as my invention is:

1. In apparatus for coiling and mating filaments and the like, a pair of oppositely disposed stationary mandrels arranged substantially in alignment with one another with their inner ends being spaced apart from one another, a pair of spools adapted to carry a supply of filament with one associated with each of said mandrels and concentric therewith, means for guiding the filament from each of said spools to the respective mandrels, means for rotating said spools about their respective axes, whereby the filament is wrapped around the respective mandrels so as to coil the same, means arranged adjacent each of said mandrels for receiving the coiled filaments for shaping the same, and means arranged adjacent said last mentioned means for curing and sizing the coiled filaments.

2. Apparatus as defined in claim 1, wherein the curing means for receiving the coiled filaments consists of a curing tunnel and includes a reciprocable rod positioned opposite thereto for forcing the coiled filaments into and through said tunnel.

3. Apparatus for coiling and mating filaments and the like, comprising a pair of oppositely disposed hollow rotatable shafts arranged in alignment with one another, means arranged on each of said shafts on which a supply of filament is adapted to be disposed, a stationary spindle arranged axially of each of said shafts and concentric therewith, a mandrel arranged in the end of each of said spindles and extending outwardly therefrom toward one another, a pair of coil shaping tubes arranged between the opposed ends of said mandrels with one arranged opposite each of said mandrels, the mouth of each said mandrel being positioned directly opposite the end of its respective mandrel, said tubes being arranged angularly relative to their respective mandrels and spindles in a converging manner so that the delivery end of the tubes are positioned directly opposite one another, curing means arranged directly opposite the delivery ends of said tubes for receiving said coiled filaments, and means for forcing the coiled filaments into said curing means as they are delivered from the inner ends of the respective tubes.

4. Apparatus as defined in claim 3, wherein the curing means for receiving the coiled filaments consists of a curing tunnel and includes a reciprocable rod positioned opposite thereto for forcing the coiled filaments into and through said tunnel.

5. Apparatus as defined in claim 3, wherein the means arranged on each of the shafts which is adapted to carry a supply of filament consists of a spool arranged on the respective shafts which is adapted to rotate therewith and also relative thereto and including means arranged adjacent the ends of the respective spools and shafts for guiding the filament from the spools to the respective mandrels.

6. Apparatus as defined in claim 3, wherein the means arranged on each of the shafts which is adapted to carry a supply of filament consists of a spool arranged on the respective shafts which is adapted to rotate therewith and also relative thereto, and including a circular member arranged adjacent the inner end of the respective spools and shafts, each of said circular members having a filament passageway arranged therein extending from the periphery thereof inwardly and radially to the respective shafts, each of said shafts having a filament passageway arranged therein which extends from the inner end thereof to the circular member and which communicates with the passageway in said circular member, and an outwardly extending arm carried by each of said circular members which is disposed substantially parallel to said

5

shafts, each of said arms having an eye arranged in the outer end thereof whereby the filament is guided from the respective spools through the respective eyes, through the passageways in said circular members and said shafts to the respective mandrels where the filaments are wrapped therearound as the respective shafts are rotated.

7. Apparatus for coiling and mating filaments and the like comprising a pair of oppositely disposed hollow rotatable shafts arranged in alignment with one another, a drive shaft arranged substantially parallel to said hollow rotatable shafts, a pair of gears securely arranged on said drive shaft with one meshing with a gear securely arranged in the outer ends of each of said hollow shafts, means for rotating said drive shaft, means arranged in each of said hollow shafts on which a supply of filament is adapted to be disposed, a stationary spindle arranged axially of each of said hollow shafts and concentric therewith, a mandrel arranged in the end of each of said spindles and extending outwardly therefrom toward one another, a pair of coil shaping tubes arranged between the opposed ends of said mandrels with one arranged opposite each of said mandrels, the mouth of each said tubes being positioned directly opposite the end of its respective mandrel, said tubes being arranged angularly relative to their respective mandrels and spindles in a converging manner so that the delivery end of the tubes are positioned directly opposite one another, curing means arranged directly opposite the delivery ends of said tubes for receiving said coiled filaments, and means for forcing the coiled filaments into said curing means as they are delivered from the delivery ends of the respective tubes.

8. Apparatus as defined in claim 7, wherein the curing means for receiving the coiled filaments consists of a curing tunnel and the forcing means includes a reciprocable rod positioned opposite thereto for forcing the coiled filaments into and through said tunnel.

9. Apparatus as defined in claim 7, wherein the means arranged on each of the shafts which is adapted to carry a supply of filament consists of a spool arranged on the respective shafts which is adapted to rotate therewith and also relative thereto and including means arranged on each of said shafts adjacent the ends of the respective spools for guiding the filament from the spools to the respective mandrels.

10. Apparatus as defined in claim 7, wherein the means arranged on each of the shafts which is adapted to carry a supply of filament consists of a spool arranged on the respective shafts which is adapted to rotate therewith and also relative thereto, and including a circular member arranged adjacent the inner end of the respective spools and shafts, each of said circular members having a filament passageway arranged therein extending from the periphery thereof inwardly and radially to the respective shafts, each of said shafts having a filament passageway arranged therein which extends from the inner end

6

thereof to the circular member and which communicates with the passageway in said circular member, and an outwardly extending arm carried by each of said circular members which is disposed substantially parallel to said shafts, each of said arms having an eye arranged in the outer end thereof whereby the filament is guided from the respective spools through the respective eyes, through the passageways in said circular members and said shafts to the respective mandrels where the filaments are wrapped therearound as the respective shafts are rotated.

11. The method of coiling and mating filaments and the like which comprises providing a pair of oppositely disposed stationary mandrels arranged substantially in alignment with one another, providing a pair of spools each having a supply of filament thereon, rotating the spools about their respective axes concentric with said mandrels so that the filament is drawn from the spools and wound around each of said mandrels so as to coil the filament, passing the coiled filaments into and through a pair of coil shaping tubes adjacent the opposed ends of the mandrels, interengaging the two coiled filaments, and finally curing the coiled filaments immediately after they are delivered from the respective tubes.

12. The method of coiling and mating filaments and the like which comprises providing a pair of oppositely disposed stationary mandrels arranged substantially in alignment with one another, providing a pair of spools each having a supply of filament thereon, rotating the spools about their respective axes concentric with said mandrels so that the filament is drawn from the spools and wound around each of said mandrels so as to coil the filament, passing the coiled filaments into and through a pair of coil shaping tubes adjacent the opposed ends of the mandrels, interengaging the two coiled filaments, and finally forcing the coiled filaments into and through a heating tunnel whereby the filaments are cured and sized immediately after they are delivered from the respective tubes.

13. The method of coiling a filament which comprises providing a stationary mandrel, providing a spool having a supply of filament thereon, rotating the spool about its axis concentric with said mandrel so that the filament is drawn from said spool and wound around said mandrel to coil the filament, passing the coiled filament into and through a coil shaping tube adjacent the end of said mandrel, and finally curing the coiled filament immediately after it is delivered from said tube.

References Cited in the file of this patent

UNITED STATES PATENTS

2,343,348	Wahl	Mar. 7, 1944
2,878,514	Nichols	Mar. 24, 1959
3,052,922	Wilcken	Sept. 11, 1962
3,053,288	Burbank	Sept. 11, 1962
3,071,917	Fisher	Jan. 8, 1963