

Nov. 17, 1953

A. H. MAYES

2,659,803

RADIANT HEATING SYSTEM

Filed Dec. 17, 1951

3 Sheets-Sheet 1

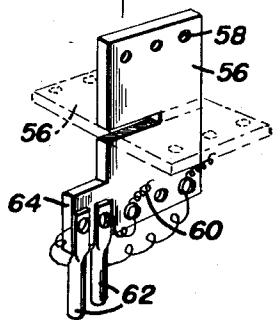
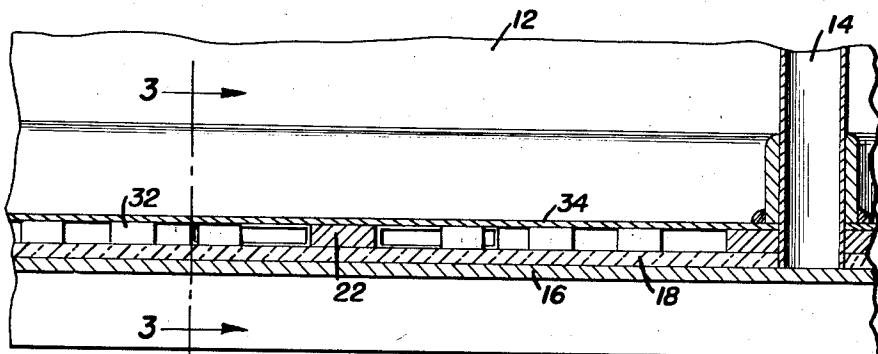
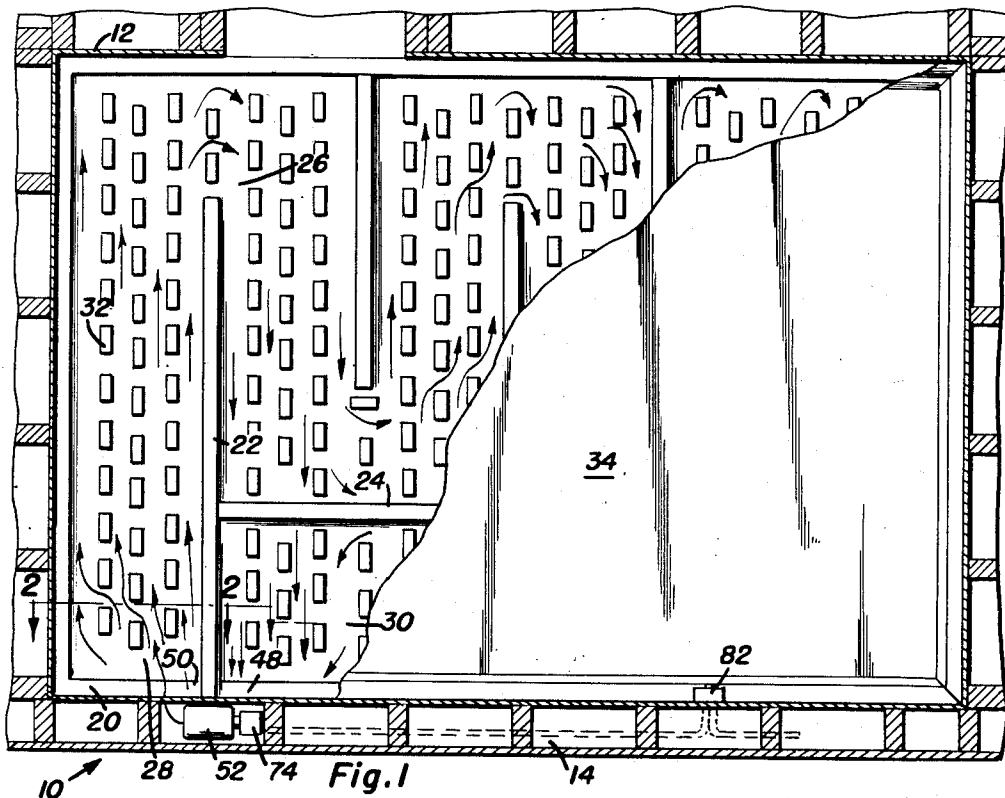

Fig. 2

Fig. 7

Albert H. Mayes  
INVENTOR.

BY *Almonce A. O'Brien*  
*and Harvey B. Jacobson*  
Attorneys

Nov. 17, 1953

A. H. MAYES

2,659,803

RADIANT HEATING SYSTEM

Filed Dec. 17, 1951

3 Sheets-Sheet 2

Fig. 3

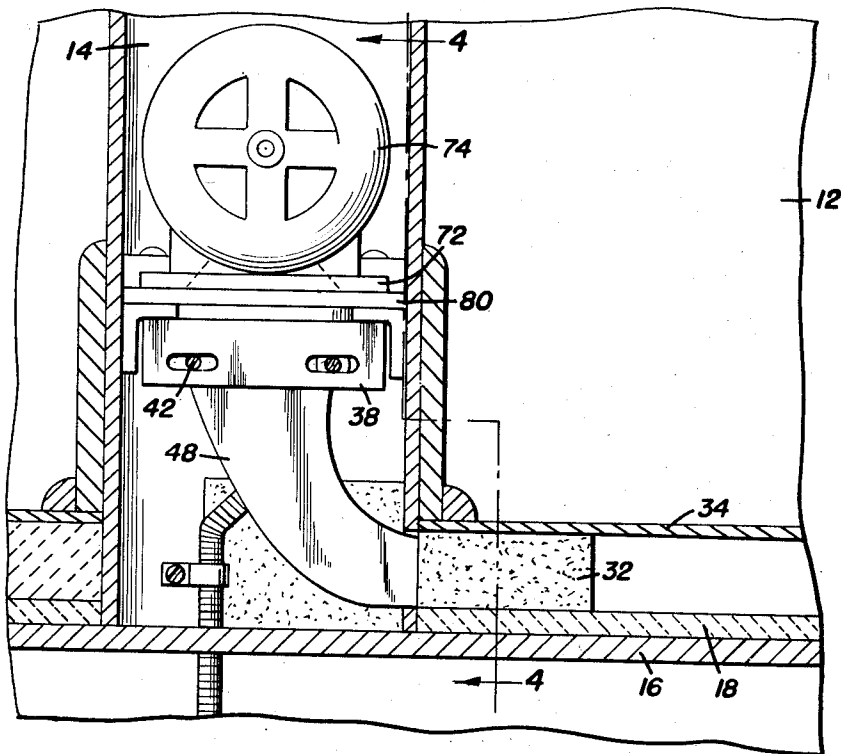
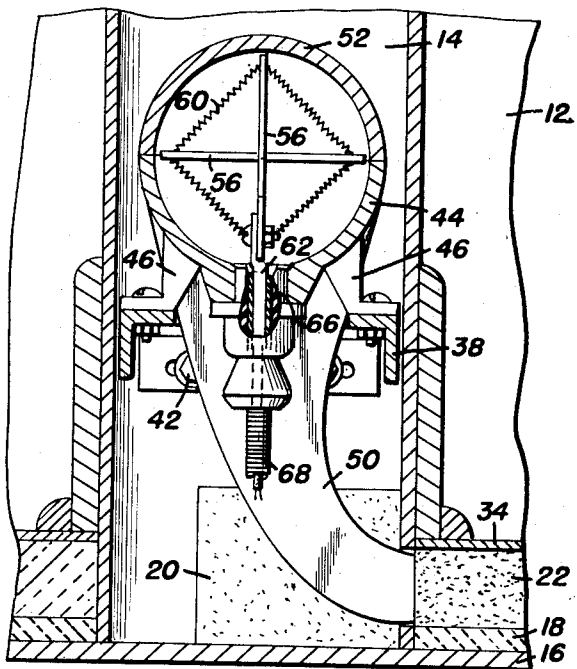

Fig. 5



Albert H. Mayes  
INVENTOR.

BY *Almonce A. Dixon*  
*and Harvey R. Jacobson*  
Attorneys

Nov. 17, 1953

A. H. MAYES

2,659,803

RADIANT HEATING SYSTEM

Filed Dec. 17, 1951

3 Sheets-Sheet 3

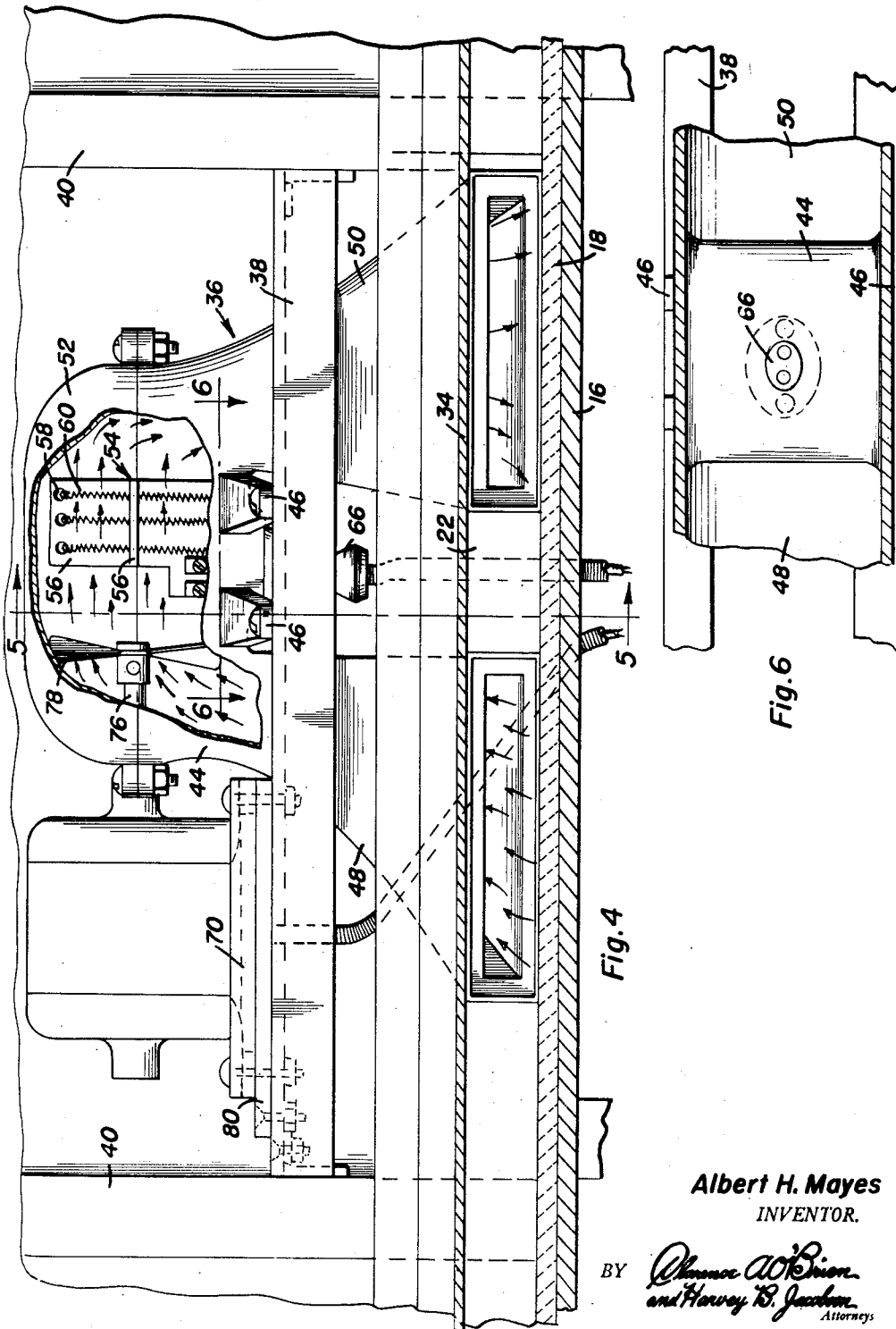

Fig. 4

Fig. 6

Albert H. Mayes  
INVENTOR.

BY *Alvanor W. Prinn*  
*and Harvey B. Jackson*  
Attorneys

# UNITED STATES PATENT OFFICE

2,659,803

## RADIANT HEATING SYSTEM

Albert H. Mayes, Endicott, N. Y.

Application December 17, 1951, Serial No. 262,028.

6 Claims. (Cl. 219-39)

1

This invention relates to new and useful improvements in heating systems and the primary object of the present invention is to provide an air conditioning system for building structures that is readily mountable on the existing floor of a building to produce substantially uniform heat for a room area.

Another important object of the present invention is to provide a radiant heat system including a tortuous passage member mounted on the existing floor of a room and covered by an aluminum flooring sheet, together with a hot air blower in communication with the passage for effectively heating the aluminum sheet as hot air is blown through the passage.

A further object of the present invention is to provide a radiant heat system including a novel and improved heat producing assembly and mount therefor that are readily mountable in a wall structure between a pair of adjacent joists and composed of parts that are quickly and readily assembled or disassembled in a convenient manner for inspection, cleaning and repair.

A still further aim of the present invention is to provide a heating system of the aforementioned character that is simple and practical in construction, strong and reliable in use, efficient and durable in operation, inexpensive to manufacture, install and operate, and otherwise well adapted for the purposes for which the same is intended.

Other objects and advantages reside in the details of construction and operation as more fully hereinafter described and claimed, reference being had to the accompanying drawings forming part hereof, wherein like numerals refer to like parts throughout, and in which:

Figure 1 is a horizontal sectional view of a building structure to show one room thereof and with the present invention mounted in the room and having a part of its flooring surface removed for the convenience of explanation;

Figure 2 is an enlarged fragmentary vertical sectional view taken substantially on the plane of section line 2-2 of Figure 1;

Figure 3 is an enlarged vertical sectional view taken substantially on the plane of section line 3-3 of Figure 2;

Figure 4 is a sectional view taken substantially on the plane of section line 4-4 of Figure 3;

Figure 5 is a vertical sectional view taken substantially on the plane of section line 5-5 of Figure 4;

Figure 6 is a horizontal sectional view taken

2

substantially on the plane of section line 6-6 of Figure 4; and

Figure 7 is a perspective view of the heating element used in the present invention.

5 Referring now to the drawings in detail, wherein for the purpose of illustration, there is disclosed a preferred embodiment of the present invention, the numeral 10 represents a building structure including a room 12 having the usual wall structures 14 and floor 16.

10 An asbestos sheet 18 completely covers the floor 16 and extends from wall to wall of the room 12. The sheet 18 supports marginal asbestos strips 20 on its upper face and these strips are 15 secured to sheet 18 by asbestos cement. Spaced parallel transverse strips 22, of asbestos, all also secured to the upper face of sheet 18 by asbestos cement with the strips extending from one side, being staggered relative to the strips extending 20 from the other side. Longitudinal strips 24, of asbestos, are secured to sheet 18 and extend between alternate strips 22, in such a manner as to define a tortuous passage 26 having an entrance 28 and an exit 30.

25 A plurality of baffle forming asbestos blocks 32 are secured to the sheet 18 by asbestos cement to slow the passage of air through passageway 26. The blocks 32 extend upwardly from the sheet 18 substantially the same amount as the strips 20, 22 and 24. A metallic sheet 34, preferably of 30 aluminum, extends over the sheet 18 and the blocks 32 and strips 20, 22 and 24. This metallic sheet, 34, forms a flooring and extends from wall to wall of the room 12.

35 Means is provided for drawing air from the exit 30 of passageway 26 and for directing air into and through the passageway by way of the entrance 28 of the passageway. This means 40 comprises a heat producing assembly 36 supported on a mount, the latter being in the form of an open substantially rectangular angle iron frame 38 whose ends are removably secured to the opposing faces of a pair of wall joists 40 45 by fasteners 42.

45 The lower section 44 of a housing member extends upwardly into the opening in frame 38 and is formed with laterally projecting ears 46 that are removably secured to the side portions of the frame 38. The bottom wall of housing forming section 44 is formed with an inlet spout 48 and an outlet spout 50 that extend into the exit 30 and entrance 28, respectively. The upper section 52 50 of the housing member is removably secured to section 44, whereby a heating element 54 may

3

be inserted into or removed from the housing member.

Heating element 54 comprises a pair of rectangular strips or plates 56 that are centrally transversely slotted to permit the plates to be engaged with one another. The ends of the plates 56 are provided with apertures 58 that receive heating coils 60 whose ends are connected to two conductive prongs 62 attached to an offset 64 of one of the plates.

The bottom wall of the section 44 is formed with a central opening in which a socket 66 is positioned to receive the prongs 62. An outlet cord 68 extends from socket 66 and to a suitable source of electric current.

A U-shaped motor mounting member 70 of channel shaped cross-section is removably secured to frame 38 and receives the flanged base plate 72 of an electric motor 74 whose armature shaft 76 extends into the housing member to support an impeller blade 78. The member 70 is preferably of two piece construction with its base portion 80 of resilient material to cushion the vibration of the motor.

In practical use of the present invention, the switch 82 to the motor and the heating element is positioned on a wall of the room 12. When the switch is moved to its circuit closing position, the heating element will be energized and the blade 78 will draw air from the exit of the passage and will direct air over the heating unit and through the outlet spout 50.

A bimetal member may be connected to the heating element or a suitable thermostat electrically connected therewith, whereby the room area may be heated to a predetermined temperature. Cooling coils may replace the heating unit and be connected to a refrigeration system to permit cooling of the room area in warm weather.

Having described the invention, what is claimed as new is:

1. In a building structure including a flooring and wall joists, an asbestos sheet covering the flooring, asbestos strips on the sheet and arranged to form a tortuous passage, a heating unit supported between a pair of joists and including an outlet in communication with one end of the passage and an inlet in communication with the other end of the passage, and a sheet metal floor covering the asbestos sheet.

2. The combination of claim 1 and a plurality of baffle forming asbestos blocks fixed in the passage.

3. In a building structure including a flooring and wall joists, an asbestos sheet covering the flooring, asbestos strips on the sheet and arranged to form a tortuous passage having an

4

entrance and an exit, a housing mounted between a pair of joists and having an outlet entering the entrance of the passage and an inlet in communication with the exit of the passage, a heating element in the housing, an impeller in the housing for directing air through said outlet, and a sheet metal floor covering the asbestos sheet.

4. In a building structure including a flooring and wall joists, an asbestos sheet covering the flooring, asbestos strips on the sheet and arranged to form a tortuous passage having an entrance and an exit, a housing mounted between a pair of joists and having an outlet entering the entrance of the passage and an inlet in communication with the exit of the passage, a heating element in the housing, an impeller in the housing for directing air through said outlet, baffle forming asbestos blocks in the passage, and an aluminum sheet covering the asbestos sheet.

5. The combination of claim 1 and a mount for the heating unit including a supporting frame having an opening therein in which the heating unit is mounted, a motor also mounted on the frame and having an armature shaft extending into the heating unit, and an impeller member on the shaft and within the heating unit.

6. In an air conditioning apparatus, a heat generating assembly and mount therefor comprising an open substantially rectangular frame, a housing member including an upper portion mounted in the opening in the frame, said housing member also including an inlet and an outlet extending downwardly from the frame in side by side relation, an electric heating element removably supported in the housing member, a motor mounted on the frame and having its shaft extending into the housing member, and an impeller member on the shaft and disposed in the housing member for drawing air into the housing member through the inlet and for directing air over the heating element and outwardly through the outlet.

ALBERT H. MAYES.

References Cited in the file of this patent  
UNITED STATES PATENTS

Number	Name	Date
1,520,241	Happe	Dec. 23, 1924
2,502,044	Isaacson	Mar. 28, 1950
2,568,278	Favot	Sept. 18, 1951
2,580,111	Mannist	Dec. 25, 1951

OTHER REFERENCES

Bobbio, "Heating & Ventilating," January 1951, pages 55-57. (Copy available in Library.)