

(19) World Intellectual Property Organization  
International Bureau



(43) International Publication Date  
24 December 2003 (24.12.2003)

PCT

(10) International Publication Number  
**WO 03/106909 A2**

- (51) International Patent Classification<sup>7</sup>: **F28F**
- (21) International Application Number: PCT/IB03/02594
- (22) International Filing Date: 6 June 2003 (06.06.2003)
- (25) Filing Language: Italian
- (26) Publication Language: English
- (30) Priority Data:  
MO2002A000163 13 June 2002 (13.06.2002) IT
- (71) Applicant (for all designated States except US): **WORGAS BRUCIATORI S.R.L.** [IT/IT]; Via A. Coppi, 17, I-41043 Formigine (IT).
- (72) Inventor; and
- (75) Inventor/Applicant (for US only): **GILIOLI, Massimo** [IT/IT]; Via Valeggio, 38, I-41042 Sassuolo (IT).
- (74) Agent: **CRUGNOLA, Pietro**; Luppi & Crugnola S.r.l., Viale Corassori, 54, I-41100 Modena (IT).
- (81) Designated States (national): AE, AG, AL, AM, AT, AU, AZ, BA, BB, BG, BR, BY, BZ, CA, CH, CN, CO, CR, CU, CZ, DE, DK, DM, DZ, EC, EE, ES, FI, GB, GD, GE, GH, GM, HR, HU, ID, IL, IN, IS, JP, KE, KG, KP, KR, KZ, LC, LK, LR, LS, LT, LU, LV, MA, MD, MG, MK, MN, MW, MX, MZ, NI, NO, NZ, OM, PH, PL, PT, RO, RU, SC, SD, SE, SG, SK, SL, TJ, TM, TN, TR, TT, TZ, UA, UG, US, UZ, VC, VN, YU, ZA, ZM, ZW.
- (84) Designated States (regional): ARIPO patent (GH, GM, KE, LS, MW, MZ, SD, SL, SZ, TZ, UG, ZM, ZW), Eurasian patent (AM, AZ, BY, KG, KZ, MD, RU, TJ, TM), European patent (AT, BE, BG, CH, CY, CZ, DE, DK, EE, ES, FI, FR, GB, GR, HU, IE, IT, LU, MC, NL, PT, RO, SE, SI, SK, TR), OAPI patent (BF, BJ, CF, CG, CI, CM, GA, GN, GQ, GW, ML, MR, NE, SN, TD, TG).

[Continued on next page]

(54) Title: HEAT EXCHANGER

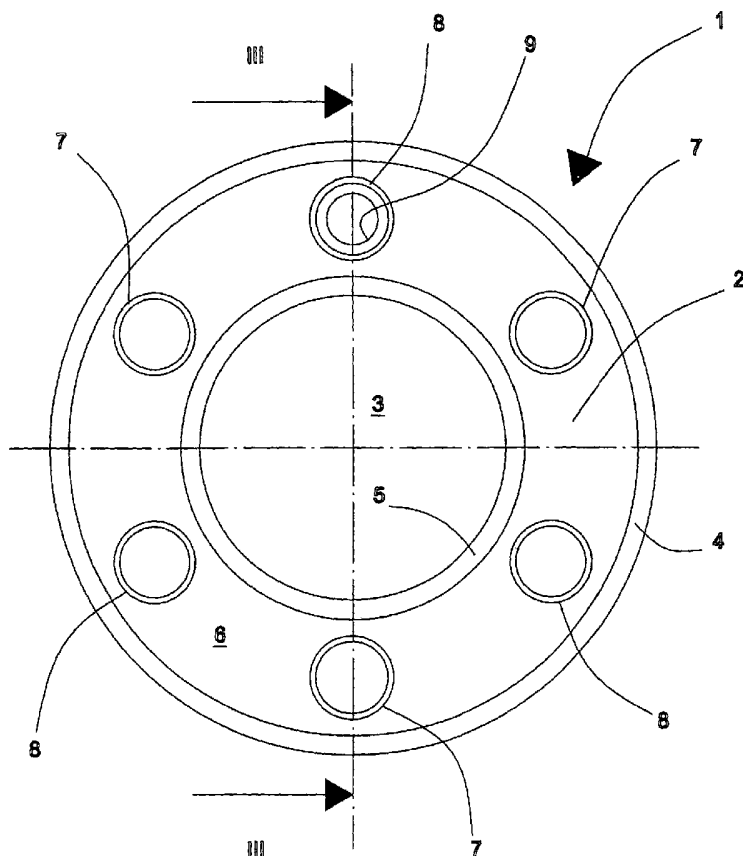

(57) Abstract: A heat exchanger (13; 13a; 13b; 13c; 13d; 13e) comprising a plurality of modular elements (10; 10a; 10b; 10c; 10d; 10e) that can be connected to one another serially or in parallel, that is equipped with an opening (3) wherein a burner (15) can be inserted, each modular element (10; 10a; 10b; 10c; 10d; 10e) comprises two half shells (1; 1a; 1b; 1c; 1d) between which a chamber (12) is defined for the circulation of a fluid, said chamber (12) being equipped with at least one opening (9; 9a; 24) for the entry of said fluid and with at least an opening (9; 9a; 24) for the exit of said fluid.



WO 03/106909 A2

**Declarations under Rule 4.17:**

- as to applicant's entitlement to apply for and be granted a patent (Rule 4.17(ii)) for the following designations AE, AG, AL, AM, AT, AU, AZ, BA, BB, BG, BR, BY, BZ, CA, CH, CN, CO, CR, CU, CZ, DE, DK, DM, DZ, EC, EE, ES, FI, GB, GD, GE, GH, GM, HR, HU, ID, IL, IN, IS, JP, KE, KG, KP, KR, KZ, LC, LK, LR, LS, LT, LU, LV, MA, MD, MG, MK, MN, MW, MX, MZ, NI, NO, NZ, OM, PH, PL, PT, RO, RU, SC, SD, SE, SG, SK, SL, TJ, TM, TN, TR, TT, TZ, UA, UG, UZ, VC, VN, YU, ZA, ZM, ZW, ARIPO patent (GH, GM, KE, LS, MW, MZ, SD, SL, SZ, TZ, UG, ZM, ZW), Eurasian patent (AM, AZ, BY, KG, KZ, MD, RU, TJ, TM), European patent (AT, BE, BG, CH, CY, CZ, DE, DK, EE, ES, FI, FR,

GB, GR, HU, IE, IT, LU, MC, NL, PT, RO, SE, SI, SK, TR), OAPI patent (BF, BJ, CF, CG, CI, CM, GA, GN, GQ, GW, ML, MR, NE, SN, TD, TG)

- as to the applicant's entitlement to claim the priority of the earlier application (Rule 4.17(iii)) for the following designation US

- of inventorship (Rule 4.17(iv)) for US only

**Published:**

- without international search report and to be republished upon receipt of that report

For two-letter codes and other abbreviations, refer to the "Guidance Notes on Codes and Abbreviations" appearing at the beginning of each regular issue of the PCT Gazette.

### Heat exchanger

This invention concerns a heat exchanger, in particular a gas/liquid heat exchanger for heating appliances consisting of a plurality of modular elements that can be connected to one another serially or in parallel, that are equipped with an opening wherein a burner can be inserted.

In the prior art, heat exchangers of the type mentioned above exist wherein each modular element consists of a tubular element wherein a liquid such as water is circulated; the tubular element is equipped at either end with an inlet and an outlet opening respectively and is wound in a configuration with the shape of a cylindrical helix comprising a set number of coils. Within said configuration with the shape of a cylindrical helix an opening with a circular shape is defined, through which a burner body can be inserted.

A heat exchanger of this type generally consists of a plurality of said modular elements, arranged one after the other along the axis of the cylindrical helix and inserted in a containing element, wherein the connections are made for connecting together the inlet and outlet openings of the tubular elements. The tubular elements can be serially connected together by connecting, by means of connection elements, the outlet opening of each element with the inlet opening of the next element or they can be parallel connected by connecting together the inlet and outlet openings of all the tubular elements. The containing element is also used to guide the fumes produced during burner operation between the coils of the tubular element to maximise heat exchange between said fumes and the liquid that is circulated within the tubular element.

Although said heat exchangers have a compact construction and have a good heat-exchange surface in relation to their external dimensions they are relatively expensive to make because of the operations of forming and bending the tubular

element that are required to configure the element in the shape of a cylindrical helix and possibly with cross-sections with a non-circular shape. Furthermore, the curve radius of the tubular element cannot descend below a minimum value to prevent the element's breaking during the bending phase. This makes it impossible to make heat exchangers with transversal dimensions that are below a given minimum value. Furthermore, in order not to make the connections between the different modular elements too complicated, each modular element normally comprises a plurality of coils, generally at least three. This means that the minimum increase in exchanger power, which can be obtained by adding a modular element, cannot fall below a minimum value, depending on the number of coils present in each modular element.

One aim of this invention is to provide a heat exchanger of the type mentioned above that is cheaper to make, that can have extremely compact transversal dimensions, that enables modular elements to be connected together in an extremely simple and rapid manner, wherein the minimum increase in the power of the exchanger, which can be obtained by adding a modular element, can be reduced to very low values, and which can be made by means of geometries that may even be different from a cylindrical geometry.

According to this invention, a heat exchanger is provided that comprises a plurality of modular elements that can be connected to one another serially or in parallel, that are equipped with an opening wherein a burner can be inserted, characterised in that each modular element comprises two half shells that are identical to one another, between which a chamber is defined for the circulation of a liquid, said chamber being equipped with at least one opening serving as an inlet for said liquid and at least one opening serving as an outlet for said liquid.

The half-shell structure of the modular elements enables the half shells themselves to be made by moulding using the same mould, thus significantly reducing production costs. Furthermore, the axial dimension and the transversal dimension of each modular element can be minimised, which enables extremely compact heat exchangers to be made with extremely reduced dimensions, where necessary. Lastly, the obtainable increase in power of the exchanger can be minimised by adding a modular element to the exchanger, which enables a wider power range to be obtained for the exchangers according to the invention.

According to a preferred embodiment of this invention, each half shell is equipped with connecting elements suitable for facilitating the reciprocal connection of said modular elements. Said connecting elements being preferably constituted of raised and recessed parts distributed on one face of the half shell intended to be coupled with a corresponding face of a respective half shell of an adjacent modular element. The raised and recessed parts of each half shell being dimensioned in such a way as to be coupled respectively with the recessed and raised parts of a half shell of a respective adjacent modular element.

Furthermore, the dimensions of said raised parts and of said recessed parts have been selected in such a way that when the modular elements are assembled together, between each modular element and an element adjacent to it there is a passage in a radial direction through which the fumes produced by said burner can pass to exchange heat with the liquid that circulates in said chambers.

The arrangement and the shape of the connecting elements enable very simple and rapid assembly of the modular elements to make up a heat exchanger.

Furthermore, the passages for the circulation of the fumes are obtained in an extremely simple manner during the phase of assembly of the modular elements of the exchanger.

According to a preferred embodiment of this invention, at least one of said connecting elements communicates with said chamber. This enables the chambers of the different modular elements to be connected together either serially or in parallel in a very simple manner, thereby eliminating the need for special connection elements.

10 In order that the invention may be clearly and completely disclosed, reference will now be made, by way of examples that do not limit the scope of the invention, to the accompanying drawings, wherein:

15 Fig. 1 is a front view of a half shell of a modular element of a heat exchanger according to the invention;

Fig. 2 is a view like the one in Fig. 1 of a first variation of a half shell of a modular element that can be coupled with the half shell in Fig. 1;

20 Fig. 3 is the cross-section III-III of the half shell in Fig. 1;

Fig. 4 is the cross-section IV-IV of the half shell in Fig. 2;

Fig. 5 is an axial cross-section of a modular element made up of two half shells that are coupled together;

25 Fig. 6 is a cross-section like the one in Fig. 5 of a first variation of a modular element that can be coupled with the modular element in Fig. 5;

Fig. 7 is an axial cross-section of an exchanger according to the invention, consisting of a plurality of modular elements that are serially connected together;

30 Fig. 8 is an axial cross-section of an exchanger according to the invention, consisting of a plurality of modular elements that are connected together in parallel;

Fig. 9 is a cross-section like those in Figs 3 and 4 of a second variation of a half shell of a modular element;

Fig. 10 is an axial cross-section of a second variation of a modular element that can be obtained by coupling two half shells like those in Fig. 9;

5 Fig. 11 is an axial cross-section of a heat exchanger that can be obtained by serially coupling together a plurality of modular elements like the one in Fig. 10;

Fig. 12 is an axial cross-section of a heat exchanger obtained by coupling together in parallel a plurality of modular elements like the one in Fig. 10;

10 Fig. 13 is a cross-section like those in Figs 3 and 4 regarding a third variation of a half shell of a modular element;

Fig. 14 is an axial cross-section of a third variation of a modular element that can be obtained by coupling together two  
15 half shells like the one in Fig. 13;

Fig. 15 is an axial cross-section of a heat exchanger that can be obtained by serially coupling together a plurality of modular elements like the one in Fig. 14;

Fig. 16 is an axial cross-section of a heat exchanger that can  
20 be obtained by coupling together in parallel a plurality of modular elements like the one in Fig. 14;

Figs 17 and 18 are axial cross-sections of a fourth and fifth variation of a modular element according to the invention;

Fig. 19, 20 and 21 are front views referring respectively to a  
25 fourth, fifth and sixth variation of a modular element according to the invention;

Fig. 22 is an axial cross-section of a heat exchanger according to the invention, inserted into a containing element that defines a route for the circulation of the fumes produced  
30 by a burner inserted in the central opening of the heat exchanger;

Fig. 23 is the cross-section XXIII-XXIII in Fig. 22.

A heat exchanger according to the invention consists of a plurality of modular elements that can be obtained by joining

together two half shells, each of which constitutes one half of the modular element, as will be explained below.

Fig. 1 shows a half shell 1 of a modular element of a heat exchanger according to the invention. Said half shell 1, having a substantially circular shape, comprises an annular strip 2 that surrounds a central hole 3, which is also substantially circular. One face of said annular strip 2 is equipped with an external edge 4 and with an internal edge 5, both of which are raised, that define an annular half chamber 6 between them. Along said annular strip 2, a plurality of raised parts 7 and depressions 8 is distributed at a preferably constant angle. At least one of said raised parts 7 or at least one of said depressions 8 is equipped with a through opening 9, 9a that communicates with said annular half chamber 6. Figs 1 and 3 show a half shell 1 wherein a through opening 9 that communicates with the annular half chamber 6 is made in one of the depressions 8. Figs 2 and 4 show, by contrast, a first variation 1a of a half shell according to the invention wherein a through opening 9a that communicates with the annular half chamber 6 is made in one of the raised parts 7. Fig. 5 shows a modular element 10 of a heat exchanger according to the invention, which is obtained by joining together two half shells 1. The modular element 10 that is thereby obtained has a central hole 11 that is defined by the central holes 3 of the two half shells 1 that make it up. Within the modular element 10 an annular chamber 12 is defined that is made up of the annular half chambers 6 of the two half shells 1.

The arrows F show, purely by way of example, the inlet and outlet in the modular element 10 of the fluid that circulates in a heat exchanger that can be made by using said modular elements 10. Fig. 6 shows another modular element 10a, that is similar the modular element 10, that is obtained by joining together two half shells 1a.

The modular elements 10 and 10a can be connected together by coupling the raised parts 7 of a half shell 1 of a first modular element 10 with the depressions 8 of a corresponding half shell 1a of a second modular element 10a and vice versa.

5 By coupling together a plurality of modular elements 10 and 10a a heat exchanger 13, 13a (Figs 7 and 8) is obtained with a substantially annular shape with a cylindrical central passage 14 wherein a burner can be inserted, as will be explained below.

10 Fig. 7 shows a heat exchanger 13 that is obtained by serially connecting the modular elements 10, 10a, together, i.e. by connecting the outlet of each modular element 10, 10a with the inlet of the next modular element 10, 10a. The arrows F1 show the route of the fluid inside the heat exchanger.

15 Fig. 8 shows a heat exchanger 13a that is obtained by connecting in parallel the modular elements 10, 10a, i.e. by connecting all the inlets and all the outlets of the modular elements 10, 10a. The arrows F2 show the route of the fluid inside the heat exchanger.

20 Fig. 9 shows a second variation 1b of a half shell according to the invention wherein only the raised parts 7 are present, in at least one of which a through opening 9a is made for the passage of the fluid.

Fig. 10 shows a modular element 10b that is obtained by  
25 joining two half shells 1b. The arrows F3 show, by way of example, the inlet and outlet of the fluid in the modular element 10b.

Fig. 11 shows a heat exchanger 13b that is obtained by serially connecting together a plurality of modular elements  
30 10b. The arrows F4 show the route of the fluid inside the heat exchanger 13b.

Fig. 12 shows a heat exchanger 13c obtained by connecting together in parallel a plurality of modular elements 10b. The

arrows F5 show the route of the fluid inside the heat exchanger 13c.

Fig. 13 shows a third variation 1c of a half shell according to the invention wherein only the depressions 8 are present, in at least one of which a through opening 9 is made for the passage of the fluid.

Fig. 14 shows a modular element 10c that is obtained by joining two half shells 1c. The arrows F6 show, by way of example, the inlet and the outlet of the fluid in the modular element 10b.

Fig. 15 shows a heat exchanger 13d that is obtained by serially connecting together a plurality of modular elements 10c. The arrows F7 show the route of the fluid inside the heat exchanger 13d.

Fig. 16 shows a heat exchanger 13e obtained by connecting together in parallel a plurality of modular elements 10b. The arrows F8 show the route of the fluid inside the heat exchanger 13e.

Fig. 17 shows a modular element 10d that is similar to the modular element 10a that has the internal edges 5a of the half shells clinched towards the inside of the annular chamber 12. This arrangement has the advantage of preventing the internal edges 5a of the half shells that make up the modular element 10d from being exposed to the high degree of heat generated by the fumes produced by the burner that is inserted in the heat exchanger, inasmuch as, following clinching, they are located inside the annular chamber 12 wherein the fluid of the exchanger, e.g. water, circulates, which is at a much lower temperature than the fumes produced by the burner. It is thus possible to avoid recourse to materials that are very resistant to temperature.

Fig. 18 shows a modular element 10e that is similar to the modular element 10d, from which it differs by the fact that it is the external edges 4a of the half shells that make up the

modular element 10e that are clinched in such a way as to be inside the annular chamber 12. It is obviously possible to also make a modular element wherein both the external edges 4 and the internal edges 5 of the half shells are clinched towards the inside of the annular chamber 12.

Fig. 19 shows a modular element 10f, wherein at least one of said raised parts 7a and at least one of said depressions 8a may have an elliptic or anyway oblong shape the dimensions of which are greater than those of the other raised parts 7 or depressions 8. An opening 9b, which is also elliptic in shape or at least oblong, for the entry of the fluid into the modular element 10f is made in at least one of said depressions 8a and an opening 9c with an elliptic or anyway oblong shape for the exit of the fluid in the modular element 10f is made in at least one of said raised parts 7a in such a way as to have a passage cross-section that is enlarged for the fluid at the inlet and outlet of the modular element 10f in order to reduce load losses.

Fig. 20 shows a further embodiment of a modular element 10g according to the invention, wherein the annular chamber 12 is equipped with a baffle 22 that forces fluid that enters the inlet opening 9 to travel through the annular chamber 12 in a single direction as far as the outlet opening 9a; in this case it is advantageous to make the outlet opening 9a at the end of the annular chamber 12 located in the baffle 22 part opposite the part where the inlet opening 9 is located.

This solution has the advantage of allowing greater circulation speed of the fluid in the modular elements 10g and therefore better heat exchange between said fluid and the fumes produced by the burner 15. Whilst coupling together the modular elements 10g to make a heat exchanger it is advantageous to coordinate the adjacent elements amongst themselves in such a way that the inlet openings 9 of each modular element 10g are all in the same part of the respective

baffle 22. This enables the fluid to travel in the same direction in all the modular elements 10g in such a way as to minimise load losses during the passage of the fluid from one modular element 10g to the next one.

5 Fig. 21 shows a yet further variation of a modular element 10h, having an approximately oval shape, with two diametrically opposite expansions 25 wherein, on each face of the modular element 10h a raised part 23 and a depression 23a are respectively created that have greater dimensions than the  
10 other raised parts 7 and depressions 8. This enables, e.g. in the raised part 23, an opening 24 to be made on the first face of the modular element 10h that has enlarged dimensions for the entry of the fluid into the modular element and, in the depression 23a on a second face of the modular element 10h  
15 opposite said first face, an opening 24a with enlarged dimensions for the exit of the fluid to be made. These two openings 24, 24a with enlarged dimensions are used to reduce the load losses in the fluid entering and exiting the modular element 10h.

20 Figs 22 and 23 show a heat exchanger 13 according to the invention coupled with a burner 15, inserted in the central passage 14 of the exchanger 13. The raised parts 7 and the depressions 8 of the modular elements 10, 10a of the exchanger 13 are dimensioned in such a way that during coupling of the  
25 modular elements 10, 10a, passages 16 for the fumes produced by the combustion of a fuel burnt in said burner 15 remain defined between adjacent modular elements 10, 10a.

The heat exchanger 13 is completed by a bulkhead 17 that closes the central passage 14 at the end opposite the end from  
30 which the burner 15 is inserted. The exchanger 13 with the burner 15 is inserted into a containing element 18 equipped with an opening 19 for inserting the burner 15 into the central passage 14, and with an outlet conduit 20 for conveying the fumes produced by the burner 15 outside the heat

exchanger. The bulkhead 17 means that the fumes produced by the burner 15 have to go through the passages 16 between the modular elements 10, 10a of the exchanger 13 before being conveyed to the outlet conduit 20 of the containing element 18, as indicated by the arrows F9, the aim of this being to improve the heat exchange between the fumes and the fluid that flows inside the heat exchanger 13.

The half shells 1-1c and therefore the modular elements 10-10h shown in the Figs have the shape of an annular strip with a substantially circular central hole. However, the form of the half shells 1-1c and of the modular elements 10-10h may also be elliptic, with an elliptic central hole; rectangular or square, with a rectangular or square central hole, or yet again polygonal, with a polygonal central hole.

To make the modular elements, the half shells can be connected together, e.g. by brazing, weld-brazing or welding. In the same way it is possible to make a connection between the different modular elements that make up the heat exchanger, in the zones affected by the passage of the fluid between one modular element and the modular elements adjacent to it. In the case of a heat exchanger made with the modular elements 10, 10a shown in Figs 5 and 6 the modular elements can be coupled through interference between the raised parts 7 and the depressions 8 of adjacent modular elements 10, 10a, by appropriately dimensioning said raised parts 7 and said depressions 8.

A heat exchanger according to the invention can also be made by assembling the half shells and the modular elements together by means of tie rods, with no welding between the adjacent half shells. In this case seal washers must be provided to place between the external 4 and internal 5 edges of the half shells of each modular element. The washers placed between the internal edges 5 of the half shells that are exposed to the high temperatures of the fumes produced by the

burner 15 must be made of a material with high resistance to heat. This need can be eliminated by using half shells that are provided with an internal edge 5 clinched towards the annular half chamber 6, as in the modular element 10d shown in  
5 Fig. 17.

In the practical embodiment the materials, dimensions and the implemented details may be different from those described but be technically equivalent, and still fall within the legal scope of this invention.

## CLAIMS

1. A heat exchanger (13; 13a; 13b; 13c; 13d; 13e) comprising a plurality of modular elements (10; 10a; 10b; 10c; 10d; 10e; 10f; 10g; 10h) that can be connected to one another serially or in parallel, equipped with an opening (3) wherein a burner (15) can be inserted, characterised in that each modular element (10; 10a; 10b; 10c; 10d; 10e; 10f; 10g; 10h) comprises two half shells (1; 1a; 1b; 1c) between which a chamber (12; 12a) is defined for the circulation of a fluid, said chamber (12; 12a) being equipped with at least an opening (9; 9a; 24) for the entry of said fluid and with at least an opening (9; 9a; 24a) for the exit of said fluid.
2. A heat exchanger (13; 13a; 13b; 13c; 13d; 13e) according to claim 1, wherein said half shells (1; 1a; 1b; 1c) are identical to one another.
3. A heat exchanger (13; 13a; 13b; 13c; 13d; 13e) according to claim 1, or 2, wherein each half shell (1; 1a; 1b; 1c) is equipped with connecting elements (7, 8; 7a, 8a; 23, 23a) suitable for facilitating the connection together of said modular elements (10; 10a; 10b; 10c; 10d; 10e; 10f; 10g; 10h).
4. A heat exchanger (13; 13a; 13b; 13c; 13d; 13e) according to claim 3, wherein said connecting elements (7, 8; 7a, 8a; 23, 23a) comprise a plurality of raised parts (7; 7a; 23) and/or a plurality of depressions (8; 8a; 23a) distributed on said half shell (1; 1a; 1b; 1c).
5. A heat exchanger (13; 13a; 13b; 13c; 13d; 13e) according to claim 4, wherein said raised parts (7; 7a; 23) and said depressions (8; 8a, 23a) are dimensioned in such a way as to enable coupling between raised parts (7; 7a; 23) and depressions (8; 8a; 23a) of a half shell (1; 1a; 1b; 1c) of a

modular element (10; 10a; 10b; 10c; 10d; 10e; 10f; 10g; 10h) respectively with corresponding depressions (8; 8a; 23a) and raised parts (7; 7a; 23) of a respective adjacent modular element (10; 10a; 10b; 10c; 10d; 10e; 10f; 10g; 10h).

5

6. A heat exchanger (13; 13a; 13b; 13c; 13d; 13e) according to claim 5, wherein said coupling is a coupling with interference.

10 7. A heat exchanger (13; 13a; 13b; 13c; 13d; 13e) according to any one of the previous claims, wherein on a face of said half shell (1; 1a; 1b; 1c) an external raised edge (4; 4a) peripherally delimiting the half shell and an internal raised edge (5; 5a) delimiting said opening (3) are provided, there  
15 being defined a half chamber (6) between said external edge (4; 4a) and said internal edge (5; 5a).

8. A heat exchanger (13; 13a; 13b; 13c; 13d; 13e) according to claim 7, wherein the half chambers (6) of each pair of half  
20 shells (1; 1a; 1b; 1c) that constitute a modular element (10; 10a; 10b; 10c; 10d; 10e; 10f; 10g; 10h) define, within the modular element, a chamber (12; 12a) for said fluid.

9. A heat exchanger (13; 13a; 13b; 13c; 13d; 13e) according to claim 8, wherein each half shell (1; 1a; 1b; 1c) is  
25 equipped with at least one through opening (9; 9a; 9b; 24; 24a).

10. A heat exchanger (13; 13a; 13b; 13c; 13d; 13e) according to claim 9, wherein at least one of said through openings (9;  
30 9a; 9b; 24; 24a) is made in one of said raised parts (7, 7a; 23) or in one of said depressions (8; 8a; 23a).

11. A heat exchanger (13; 13a; 13b; 13c; 13d; 13e) according to claim 9, or 10, wherein each modular element (10; 10a; 10b; 10c; 10d; 10e; 10f; 10g; 10h) is equipped with at least one inlet opening and at least one outlet opening, said inlet opening and said outlet opening being constituted by the through openings (9; 9a; 9b; 24; 24a) of the pair of half shells (1; 1a; 1b; 1c) that constitute the modular element (10; 10a; 10b; 10c; 10d; 10e; 10f; 10g; 10h).
- 10 12. A heat exchanger (13; 13a) according to any one of the claims from 4 to 11, wherein each of said half shells (1, 1a) comprises a plurality of said raised parts (7) alternating with a plurality of said depressions (8), said raised parts (7) and said depressions (8) being distributed at a substantially constant distance at said half chamber (6).
- 15 13. A heat exchanger (13; 13a) according to claim 12, comprising at least one first modular element (10) consisting of two half shells (1) in each one of which at least one of said through openings (9) is made in one of said depressions (8).
- 20 14. A heat exchanger (13; 13a) according to claim 12, or 13, comprising at least one second modular element (10a) consisting of two half shells (1) in each one of which at least one of said through openings (9a) is made in one of said raised parts (7).
- 25 15. A heat exchanger (13) according to claim 14, when dependent on claim 13, comprising at least one first modular element (10) and a second modular element (10a) that are serially connected together.
- 30

16. A heat exchanger (13a) according to claim 14, when dependent on claim 13, comprising at least one first modular element (10) and a second modular element (10a) connected together in parallel.

5

17. A heat exchanger (13b; 13c) according to any one of the claims from 4 to 11, wherein each half shell (1b) comprises a plurality of said raised parts (7) distributed at a substantially constant distance at said half chamber (6).

10

18. A heat exchanger (13b; 13c) according to claim 17, wherein at least one of said through openings (9a) is made in one of said raised parts (7).

15

19. A heat exchanger (13b) according to claim 17, comprising at least two modular elements (10b) that are serially connected together.

20. A heat exchanger (13c) according to claim 17, comprising at least two modular elements (10b) that are connected together in parallel.

20

21. A heat exchanger (13d; 13e) according to any one of the claims from 4 to 11, wherein each half shell (1c) comprises a plurality of said depressions (8) distributed at a substantially constant distance at said half chamber (6).

25

22. A heat exchanger (13d; 13e) according to claim 21, wherein at least one of said through openings (9) is made in one of said depressions (8).

30

23. A heat exchanger (13d) according to claim 22, comprising at least two modular elements (10c) that are serially connected together.
- 5 24. A heat exchanger (13e) according to claim 22, comprising at least two modular elements (10c) that are connected together in parallel .
- 10 25. A heat exchanger (13; 13a; 13b; 13c; 13d; 13e), according to any one of the claims from 4 to 20, wherein in each modular element (10f) at least one of said raised parts (7a) has a substantially elliptic shape, or an anyway oblong shape.
- 15 26. A heat exchanger (13; 13a; 13b; 13c; 13d; 13e), according to any one of the claims from 4 to 16 and from 21 to 24, wherein in each modular element (10f) at least one of said depressions (8a) has a substantially elliptic shape, or an anyway oblong shape.
- 20 27. A heat exchanger (13; 13a; 13b; 13c; 13d; 13e), according to claim 25, or 26, wherein in at least one of said raised parts (7a) with an elliptic or anyway oblong shape, or in at least one of said depressions (8a) with an elliptic or anyway oblong shape a through opening (9b; 9c) is made, which also
- 25 has an elliptic or anyway oblong shape.
28. A heat exchanger (13; 13a; 13b; 13c; 13d; 13e), according to any one of the claims from 7 to 27, comprising at least one modular element (10g) wherein said chamber (12) is equipped
- 30 with a dividing baffle (22).
29. A heat exchanger according to claim 28, comprising a plurality of said modular elements (10g) arranged in such a way that the inlet openings (9) of each modular element (10g)

are all on the same part of the respective dividing baffle (22).

5 30. A heat exchanger (13; 13a; 13b; 13c; 13d; 13e), according to any one of the previous claims, comprising at least one modular element (10h) that has an approximately oval shape, with two diametrically opposite expansions (25).

10 31. A heat exchanger (13; 13a; 13b; 13c; 13d; 13e), according to claim 30, wherein respective raised parts (23) and depressions (24) that have enlarged dimensions than the other respective raised parts (7) and depressions (8) are made in said expansions (25).

15 32. A heat exchanger (13; 13a; 13b; 13c; 13d; 13e), according to claim 31, wherein a through opening (24) of enlarged dimensions for the entry of said fluid into said modular element (10h) is made in one of said raised parts (23) or in one of said depressions (24).

20 33. A heat exchanger (13; 13a; 13b; 13c; 13d; 13e), according to claim 31, or 32, wherein a through opening (24a) of enlarged dimensions for the exit of said fluid from the modular element (10h) is made in one of said raised parts (23) or in one of said depressions (24).

30 34. A heat exchanger (13; 13a; 13b; 13c; 13d; 13e), according to any one of the previous claims, wherein between the adjacent modular elements (10; 10a; 10b; 10c; 10d; 10e; 10f; 10g; 10h) passages (16) are defined through which the fumes produced by said burner (15) can pass.

35. A heat exchanger (13; 13a; 13b; 13c; 13d; 13e), according to any one of the previous claims, furthermore comprising a

containing element (18) that encloses said modular elements (10; 10a; 10b; 10c; 10d; 10e; 10f; 10g; 10h) and is equipped with an inlet opening (19) to insert said burner (15) and with an outlet opening (20) for evacuating the fumes produced by  
5 said burner.

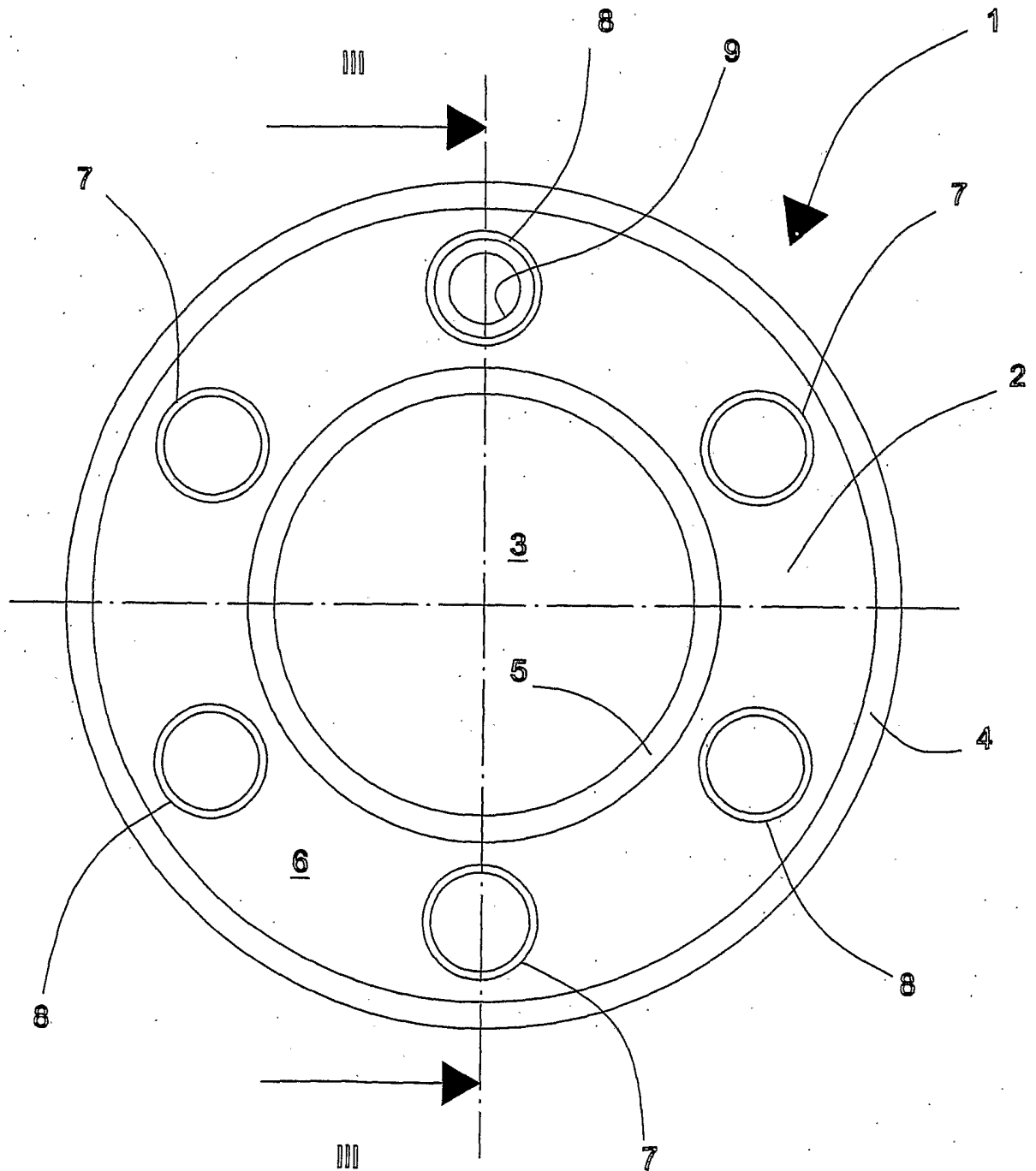

Fig. 1

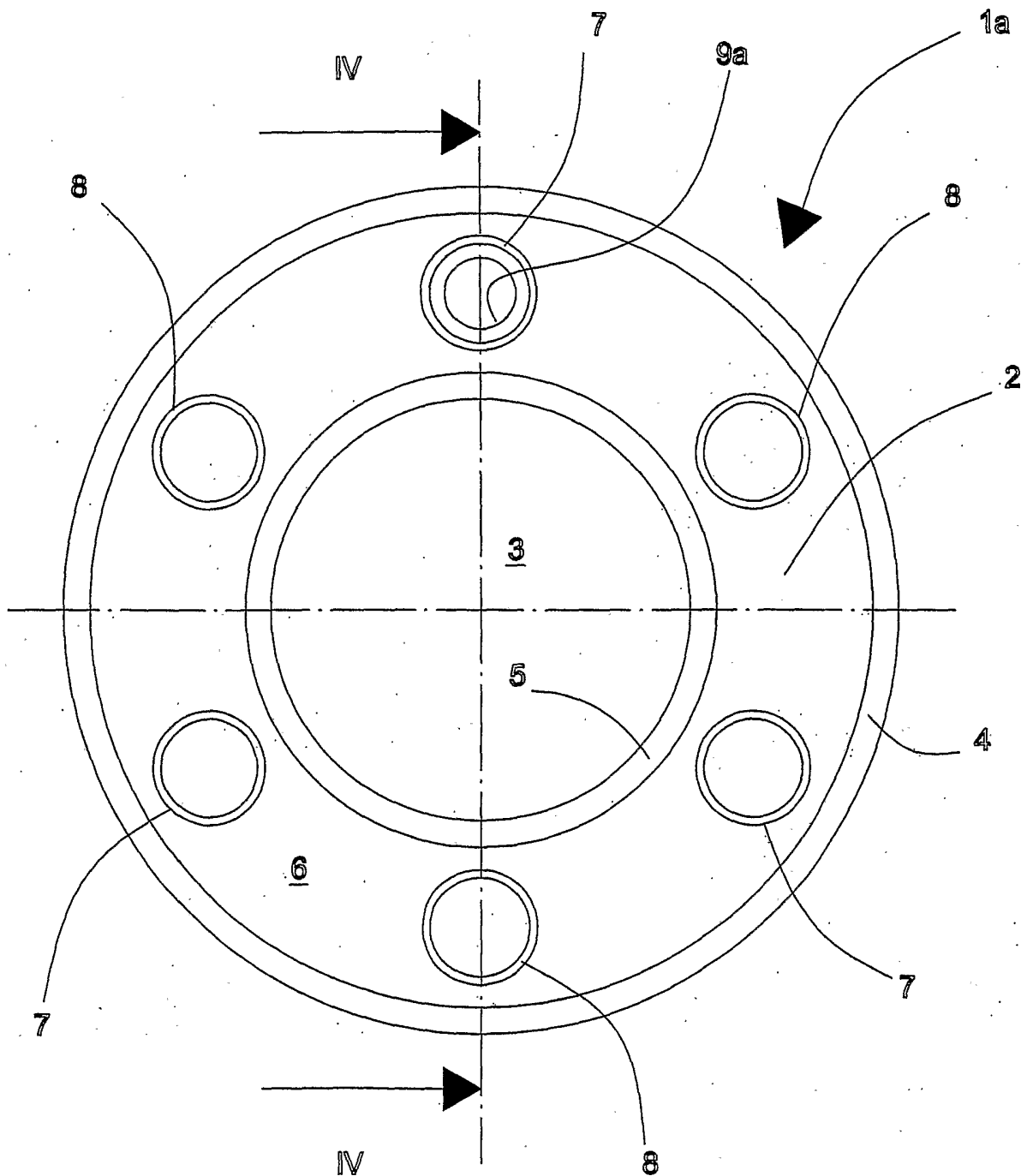

Fig. 2

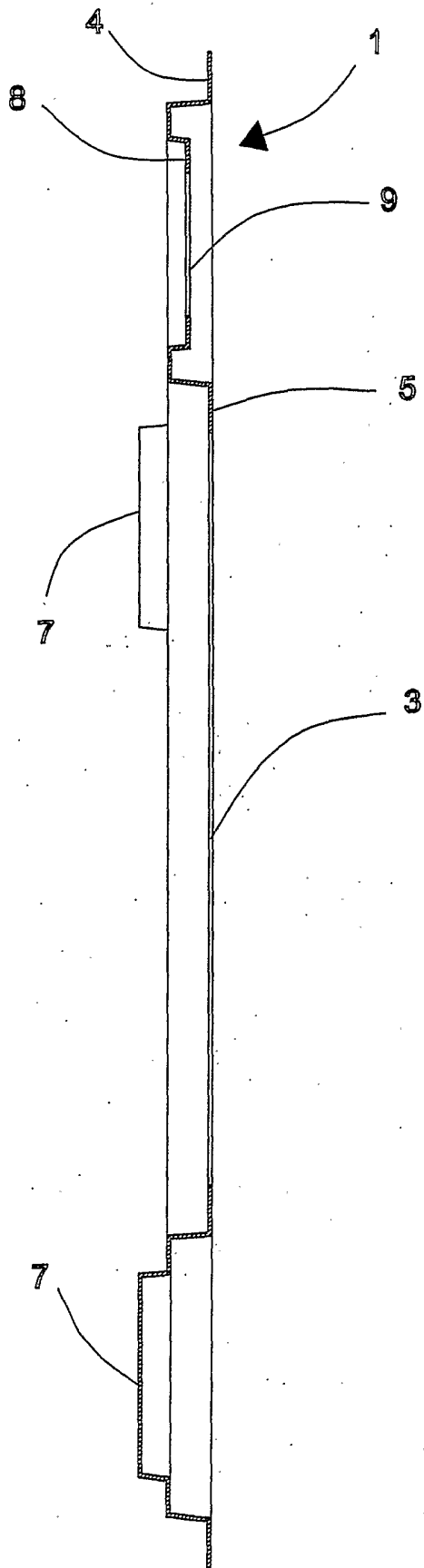

Fig. 3

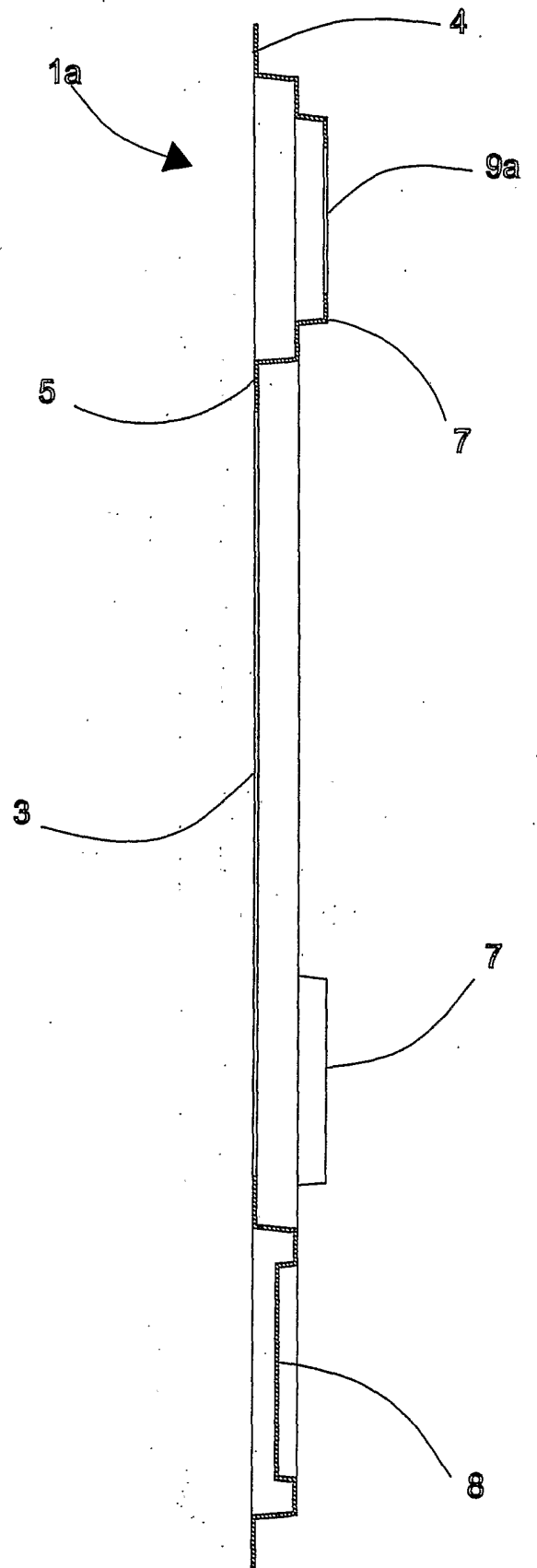

Fig. 4

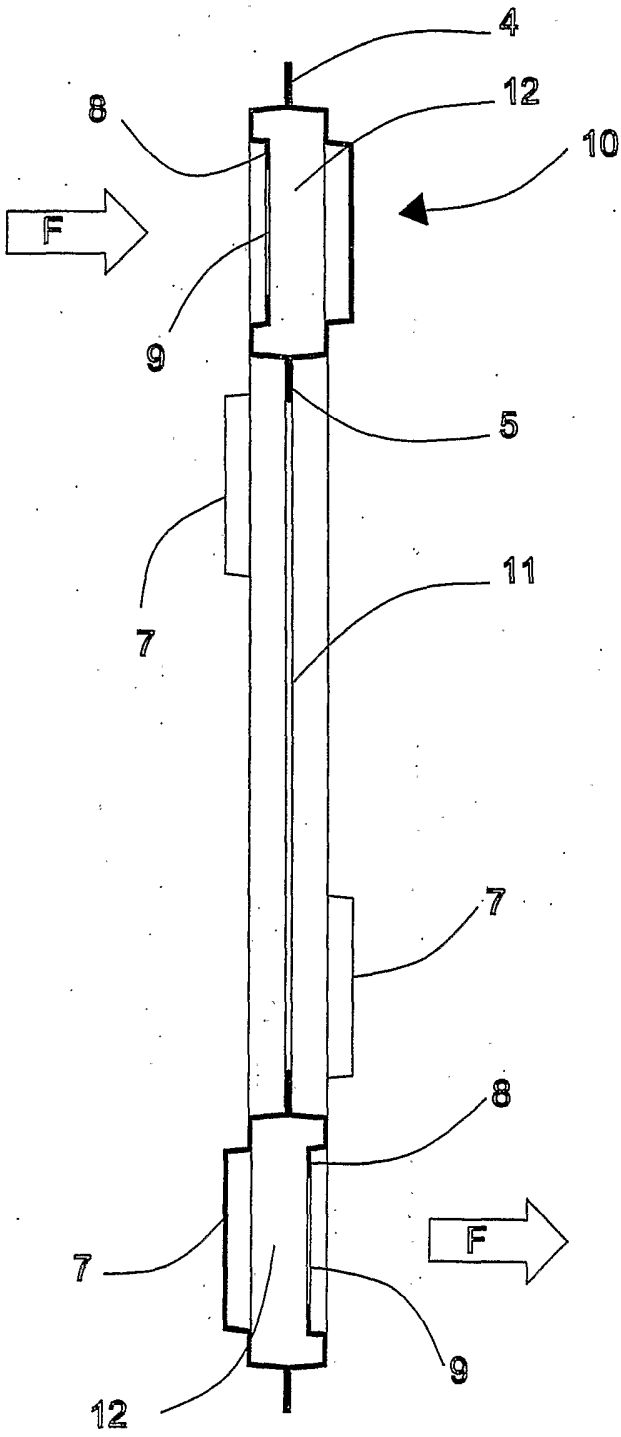

Fig. 5

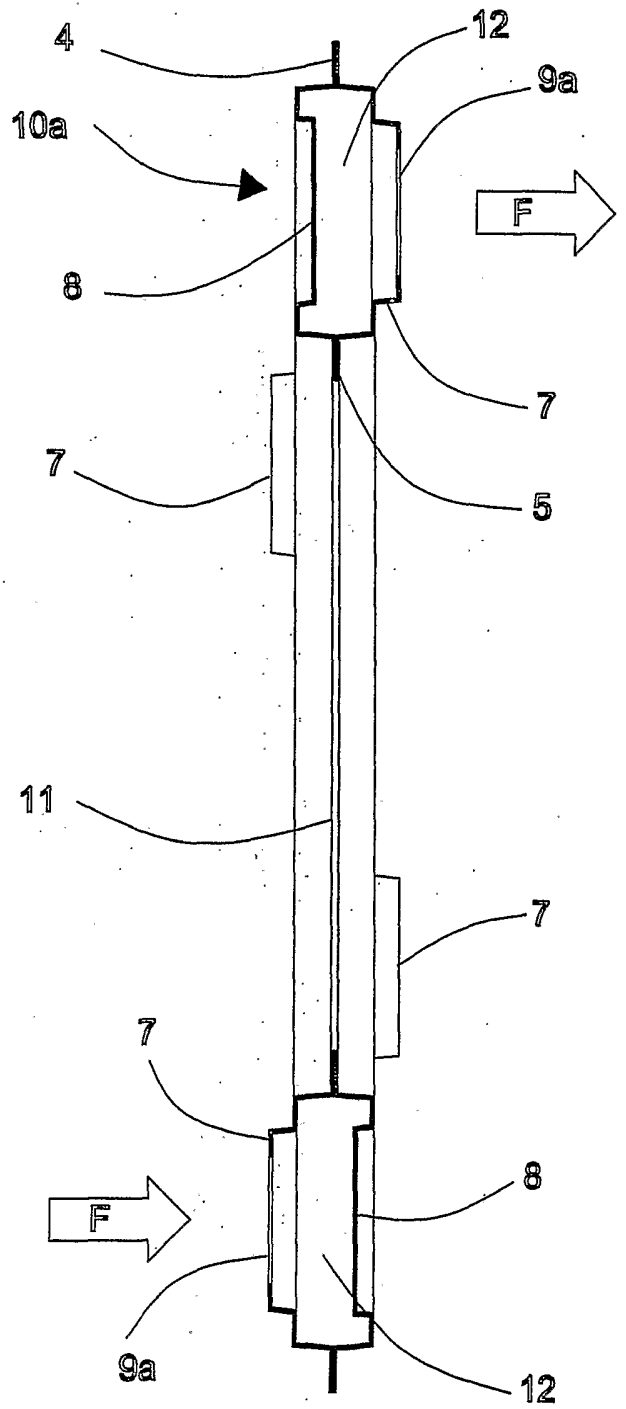

Fig. 6

5/18

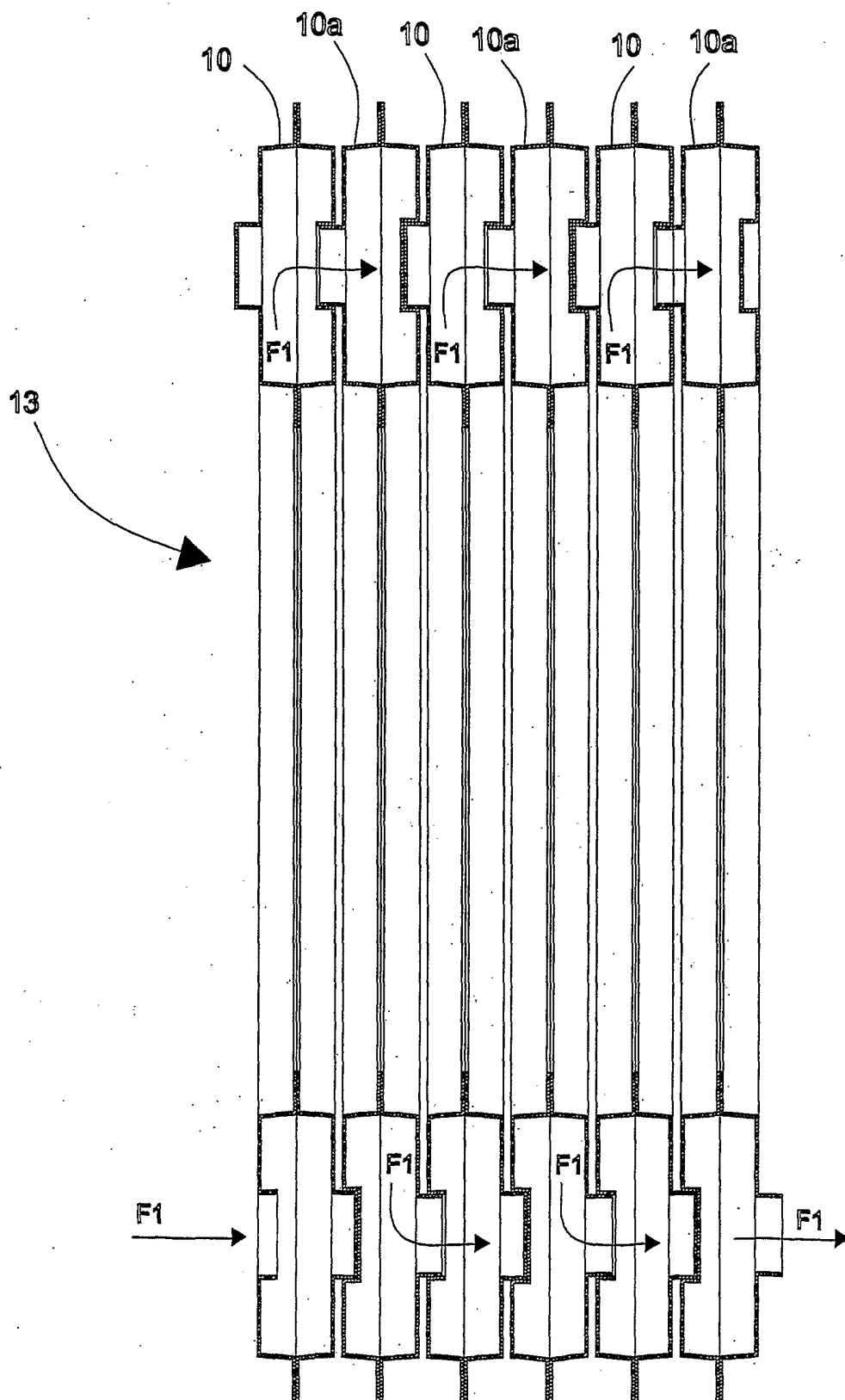

Fig. 7

6/18

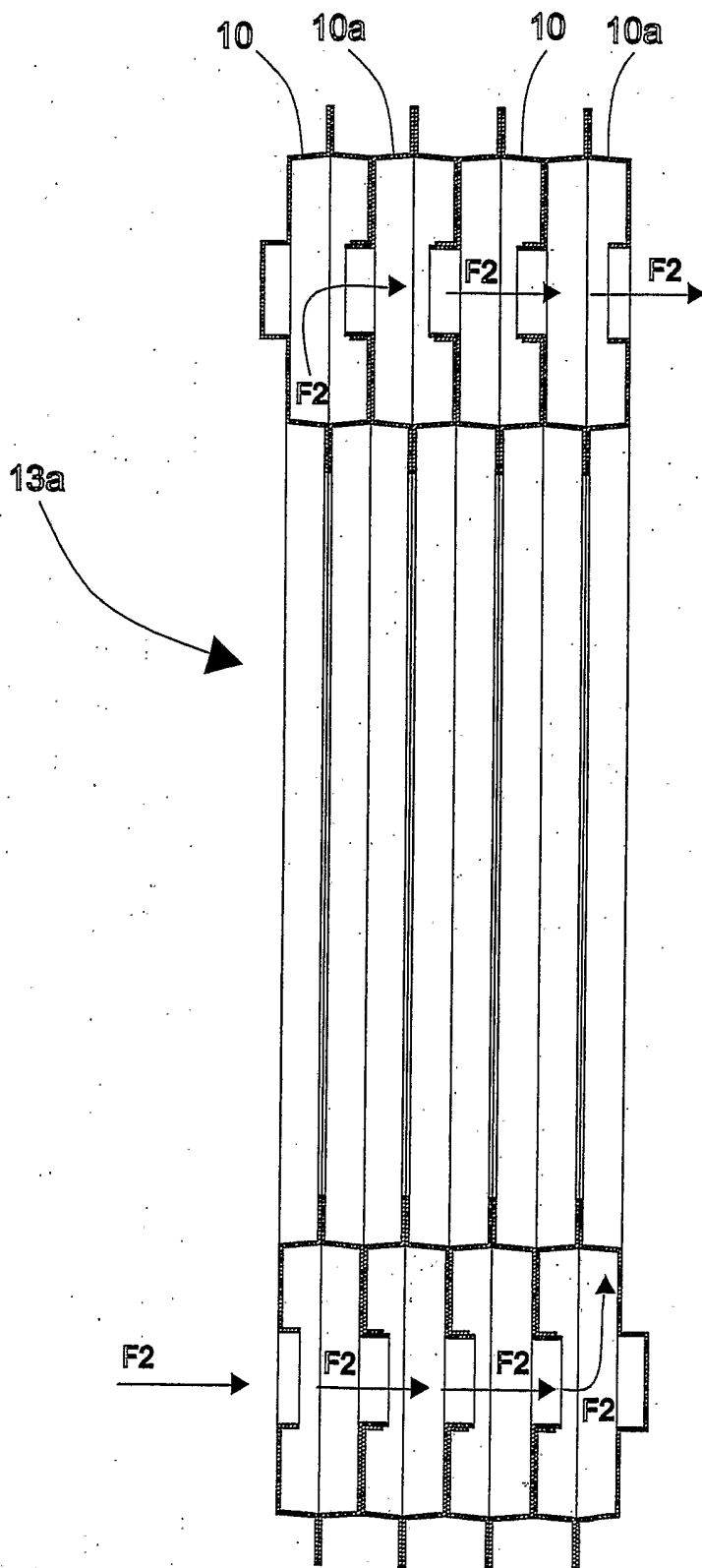

Fig. 8

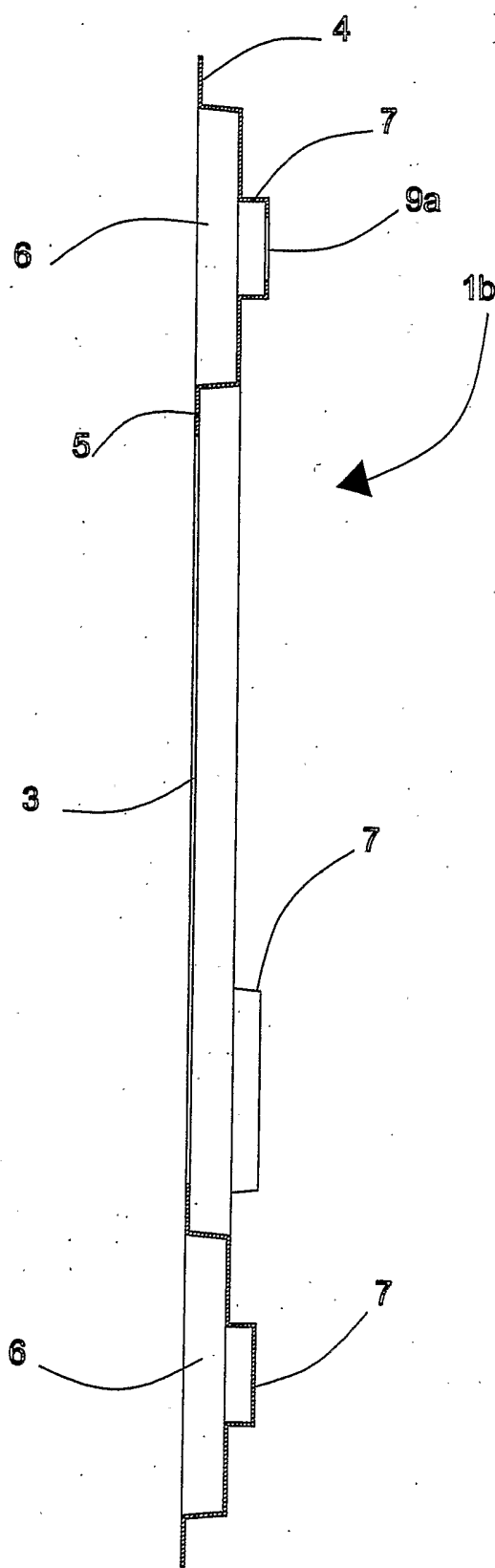

Fig. 9

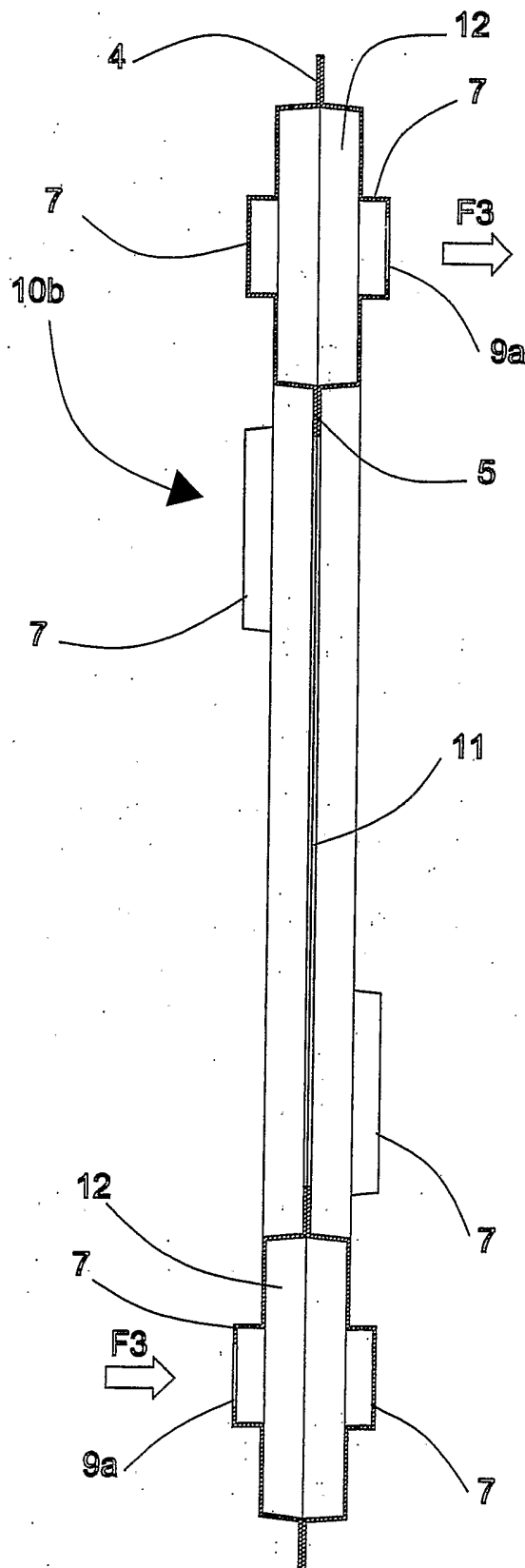

Fig. 10

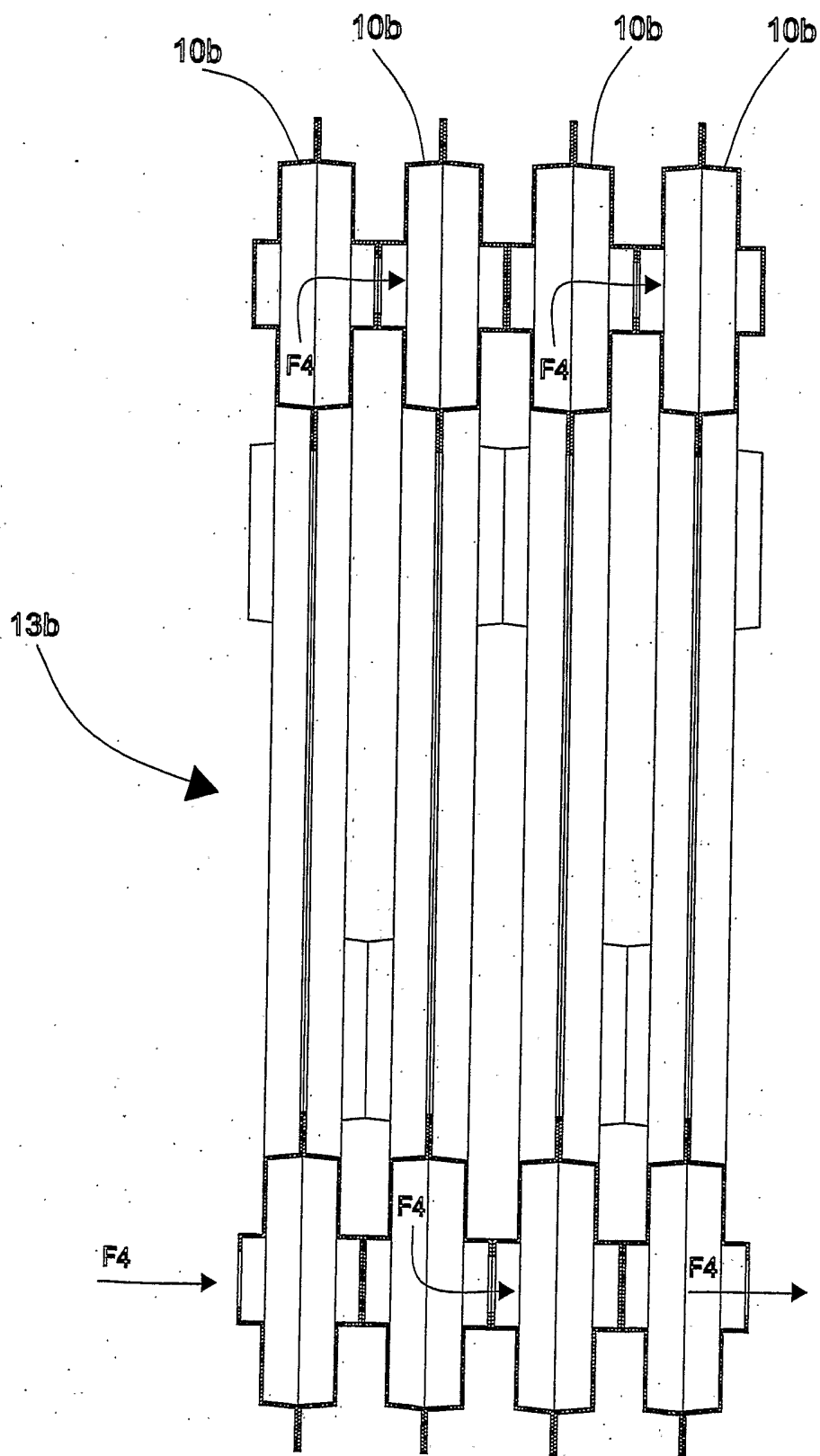

Fig. 11

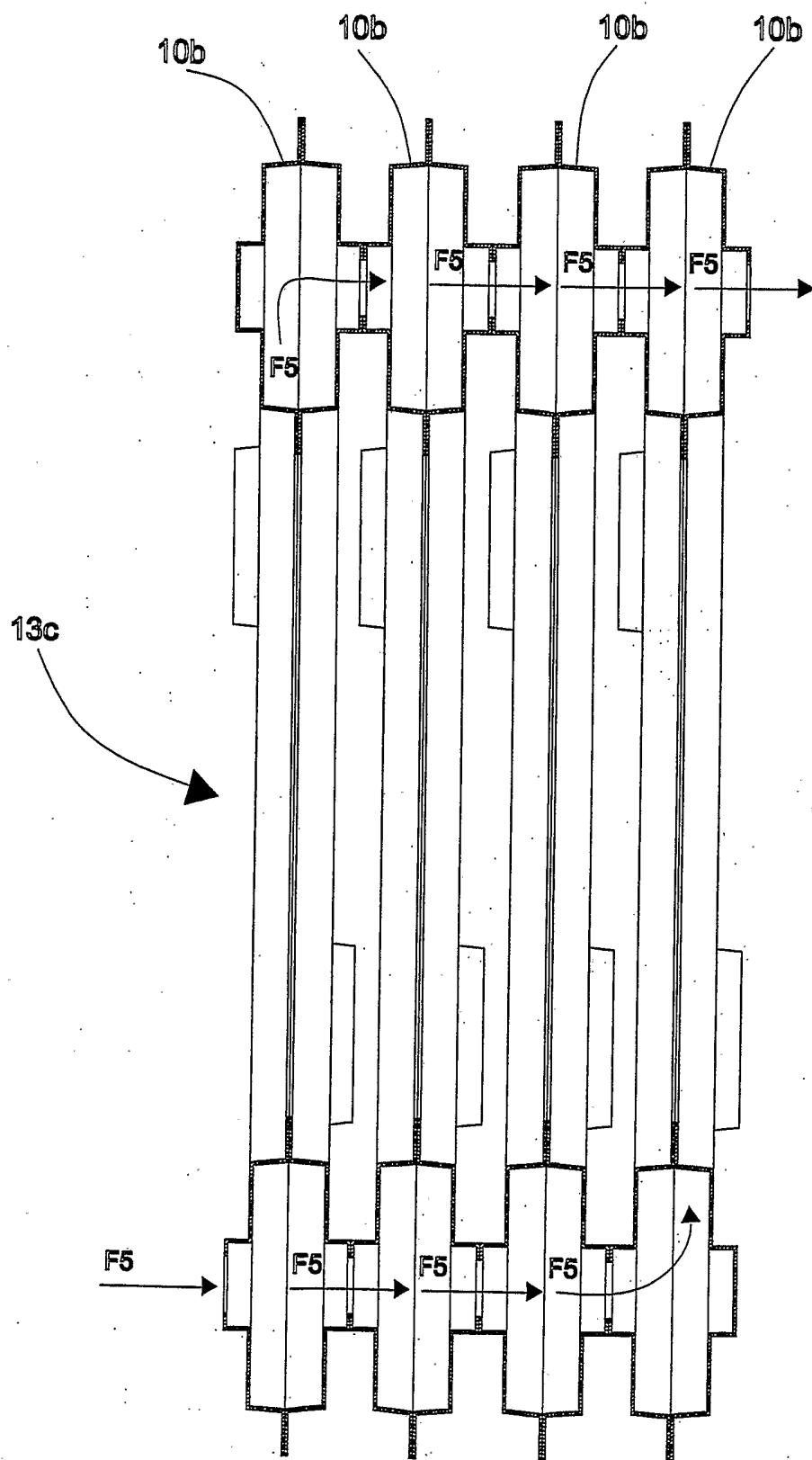

Fig. 12

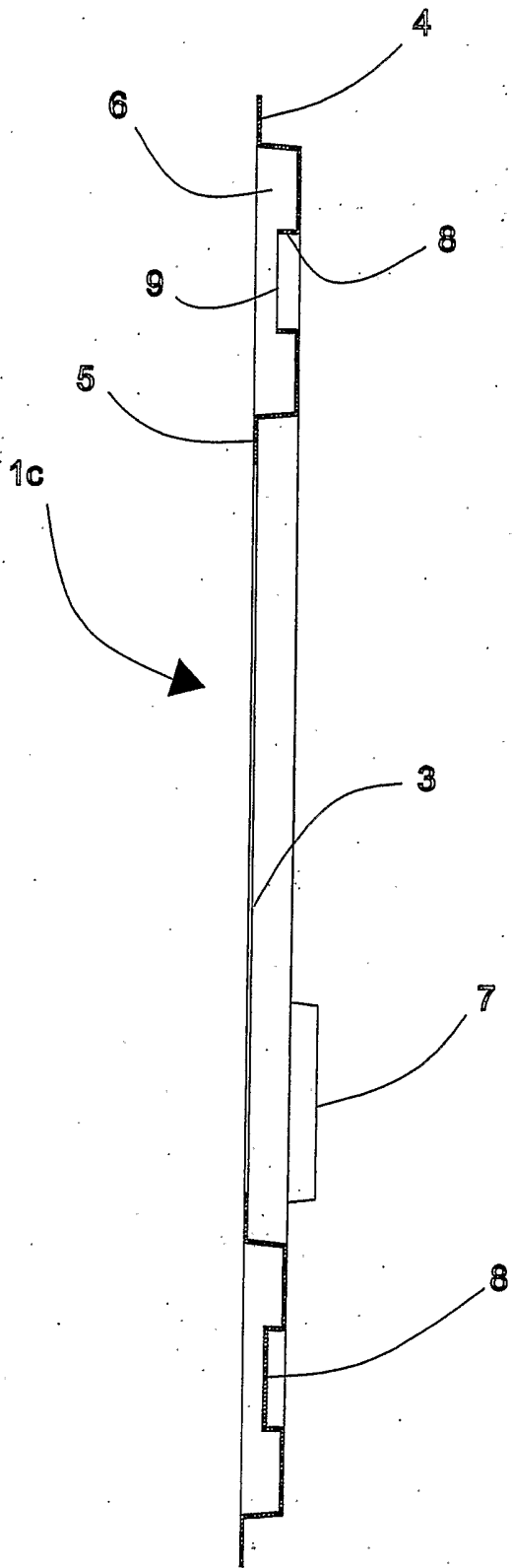

Fig. 13

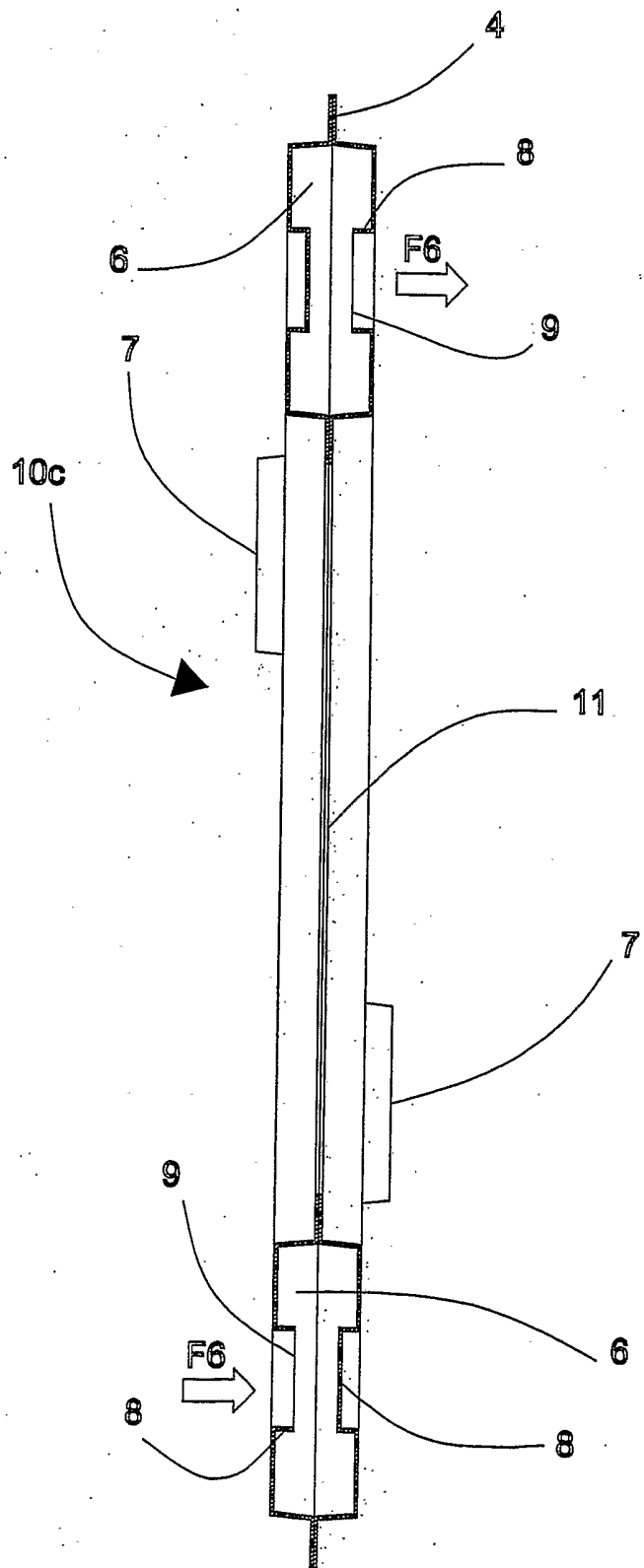

Fig. 14

11/18

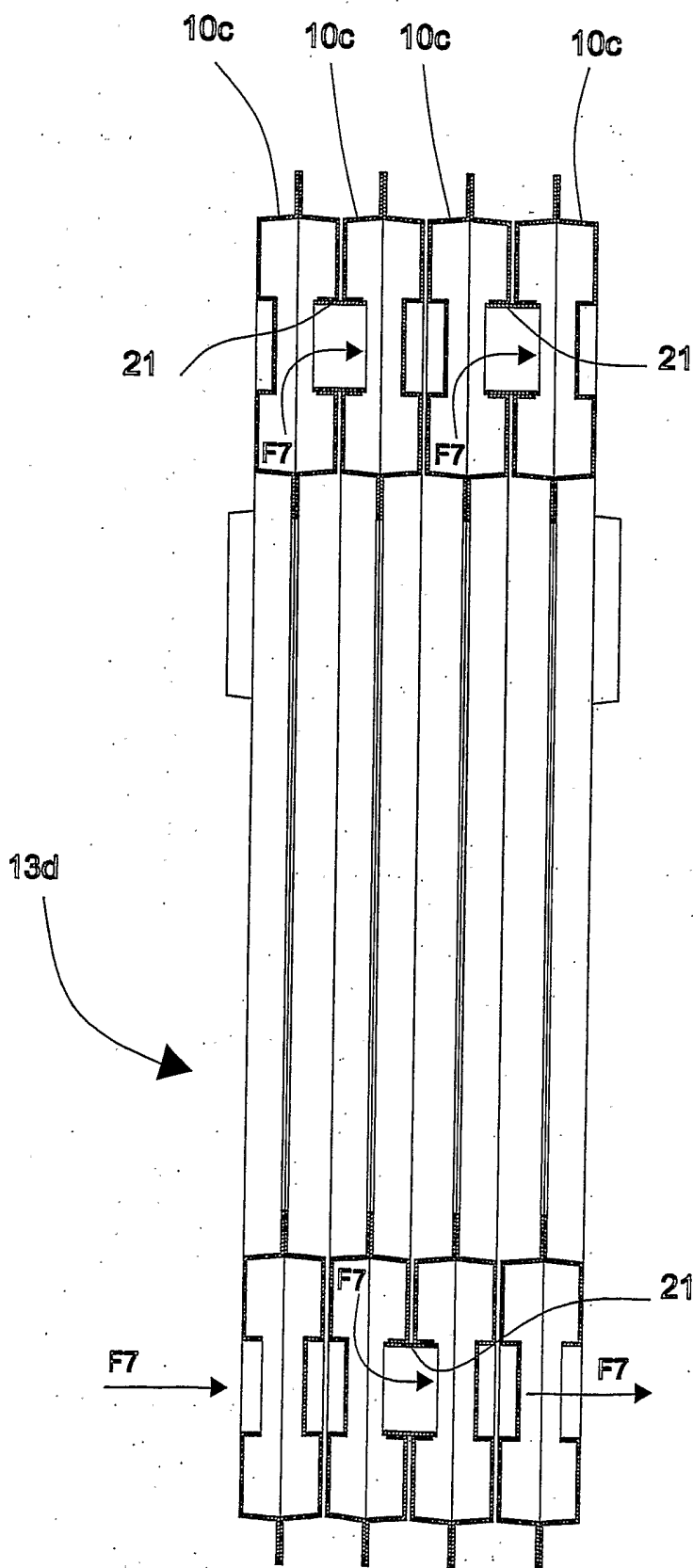

Fig. 15

12/18

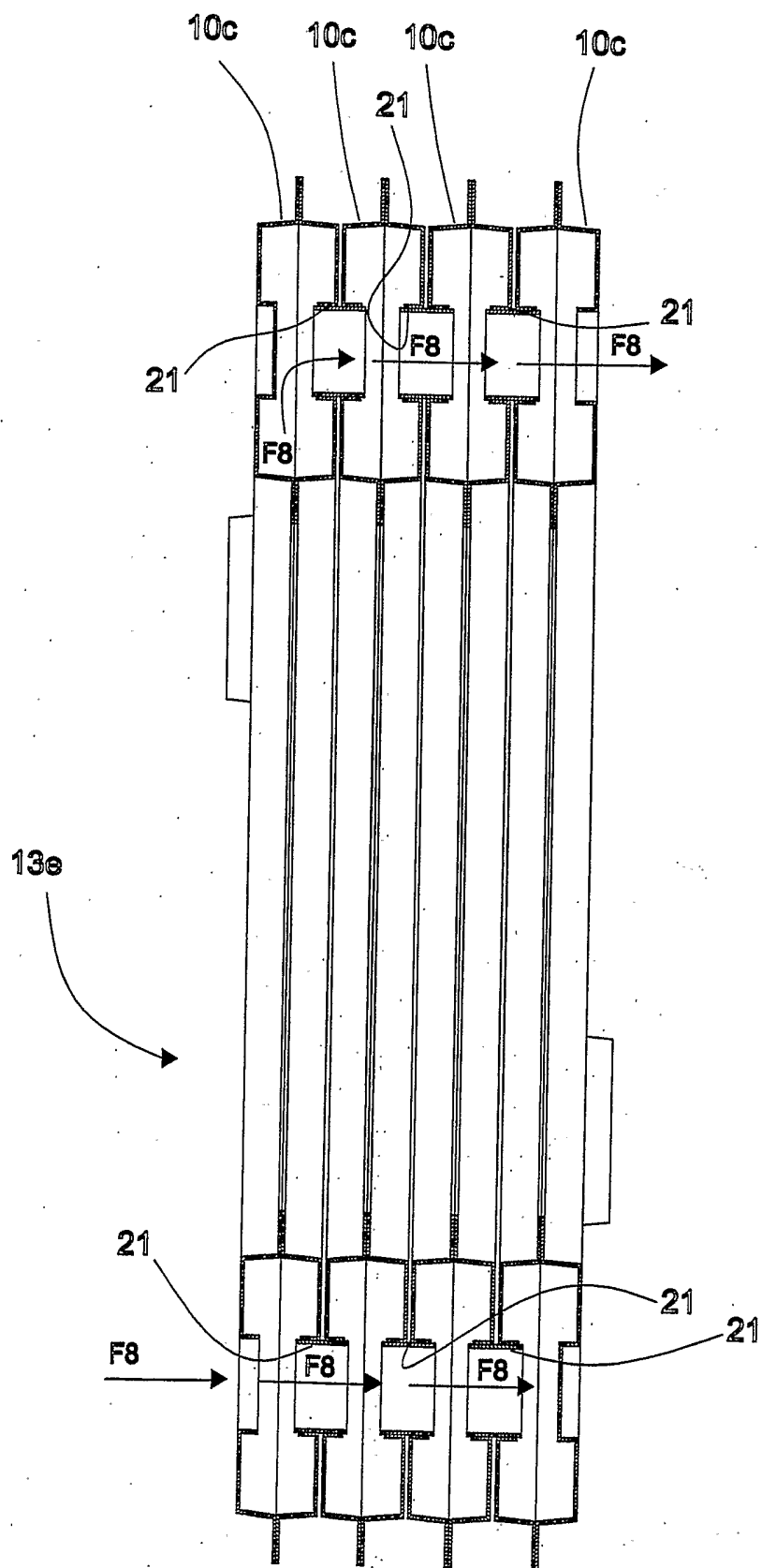

Fig. 16

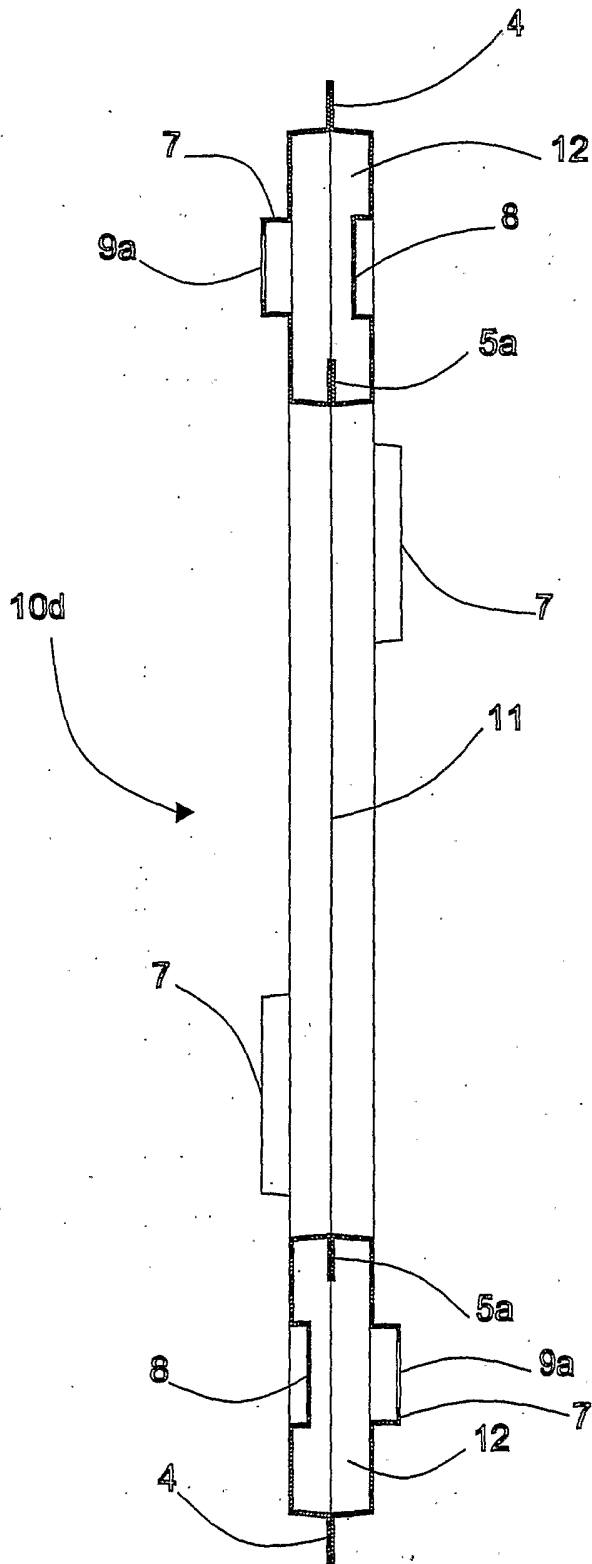

Fig. 17

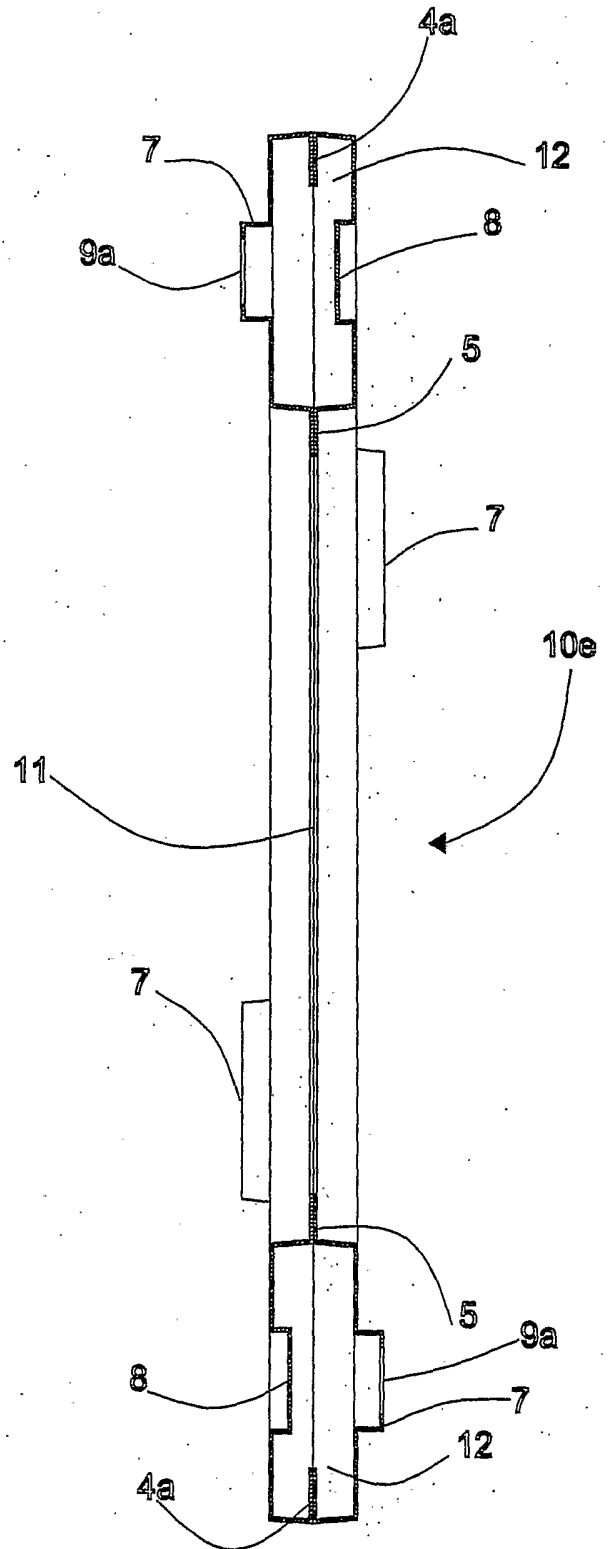

Fig. 18

14/18

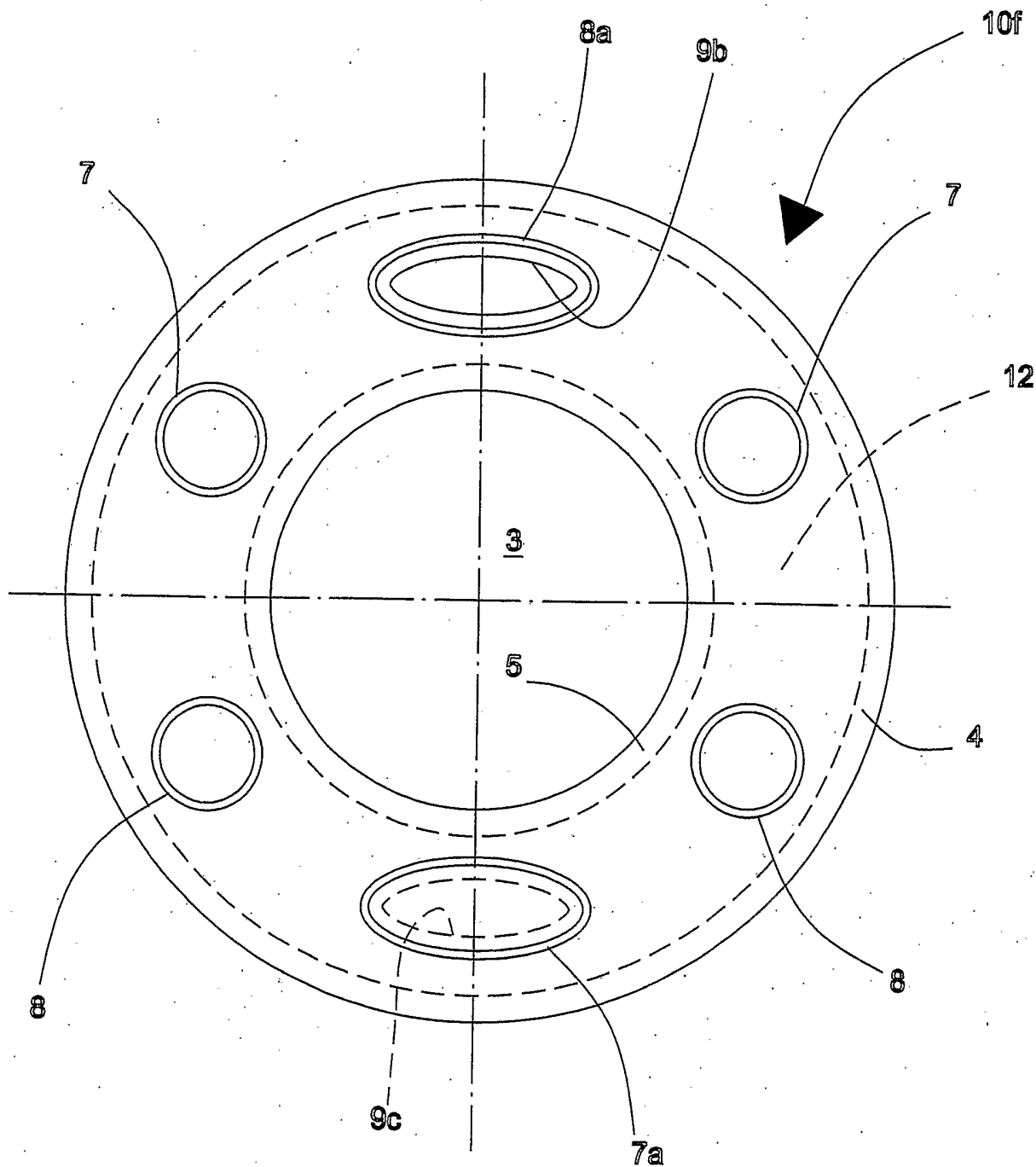

Fig. 19

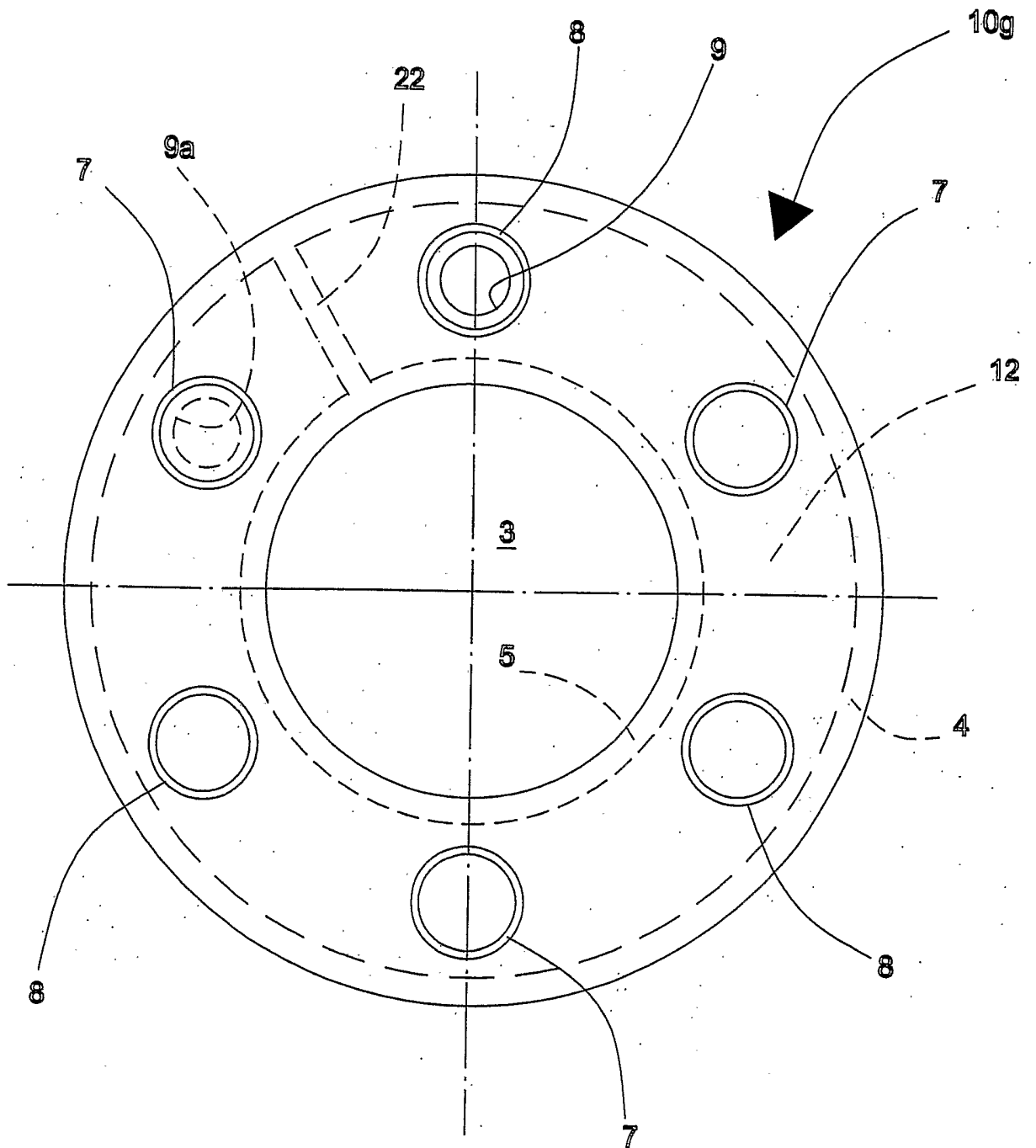

Fig. 20

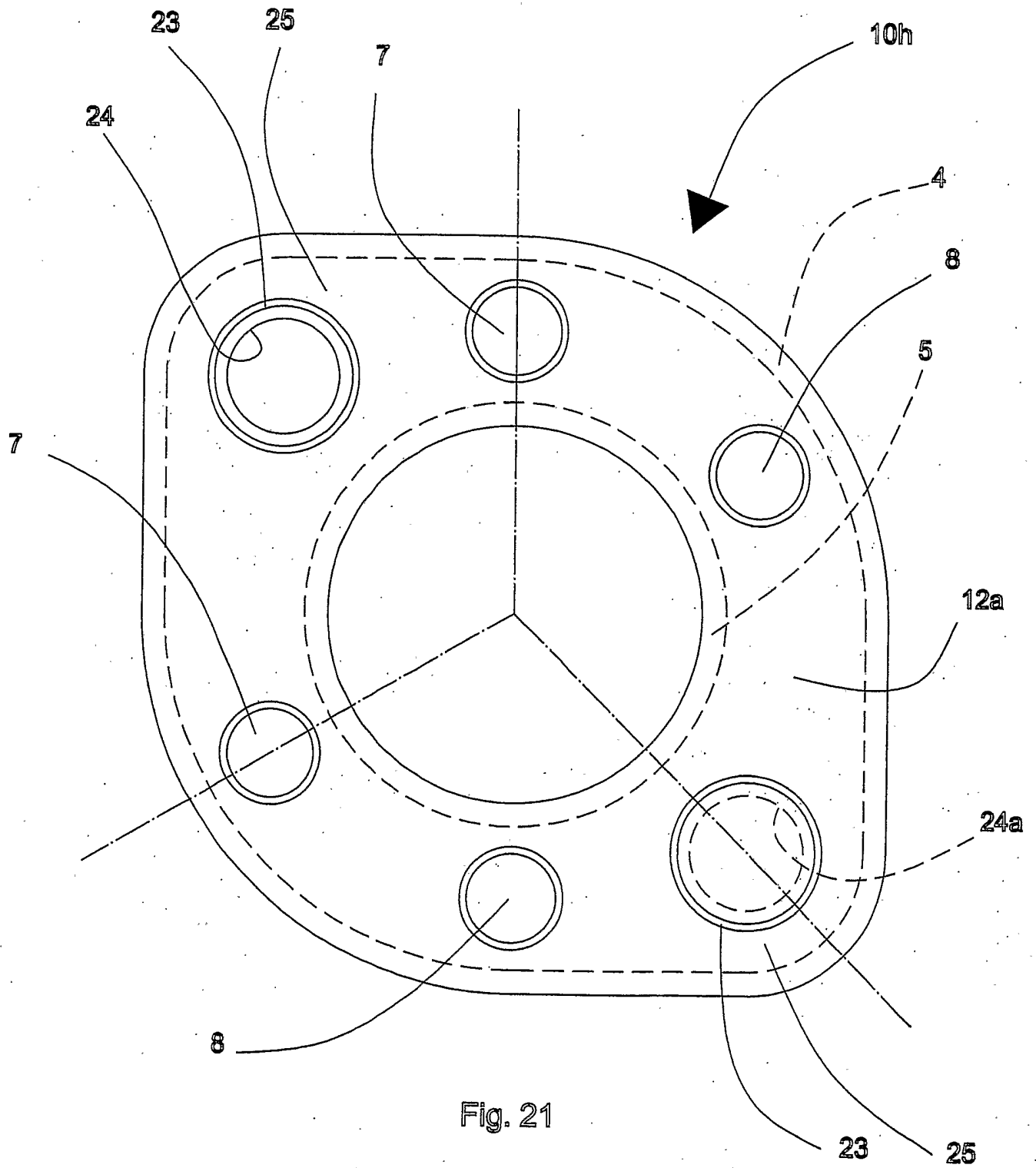

Fig. 21

17/18

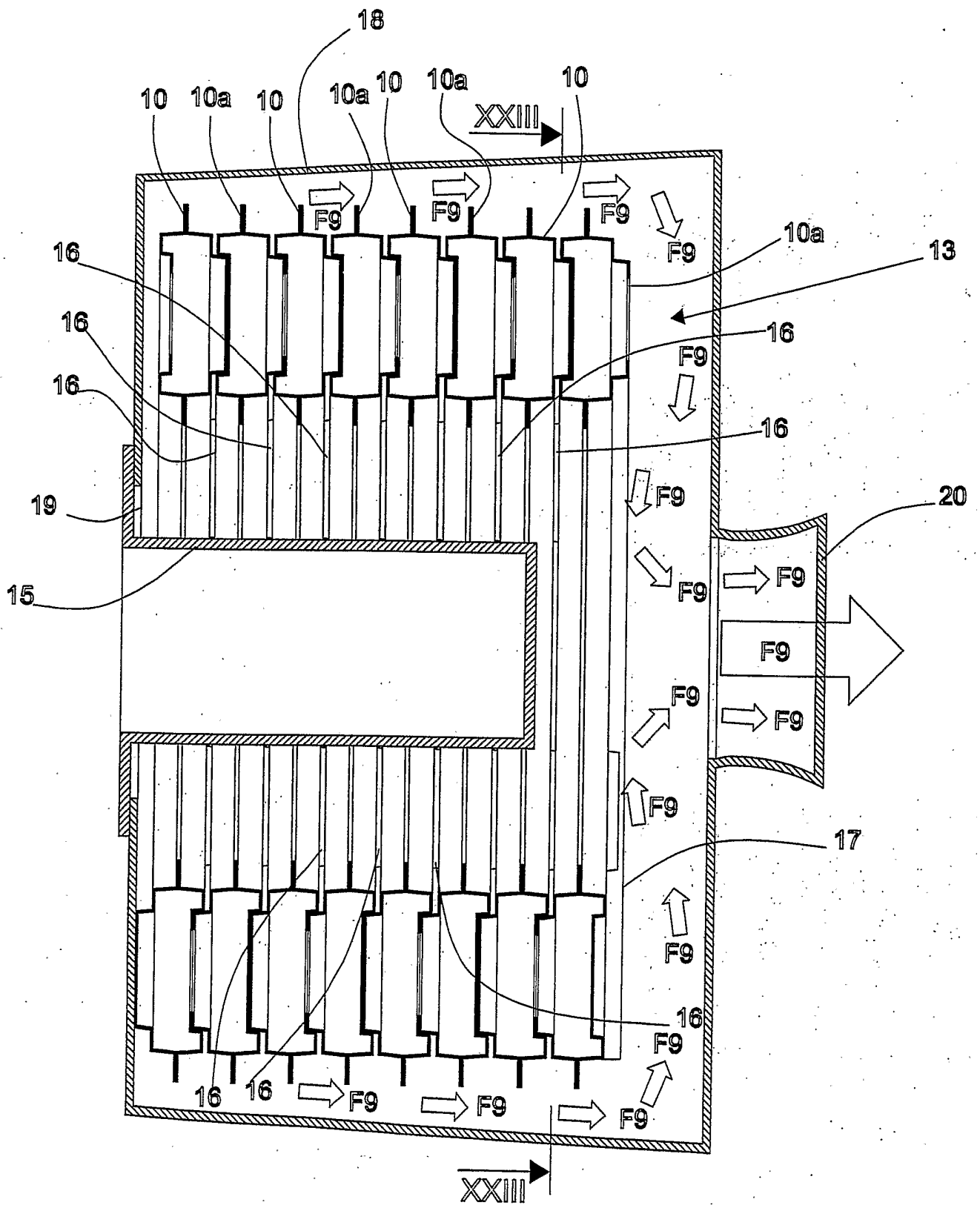

Fig. 22

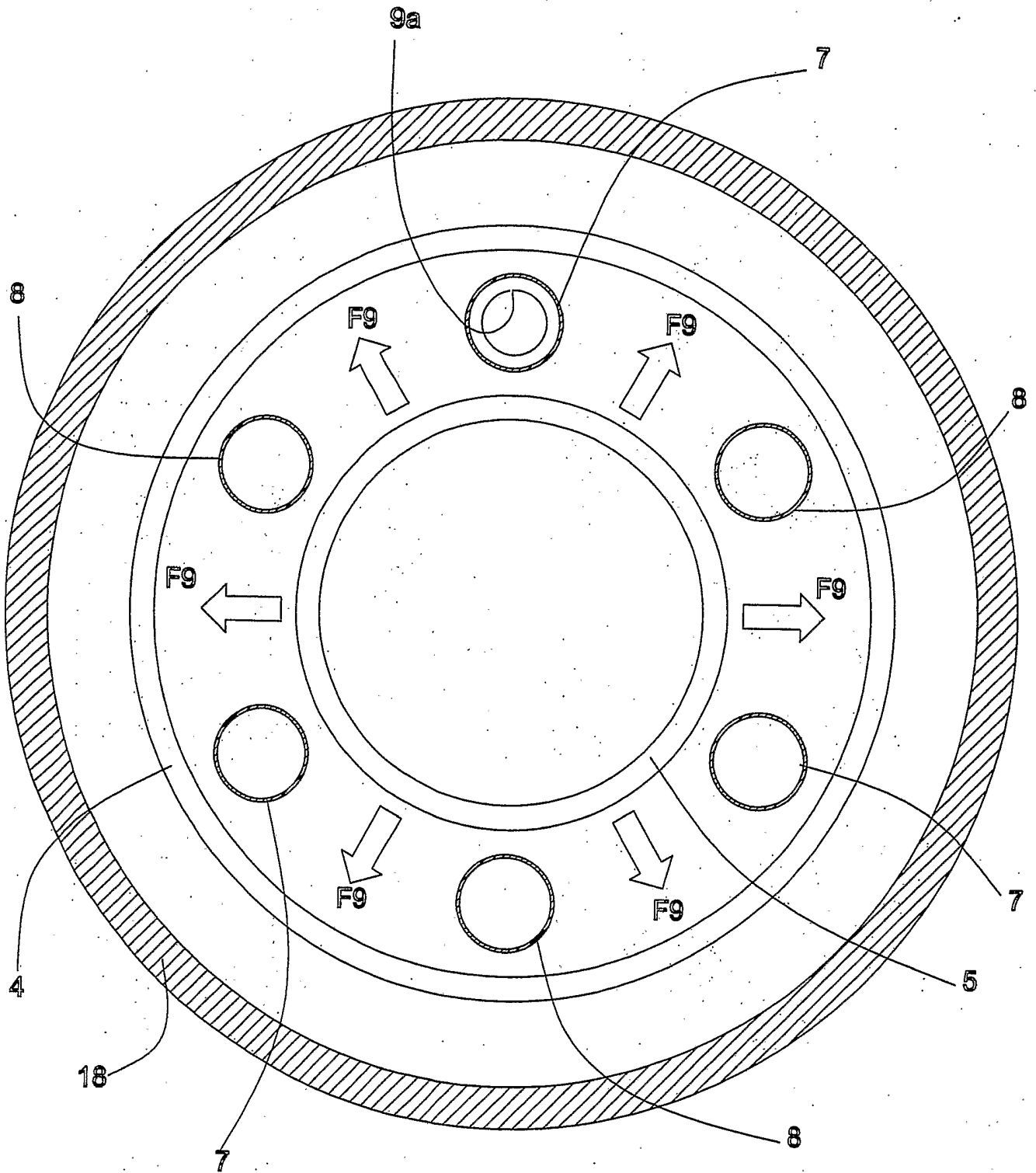

Fig. 23