



- (51) International Patent Classification:
G06Q 10/00 (2012.01) G06Q 30/02 (2012.01)
- (21) International Application Number:
PCT/US2015/065226
- (22) International Filing Date:
11 December 2015 (11.12.2015)
- (25) Filing Language: English
- (26) Publication Language: English
- (30) Priority Data:
62/091,426 12 December 2014 (12.12.2014) US
- (71) Applicant: ECOATM, INC. [US/US]; 10121 Barnes Canyon Road, San Diego, CA 92121 (US).
- (72) Inventor: BOWLES, Mark, Vincent; 10121 Barnes Canyon Road, San Diego, CA 92121 (US).
- (74) Agents: LINCICUM, Matthew, V. et al.; Perkins Coie LLP, P.O. Box 1247, Seattle, WA 98111-1247 (US).
- (81) Designated States (unless otherwise indicated, for every kind of national protection available): AE, AG, AL, AM,

AO, AT, AU, AZ, BA, BB, BG, BH, BN, BR, BW, BY, BZ, CA, CH, CL, CN, CO, CR, CU, CZ, DE, DK, DM, DO, DZ, EC, EE, EG, ES, FI, GB, GD, GE, GH, GM, GT, HN, HR, HU, ID, IL, IN, IR, IS, JP, KE, KG, KN, KP, KR, KZ, LA, LC, LK, LR, LS, LU, LY, MA, MD, ME, MG, MK, MN, MW, MX, MY, MZ, NA, NG, NI, NO, NZ, OM, PA, PE, PG, PH, PL, PT, QA, RO, RS, RU, RW, SA, SC, SD, SE, SG, SK, SL, SM, ST, SV, SY, TH, TJ, TM, TN, TR, TT, TZ, UA, UG, US, UZ, VC, VN, ZA, ZM, ZW.

(84) Designated States (unless otherwise indicated, for every kind of regional protection available): ARIPO (BW, GH, GM, KE, LR, LS, MW, MZ, NA, RW, SD, SL, ST, SZ, TZ, UG, ZM, ZW), Eurasian (AM, AZ, BY, KG, KZ, RU, TJ, TM), European (AL, AT, BE, BG, CH, CY, CZ, DE, DK, EE, ES, FI, FR, GB, GR, HR, HU, IE, IS, IT, LT, LU, LV, MC, MK, MT, NL, NO, PL, PT, RO, RS, SE, SI, SK, SM, TR), OAPI (BF, BJ, CF, CG, CI, CM, GA, GN, GQ, GW, KM, ML, MR, NE, SN, TD, TG).

Published:
— with international search report (Art. 21(3))

WO 2016/094789 A1

(54) Title: SYSTEMS AND METHODS FOR RECYCLING CONSUMER ELECTRONIC DEVICES

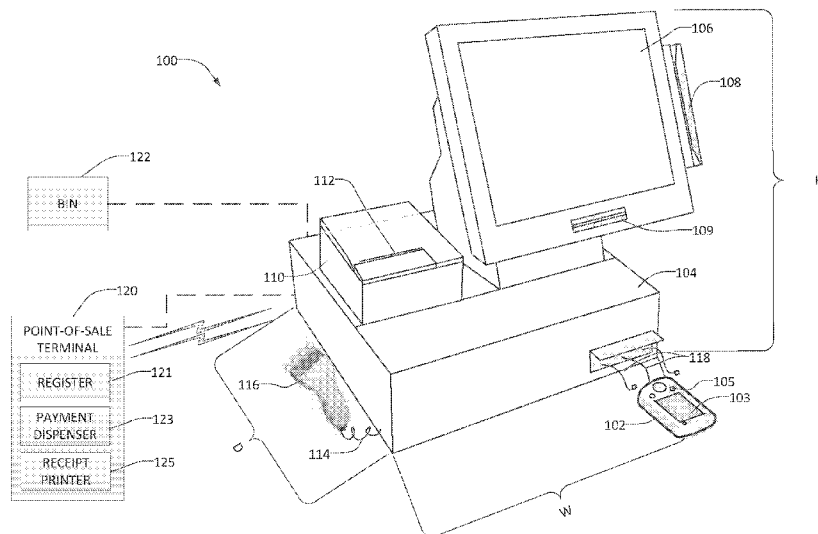

FIG. 1

(57) Abstract: Systems and associated methods for recycling and performing other processes with consumer electronic devices are described herein. In various embodiments, the present technology includes systems and methods for identifying and evaluating a used or pre-owned consumer electronic device, such as a mobile phone, laptop, etc. to facilitate purchasing the device. In some embodiments, the present technology includes a counter-top evaluation terminal that evaluates a device and facilitates purchase and recycling of the device. Various other aspects of the present technology are described herein.

SYSTEMS AND METHODS FOR RECYCLING CONSUMER ELECTRONIC DEVICES

TECHNICAL FIELD

[0001] The present disclosure is directed generally to systems and methods for recycling consumer electronic devices and, more particularly, to systems and methods for identification, evaluation, exchange, return, and/or purchase of consumer electronic devices.

BACKGROUND

[0002] Consumer electronic devices, such as mobile phones, laptop computers, notebooks, tablets, MP3 players, etc., are ubiquitous. Over 300 million desk-based and notebook computers shipped in 2013, and for the first time the number of tablet computers shipped exceeded laptops. In addition, there are over 6 billion mobile devices in use in the world; and the number of these devices is growing rapidly with more than 1.8 billion mobile phones being sold in 2013 alone. By 2017 it is expected that there will be more mobile devices in use than there are people on the planet. Part of the reason for the rapid growth in the number of mobile phones and other electronic devices is the rapid pace at which these devices evolve, and the increased usage of such devices in third world countries.

[0003] As a result of the rapid pace of development, a relatively high percentage of electronic devices are replaced every year as consumers continually upgrade their electronic devices to obtain the latest features. According to the U.S. Environmental Protection Agency, the U.S. alone disposes of over 370 million mobile phones, PDAs, tablets, and other electronic devices every year. Millions of other outdated or broken electronic devices are simply tossed into junk drawers or otherwise kept until a suitable disposal solution arises.

[0004] Although many electronic device retailers now offer mobile phone trade-in or buyback programs, many old devices still end up in landfills or are improperly disassembled and disposed of in developing countries. Unfortunately,

however, electronic devices typically contain substances that can be harmful to the environment, such as arsenic, lithium, cadmium, copper, lead, mercury and zinc. If not properly disposed of, these toxic substances can seep into groundwater from decomposing landfills and contaminate the soil with potentiality harmful consequences for humans and the environment. As an alternative to retailer trade-in or buyback programs, consumers can now recycle and/or sell their used mobile phones using self-service kiosks located in malls or other publically accessible areas. Such kiosks are operated by ecoATM, Inc., the assignee of the present application, and are disclosed in, for example, U.S. Patent Nos.: 8,463,646, 8,423,404, 8,239,262, 8,200,533, 8,195,511, and 7,881,965, which are commonly owned by ecoATM, Inc. and are incorporated herein by reference in their entireties.

[0005] Certain retail establishments and other locations may be reluctant to provide a full-sized kiosk for recycling electronic devices due to the relatively large footprint of the kiosk. Accordingly, there continues to be a need for improving the means available to consumers for recycling or reselling mobile phones and other consumer electronic devices. Simplifying the recycling/reselling process, enhancing the consumer experience, and discouraging fraud can incentivize consumers to dispose of their old electronic devices in an efficient and environmentally conscientious way.

BRIEF DESCRIPTION OF THE DRAWINGS

[0006] Figure 1 is a perspective view of a system configured in accordance with an embodiment of the present technology for recycling electronic devices.

[0007] Figure 2A is a perspective view of another system configured in accordance with an embodiment of the present technology for recycling electronic devices.

[0008] Figure 2B is an enlarged detail view of an inspection area of the system shown in Figure 2A.

[0009] Figure 3A is a perspective view of another system configured in accordance with an embodiment of the present technology for recycling electronic devices.

[0010] Figure 3B illustrates a customer interface of the system shown in Figure 3A.

[0011] Figure 4 is a perspective view of yet another system configured in accordance with an embodiment of the present technology for recycling electronic devices.

[0012] Figure 5 is a diagram illustrating various components associated with the system of Figure 3A.

[0013] Figure 6 is a diagram of a suitable distributed computing environment for implementing various aspects of the present technology.

DETAILED DESCRIPTION

[0014] The following disclosure describes various embodiments of systems and methods for recycling and/or other processing of electronic devices. For example, the following describes various embodiments of systems comprising a compact device evaluation terminal which can be incorporated into or operably coupled with a point-of-sale terminal at a retail establishment for purchasing used mobile phones and/or other electronic devices from consumers at the retail location. Due to the compact form factor, such evaluation terminals can be utilized without sacrificing significant retail space.

[0015] The various embodiments of the systems described herein for recycling electronic devices can be particularly useful for retailers. For example, such systems may allow retailers to offer recycling of electronic devices without the need for specially trained staff members. Additionally, certain state and federal laws may provide incentives for retailers to participate in “takeback” programs that require manufacturers to assist with recycling of electronic devices. Manufacturers often offer warranties or other guarantees that may require receiving and evaluating electronic devices returned by customers. In some instances, retailers may offer buyback programs in order to promote sales of new products, for example offering a customer \$50 towards the purchase of a new mobile phone if the customer brings in an old mobile phone for recycling. In these and other instances, the consumer’s electronic device can be returned at a convenient location using various embodiments of the

evaluation terminals described herein. These embodiments allow the electronic devices to be evaluated, inspected, binned, and compensation to be dispensed to the user. The retailer or other establishment hosting the recycling system may then coordinate with manufacturers or electronics recyclers to pick up the collected electronic devices.

[0016] Certain details are set forth in the following description and in Figures 1–6 to provide a thorough understanding of various embodiments of the present technology. In other instances, well-known structures, materials, operations and/or systems often associated with smartphones and other handheld devices, consumer electronic devices, computer hardware, software, and network systems, etc. are not shown or described in detail in the following disclosure to avoid unnecessarily obscuring the description of the various embodiments of the technology. Those of ordinary skill in the art will recognize, however, that the present technology can be practiced without one or more of the details set forth herein, or with other structures, methods, components, and so forth.

[0017] The terminology used below is to be interpreted in its broadest reasonable manner, even though it is being used in conjunction with a detailed description of certain examples of embodiments of the technology. Indeed, certain terms may even be emphasized below; however, any terminology intended to be interpreted in any restricted manner will be specifically defined as such in this Detailed Description section.

[0018] The accompanying Figures depict embodiments of the present technology and are not intended to be limiting of its scope. The sizes of various depicted elements are not necessarily drawn to scale, and these various elements may be arbitrarily enlarged to improve legibility. Component details may be abstracted in the Figures to exclude details such as position of components and certain precise connections between such components when such details are unnecessary for a complete understanding of how to make and use the invention.

[0019] In the Figures, identical reference numbers identify identical, or at least generally similar, elements. To facilitate the discussion of any particular element, the most significant digit or digits of any reference number refers to the Figure in which

that element is first introduced. For example, element 110 is first introduced and discussed with reference to Figure 1.

[0020] Figure 1 is a schematic perspective view of system that includes an evaluation terminal 100 for recycling and/or other processing of mobile phones and/or other consumer electronic devices in accordance with embodiments of the present technology. The term “processing” is used herein for ease of reference to generally refer to all manner of services and operations that may be performed or facilitated by the system on, with, or otherwise in relation to an electronic device. Such services and operations can include, for example, purchasing, selling, reselling, recycling, donating, exchanging, identifying, evaluating, pricing, auctioning, decommissioning, transferring data from or to, reconfiguring, refurbishing, etc. mobile phones, laptops, personal computers, smart watches, and other electronic devices. Although many embodiments of the present technology are described herein in the context of mobile phones, aspects of the present technology are not limited to mobile phones and generally apply to other consumer electronic devices. Such devices include, as non-limiting examples, notebook and laptop computers, DVRs, e-readers, cameras, televisions, printers, desktop computers, game consoles, all manner of mobile phones, smart phones, handheld devices, PDAs, MP3 players, tablet, etc., as well smaller electronic devices such as Google Glass™, smartwatches (e.g., Apple Watch), other wearable computers, etc. Certain features of the evaluation terminal 100 can be at least generally similar in structure and function to certain features of the kiosks described in U.S. patent numbers: 8,463,646, 8,423,404, 8,239,262, 8,200,533, 8,195,511, and 7,881,965; and in U.S. patent application numbers 12/573,089, 12/727,624, 13/113,497, 12/785,465, 13/017,560, 13/438,924, 13/753,539, 13/658,825, 13/733,984, 13/705,252, 13/487,299, 13/492,835, 13/562,292, 13/658,828, 13/693,032, 13/792,030, 13/794,814, 13/794,816, 13/862,395 and 13/913,408. All of the patents and patent applications listed in the preceding sentence are commonly owned by the applicant of the present application, and they along with any other patents or patent applications identified herein are incorporated herein by reference in their entireties. The disclosed technology also includes U.S. patent application number 14/498,763, titled “METHODS AND SYSTEMS FOR PRICING AND PERFORMING OTHER PROCESSES ASSOCIATED WITH RECYCLING MOBILE PHONES AND OTHER ELECTRONIC DEVICES,” attorney

docket number 111220-8024.US00, filed by the applicant on September 26, 2014; U.S. patent application number 14/500,739, titled "MAINTAINING SETS OF CABLE COMPONENTS USED FOR WIRED ANALYSIS, CHARGING, OR OTHER INTERACTION WITH PORTABLE ELECTRONIC DEVICES," attorney docket number 111220-8025.US00, filed by the applicant on September 29, 2014; U.S. provisional application number 62/059,129, titled "WIRELESS-ENABLED KIOSK FOR RECYCLING CONSUMER DEVICES," attorney docket number 111220-8022.US00, filed by the applicant on October 2, 2014; U.S. provisional application number 62/059,132, titled "APPLICATION FOR DEVICE EVALUATION AND OTHER PROCESSES ASSOCIATED WITH DEVICE RECYCLING," attorney docket number 111220-8023.US00, filed by the applicant on October 2, 2014; U.S. patent application number 14/506,449, titled "SYSTEM FOR ELECTRICALLY TESTING MOBILE DEVICES AT A CONSUMER-OPERATED KIOSK, AND ASSOCIATED DEVICES AND METHODS," attorney docket number 111220-8035.US00, filed by the applicant on October 3, 2014; U.S. provisional application number 62/073,840, titled "SYSTEMS AND METHODS FOR RECYCLING CONSUMER ELECTRONIC DEVICES," attorney docket number 111220-8027.US00, filed by the applicant on October 31, 2014; U.S. provisional application number 62/073,847, titled "METHODS AND SYSTEMS FOR FACILITATING PROCESSES ASSOCIATED WITH INSURANCE SERVICES AND/OR OTHER SERVICES FOR ELECTRONIC DEVICES," attorney docket number 111220-8028.US00, filed by the applicant on October 31, 2014; and U.S. provisional application number 62/076,437, titled "METHODS AND SYSTEMS FOR EVALUATING AND RECYCLING ELECTRONIC DEVICES," attorney docket number 111220-8038.US00, filed by the applicant on November 6, 2014. All of the patents and patent applications listed in the preceding sentence are commonly owned by the applicant of the present application, and they along with any other patents or patent applications identified herein are incorporated herein by reference in their entireties.

[0021] In the illustrated embodiment, the evaluation terminal 100 is a counter-top apparatus configured for use by a user (e.g., a clerk, retail assistant, consumer, customer, etc.) to recycle, sell, return and/or perform other operations with a consumer electronic device 102 (e.g., a smartphone) in, for example, a store, mall, or other retail establishment. In other embodiments, the evaluation terminal 100 can be

configured for use as a floor-mounted or wall-mounted apparatus. Although embodiments of the evaluation terminal 100 can be configured for use by retail clerks or other store employees, in various embodiments the evaluation terminal 100 and/or various portions thereof can also be used entirely or in part by other operators, such as customers or consumers to facilitate the selling or other processing of mobile phones, laptops, smart watches, and other electronic devices.

[0022] In the illustrated embodiment, the evaluation terminal 100 includes a housing 104 that can be of conventional manufacture from, for example, sheet metal, plastic panels, etc. In some embodiments, the evaluation terminal 100 can have a relatively small form factor. For example, the housing 104 can define a footprint having a width W and a depth D , and the evaluation terminal 100 can have a height H . In some embodiments, the width W can be between about 6 inches and about 3 feet, or between about 6 inches and about 2 feet, and the depth D can be between about 6 inches and about 2 feet, or between about 8 inches and about 18 inches. In other embodiments, the width W and the depth D can each be less than about 1 foot. In some embodiments, the total volume of the housing can be less than about 3 cubic feet, less than about 2 cubic feet, or less than about 1 cubic foot. In some embodiments, the height H can be less than about 3 feet, less than about 2 feet, or less than about 1 foot. In other embodiments, the evaluation terminal 100 can have other shapes, sizes, and/or form factors. A plurality of user interface devices are provided on an exterior (e.g., front portion) of the housing 104 for providing instructions and other information to users, and/or for receiving user inputs and other information from users. For example, the evaluation terminal 100 can include a display screen 106 (e.g., a liquid crystal display (LCD)) for providing information, prompts, etc. to users via text, graphics, video, etc. The display screen 106 can include a touch screen for receiving user inputs and responses to displayed prompts. In addition or alternatively, the evaluation terminal 100 can include a separate keyboard or keypad for this purpose. The evaluation terminal 100 can also include a card reader 108 for reading, e.g., magnetic stripes, optical media, etc. on credit cards, bankcards, etc. (e.g., a card swipe and/or credit card reader). An ID card reader 109 is also provided for reading driver's licenses and/or other personal identification cards. The evaluation terminal 100 can additionally include a plurality of output devices such as a printer 110 having an

associated outlet 112. The printer 110 can be configured to print receipts, vouchers, and/or labels. The evaluation terminal 100 can further include a scanner 114 which can be, for example, a hand-held barcode scanner. In some embodiments, the scanner can be a linear barcode reader, a QR code reader, an NFC reader, or other optical or electrical scanning device for scanning and/or reading various forms of machine-readable indicia. In the illustrated embodiment, the scanner 114 is tethered to the evaluation terminal by a cord 116, allowing the user to manually operate the scanner to read a barcode or other indicia on the electronic device 102. In other embodiments, the scanner 114 can be rigidly fixed to the evaluation terminal 100, or in other embodiments the scanner may be physically separated from the evaluation terminal 100 and may wirelessly communicate with the evaluation terminal 100. Unless otherwise noted herein, the card reader 108, the ID card reader 109, the printer 110, the outlet 112, the scanner 114, and the cord 116 described above can be of conventional manufacture and operation as known to those having ordinary skill in the art.

[0023] In the illustrated embodiment, the evaluation terminal 100 further includes a plurality of electrical connectors 118 extending from the housing 104 that are configured to connect to a wide variety of mobile phones and other consumer electronic devices. The connectors 118 can include, for example USB connectors, micro-USB connectors, Lightning connectors, FireWire connectors, etc. for temporary connection to electronic devices that can be received by the evaluation terminal 100, such as mobile phones, laptops, printers, smart watches, etc. The electrical connectors 118 can additionally include an AC plug to provide power for certain devices, e.g., desktop computers, televisions, printers, game consoles, etc.

[0024] In some embodiments, the evaluation terminal 100 may not be integrated with any existing point-of-sale software of a retailer, but the evaluation terminal 100 may nonetheless run on the same computing hardware as the point-of-sale software. In the illustrated embodiment, for example, the evaluation terminal 100 can be operably connected to, but separate from, an existing point-of-sale terminal 120 in the retail establishment. The point-of-sale terminal 120 can include, for example, a conventional register 121, a cash drawer or payment dispenser 123, a receipt printer 125, etc.. The evaluation terminal 100 can be positioned adjacent to the point-of-sale terminal 120 or remote therefrom. The evaluation terminal 100 can be electrically

connected (e.g., wirelessly or via a wired connection) to the point-of-sale terminal 120 and may share computing resources with the point-of-sale terminal 120. In other embodiments described in detail below, the evaluation terminal 100 can also serve as a conventional point-of-sale terminal in a retail establishment. In these embodiments, the evaluation terminal 100 can be integrated with the point-of-sale software of the retailer. Additionally, in these embodiments the evaluation terminal 100 can further include a payment dispenser (not shown) for dispensing payment to a customer. In some embodiments, the payment dispenser can be a cash drawer, a card dispenser (e.g., to dispense gift cards with stored value), a voucher printer, an electronic payment device (e.g., a terminal for making electronic wire transfers, Paypal transfers, Bitcoin transfers, etc.), etc.

[0025] The evaluation terminal 100 can also be associated with a secure storage bin 122 or other collection station or facility for receiving the electronic devices from customers for secure storage, trade-ins, and/or further processing and recycling. In some embodiments, the bin 122 can be remote from the evaluation terminal 100; for example the bin can be positioned in another location within a store, a warehouse, etc. In other embodiments, the bin 122 can be proximate to the evaluation terminal 100, for example the bin 122 can be located beneath the evaluation terminal 100. In some embodiments, the bin 122 can be coupled with a scanner or other reader which can read the identifying labels affixed to electronic devices to identify and record the devices as they are deposited into and/or removed from the bin.

[0026] Although not identified in Figure 1, the evaluation terminal 100 can further include a speaker and/or a headphone jack for audibly communicating information to operators, one or more lights for visually communicating signals or other information to users, a handset or microphone for receiving verbal input from the user, as well as other user input and output devices. The input devices may include a touchpad, a pointing device such as a mouse, a joystick, pen, game pad, motion sensor, scanner, bag/package dispenser, a digital signature pad, etc. The evaluation terminal 100 can include a network connection to receive updates for pricing, grading algorithms, second-hand dealer (SHD) compliance features, etc. In some embodiments, the evaluation terminal 100 can additionally include a camera for

capturing images of a customer, a biometric scanner, and/or other features to facilitate identity evaluation and fraud detection.

[0027] As one example of a recycling process using the evaluation terminal 100, a customer can approach the terminal with an electronic device 102, such as a mobile phone, to be recycled. As noted above, the electronic device can take various other forms, such as a laptop, game console, tablet, wearable computing device, etc. In some embodiments, the customer can hand the electronic device 102 to a clerk at the evaluation terminal 100. The clerk can receive the electronic device 102 and proceed with identification and evaluation. Identification and evaluation of the electronic device 102 can be used to determine a price to offer the customer in exchange for the electronic device 102. In various embodiments, the identification and evaluation process can include electrical analysis of the electronic device 102 by the evaluation terminal 100. In some embodiments, the clerk may initiate the evaluation by interacting with display screen 106 on the evaluation terminal 100. For example, the clerk can indicate the type of device provided by the customer by responding (via, e.g., a touch screen) to a menu and/or prompts on the display screen 106. Next, the clerk may be prompted to remove any cases, stickers, or other accessories from the device 102 so that it can be accurately evaluated. The clerk may also be prompted to plug an appropriate one or more of the electronic connectors 118 into the corresponding port (e.g., a USB port) on the electronic device 102. If needed, the clerk may also plug a suitable power cord for the electronic device 102 into an AC outlet. After connecting the electronic device 102 to one of the electronic connectors 118, the evaluation terminal 100 performs an electrical inspection to confirm the identity and further evaluate the condition of the electronic device 102 as well as specific component and operating parameters such as memory, processor, make, model, etc. In addition or alternatively, in some embodiments the electrical inspection can include a determination of phone manufacturer information (e.g., a vendor identification number or VID) and product information (e.g., a product identification number or PID), and/or determination of the International Mobile Station Equipment Identity (IMEI) number or Mobile Equipment Identifier (MEID) number associated with the device 102. In some embodiments, the electrical analysis can be performed wirelessly, for example via software installed on the electronic device 102 for remote analysis. In some

embodiments, the evaluation terminal 100 can perform the electrical analysis using one or more of the methods and/or systems described in detail in the commonly owned patents and patent applications identified herein and incorporated by reference in their entireties. For example, embodiments of electrical analyses that can be performed by and/or with the evaluation terminal 100 are disclosed in commonly owned U.S. provisional application number 62/076,437, titled "METHODS AND SYSTEMS FOR EVALUATING AND RECYCLING ELECTRONIC DEVICES," attorney docket number 111220-8038.US00, which was filed by the applicant on November 6, 2014 and which is incorporated herein by reference in its entirety.

[0028] In some embodiments, the electrical analysis can include evaluating the condition and/or functionality of the charging circuit of the electronic device 102. In particular, the testing electronics measure the amount of charge current that the charging circuit draws on the power lines, and the testing electronics use the corresponding current measurement signal to determine whether the charging circuit is functional or damaged. In general, charging circuits can become damaged by statistic discharge or when they are overheated, exposed to water, or connected to a non-standard power supply. If a charging circuit is damaged, it might not regulate charge current properly (if at all), which can cause damage to a battery. For example, a damaged charging circuit might have a slow charge rate or a very rapid charge rate. In many cases, a charging circuit is difficult and expensive, if not impossible, to replace because it is typically located on a primary circuit board or co-located on a processor chip. Thus, an electronic device 102 with a damaged charging circuit may have little market value due to the impracticability of replacing the charging circuit.

[0029] In some embodiments, the electrical analysis can include detecting whether a charging circuit is damaged by determining if the current is below a maximum current threshold, above a minimum current threshold, or within a range that falls between the maximum and minimum current thresholds. The testing electronics can also measure other types of electrical quantities associated with the charge current, such as AC frequency or DC pulse widths. For example, in some mobile devices, the charge current may begin to pulse when the battery is fully charged. In an additional or alternate embodiment, the testing electronics can apply an AC test voltage to test capacitors, transistors, or other reactive circuit elements of mobile device hardware.

[0030] In some embodiments, the current measurement signal can be compared to reference quantities corresponding to the electrical characteristics of a particular make and/or model of an electronic device 102. For example, the routine can include looking up device signatures in a look-up table stored in memory. The reference quantities in the device signature can include, for example, the charge current thresholds, the amount of power that the device is supposed to draw on the power line, the expected impedance between the power line and circuit ground, and/or other known reference quantities associated with particular types of makes and/or model of mobile devices.

[0031] In some embodiments, the evaluation terminal 100 can operate via the electrical connectors 118 in a manner similar to that of a USB host device. For example, the evaluation terminal 100 can assign a unique address to the electronic device and exchange USB packets directly with the electronic device 102. For example, in one embodiment the evaluation terminal 100 can request USB device descriptors from the electronic device 102. In some embodiments, the evaluation terminal 100 can communicate via the electrical connector 118 directly with a processor of the electronic device 102 to access the device's hardware components over a debugging interface, such as the android debugging bridge (ADB) or over a hardware abstraction interface. In one embodiment, the evaluation terminal 100 can use such interfaces to operate (e.g., activate, access, control, enable, and/or disable) hardware components, such as the electronic device's camera, display, memory, vibrator motor(s), etc. For example, the evaluation terminal 100 can use a software interface to access the electronic device's memory to retrieve an image and display the image on the device's display screen, if applicable. In another embodiment, the evaluation terminal 100 can communicate with a so-called smart charging circuit, which has logic that enables the charging circuit to be turned on or off and/or to draw different levels of charge current. The evaluation terminal 100 can also use shell access to identify hardware on the electronic device 102. For example, the evaluation terminal 100 can use shell access to detect any non-OEM hardware that may have been installed on the electronic device 102.

[0032] Following the electrical evaluation, in some embodiments the clerk may be prompted to utilize the scanner 114 to scan a barcode on the electronic device

102, or to manually enter a serial number or similar identifying number or feature associated with the electronic device 102. For example, in some electronic devices the serial number or similar identifying number may be visible on an external surface (e.g., displayed on a bottom surface, under a battery, etc.). In some embodiments, a barcode could be included on the electronic device 102 in such a way that the barcode is invisible to the user, but is readable via infrared or ultraviolet light. In some electronic devices, a clerk can navigate an operating system of the electronic device 102 to obtain the serial number or other identifying number. In some embodiments, evaluation of the electronic device 102 can involve user (e.g., clerk) interaction. For example, once the electronic device 102 is connected to one of the electrical connectors 118, the evaluation terminal 100 can electronically communicate with the electronic device via the electrical connector 118, including, for example, instructing the electronic device 102 to start up and run a program or app. The clerk may then be instructed to answer prompts on the screen 103 of the electronic device 102. For example, a message may be displayed on the screen 103 asking the clerk to enter a certain set of characters (e.g., via a touch screen 103 or a keyboard 105 of the electronic device 102). If the clerk correctly enters these characters, then it can be inferred that the screen and/or the keyboard of the electronic device 102 are operative. In some embodiments, the evaluation terminal 100 invokes a message on the screen 103 of the electronic device 102 to be recycled. If the clerk is able to read the message it indicates that the display is functional. If the clerk is then able to use the touch screen 103 or keyboard 105 to reply it indicates that those inputs are also functional. In some embodiments, the clerk interaction with the electronic device 102 can also yield additional information, for example information obtained from the system file of the device 102.

[0033] In some embodiments, the clerk can visually inspect the electronic device 102. For example, the clerk may identify any cracks, scratches, dead pixels, or other damage to the electronic device 102. In some embodiments, the clerk can provide a grade for the electronic device 102 based on the visual inspection (e.g., “poor”, “fair”, “good”, and “excellent” grades, etc.). This grade can be input to the evaluation terminal 100, for example via interaction with a touch screen associated with the display screen 106.

[0034] After the electrical evaluation and/or the visual evaluation of the device 102, the evaluation terminal 100 determines a compensation amount for the electronic device 102. Based on the identification and evaluation of the electronic device 102, the evaluation terminal 100 can determine an estimated price or an estimated range of prices to offer to the customer for the device 102. In some embodiments, the evaluation terminal 100 may query a database comprising a lookup table with various prices for a range of identified electronic devices depending on their evaluated conditions. As one example, the lookup table may indicate that for a particular smartphone make and model, three different prices are available depending on the determined condition (e.g., poor condition - \$100, fair condition - \$200, good condition - \$300). The evaluation terminal 100 may grade the condition of the smartphone automatically based on the visual and/or electrical inspection. Based on the graded condition of the electronic device 102, the evaluation terminal 100 may query the database and receive a compensation amount to be offered to the customer. In some embodiments, the price may not depend on the condition of the electronic device, but only on the make and model. Additional details relating to processes for determining the price for an electronic device are disclosed in commonly owned U.S. Patent Application No. 14/498,763, titled METHODS AND SYSTEMS FOR PRICING AND PERFORMING OTHER PROCESSES ASSOCIATED WITH RECYCLING MOBILE PHONES AND OTHER ELECTRONIC DEVICES, which was filed September 26, 2014, which is incorporated herein by reference in its entirety.

[0035] In some embodiments, determining the compensation amount (purchase price) includes determining whether any specific promotions and/or additional rewards or rebates from the retailer, manufacturer of the device, or any other entity are associated with the electronic device. For example, if mobile phones of a certain brand are eligible for an advertised store credit amount upon trade-in, the evaluation terminal 100 can determine whether the electronic device 102 is eligible and, if so, notify the customer. This can be particularly valuable for retailers who desire to provide a broad spectrum of different promotions for trade-in or trade-up programs to incentivize recycling but face the difficulty for store staff to correctly identify so many different makes and models of different devices, as well as remembering a long list of specific promotions for each. In some embodiments, various options for the

compensation can be determined, for example \$50 in cash or \$100 in store credit towards the purchase of a new device. For example, the evaluation terminal 100 may query a database to determine the price for a particular electronic device based on the evaluated condition. In some embodiments, the database can include a lookup table that includes, in addition to a monetary amount, any applicable rebates, specific promotions, etc. For example, the lookup table may indicate that for a particular identified electronic device having an evaluated condition of "fair" or "good", the price can be either \$50 in cash or \$100 in store credit towards the purchase of a new laptop. Various other promotions, rebates, coupons, and other promotions can be stored in the lookup table. Accordingly, the evaluation terminal 100 may offer a customer a variety of compensation amounts, whether cash, trade-in value, discount coupons, or otherwise, based on the identification and evaluation of the electronic device.

[0036] The determined price or other compensation offers can be presented to the customer. For example, the display screen 106 may display the price, which can be shown to the customer. In another embodiment, the display screen 106 may display the determined price, and the clerk may verbally or otherwise communicate the price to the customer. If the customer declines the offer, then the clerk can disconnect the electronic device 102 from the electrical connector 118 and return the device 102 to the customer. If the customer accepts the offer (e.g., by orally communicating with the clerk, by signing or otherwise acknowledging receipt via digital signature pad, touch screen, etc.), then the evaluation terminal 100 can print an identifying label via printer 110 and outlet 112, which can then be affixed to the electronic device 102. For example, the evaluation terminal 100 may print and dispense a unique identification label (e.g., a small adhesive-backed sticker with a QR code, barcode, etc.) from the label outlet 112 for the clerk to adhere to the electronic device 102. In some embodiments, the printed label can include the obtained information about the electronic device 102, for example its make, model, serial number, condition, its determined value, related promotions, etc. In some embodiments, the identifying label can include machine-readable indicia associated with the identified electronic device. For example, the label can include a barcode, QR code, or other machine-readable indicia that, when scanned, retrieves the obtained information about the electronic device. In some embodiments, additional information obtained from other databases

can be obtained upon reading the machine-readable indicia, including any applicable takeback offers, rebates, coupons, etc. The clerk can also verify the customer's identity by scanning his or her identification card (e.g., driver's license, passport, etc.) with the card reader 108. In some embodiments, the label can be scanned at the point-of-sale terminal 120 prior to dispensing compensation to the user. For example, in some embodiments the point-of-sale terminal 120 can display the device information to the clerk (e.g., via a display screen), and the clerk can visually inspect the electronic device 102 and compare it to the information provided on the display screen to determine whether the device presented by the customer matches the make, model, and other information presented on the display screen. This feature can preclude one type of abuse in which a customer has one device evaluated at the evaluation terminal 100, and then attempts to provide a different device of lesser value to the clerk at the point-of-sale terminal 120 for payment.

[0037] After affixing the label to the electronic device 102, the clerk can store the electronic device in a secure repository, for example in the bin 122. As noted above, in some embodiments the bin 122 can be remote from the evaluation terminal 100, for example the bin 122 can be positioned in another location within a store. In some embodiments, the bin 122 can be proximate to the evaluation terminal 100, for example the bin 122 can be positioned beneath the evaluation terminal 100. In some embodiments, the electronic device 102 can be added, either automatically or manually by the clerk, to an inventory database before or when it is placed in the bin 122. The database can be networked to other inventories, manufacturers, resellers, etc. For example, a database may be maintained that includes, for a particular device, the make, model, quantity of such devices in a particular bin 122 and/or in other facilities at remote locations, compensation amount(s) paid to customers for such devices, customers demographic information, and other information. The database can be periodically updated as new devices are purchased from customers and devices are retained in the bin 122. The inventory database can also be used to facilitate recycling of the devices. For example, a retailer may be able to contact an electronics recycler and easily provide information regarding the number and type of devices in the inventory. Pick-up may be scheduled based on volume and/or time from the selected collection agency, and the collection agency would be prepared with a complete list of

what inventory to expect. This inventory database can additionally provide valuable information regarding which manufacturers and models are being recycled, optionally cross-referenced with customers demographic data. Further, the inventory data can be useful to retailers to demonstrate compliance with state and federal regulations regarding electronics recycling and takeback programs.

[0038] After binning the electronic device 102, the clerk may dispense compensation to the customer from, e.g., the point-of-sale terminal 120. In some embodiments, payment can be made in the form of cash, a redeemable voucher, a coupon, a discount on another device, an e-certificate, a prepaid card, a wired or wireless monetary deposit to an electronic account (e.g., a bank account, credit account, loyalty account, online commerce account, mobile wallet, etc.), Bitcoin, etc. In some embodiments, the evaluation terminal 100 can automatically fill out any forms of paperwork necessary for the customer to obtain a refund, rebate, or other compensation from the manufacturer or other entity. The completed forms can be provided to the customer for submission or may be submitted automatically on behalf of the customer.

[0039] Figure 2A is a schematic perspective view of a system for recycling and/or other processing of mobile phones and other consumer electronic devices in accordance with the present technology. The system includes an evaluation terminal 200 that is generally similar in structure and function in some respects to the evaluation terminal 100 described above in Figure 1. As in Figure 1, for example, the evaluation terminal 200 includes a housing 204, the display screen 106 (which may include a touch screen), the card reader 108 (e.g., a credit card reader, etc.), the ID card reader 109, the printer 110 having the outlet 112 (e.g., for printing vouchers, receipts, labels, etc.), and the scanner 114 (e.g., barcode scanner) coupled to the terminal 200 via the cord 116. The evaluation terminal 200 can also be associated with a bin or other collection station or facility for receiving the electronic devices from customers for secure storage, trade-ins, and/or further processing and recycling. In some embodiments, the evaluation terminal 200 can also serve as a conventional point-of-sale terminal in a retail establishment. In these embodiments, the evaluation terminal 200 can be integrated with the point-of-sale software of the retailer and can include, for

example, a cash drawer or other payment dispenser (not shown) for dispensing payment to a customer for the used electronic device 102.

[0040] Whereas the evaluation terminal 100 of Figure 1 includes electrical connectors 118 that are accessible from outside the housing 104, the evaluation terminal 200 includes an enclosable inspection area 220 configured as a drawer 221 within the housing 104. The inspection area 220 is illustrated in greater detail in Figure 2B. As illustrated in Figure 2B, the inspection area 220 includes a plurality of electrical connectors 218 which can include, for example, USB connectors, micro-USB connectors, Lightning connectors, FireWire connectors, etc. for temporary connection to the electronic device 102, such as a mobile phone, when the electronic device 102 is positioned within the inspection area 220, such as a mobile phone. The inspection area 220 can also be configured to receive other electronic devices, such as laptops, smart watches, etc. that can be connected to one or more of the electrical connectors 218. The electrical connectors 218 can additionally include a power connector, such as an AC plug, to provide power for certain devices, e.g., printers, game consoles, etc. An adjustable fixture or cradle 219 can be sized and configured to receive the electronic device 102 in the inspection area 220. The cradle 219 can be adjustable, for example, guide portions 225 can be slidable to accommodate electronic devices having various widths.

[0041] In the illustrated embodiments, the inspection area 220 comprises a first imaging component 222 disposed on or proximate a lower surface 224 of the inspection area 220. The first imaging component 222 can be or include, for example, a flatbed scanner or other imaging system (e.g., a digital camera) capable of capturing images of the electronic device 102. A second imaging component 226 can be disposed within the evaluation terminal 200 at a position above the inspection area 220 when the drawer 221 is closed and the inspection area 220 is disposed within the housing 104. For example, when the drawer 221 is closed, the second imaging component 226 can be substantially aligned over the first imaging component 222. The second imaging component 226 can be or include, for example, a flatbed scanner or other imaging system (e.g., a digital camera, etc.) capable of capturing images of the electronic device 102. Together, the first imaging component 222 and the second imaging component 226 can capture images of opposite sides (e.g., top and bottom

sides or surfaces) of the electronic device 102 when the device is positioned within the inspection area 220. In some embodiments, one or more appropriately positioned/angled mirrors (not shown) may also be disposed about the inspection area 220 to facilitate imaging of other portions of an electronic device 102, such as side surfaces. In some embodiments more or fewer imaging components can be provided within the evaluation terminal 200. One or more optional light source 223 (e.g., LED, fluorescent bulb, etc.) can be disposed within the inspection area 220, and can be configured to illuminate the electronic device 102 to facilitate imaging by the imaging components 222 and 226.

[0042] As one example of a recycling process using the evaluation terminal 200, a customer can approach the terminal with the electronic device 102 to be recycled, such as a mobile phone. This process can be similar in some respects to that described above with respect to Figure 1. For example, a clerk can receive the customer's electronic device 102 and place it in, e.g., the cradle 219 or other fixture for proper orientation within the inspection area 220, and connect the electronic device 102 to one of the electrical connectors 218. Electrical identification and evaluation of the electronic device 102 can proceed as described above with reference to Figure 1. However, the inspection area 220 further enables automated visual inspection and evaluation of the electronic device by way of the first imaging component 222 and the second imaging component 226.

[0043] In some embodiments, the first and second imaging components 222, 226 can be configured to obtain a serial number or similar identifying number that may be visible on an external surface of the electronic device 102. For example, in some embodiments, the electronic device 102 can include a barcode on an external surface that is invisible to the user, but is readable via infrared or ultraviolet light. In some embodiments, one or both of the imaging components 222, 226 can include an infrared light source and/or an infrared reader configured to detecting barcodes or other indicia on the electronic device 102. The evaluation terminal 200 can also identify and inspect the device by analyzing images obtained via the imaging components 222, 226. For example, in some embodiments, the visual inspection can include a 3D visual analysis to determine the size of the device 102 and confirm the identification of the electronic device 102 (e.g. make and model) based on size, and/or to evaluate or

assess the condition and/or function of the electronic device 102 and/or its various components and systems. In some embodiments, the visual inspection can include a computer-implemented visual analysis (e.g., a three-dimensional (“3D”) analysis) performed by a processor within the evaluation terminal 200 (e.g., a CPU) to confirm the identification of the electronic device 102 (e.g. make, model and/or sub-model) and/or to evaluate or assess the condition and/or function of the electronic device 102 and/or its various components and systems. For example, the visual analysis can include computer-implemented evaluation (e.g., a digital comparison) of images of the electronic device 102 taken by the imaging components 222, 226 from top, side and/or end view perspectives to determine length, width, and/or height (thickness) dimensions of the electronic device 102. This comparison can include, for example, counting pixels along various dimensions in each image. In some embodiments, the visual analysis can include an inspection of a display screen on the electronic device 102 for cracks or other damage. In various embodiments, the evaluation terminal 200 can perform the visual analysis using one or more of the methods and/or systems described in detail in the commonly owned patents and patent applications identified herein and incorporated by reference in their entireties.

[0044] After visual and electrical inspection and evaluation of the electronic device 102, the process can continue as outlined above with respect to Figure 1. For example, an offer price for the electronic device 102 can be determined and offered to the customer. If the customer accepts the offer price, a corresponding label can be printed and dispensed from the outlet 112 and affixed to the electronic device 102, compensation can be dispensed to the customer, and the electronic device 102 can be binned.

[0045] Figure 3A is a schematic perspective view of another system for recycling and/or other processing of mobile phones and other consumer electronic devices in accordance with embodiments of the present technology. The system includes an evaluation terminal 300 that can be generally similar in structure and function in some respects to the evaluation terminal 100 described above with respect to Figure 1 and the evaluation terminal 200 described above with respect to Figures 2A–B. For example, the evaluation terminal 300 includes a housing 204, the display screen 106 (which may include a touch screen), the card reader 108 (e.g., an

identification card reader, credit card reader, etc.), the ID card reader 109, the printer 110 having the outlet 112 (e.g., for printing vouchers, receipts, labels, etc.), and the scanner 114 (e.g., barcode scanner) coupled to the terminal 300 via the cord 116. The evaluation terminal 300 also includes the inspection area 220 as a drawer within the housing 204. The inspection area 220 can be similar to that described above with respect to Figure 2B, for example including a plurality of electrical connectors and imaging components to facilitate evaluation of the electronic device.

[0046] In the illustrated embodiment, the evaluation terminal 300 additionally includes a customer interface 328 configured to face a customer 329 at the terminal 300. A detailed front view of the customer interface 328 is illustrated in Figure 3B. In some embodiments, a plurality of user interface devices are provided on an exterior (e.g., front portion) of the customer interface 328 for providing instructions and other information to customers, and/or for receiving customer inputs and other information from customers. For example, the customer interface 328 can include a display screen 330 (e.g., a liquid crystal display (LCD)) for providing information, prompts, etc. to customers via text, graphics, video, etc. The display screen 330 can include a touch screen for receiving customer inputs and responses to displayed prompts. In addition or alternatively, the customer interface 328 can include or be operably connected to a separate keyboard or keypad for this purpose. The customer interface 328 can also include a card reader 332 (e.g., a card swipe and/or credit card reader) and an ID card reader 333 (e.g., a driver's license card reader).

[0047] The customer interface 328 of the evaluation terminal 300 can further include one or more cameras 334 (e.g., a digital still camera, a video camera, etc.) which can be configured to face and view and/or photograph the customer 329 during the transaction. A biometric scanner 336 (e.g., a fingerprint scanner) is also provided. The camera 334 and biometric scanner 336 can be utilized for customer identity verification and to avoid fraud.

[0048] Although not identified in Figure 3B, the customer interface 328 can further include a speaker and/or a headphone jack for audibly communicating information to customers, one or more lights for visually communicating signals or other information to customers, a handset or microphone for receiving verbal input from the customer, as well as other user input and output devices. The input devices may

include a touchpad, a pointing device such as a mouse, a joystick, pen, game pad, motion sensor, scanner, bag/package dispenser, a digital signature pad, etc.

[0049] As one example of a recycling process using the evaluation terminal 300, the customer 329 can approach the terminal with the electronic device 102 (e.g., a mobile phone; Figure 2A) for recycling or selling to the retailer. This process can be substantially similar in some respects to that described above with reference to Figures 2A–B, however the customer interface 328 of the evaluation terminal 300 provides additional functionality. More specifically, a clerk 331 can receive the customer's electronic device 102 and place it within the inspection area 220 and connect it to one of the electrical connectors 118, and then close the drawer 221 as described above with reference to Figures 2A–B. Electrical and visual identification and evaluation of the electronic device 102 can proceed as outlined above with reference to Figures 2A–B. After evaluation, an offer price can be determined and presented to the customer via the display screen 330. If the customer accepts the offer price, the identity of the customer can be verified via the customer interface 328. In some embodiments, for example, the customer may be prompted to place his or her identification (e.g., a driver's license) in the ID card reader 333 and/or provide a thumbprint via the biometric scanner 336. As a fraud prevention measure, the evaluation terminal 300 can be configured to transmit an image of the driver's license to a remote computer screen, and an operator at the remote computer can visually compare a display of the picture (and/or other information) on the driver's license to the person standing in front of the evaluation terminal 300, e.g., the customer 329, as viewed by the camera 334 to confirm that the person attempting to sell the electronic device 102 is in fact the person identified by the driver's license. In some embodiments, the camera 334 may be movable to facilitate viewing of customers, as well as other individuals in the proximity of the evaluation terminal 300. In some embodiments a plurality of cameras 334 can be provided. In some embodiments, one or more images of the customer, the customer's identification card, biometric readings (e.g., fingerprint), etc. can be stored or recorded for later access. This can be useful in particular if the transaction is later found to be fraudulent. Additionally, the customer's fingerprint can be checked against records of known fraud perpetrators. If either of these checks indicate that the person selling the electronic device presents a fraud risk, the transaction can be declined and the

electronic device 102 returned. In some embodiments, the customer can be prompted to enter additional information via the display screen 330, for example make and model, place or purchase, customer demographic information (gender, age, location, etc.).

[0050] Once the customer's identification is verified, an associated label can be printed via the printer 110 and affixed to the electronic device 102. The clerk can bin the electronic device 102 and dispense compensation to the customer as described above with reference to Figures 1–2B.

[0051] Figure 4 is a schematic perspective view of another system for recycling and/or other processing of mobile phones and other consumer electronic devices in accordance with embodiments of the present technology. The system includes an evaluation terminal 400 as well as a cashier terminal 450 that is separate from the evaluation terminal 400. In the illustrated embodiment, the evaluation terminal 400 can be configured for use by a customer to evaluate and price the electronic device 102, after which the customer can take the evaluated electronic device to a clerk at the cashier terminal 450 to submit the device and receive compensation.

[0052] The evaluation terminal 400 is similar in some respects to the evaluation terminals 100, 200, and 300 described in detail above. For example, the evaluation terminal 400 includes the housing 204, the display screen 106 (which may include a touch screen), the card reader 108 (e.g., a cardswipe reader, credit card reader, etc.), the ID card reader 109 (e.g., a driver's license reader), and the printer 110 having the outlet 112 (e.g., for printing vouchers, receipts, labels, etc.). The evaluation terminal 400 also includes the inspection area 220 as a drawer within the housing 204. The inspection area 220 can be similar to that described above with respect to Figure 2B, for example including a plurality of electrical connectors and imaging components to facilitate evaluation of the electronic device.

[0053] In the illustrated embodiments, the evaluation terminal 400 additionally includes one or more cameras 334 which can be configured to face the customer during the transaction. A biometric scanner 336 (e.g., a fingerprint scanner) is also provided. The camera 334 and biometric scanner 336 can be utilized for user identity verification and to avoid fraud. Although not identified in Figure 4, the evaluation terminal 400 can further include a speaker and/or a headphone jack for audibly communicating information to customers, one or more lights for visually

communicating signals or other information to customers, a handset or microphone for receiving verbal input from the customer, as well as other user input and output devices. The input devices may include a touchpad, a pointing device such as a mouse, a joystick, pen, game pad, motion sensor, scanner, bag/package dispenser, a digital signature pad, etc.

[0054] The cashier terminal 450 can be substantially similar in many respects to a conventional cashier terminal, and can include, for example, a housing 454 that can be of conventional manufacture from, for example, sheet metal, plastic panels, etc. A plurality of user interface devices are provided on an exterior (e.g., front portion) of the housing 454 for providing instructions and other information to users, and/or for receiving user inputs and other information from users. For example, the cashier terminal 450 can include a display screen 456 (e.g., a liquid crystal display (LCD)) for providing information, prompts, etc. to users via text, graphics, video, etc. The display screen 456 can include a touch screen for receiving user inputs and responses to displayed prompts. In addition or alternatively, the cashier terminal 450 can include a separate keyboard or keypad for this purpose. The cashier terminal 450 can also include a card reader 458 (e.g., a driver's license and/or credit card reader). The cashier terminal 450 can additionally include a plurality of output devices such as a printer 460 having an associated outlet 462. The printer 460 can be configured to print receipts, vouchers, and/or labels. The cashier terminal 450 can further include a scanner 464 which can be, for example, a hand-held barcode scanner. In some embodiments, the scanner can be a linear barcode reader, a QR code reader, an NFC reader, or other optical or electrical scanning device. In the illustrated embodiment, the scanner 464 is tethered to the evaluation terminal by a cord 466, allowing the user to manually operate the scanner to read a barcode or other indicia on the electronic device. In other embodiments, the scanner can be rigidly fixed to the cashier terminal 450, or in other embodiments the scanner may be physically separated from the cashier terminal 450 and may wirelessly communicate with the cashier terminal 450.

[0055] In some embodiments, the cashier terminal 450 can also serve as a conventional point-of-sale terminal in a retail establishment. For example, in some embodiments the cashier terminal 450 can include a payment dispenser 468 (e.g., a cash drawer) for dispensing payment to a customer. In some embodiments, the

payment dispenser 468 can be or include a card dispenser (e.g., to dispense gift cards with stored value), a voucher printer, an electronic payment device (e.g., a terminal for making electronic wire transfers, Paypal transfers, Bitcoin transfers, etc.), etc. In some embodiments, the cashier terminal 450 can be coupled to, but separate from, the point-of-sale terminal in a retail establishment. Although not identified in Figure 4, the cashier terminal 450 can further include a speaker and/or a headphone jack for audibly communicating information to operators, one or more lights for visually communicating signals or other information to users, a handset or microphone for receiving verbal input from the user, as well as other user input and output devices. The input devices may include a touchpad, a pointing device such as a mouse, a joystick, pen, game pad, motion sensor, scanner, bag/package dispenser, a digital signature pad, etc.

[0056] The cashier terminal 450 can also be associated with a bin or other collection station or facility for receiving the electronic devices from customers for secure storage, trade-ins, and/or further processing and recycling. In some embodiments, the bin can be remote from the other components of the cashier terminal 450, for example the bin can be positioned in another location within the store in which the terminals 400 and 450 are located, a warehouse, etc. In some embodiments, the bin can be proximate to the other components, for example the bin can be located beneath the cashier terminal 450. In some embodiments, the bin can be coupled with a scanner or other reader which can read the identifying labels affixed to electronic devices as they are deposited into and/or removed from the bin.

[0057] As one example of a recycling process using the evaluation terminal 400, a customer can approach the evaluation terminal 400 with the electronic device 102 (Figure 2B) for recycling, such as a mobile phone. This process can be similar in some respects to that described above with reference to Figures 1–3B. In the embodiment of Figure 4, however, the evaluation terminal 400 can be configured for customer operation. For example, the customer can approach the evaluation terminal 400, interact with prompts on the display screen 106, and initiate evaluation of the electronic device 102 by placing it in the inspection area 220 and connecting it to one or more of the electrical connectors 218 (e.g., a USB connector, power adapter, etc., see Figure 2B), and shutting the drawer to place the electronic device 102 within the inspection area 220. Electrical and visual inspection and analysis can then be

performed on the electronic device 102 as described above with respect to Figures 2A–3B. In the illustrated embodiment, the evaluation terminal 400 can verify the identity of the customer by means of the camera 334, the card reader 108, the ID card reader 109, and/or the biometric scanner 336, similar to that described above with respect to Figures 3A–3B. After a price is determined and offered to the customer (e.g., via display screen 106), and the customer accepts the offer price (e.g., via a touch screen or other input), a label can be printed via printer 110 and dispensed via the outlet 112. The customer can then apply the label to the electronic device 102 and take the electronic device 102 to the cashier terminal 450, or in some other embodiments the customer can bring both the label (or instead another type of identification document, e.g., receipt, voucher, etc.) and the electronic device 102 to the cashier terminal 450 without affixing the label to the electronic device 102.

[0058] In some embodiments, the identifying label can include machine-readable indicia associated with the identified electronic device 102. For example, the label can include a barcode, QR code, or other machine-readable indicia that, when scanned at the cashier terminal 450 via scanner 464, retrieves the obtained information about the electronic device. In some embodiments, information obtained from the evaluation and identification performed at the evaluation terminal 400 can be stored electronically and may be retrieved by the cashier terminal 450 upon reading the machine-readable indicia. In some embodiments, additional information obtained from other databases can be obtained upon reading the machine-readable indicia, including any applicable takeback offers, rebates, coupons, etc.

[0059] The scanner 464 can be, for example a barcode reader, QR code reader, or other such scanner. In some embodiments, the clerk at the cashier terminal 450 can use the scanner 464 to read the barcode, QR code, and/or other machine-readable indicia on the label presented by the customer to download the information about the electronic device 102 onto the cashier terminal 450. After scanning the label and downloading the device information, the device identity and/or condition can be verified at the cashier terminal 450. For example, in some embodiments the cashier terminal 450 can display the device information to the clerk on the display screen 456, and the clerk can visually inspect the electronic device 102 and compare it to the information provided on the display screen 456 to determine whether the device

presented by the customer matches the make, model, and other information presented on the display screen 456. In some embodiments, to further facilitate device verification, the display 456 at the cashier terminal 450 can show a stock image of the identified electronic device 102, which can allow the clerk to perform a quick visual comparison between the stock image and the electronic device presented by the customer. For example, if the customer presents a low-end smart phone to the clerk, but after scanning the label the display 456 shows a stock image of a high-end feature phone, the clerk can terminate the transaction. This feature can preclude one type of abuse in which a customer has one device evaluated at the evaluation terminal 400, and then attempts to provide a different device of lesser value to the clerk at the cashier terminal 450 for payment. In some embodiments, rather than a stock image of the device, actual images of the device that the customer evaluated at the evaluation terminal 400 can be used. For example, images taken with cameras 334 while the device was being evaluated at the evaluation terminal 400 can be displayed on the display screen 456 of the terminal 400 for comparison by the clerk. In other embodiments, the clerk may electrically connect the electronic device 102 to electrical connectors provided at the cashier terminal 450. Electrical analysis can then be used to determine whether the presented device matches the device evaluated at the evaluation terminal 400. In some embodiments, the cashier terminal 450 may access a remote server computer 470 to obtain information associated with the electronic device in order to verify that the device presented at the cashier terminal 450 matches the device evaluated at the evaluation terminal 400. For example, the cashier terminal 450 may query databases stored on the remote server computer to retrieve device information and/or pricing information. Once the customer's identification is verified and the device identity and condition is verified, the clerk can dispense compensation to the customer and bin the electronic device 102.

[0060] Figure 5 provides a schematic representation of an architecture of the evaluation terminal 100, 200, 300, 400 in accordance with an embodiment of the present technology. In the illustrated embodiment, the evaluation terminal can be any one of the evaluation terminals 100, 200, 300, and 400 described above, and will be referred to herein as "evaluation terminal 300" for ease of reference. The evaluation terminal 300 includes a suitable processor or central processing unit ("CPU") 500 that

controls operation of the evaluation terminal 300 in accordance with computer-readable instructions stored on system memory 506. The CPU 500, for example, can control performance of the various routines associated with processing and evaluating electronic devices as described herein. The CPU 500 may be any logic processing unit, such as one or more CPUs, digital signal processors (DSPs), application-specific integrated circuits (ASICs), etc. The CPU 500 may be a single processing unit or multiple processing units in a device or distributed across multiple devices. The CPU 500 is connected to the memory 506 and may be coupled to other hardware devices, for example, with the use of a bus (e.g., a PCI Express or Serial ATA bus). The CPU 500 can include, by way of example, a standard personal computer ("PC") (e.g., a DELL OPTIPLEX 780 or 7010 PC) or other type of embedded computer running any suitable operating system, such as Linux, Windows, Android, iOS, MAC OS, or an embedded real-time operating system. In some embodiments, the CPU 500 can be a small form factor PC with integrated hard disk drive ("HDD") or solid-state drive ("SSD") and universal serial bus ("USB") or other ports to communicate with the other components of the evaluation terminal 300. In other embodiments, the CPU 500 can include a microprocessor with a standalone motherboard that interfaces with a separate HDD. The memory 506 can include read-only memory (ROM) and random access memory (RAM) or other storage devices, such as disk drives or SSDs, that store the executable applications, test software, databases and other software required to, for example, implement the various routines described herein, control evaluation terminal components, process electronic device information and data (to, e.g., evaluate device make, model, condition, pricing, etc.), communicate and exchange data and information with remote computers and other devices, etc.

[0061] The CPU 500 can provide information and instructions to evaluation terminal users via the display screens 106, 330 and/or an audio system (e.g., a speaker) 504. The CPU 500 can also receive user inputs via, e.g., a touch screen 508 associated with the display screen 106, a keypad with physical keys, and/or a microphone 510. Additionally, the CPU 500 can receive personal identification and/or biometric information associated with users via the card/ID readers 108, 109, 332, 333, one or more of the external cameras 334, and/or the biometric scanner 336. In some embodiments, the CPU 500 can also receive information (such as user identification

and/or account information) via a card reader 108 (e.g., a debit, credit, or loyalty card reader having, e.g., a suitable magnetic stripe reader, optical reader, etc.). The CPU 500 can also receive information from the scanner 114 and the customer interface 328. The CPU 500 can control operation of the printer 110 and systems for providing remuneration to users, such as a cash dispenser and/or a receipt or voucher printer and an associated dispenser. The CPU can also control operation of the light source 332.

[0062] As noted above, the evaluation terminal 300 additionally includes a number of electronic, optical and electromechanical devices for electrically, visually and/or physically analyzing electronic devices placed therein for recycling. Such systems can include one or more internal cameras (e.g., imaging components 222, 226) for visually inspecting electronic devices to, e.g., determine the external dimensions and condition, and one or more of the electrical connectors 118, 218 (e.g., USB connectors) for, e.g., powering up electronic devices and performing electronic analyses. As noted above, the imaging components 222, 226 can be operably coupled to the inspection area 220. The evaluation terminal 300 further includes power 502, which can include battery power and/or facility power for operation of the various electrical components associated with evaluation terminal operation.

[0063] In the illustrated embodiment, the evaluation terminal 300 further includes a network connection 512 (e.g., a wired connection, such as an Ethernet port, cable modem, FireWire cable, Lightning connector, USB port, etc.) suitable for communication with, e.g., all manner of processing devices (including remote processing devices) via a communication link 550, and a wireless transceiver 514 (e.g., including a Wi-Fi access point; Bluetooth transceiver; near-field communication (NFC) device; wireless modem or cellular radio utilizing GSM, CDMA, 3G and/or 4G technologies; etc.) suitable for communication with, e.g., all manner of processing devices (including remote processing devices) via the communication link 550 and/or directly via, e.g., a wireless peer-to-peer connection. For example, the wireless transceiver 514 can facilitate wireless communication with electronic devices, such as a mobile device 102 (e.g., a smartphone) either in the proximity of the evaluation terminal 300 or remote therefrom. In the illustrated embodiment, the electronic device 102 is depicted as a mobile device, e.g., a mobile phone. In other embodiments, however, the

electronic device 102 can be other types of electronic devices including, for example, other handheld devices; PDAs; MP3 players; tablet, notebook, laptop and desktop computers; e-readers; cameras; TVs; DVRs; game consoles; Google Glass™; smart-watches; other wearable computers, etc. By way of example only, in the illustrated embodiment the mobile device 102 can include one or more features, applications and/or other elements commonly found in smartphones and other known mobile devices. For example, the mobile device 102 can include a CPU and/or a graphics processing unit (“GPU”) 534 for executing computer readable instructions stored on memory 536. In addition, the mobile device 102 can include an internal power source or battery 532, a dock connector 546, a USB port 548, a camera 540, and/or well-known input devices, including, for example, a touch screen 542, a keypad, etc. In many embodiments, the mobile device 102 can also include a speaker 544 for two-way communication and audio playback. In addition to the foregoing features, the mobile device 102 can include a mobile operating system (OS) 531 and/or a device wireless transceiver that may include one or more antennas 538 for wirelessly communicating with, for example, other mobile devices, websites, and the evaluation terminal 300. Such communication can be performed via, e.g., the communication link 550 (which can include the Internet, public and private intranet, a local or extended Wi-Fi network, cell towers, the plain old telephone system (POTS), etc.), direct wireless communication, etc.

[0064] Unless described otherwise, the construction and operation of the various components shown in Figure 5 are of conventional design. As a result, such components need not be described in further detail herein, as they will be readily understood by those skilled in the relevant art. In other embodiments, the evaluation terminal 300 and/or the mobile device 102 can include other features that may be different from those described above. In still further embodiments, the evaluation terminal 300 and/or the mobile device 102 can include more or fewer features similar to those described above.

[0065] Figure 6 is a schematic diagram of a suitable network environment for implementing various aspects of an electronic device recycling system 600 configured in accordance with embodiments of the present technology. In the illustrated embodiment, a plurality of the evaluation terminals 300 (identified individually

as evaluation terminals 300a–300n) can exchange information with one or more remote computers (e.g., one or more server computers 604) via the communication link 550. Although described with reference to the evaluation terminal 300, a similar architecture can be employed for the other embodiments described herein (e.g., the evaluation terminal 100, evaluation terminal 200, evaluation terminal 400, and cashier terminal 450). Although the communication link 550 can include a publically available network (e.g., the Internet with a web interface), a private communication link, such as an intranet or other network may also be used. Moreover, in various embodiments the individual evaluation terminal 300 can be connected to a host computer (not shown) that facilitates the exchange of information between the evaluation terminals 300 and remote computers, other terminals, mobile devices, etc.

[0066] The server computer 604 can perform many or all of the functions for receiving, routing and storing electronic messages, such as webpages, audio signals and electronic images necessary to implement the various electronic transactions described herein. For example, the server computer 604 can retrieve and exchange web pages and other content with an associated database or databases 606. In some embodiments, the database 606 can include information related to mobile phones and/or other consumer electronic devices. Such information can include, for example, make, model, serial number, IMEI, MEID, carrier plan information, pricing information, owner information, etc., as well as dimensional information (size, shape, location of displays, ports, etc.) and other visual information (e.g., logo shapes, sizes, locations, etc.) associated with known devices, such as particular device models, sub-models, etc. In various embodiments the server computer 604 can also include a server engine 608, a web page management component 610, a content management component 612, and a database management component 614. The server engine 608 can perform the basic processing and operating system level tasks associated with the various technologies described herein. The web page management component 610 can handle creation and/or display and/or routing of web or other display pages. The content management component 612 can handle many of the functions associated with the routines described herein. The database management component 614 can perform various storage, retrieval and query tasks associated with the database 606, and can store various information and data such as animation, graphics, visual and audio

signals, etc. Those of ordinary skill in the art will appreciate that many of the routines and/or portions thereof and other functions and methods described above can be performed by the evaluation terminal 300 (e.g., the processor 500), the server computer 604, or both.

[0067] In the illustrated embodiment, the evaluation terminals 300 can also be operably connected to a plurality of other remote devices and systems via the communication link 550. For example, the evaluation terminals 300 can be operably connected to a plurality of user devices 618 (e.g., personal computers, laptops, handheld devices, etc.) having associated browsers 620. Similarly, as described above the evaluation terminals 300 can each include wireless communication facilities for exchanging digital information with mobile devices, such as the mobile device 102. The evaluation terminals 300 and/or the server computer 604 are also operably connectable to a series of remote computers for obtaining data and/or exchanging information with necessary service providers, financial institutions, device manufactures, authorities, government agencies, etc. For example, the evaluation terminals 300 and the server computer 604 can be operably connected to one or more cell carriers 622, one or more device manufacturers 624 (e.g., mobile phone manufacturers), one or more electronic payment or financial institutions 628, one or more databases (e.g., the GSMA International Mobile Equipment Identity Database, etc.), and one or more computers and/or other remotely located or shared resources associated with cloud computing 626. The financial institutions 628 can include all manner of entity associated with conducting financial transactions, including banks, credit/debit card facilities, online commerce facilities, online payment systems, virtual cash systems, money transfer systems, etc.

[0068] In addition to the foregoing, the evaluation terminals 300 and the server computer 604 can also be operably connected to a resale marketplace 630 and an operator 632. The resale marketplace 630 represents a system of remote computers and/or services providers associated with the reselling of consumer electronic devices through both electronic and brick-and-mortar channels. Such entities and facilities can be associated with, for example, online auctions for reselling used electronic devices as well as for establishing market prices for such devices. The operator 632 can be a central computer or system of computers for controlling all

manner of operation of the network of evaluation terminals 300. Such operations can include, for example, remote monitoring and facilitating of evaluation terminal maintenance (e.g., remote testing of terminal functionality, downloading operational software and updates, etc.), servicing (e.g., periodic replenishing of cash and other consumables), performance, etc. In addition, the operator 632 can further include one or more display screens operably connected to cameras located at each of the evaluation terminals 300 (e.g., one or more of the cameras 334 described above with reference to Figure 3B). This remote viewing capability enables operator personnel to verify user identification and/or make other visual observations at the evaluation terminals 300 in real-time during transactions.

[0069] The foregoing description of the electronic device recycling system 600 illustrates but one possible network system suitable for implementing the various technologies described herein. Accordingly, those of ordinary skill in the art will appreciate that other systems consistent with the present technology can omit one or more of the facilities described in reference to Figure 6 or may include one or more additional facilities not described in detail in Figure 6.

[0070] Those of ordinary skill in the art will appreciate that the routines and other functions and methods described above can be performed by various processing devices, such as the processor 500 (Figure 5), the server computer 604 (Figure 6), or both. The processes can be implemented as an application specific integrated circuit (ASIC), by a digital signal processing (DSP) integrated circuit, through conventional programmed logic arrays or circuit elements. While many of the embodiments are shown and described as being implemented in hardware (e.g., one or more integrated circuits designed specifically for a task), such embodiments could equally be implemented in software and be performed by one or more processors. Such software can be stored on any suitable computer-readable medium, such as microcode stored in a semiconductor chip, on a computer-readable disk, or downloaded from a server and stored locally at a client.

[0071] The evaluation terminals 300, mobile devices 102, server computers 604, user computers and/or other user devices 618, etc. may include one or more central processing units or other logic-processing circuitry, memory, input devices (e.g., keyboards and pointing devices), output devices (e.g., display devices and printers),

and storage devices (e.g., magnetic, solid state, fixed and floppy disk drives, optical disk drives, etc.). Such computer devices may include other program modules such as an operating system, one or more application programs (e.g., word processing or spread sheet applications), and the like. The user computers may include wireless computers, such as mobile phones, personal digital assistants (PDAs), palm-top computers, etc., which communicate with the Internet via a wireless link. The computers may be general-purpose devices that can be programmed to run various types of applications, or they may be single-purpose devices optimized or limited to a particular function or class of functions. Aspects of the invention may be practiced in a variety of other computing environments.

[0072] While the Internet is shown, a private network, such as an intranet may likewise be used herein. The network may have a client-server architecture, in which a computer is dedicated to serving other client computers, or it may have other architectures such as peer-to-peer, in which one or more computers serve simultaneously as servers and clients. A database or databases, coupled to the server computer(s), stores much of the web pages and content exchanged between the user computers. The server computer(s), including the database(s), may employ security measures to inhibit malicious attacks on the system and preserve the integrity of the messages and data stored therein (e.g., firewall systems, message encryption and/or authentication (e.g., using transport layer security (TLS) or secure socket layers (SSL)), password protection schemes, encryption of stored data (e.g., using trusted computing hardware), and the like).

[0073] One skilled in the relevant art will appreciate that the concepts of the invention can be used in various environments other than location based or the Internet. In general, a display description may be in HTML, XML or WAP format, email format or any other format suitable for displaying information (including character/code-based formats, algorithm-based formats (e.g., vector generated), and bitmapped formats). Also, various communication channels, such as local area networks, wide area networks, or point-to-point dial-up connections, may be used instead of the Internet. The system may be conducted within a single computer environment, rather than a client/server environment. Also, the user computers may comprise any combination of hardware or software that interacts with the server computer, such as

television-based systems and various other consumer products through which commercial or noncommercial transactions can be conducted. The various aspects of the invention described herein can be implemented in or for any e-mail environment.

[0074] Although not required, aspects of the invention are described in the general context of computer-executable instructions, such as routines executed by a general-purpose data processing device, e.g., a server computer, wireless device or personal computer. Those skilled in the relevant art will appreciate that aspects of the invention can be practiced with other communications, data processing, or computer system configurations, including Internet appliances, hand-held devices (including personal digital assistants (PDAs)), wearable computers, all manner of cellular or mobile phones (including Voice over IP (VoIP) phones), dumb terminals, media players, gaming devices, multi-processor systems, microprocessor-based or programmable consumer electronics, set-top boxes, network PCs, mini-computers, mainframe computers, and the like. Indeed, the terms "computer," "server," "host," "host system," and the like, are generally used interchangeably herein, and refer to any of the above devices and systems, as well as any data processor. Input devices may include a touchpad, keyboard and/or a pointing device such as a mouse. Other input devices are possible such as a microphone, joystick, pen, game pad, scanner, digital camera, video camera, and the like. The data storage devices may include any type of computer-readable media that can store data accessible by a computer, such as magnetic hard and floppy disk drives, optical disk drives, magnetic cassettes, tape drives, flash memory cards, digital video disks (DVDs), Bernoulli cartridges, RAMs, ROMs, smart cards, etc. Indeed, any medium for storing or transmitting computer-readable instructions and data may be employed, including a connection port to a network such as a local area network (LAN), wide area network (WAN) or the Internet.

[0075] Aspects of the invention can be embodied in a special purpose computer or data processor that is specifically programmed, configured, or constructed to perform one or more of the computer-executable instructions explained in detail herein. While aspects of the invention, such as certain functions, are described as being performed exclusively on a single device, the invention can also be practiced in distributed environments where functions or modules are shared among disparate processing devices, which are linked through a communications network, such as a

Local Area Network (LAN), Wide Area Network (WAN), or the Internet. In a distributed computing environment, program modules may be located in both local and remote memory storage devices.

[0076] Aspects of the invention may be stored or distributed on tangible computer-readable media, including magnetically or optically readable computer discs, hard-wired or preprogrammed chips (e.g., EEPROM semiconductor chips), nanotechnology memory, biological memory, or other data storage media. The data storage devices may include any type of computer-readable media that can store data accessible by a computer, such as magnetic hard and floppy disk drives, optical disk drives, magnetic cassettes, tape drives, flash memory cards, DVDs, Bernoulli cartridges, RAM, ROMs, smart cards, etc. Indeed, any medium for storing or transmitting computer-readable instructions and data may be employed, including a connection port to a network such as a LAN, WAN, or the Internet. Alternatively, computer implemented instructions, data structures, screen displays, and other data under aspects of the invention may be distributed over the Internet or over other networks (including wireless networks), on a propagated signal on a propagation medium (e.g., an electromagnetic wave(s), a sound wave, etc.) over a period of time, or they may be provided on any analog or digital network (packet switched, circuit switched, or other scheme). The terms “memory” and “computer-readable storage medium” include any combination of temporary, persistent, and/or permanent storage, e.g., ROM, writable memory such as RAM, writable non-volatile memory such as flash memory, hard drives, solid state drives, removable media, and so forth, but do not include a propagating signal per se.

[0077] The above Detailed Description of examples and embodiments of the invention is not intended to be exhaustive or to limit the invention to the precise form disclosed above. While specific examples for the invention are described above for illustrative purposes, various equivalent modifications are possible within the scope of the invention, as those skilled in the relevant art will recognize. References throughout the foregoing description to features, advantages, or similar language do not imply that all of the features and advantages that may be realized with the present technology should be or are in any single embodiment of the invention. Rather, language referring to the features and advantages is understood to mean that a specific

feature, advantage, or characteristic described in connection with an embodiment is included in at least one embodiment of the present technology. Thus, discussion of the features and advantages, and similar language, throughout this specification may, but do not necessarily, refer to the same embodiment. Furthermore, the described features, advantages, and characteristics of the present technology may be combined in any suitable manner in one or more embodiments. One skilled in the relevant art will recognize that the present technology can be practiced without one or more of the specific features or advantages of a particular embodiment. In other instances, additional features and advantages may be recognized in certain embodiments that may not be present in all embodiments of the present technology.

[0078] Any patents and applications and other references noted above, including any that may be listed in accompanying filing papers, are incorporated herein by reference. Aspects of the invention can be modified, if necessary, to employ the systems, functions, and concepts of the various references described above to provide yet further implementations of the invention.

[0079] Unless the context clearly requires otherwise, throughout the description and the claims, the words "comprise," "comprising," and the like, are to be construed in an inclusive sense, as opposed to an exclusive or exhaustive sense; that is to say, in the sense of "including, but not limited to." As used herein, the terms "connected," "coupled," or any variant thereof, means any connection or coupling, either direct or indirect, between two or more elements; the coupling or connection between the elements can be physical, logical, or a combination thereof. Additionally, the words "herein," "above," "below," and words of similar import, when used in this application, refer to this application as a whole and not to any particular portions of this application. Where the context permits, words in the above Detailed Description using the singular or plural number may also include the plural or singular number respectively. The word "or," in reference to a list of two or more items, covers all of the following interpretations of the word: any of the items in the list, all of the items in the list, and any combination of the items in the list.

[0080] The teachings of the invention provided herein can be applied to other systems, not necessarily the system described above. The elements and acts of the various examples described above can be combined to provide further

implementations of the invention. Some alternative implementations of the invention may include not only additional elements to those implementations noted above, but also may include fewer elements. Further any specific numbers noted herein are only examples—alternative implementations may employ differing values or ranges.

[0081] While the above description describes various embodiments of the invention and the best mode contemplated, regardless how detailed the above text, the invention can be practiced in many ways. Details of the system may vary considerably in its specific implementation, while still being encompassed by the present disclosure. As noted above, particular terminology used when describing certain features or aspects of the invention should not be taken to imply that the terminology is being redefined herein to be restricted to any specific characteristics, features, or aspects of the invention with which that terminology is associated. In general, the terms used in the following claims should not be construed to limit the invention to the specific examples disclosed in the specification, unless the above Detailed Description section explicitly defines such terms. Accordingly, the actual scope of the invention encompasses not only the disclosed examples, but also all equivalent ways of practicing or implementing the invention under the claims.

[0082] From the foregoing, it will be appreciated that specific embodiments of the invention have been described herein for purposes of illustration, but that various modifications may be made without deviating from the spirit and scope of the various embodiments of the invention. Further, while various advantages associated with certain embodiments of the invention have been described above in the context of those embodiments, other embodiments may also exhibit such advantages, and not all embodiments need necessarily exhibit such advantages to fall within the scope of the invention. Accordingly, the invention is not limited, except as by the appended claims. Although certain aspects of the invention are presented below in certain claim forms, the applicant contemplates the various aspects of the invention in any number of claim forms. Accordingly, the applicant reserves the right to pursue additional claims after filing this application to pursue such additional claim forms, in either this application or in a continuing application.

CLAIMS

I/We claim:

1. A system for recycling electronic devices, the system comprising:
a housing configured for placement and operation on a counter top;
a user interface operably coupled to the housing and configured to receive user input associated with an electronic device;
at least one electrical connector operably coupled to the housing and configured to connect to the electronic device; and
a processor within the housing and in communication with the electrical connector and the user interface, the processor configured to:
electrically interact with the electronic device via the electrical connector;
facilitate determining a compensation value for the electronic device, wherein the compensation value is at least partially based on the electrical interaction with the electronic device.
2. The system of claim 1 wherein the processor is further configured to associate the electronic device with a unique identifier.
3. The system of claim 1 wherein the housing defines a volume of less than two cubic feet.
4. The system of claim 1, further comprising a point-of-sale terminal operably connectable to the processor, wherein the point-of-sale terminal includes:
a display screen; and
a payment dispenser.
5. The system of claim 1 wherein the electrical connector extends from the housing and is configured to connect to the electronic device external to the housing.

6. The system of claim 1, further comprising an inspection area within the housing, the inspection area containing the electrical connector and at least one imaging component configured to obtain an image of the electronic device when the electronic device is disposed on the inspection area.

7. The system of claim 6, wherein the processor is in communication with the imaging component, the processor further configured to visually inspect the electronic device based on the image.

8. The system of claim 6 wherein the inspection area comprises a movable drawer.

9. The system of claim 8 wherein the at least one imaging component comprises a flatbed scanner disposed within the drawer.

10. The system of claim 8 wherein the drawer is manually openable and closeable by a user.

11. The system of claim 8 wherein the drawer includes an adjustable fixture to position a device relative to the imaging component.

12. The system of claim 1 wherein the user interface includes a first display for displaying first information to a clerk, and wherein the system further comprises a customer interface, the customer interface comprising a second display for displaying second information to the customer.

13. The system of claim 12 wherein the customer interface further comprises:
a camera; and
a card reader.

14. The system of claim 12 wherein the customer interface further comprises a biometric scanner.

15. The system of claim 12 wherein the first display faces a first direction and the second display faces in a second direction opposite the first direction.

16. The system of claim 1 wherein the system is configured to facilitate recycling of at least one of: a mobile phone, a wearable computer, a laptop computer, a tablet, an MP3 player, a DVD player, and a camera.

17. A system for recycling electronic devices, the system comprising:
an evaluation terminal comprising:
a user interface configured to receive user input associated with an electronic device; and
a first processor in communication with the electrical connector, the first processor configured to:
electrically interact with the electronic device via the electrical connector;
facilitate determining a compensation value for the electronic device, wherein the compensation value is at least partially based on the electrical interaction with the electronic device;
and
associate the electronic device with a unique identifier; and
a cashier terminal operably connected to the evaluation terminal, comprising:
a second processor configured to:
receive the unique identifier; and
at least partially verify the electronic device based on the unique identifier.

18. The system of claim 17 wherein the evaluation terminal further comprises an inspection area comprising at least one electrical connector configured to connect to the electronic device.

19. The system of claim 17 wherein the second processor is further configured to:

when the device has been at least partially verified, cause the cashier terminal to dispense the compensation value to the user in exchange for the electronic device.

20. The system of claim 17 wherein the evaluation terminal further comprises: a housing enclosing the first processor; and an inspection area, wherein the inspection area comprises at least one imaging component, wherein the first processor is configured to visually inspect the electronic device via the imaging component, and wherein the compensation is at least partially based on the visual inspection.

21. The system of claim 17 wherein the evaluation terminal is configured to facilitate recycling of a mobile phone, a wearable computer, a laptop computer, a tablet, an MP3 player, a DVD player, and a camera.

22. The system of claim 17, further comprising a secure binning area having a third processor configured to receive the unique identifier and at least partially verify the electronic device based on the unique identifier, the secure binning area configured to receive the electronic device after the compensation value has been dispensed to the user.

23. The system of claim 17 wherein the evaluation terminal further comprises an imaging component, wherein the cashier terminal further comprises a display, wherein the first processor is configured to obtain an image of the user via the imaging component, and wherein the second processor is configured to display the image of the user at the cashier terminal.

24. The system of claim 17 wherein the evaluation terminal further comprises an identification card reader in communication with the first processor, wherein the identification card reader is configured to obtain an image of an identification card; wherein the cashier terminal further comprises a display, and wherein the second processor is configured to display an image at the cashier

terminal of the user obtained from a user identification card obtained by the identification card reader.

25. The system of claim 17 wherein the cashier terminal further comprises a display, and wherein the second processor is configured to display an image of the electronic device after receiving the unique identifier.

26. The system of claim 25 wherein the image comprises a sample image of a sample electronic device similar to the electronic device associated with the unique identifier.

27. The system of claim 25 wherein the image comprises an image obtained of the electronic device at the evaluation terminal.

28. The system of claim 17 wherein the evaluation terminal further comprises a means for verifying an identity of the user.

29. The system of claim 17 wherein the evaluation terminal further comprises a means for imaging the electronic device.

30. A method for purchasing an electronic device, the method comprising:
providing an evaluation terminal, the evaluation terminal having:
a housing configured for placement and operation on a counter-top;
a user interface operably coupled to the housing and configured to receive user input associated with an electronic device;
at least one electrical connector configured to connect to the electronic device; and
a processor within the housing and in communication with the electrical connector and the user interface;
electrically interacting with the electronic device via the electrical connector; and
determining a compensation value for the electronic device, wherein the compensation value is at least partially based on the electrical interaction with the electronic device.

31. The method of claim 30, further comprises dispensing the compensation value to a user for the electronic device.

32. The method of claim 30 wherein the evaluation terminal further comprises an imaging component in communication with the processor, the method further comprising:

obtaining an image of the electronic device.

33. The method of claim 30 wherein the electronic device is submitted by a user, and wherein the method further comprises validating an identification of the user.

34. The method of claim 30 wherein providing the evaluation terminal comprises providing the evaluation terminal in a retail establishment.

35. The method of claim 30 wherein the processor is operably connected to a point-of-sale terminal, wherein the point-of-sale terminal includes:

a display screen;

a payment dispenser; and

a printer.

36. The method of claim 30, further comprising electrically evaluating the electronic device via the electrical connector; and

determining a price for the electronic device based at least in part on the electrical evaluation.

37. The method of claim 30, further comprising associating the electronic device with a unique identifier.

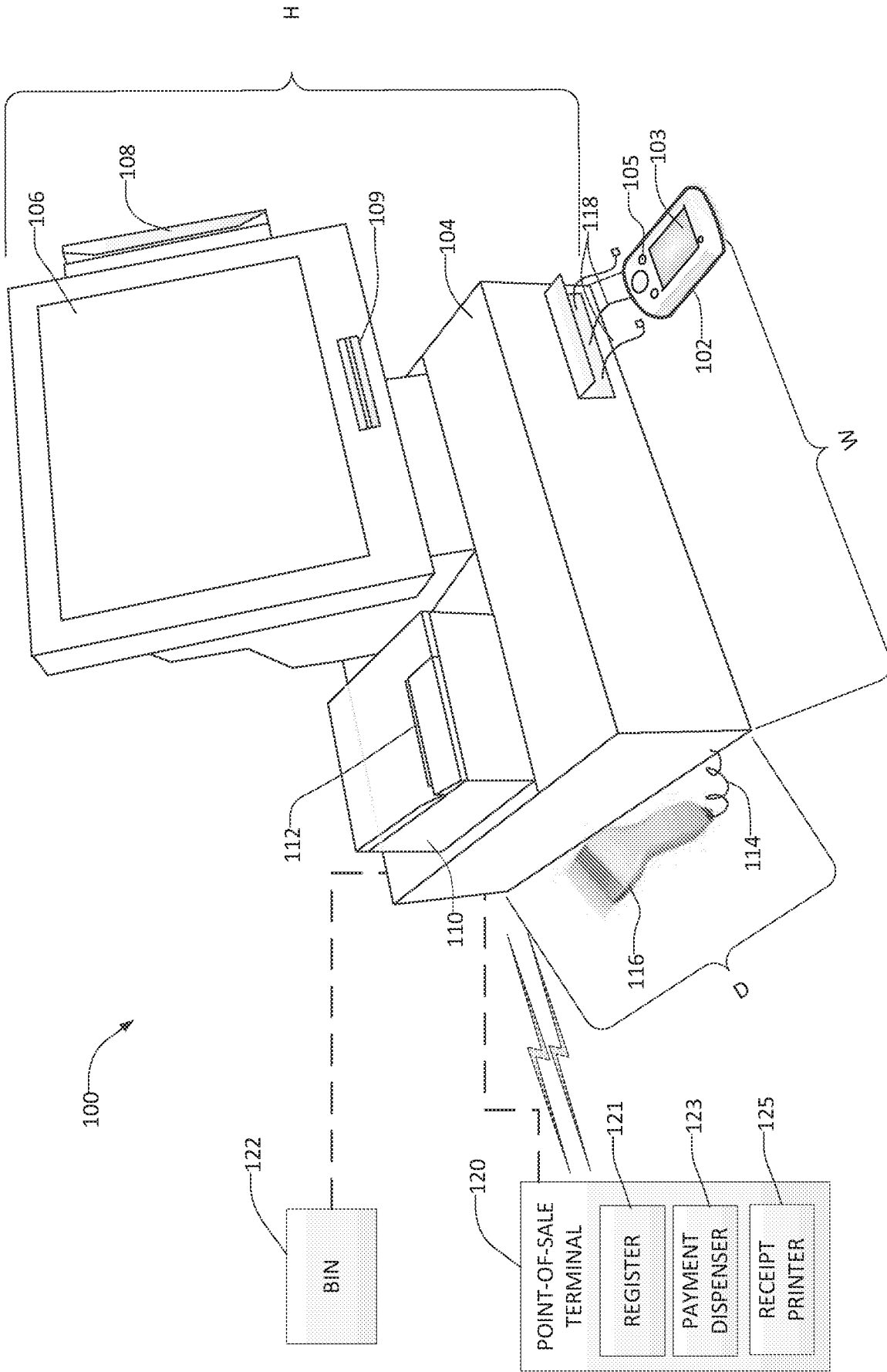

FIG. 1

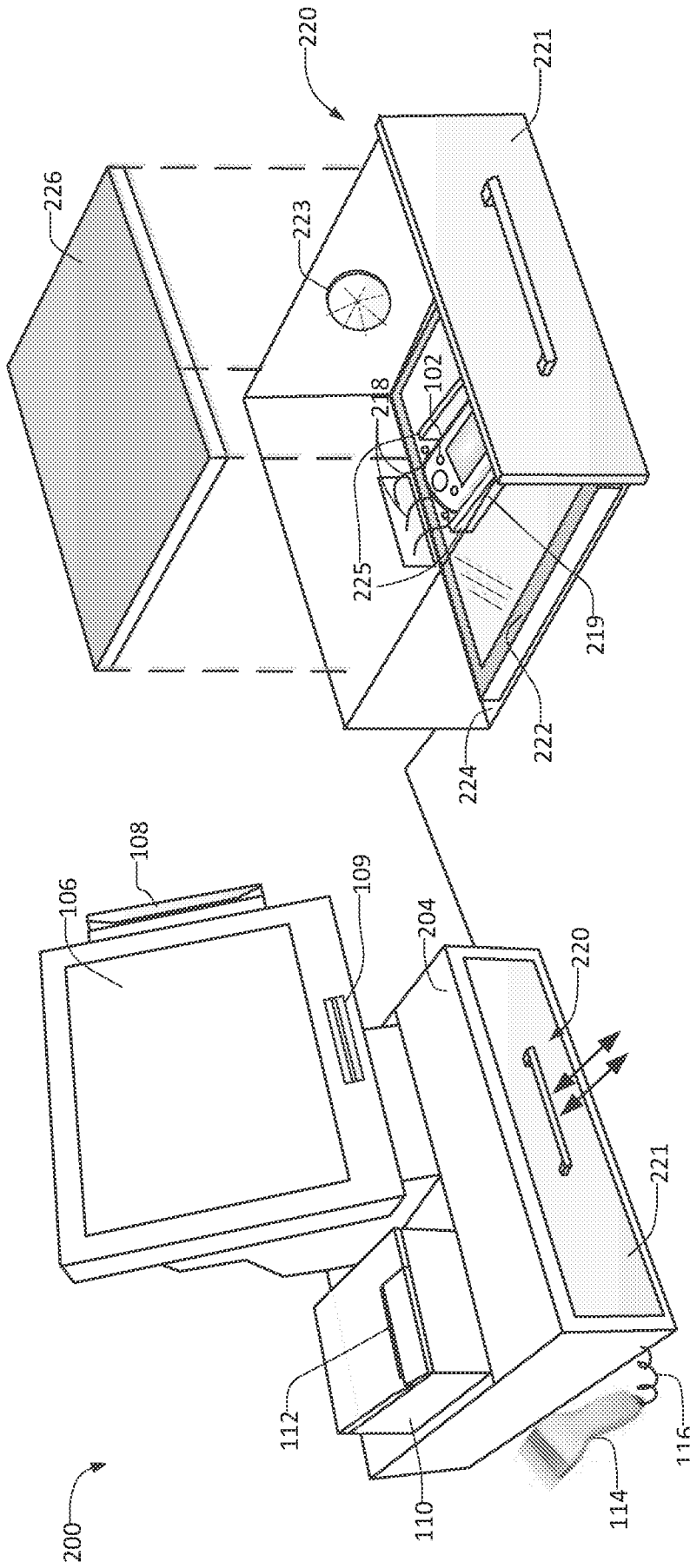

FIG. 2B

FIG. 2A

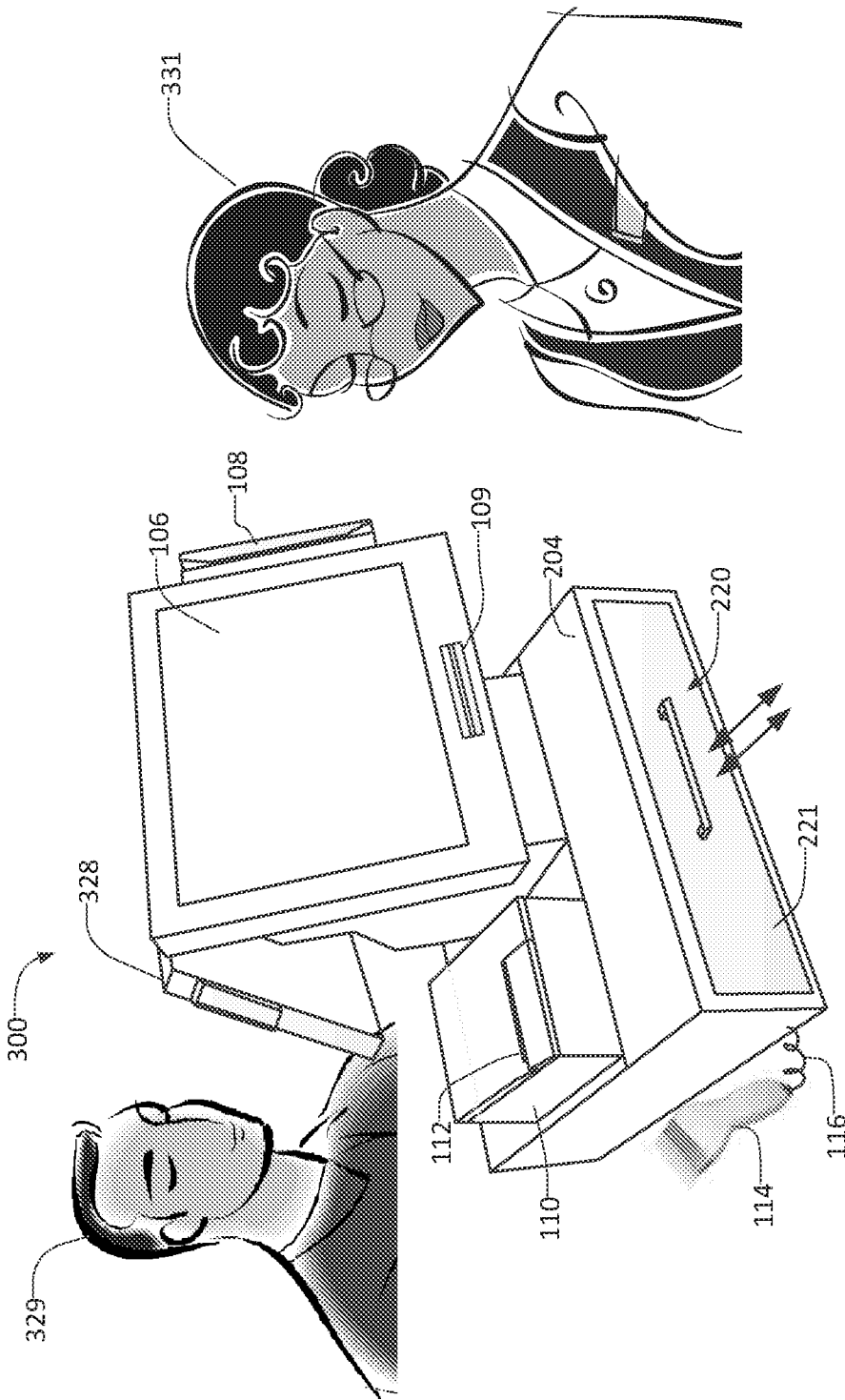

FIG. 3A

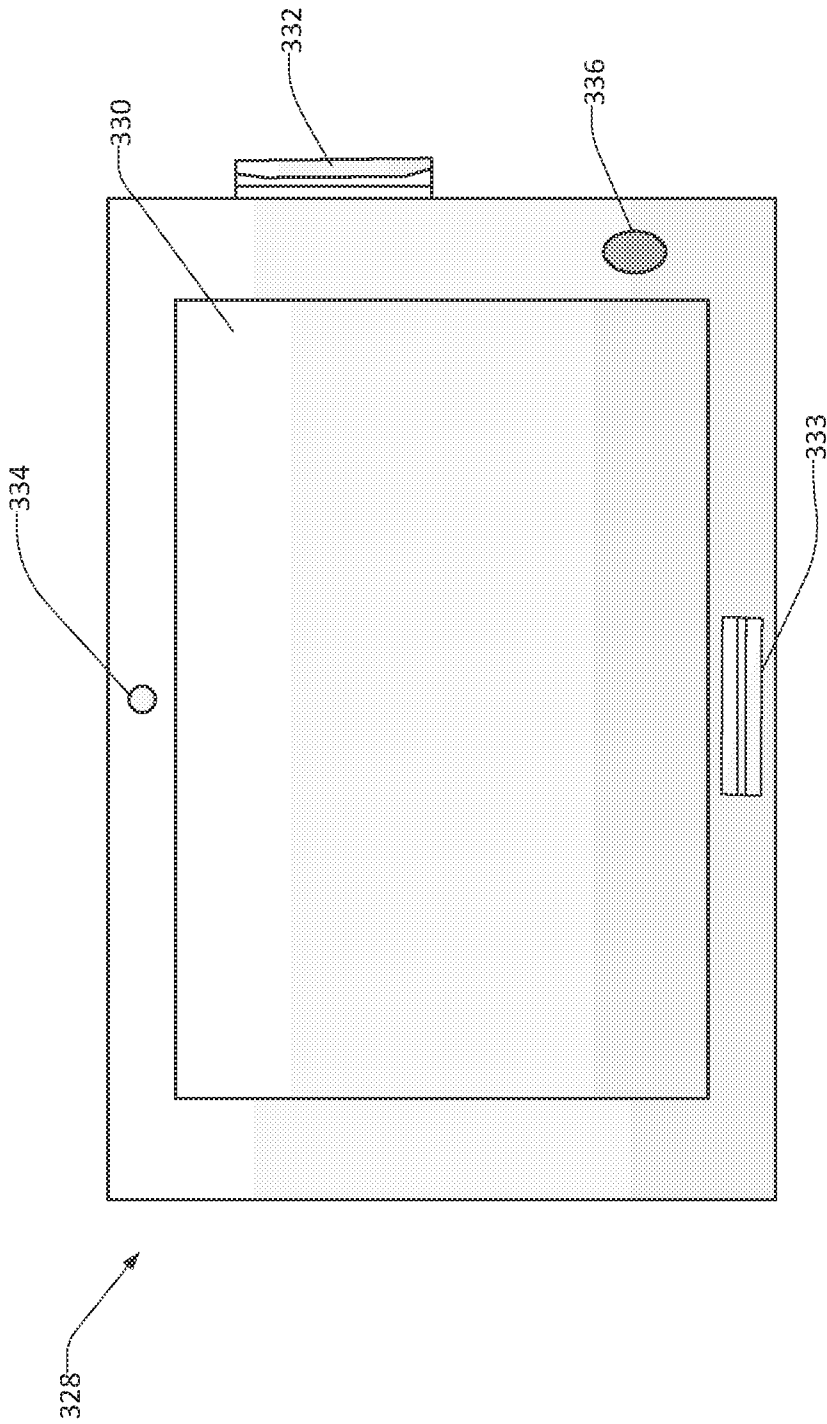

FIG. 3B

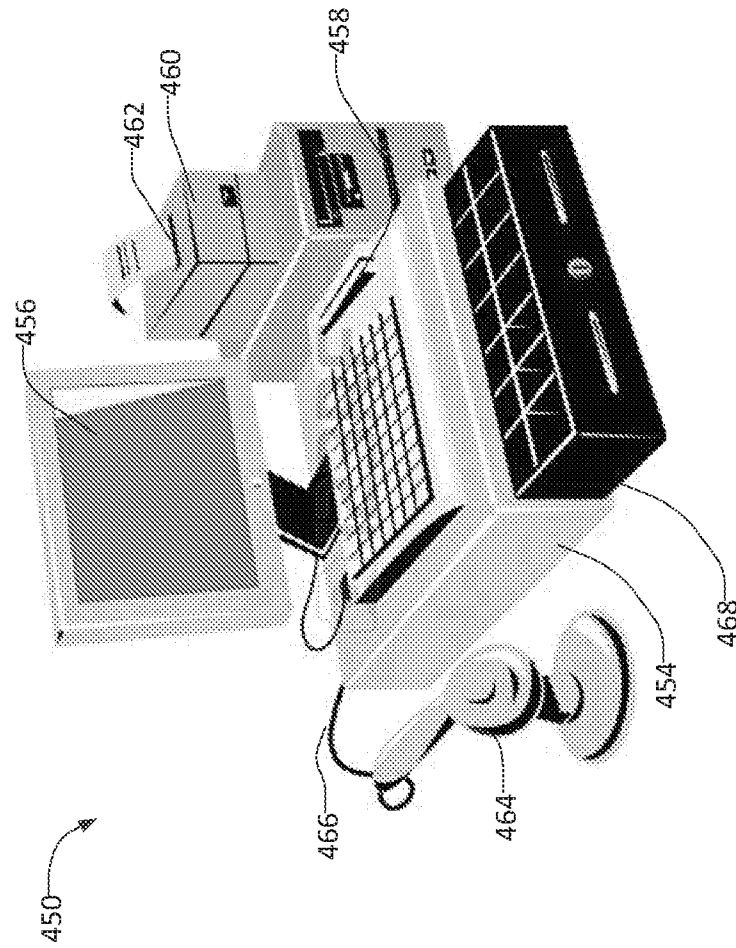
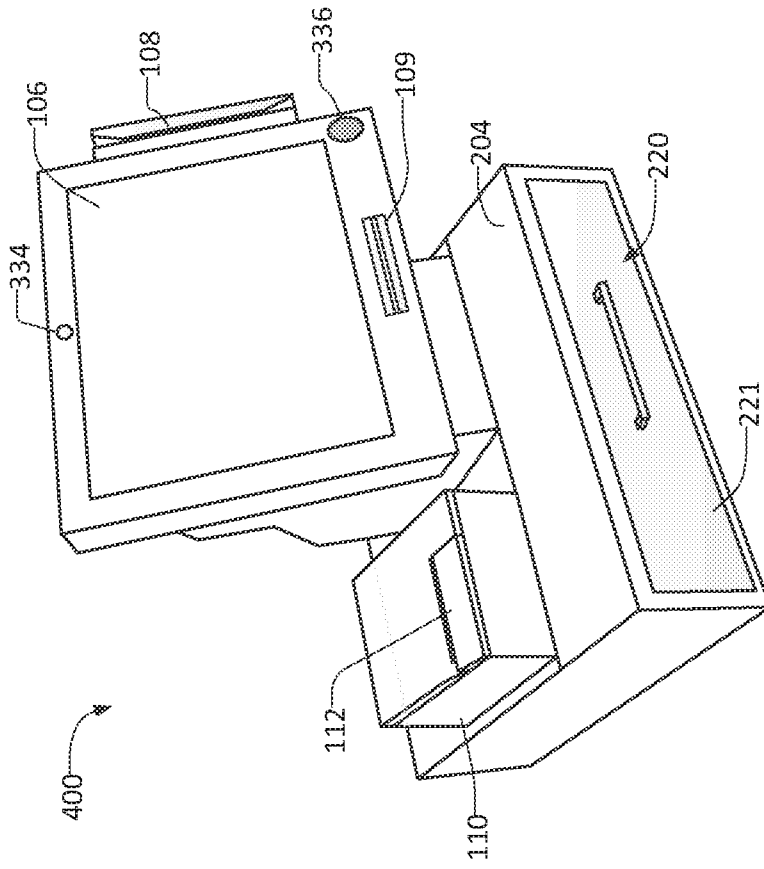

FIG. 4

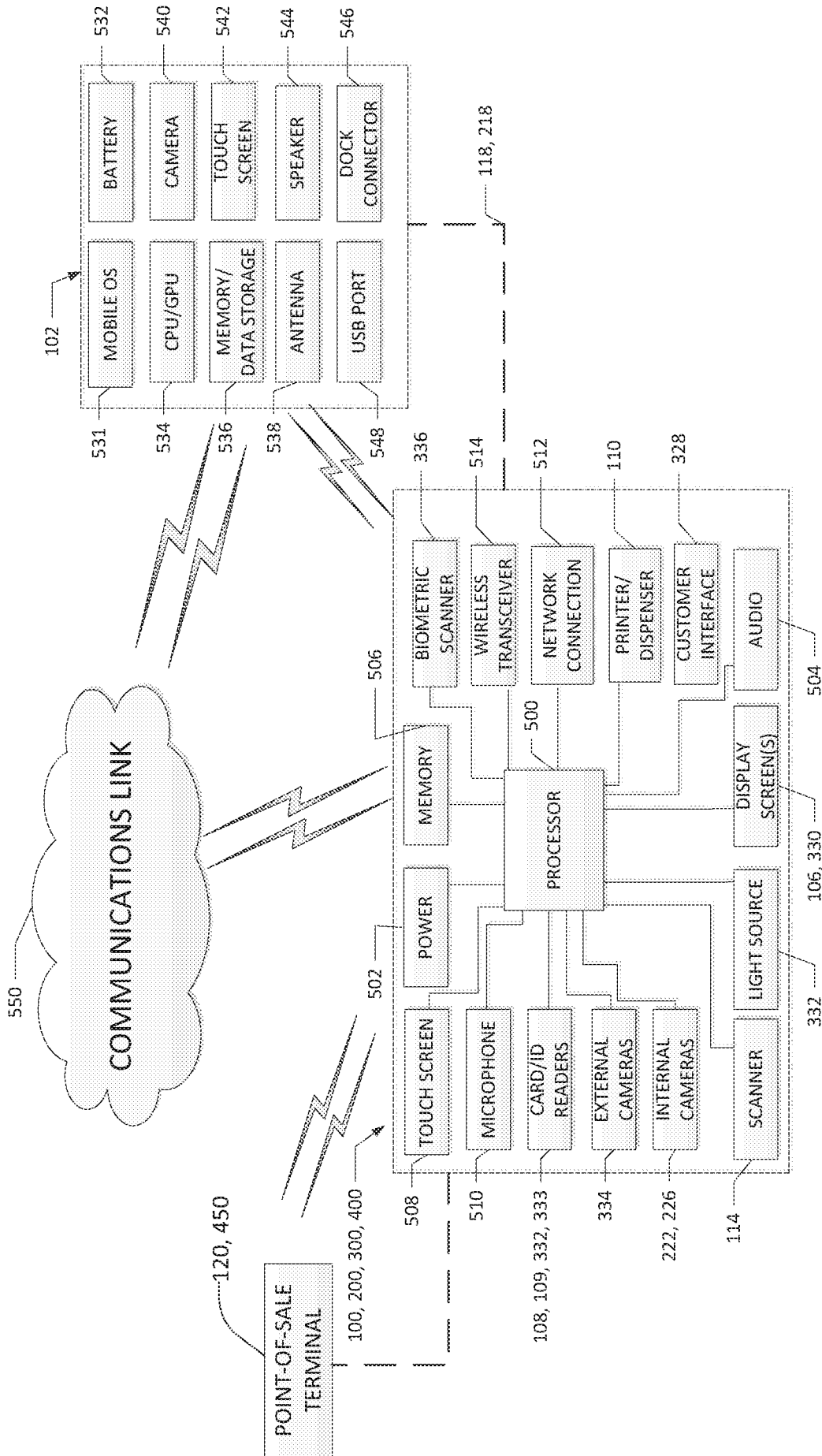

FIG. 5

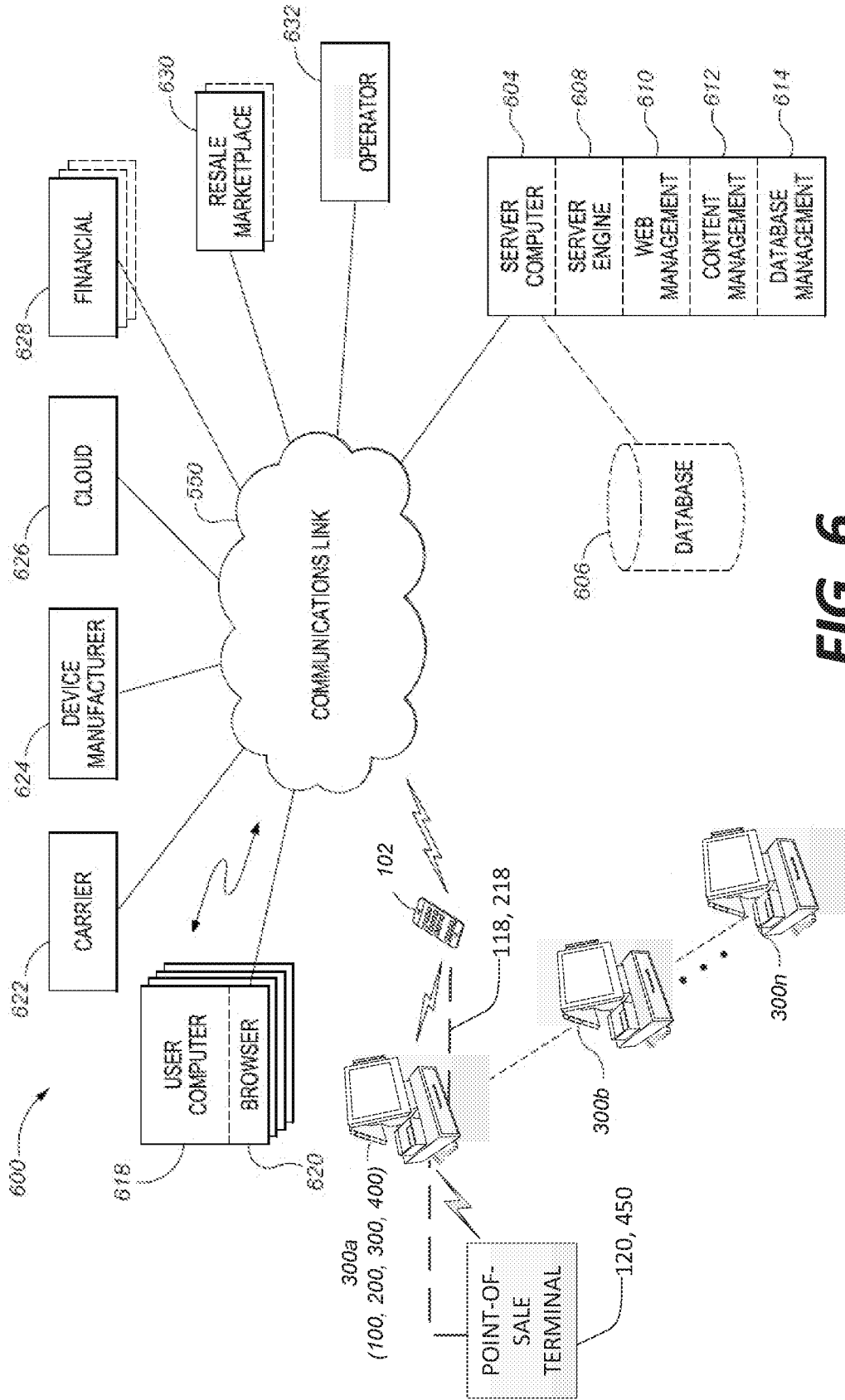

FIG. 6

INTERNATIONAL SEARCH REPORT

International application No
PCT/US2015/065226

A. CLASSIFICATION OF SUBJECT MATTER
INV. G06Q10/00 G06Q30/02
ADD.
According to International Patent Classification (IPC) or to both national classification and IPC

B. FIELDS SEARCHED
Minimum documentation searched (classification system followed by classification symbols)
G06Q
Documentation searched other than minimum documentation to the extent that such documents are included in the fields searched

Electronic data base consulted during the international search (name of data base and, where practicable, search terms used)
EPO-Internal, WPI Data

C. DOCUMENTS CONSIDERED TO BE RELEVANT

Category*	Citation of document, with indication, where appropriate, of the relevant passages	Relevant to claim No.
X	WO 2010/040116 A1 (BOWLES MARK [US]; VAN ROOYEN PIETER [US]; LIBRIZZI MICHAEL [US]) 8 April 2010 (2010-04-08) paragraph [0013] paragraph [0016] - paragraph [0022] paragraph [0025] paragraph [0029] - paragraph [0034] paragraph [0042] paragraph [0049] - paragraph [0050] paragraph [0054] - paragraph [0058] paragraph [0084] ----- -/--	1-37

Further documents are listed in the continuation of Box C.

See patent family annex.

* Special categories of cited documents :

<p>"A" document defining the general state of the art which is not considered to be of particular relevance</p> <p>"E" earlier application or patent but published on or after the international filing date</p> <p>"L" document which may throw doubts on priority claim(s) or which is cited to establish the publication date of another citation or other special reason (as specified)</p> <p>"O" document referring to an oral disclosure, use, exhibition or other means</p> <p>"P" document published prior to the international filing date but later than the priority date claimed</p>	<p>"T" later document published after the international filing date or priority date and not in conflict with the application but cited to understand the principle or theory underlying the invention</p> <p>"X" document of particular relevance; the claimed invention cannot be considered novel or cannot be considered to involve an inventive step when the document is taken alone</p> <p>"Y" document of particular relevance; the claimed invention cannot be considered to involve an inventive step when the document is combined with one or more other such documents, such combination being obvious to a person skilled in the art</p> <p>"&" document member of the same patent family</p>
---	---

Date of the actual completion of the international search 25 February 2016	Date of mailing of the international search report 03/03/2016
--	---

Name and mailing address of the ISA/ European Patent Office, P.B. 5818 Patentlaan 2 NL - 2280 HV Rijswijk Tel. (+31-70) 340-2040, Fax: (+31-70) 340-3016	Authorized officer Hanon, David
--	---

INTERNATIONAL SEARCH REPORT

 International application No
 PCT/US2015/065226

C(Continuation). DOCUMENTS CONSIDERED TO BE RELEVANT		
Category*	Citation of document, with indication, where appropriate, of the relevant passages	Relevant to claim No.
X	WO 2012/138679 A1 (ECOATM INC [US]) 11 October 2012 (2012-10-11) paragraph [0006] - paragraph [0008] paragraph [0016] paragraph [0043] - paragraph [0048] paragraph [0052] paragraph [0057] - paragraph [0058] paragraph [0063]	1-37
X	----- US 2010/169231 A1 (BOWLES MARK [US] ET AL) 1 July 2010 (2010-07-01) paragraph [0013] - paragraph [0015] paragraph [0041] - paragraph [0043] paragraph [0050] paragraph [0053] - paragraph [0055] -----	1-37

INTERNATIONAL SEARCH REPORT

Information on patent family members

International application No PCT/US2015/065226

Patent document cited in search report	Publication date	Patent family member(s)	Publication date
WO 2010040116	A1	08-04-2010	CA 2739633 A1 08-04-2010
			CN 102246384 A 16-11-2011
			CN 105303699 A 03-02-2016
			CN 105336044 A 17-02-2016
			CN 105336045 A 17-02-2016
			DE 202009019027 U1 21-09-2015
			EP 2335337 A1 22-06-2011
			JP 2012504832 A 23-02-2012
			JP 2015064888 A 09-04-2015
			US 2010088192 A1 08-04-2010
			US 2012246083 A1 27-09-2012
			US 2013275314 A1 17-10-2013
			WO 2010040116 A1 08-04-2010
WO 2012138679	A1	11-10-2012	CA 2832492 A1 11-10-2012
			CN 103765455 A 30-04-2014
			DE 202012013245 U1 14-09-2015
			EP 2695126 A1 12-02-2014
			JP 2014513829 A 05-06-2014
			US 2012191562 A1 26-07-2012
			WO 2012138679 A1 11-10-2012
US 2010169231	A1	01-07-2010	US 2010169231 A1 01-07-2010
			US 2011235853 A1 29-09-2011
			US 2012294490 A1 22-11-2012
			US 2013226679 A1 29-08-2013