



(72) GRIGOLON, Claudio Roberto, BR

(72) LUNA, Amauri Zanini, BR

(71) UNILEVER PLC, GB

(51) Int.Cl.⁶ C11D 17/00, C11D 3/39, C11D 3/37, B65D 75/36

(30) 1997/09/23 (9704788-0) BR

(54) **COMPOSITION DE NETTOYAGE POUR LAVE-VAISSELLE**

(54) **MACHINE DISH WASHING COMPOSITION**

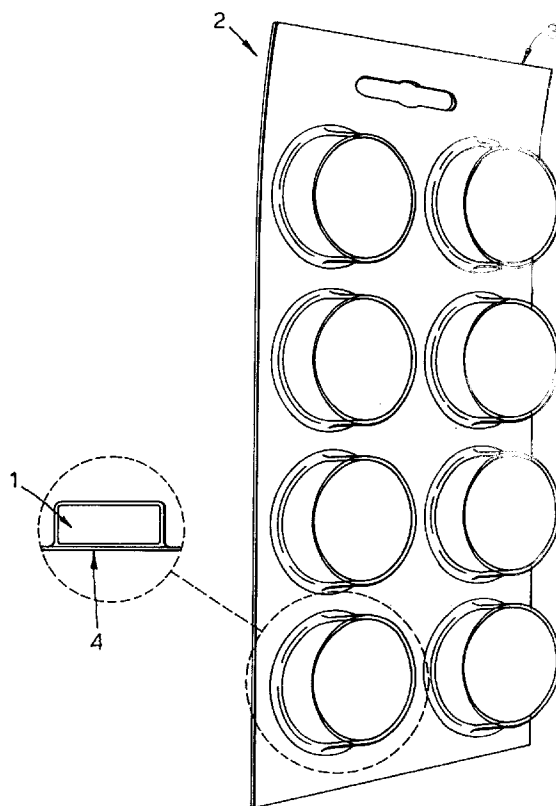

(57) Pastille de nettoyage pour lave-vaisselle, composée d'un produit de blanchiment, de silicone et de moins de 10 % en masse de surfactant. Un procédé de fabrication de cette pastille ainsi qu'un emballage servant à sa conservation et à son transport sont décrits dans le cadre de cette invention. Les pastilles se dissolvent rapidement et sont faciles à préparer.

(57) A machine dish washing tablet comprising a bleaching system, a silicone and less than 10 wt% of surfactant. A process is claimed for making this tablet and a pack is claimed for its storage and delivery. The tablets according to the invention have quick dissolution times and are easy to prepare.

Abstract

A machine dish washing tablet comprising a bleaching system, a silicone and less than 10 wt% of surfactant. A process is claimed for making this tablet and a pack is claimed for its storage and delivery. The tablets according to the invention have quick dissolution times and are easy to prepare.

Machine Dish Washing Composition

The present invention relates to a tablet for use in a dish
5 washing machine, a method of preparing the tablet and
packaging for the tablet.

Background of the Invention

10 Detergent tablets for dish-washing machines are liked by
consumers as they find them are more convenient to use than
alternative products such as powders and the like.

However detergent tablets frequently exhibit poor
15 dissolution rates in the washing water of the machine, this
poor dissolution can make it necessary for the consumer to
operate consecutive rinses which is time consuming.

Another problem that is faced is based on the fact that the
20 detergent tablets for dish-washing machines contain
formulations which are aggressive to the users' skin.

Tablets for machine dishwashing are described in
EP-A-224,128, EP-A-224,135 EP-A-224,136, WO-91/15568, and
25 EP-A-26,470. All the prior art primarily deals with
traditional high pH formulations and suggests routes to
improving the performance of tablets which basically rely on
modifying the solubility profiles of the tablets.

30 Powder flowability is an important factor to consider in the
manufacture of a tablet. Powders with a low flowability
(less than 50 ml/s) can have two negative aspects namely:

they can compact at the press feed line reducing throughput and they do not flow at a rate which is compatible with the pressing cycle and thus do not completely fill the tablet forming mold.

5

Another important factor to consider in the manufacture of a tablet is the powder's adherence to a punch's surface. If the surface of the punch retains any residual material, it can mark the next tablets to be produced, thus spoiling the smooth finish of the tablet.

10

Manufacture of tablets can also be difficult due to difficulty in ejecting the tablet from a mold.

This difficulty means that the mechanical wear on the tableting machine is increased and many flaws can occur on the tablet's surface.

15

To achieve tablets that are easy to process and quick to dissolve, detergent tablets may contain binding and disintegrating agents. An important property of these such agents is that they are compatible with the active ingredients in the tablet. Frequently an agent can have a dual role e.g., a binding agent also acts as a disintegrating agent.

25

Effervescent systems have been included in a tablet's formulation to increase their dissolution rate. Such effervescent systems include weak acids or acid salts such as citric acid, maleic acid, sodium and hydrogen phosphates, in combination with a basic ingredient that liberates carbon dioxide when interacting with this source of acid. Examples include sodium and potassium carbonate and bicarbonate and sodium sesquicarbonate.

30

Description of the Invention

The present invention relates to a tablet that dissolves rapidly when added to water and is easy to manufacture
5 accordingly the present invention relates to a machine dish washing tablet comprising a bleaching system, a silicone and less than 10 wt% of surfactant.

The invention also relates to a process for preparing
10 machine dish washing tablets comprising the step of adding a silicone emulsion to a formulation that is to be tableted.

The invention also relates to a dish washing tablet(1) and a packaging system (2) the packaging system comprising a body
15 (3) shaped to receive a tablet and a cover(4) which keeps the tablet in the body. The use of this packaging system to store dish washing tablet is also described.

Detailed description of the Invention

20 The tablets according to the present invention not only dissolve quickly in the dish washing machine but they are easy to process in that the powder used to manufacture the tablets has good flowability, does not adhere to the punch's
25 surface and the tablets produced are easily ejected from the mold.

Additionally the tablets of the invention can be prepared by conventional presses instead of powerful presses which are
30 commonly used to for making detergent tablets.

Conventional presses are those with engines with up to 5hp, a sole compression stage with a working capacity of up to

12t/cm² and production rate of 18000 tablets per hour. The cost of these presses is up to 8 times smaller than the double-stage large presses with a high pressing rate normally used to prepare detergent tablets.

5

Silicones

The tablets of the invention comprise a silicone, preferably in the form of an emulsion.

10

The addition of water to the tablet via the emulsion is beneficial because it can prevent the powder from granulating. The granulation of the powder to from granules greater than 10mm is undesirable because it causes difficulties when press feeding press feeding.

15

The silicones used are preferably polymers or copolymers of dimethyl silicone or aminomethoxy functionalised dimethyl silicone. Mixtures of the polymers may also be used.

20

It is preferable if the level of silicone emulsion added to the product is from 0.5 wt% to 10 wt% of the total product, preferably from 1 to 3 wt%.

25

It is also preferable if the level of silicone within the silicone emulsion is from 2 wt% to 50 wt% of the total weight of the silicone emulsion, preferably from 5 to 15 wt%.

30

To emulsify the silicone in water any emulsifier may be used, preferably the emulsifier is a surfactant, most preferred as the emulsifier a nonionic surfactant.

The silicone emulsions preferentially used in the present invention are those available from Dow Corning under the trademarks Dow Corning 36, 346, and 347; Dow Corning HV-490, 5 Dow Corning 190 and 93; Dow Corning 531 and 536; Dow Corning 8075, 7242, Dow Corning 2-8707 and OSI-SAG 470,

Bleaching Systems

10 The bleaching systems of the invention are preferably oxygen based.

Peroxy Bleaching Agents

The oxygen bleaching agents of the compositions include 15 organic peroxy acids and diacylperoxides. Typical monoperoxy acids useful herein include alkyl peroxy acids and aryl peroxy acids such as:

I) peroxybenzoic acid and ring-substituted peroxybenzoic 20 acids, e.g., peroxy-alpha-naphthoic acid, and magnesium monoperoxyphthalate

ii) aliphatic and substituted aliphatic monoperoxy acids, 25 e.g., peroxy lauric acid, peroxy stearic acid, epsilon-phthalimido-peroxyhexanoic acid and o-carboxybenzamido peroxyhexanoic acid, N-nonylamidoperadipic acid and N-nonylamido-persuccinic acid.

30 iii) Cationic peroxyacids such as those described in US-A-5,422,028, US-A-5,294,362; and US-A-5,292,447.

iv) Sulfonyl peroxyacids such as compounds described in US-A-5,039,447 (Monsanto Co.).

Typical diperoxy acids useful herein include alkyl diperoxy acids and aryl diperoxy acids, such as:

- v) 1,12-diperoxydodecanedioic acid
- 5 vi) 1,9-diperoxyazelaic acid
- vii) diperoxybrassylic acid; diperoxysecacic acid and
diperoxy-isophthalic acid
- viii) 2-decyldiperoxybutan-1,4-dioic acid
- ix) N,N¹-terephthaloyl-di(6-aminopercaproic acid).

10

A typical diacylperoxide useful herein includes dibenzoylperoxide.

Inorganic peroxygen compounds are especially suitable for
15 the present invention. Examples of these materials useful
in the invention are salts of monopersulfate, perborate
monohydrate, perborate tetrahydrate, and percarbonate.
sodium perborate and sodium percarbonate are particularly
preferred.

20

The organic peroxy acid is present in the composition in an
amount such that the level of organic peroxy acid in the
wash solution is 1 ppm to 300 ppm AvOx, preferably 2 ppm to
200 ppm AvOx. Typical levels of organic peroxy acid are
25 from 2 wt% to 15 wt% of the total formulation.

The oxygen bleaching agent may be incorporated directly into
the formulation or may be encapsulated by any number of
encapsulation techniques.

30

Bleach Precursors

Suitable peracid precursors for peroxy bleach compounds have been amply described in the literature, including GB Nos.

5 836,988; 855,735; 907,356; 907,358; 907,950; 1,003,310 and 1,246,339; US-A-3,332,882 and US-A-4,128,494.

Typical examples of precursors are polyacylated alkylene diamines, such as N,N,N',N'-tetraacetylene diamine
10 (TAED) and N,N,N',N'-tetraacetylmethylene diamine (TAMD); acylated glycolurils, such as tetraacetyl glycoluril (TAGU); triacetylcyanurate, sodium sulfophenyl ethyl carbonic acid ester, sodium acetyloxybenzene sulfonate (SABS), sodium nonanoyloxy benzene sulfonate (SNOBS) and choline

15 sulfophenyl carbonate. Peroxybenzoic acid precursors are known in the art, e.g., as described in GB-A-836,988.

Examples of suitable precursors are phenylbenzoate; phenyl p-nitrobenzoate; o-nitrophenyl benzoate; o-carboxyphenyl benzoate; p-bromophenylbenzoate; sodium or potassium
20 benzoyloxy benzene-sulfonate; and benzoic anhydride.

Preferred peroxygen bleach precursors are sodium p-benzoyloxybenzene sulfonate, N,N,N',N'-tetraacetylene diamine, sodium nonanoyloxybenzene sulfonate and choline
25 sulfophenyl carbonate. The peroxygen bleach precursors may be present in the composition in an amount from 1 to 20 wt. %, preferably from 1 to 15 wt. %, most preferably from 2 to 10 weight %. To deliver a functional peroxygen bleach from a precursor, a source of hydrogen peroxide is required. The
30 hydrogen peroxide source is preferably a compound that delivers hydrogen peroxide on dissolution. Preferred sources of hydrogen peroxide are sodium perborate, either as mono- or tetrahydrate and sodium percarbonate. The source

of hydrogen peroxide, when included in the composition, is present at a level from 1% to 30% by weight, preferably from 2% to 25% by weight, most preferably from 4% to 20% by weight.

5

Bleach Catalyst

An effective amount of a bleach catalyst can also be present in the first layer. A number of organic catalysts are available such as the sulfonimines as described in US-A-10 5,041,232; US-A-5,047,163 and US-A-5,463,115.

Transition metal bleach catalysts are also useful especially those based on manganese, iron, cobalt, titanium, 15 molybdenum, nickel, chromium, copper, ruthenium, tungsten and mixtures thereof. These include simple water-soluble salts such as those of iron, manganese and cobalt as well as catalysts containing complex ligands.

20 Suitable examples of manganese catalysts containing organic ligands are described in US-A-4,728,455, US-A-5,114,606, US-A-5,153,161, US-A-5,194,416, US-A-5,227,084, US-A-5,244,594, US-A-5,246,612, US-A-5,246,621, US-A-5,256,779, US-A-5,274,147, US-A-5,280,117 and EP-A-544,440, EP-A-544,490, 25 EP-A-549,271 and EP-A-549,272. Preferred examples of these catalysts include $\text{Mn}^{\text{IV}}_2(\text{u-O})_2(1,4,7\text{-trimethyl-1,4,7-triazacyclononane})_2(\text{PF}_6)_2$, $\text{Mn}^{\text{III}}_2(\text{u-O})_1(\text{u-OAc})_2(1,4,7\text{-trimethyl-1,4,7-triazacyclononane})_2(\text{ClO}_4)_2$, $\text{Mn}^{\text{IV}}_4(\text{u-O})_6(1,4,7\text{-trimethyl-1,4,7-triazacyclononane})_4(\text{ClO}_4)_4$, $\text{Mn}^{\text{III}}\text{Mn}^{\text{IV}}_4(\text{u-O})_1(\text{u-OAc})_2(1,4,7\text{-trimethyl-1,4,7-triazacyclononane})_2(\text{ClO}_4)_3$, $\text{Mn}^{\text{IV}}(1,4,7\text{-trimethyl-1,4,7-triazacyclononane})-$ 30

(OCH₃)₃(PF₆), and mixtures thereof. Other metal-based bleach catalysts include those disclosed in US-A-4,430,243 and US-A-5,114,611.

5 Iron and manganese salts of aminocarboxylic acids in general are useful herein including iron and manganese aminocarboxylate salts disclosed for bleaching in the photographic color processing arts. A particularly useful transition metal salt is derived from ethylenediaminedisuccinate and any complex of this ligand
10 with iron or manganese.

Another type of bleach catalyst, as disclosed in US-A-5,114,606 is a water soluble complex of manganese (II), (III), and/or (IV) with a ligand which is a non-carboxylate
15 polyhydroxy compound having at least three consecutive C-OH groups. Preferred ligands include sorbitol, iditol, dulcitol, mannitol, xylitol, arabitol, adonitol, meso-erythritol, meso-inositol, lactose and mixtures thereof. Especially preferred is sorbitol.

20 US-A-5,114,611 teaches a bleach catalyst comprising a complex of transition metals, including manganese, cobalt, iron or copper with an non-(macro)-cyclic ligand. Other examples include Mn gluconate, Mn(CF₃SO₃)₂, and binuclear Mn complexed with tetra-N-dentate and bi-N-dentate ligands,
25 including [bipy₂Mn^{III}(u-O)₂Mn^{IV}bipy₂](ClO₄)₃.

Other bleach catalysts are described, for example, in EP-A-408,131 (cobalt complexes), EP-A-384,503 and EP-A-306,089
30 (metallo-porphyrins), US-A-4,728,455 (manganese/multidentate ligand), US-A-4,711,748 (absorbed manganese on aluminosilicate), US-A-4,601,845 (aluminosilicate support with manganese, zinc or magnesium salt), US-A-4,626,373

(manganese/ligand), US-A-4,119,557 (ferric complex), US-A-4,430,243 (Chelants with manganese cations and non-catalytic metal cations), and US-A-4,728,455 (manganese gluconates).

5 Useful catalysts based on cobalt are described in WO96/23859, WO96/23860 and WO96/23861 and US-A-5,559,261. WO 96/23860 describe cobalt catalysts of the type $[\text{Co}_n\text{L}_m\text{X}_p]^z\text{Y}_z$, where L is an organic ligand molecule containing more than one heteroatom selected from N, P, O and S; X is a
10 co-ordinating species; n is preferably 1 or 2; m is preferably 1 to 5; p is preferably 0 to 4 and Y is a counterion. One example of such a catalyst is N,N'-Bis(salicylidene)ethylenediaminecobalt (II). Other cobalt catalysts described in these applications are based on
15 Co(III) complexes with ammonia and mon-, bi-, tri- and tetradentate ligands such as $[\text{Co}(\text{NH}_3)_5\text{OAc}]^{2+}$ with Cl^- , OAc^- , PF_6^- , SO_4^- , BF_4^- anions.

Certain transition-metal containing bleach catalysts can be
20 prepared in the situ by the reaction of a transition-metal salt with suitable chelating agent, for example, a mixture of manganese sulfate and ethylenediaminedisuccinate. Highly colored transition metal-containing bleach catalysts may be co-processed with zeolites to reduce the color impact.

25 When present, the bleach catalyst is typically incorporated at a level of 0.0001 to 10% by wt., preferably 0.001 to 5% by weight.

Detergent Builder Material

The compositions of this invention can contain all manner of detergent builders commonly taught for use in machine
5 dishwashing or other cleaning compositions. The builders can include any of the conventional inorganic and organic water-soluble builder salts, or mixtures thereof and comprise 5 to 90% by weight, preferably from 10 to 80% by weight of the cleaning composition.

10

Typical examples of phosphorus-containing inorganic builders, when present, include the water-soluble salts, especially alkali metal pyrophosphates, orthophosphates and polyphosphates. Specific examples of inorganic phosphate
15 builders include sodium and potassium tripolyphosphates, pyrophosphates and hexametaphosphates.

Suitable examples of non-phosphorus-containing inorganic builders, when present, include water-soluble alkali metal
20 carbonates, bicarbonates, sesquicarbonates, borates, silicates, including layered silicates such as SKS-6 ex. Hoechst, metasilicates, and crystalline and amorphous aluminosilicates. Specific examples include sodium carbonate (with or without calcite seeds), potassium
25 carbonate, sodium and potassium bicarbonates, silicates including layered silicates and zeolites.

Organic detergent builders can also be used in the present invention. Examples of organic builders include alkali
30 metal citrates, succinates, malonates, fatty acid sulfonates, fatty acid carboxylates, nitrilotriacetates, phytates, phosphonates, alkanhydroxyphosphonates, oxydisuccinates, alkyl and alkenyl disuccinates,

- 12 -

oxydiacetates, carboxymethyloxy succinates, ethylenediamine tetraacetates, tartrate monosuccinates, tartrate disuccinates, tartrate monoacetates, tartrate diacetates, oxidized starches, oxidized heteropolymeric polysaccharides, 5 polyhydroxysulfonates, polycarboxylates such as polyacrylates, polymaleates, polyacetates, polyhydroxyacrylates, polyacrylate/polymaleate and polyacrylate/ polymethacrylate copolymers, acrylate/maleate/vinyl alcohol terpolymers, 10 aminopolycarboxylates and polyacetal carboxylates, and polyaspartates and mixtures thereof. Such carboxylates are described in US-A-4,144,226, US-A-4,146,495 and US-A-4,686,062.

15 Alkali metal citrates, nitrilotriacetates, oxydisuccinates, polyphosphonates, acrylate/maleate copolymers and acrylate/maleate/vinyl alcohol terpolymers are especially preferred organic builders.

20 Buffering System

The buffering system may be present in order to deliver a pH of about 6 to about 11 in the wash water. Materials which may be selected for the buffering system include 25 water-soluble alkali metal carbonates, bicarbonates, sesquicarbonates, borates, silicates, layered silicates such as SKS-6 ex Hoechst, metasilicates, phytic acid, citric acid, borate and crystalline and amorphous aluminosilicates and mixtures thereof. Preferred examples include sodium and 30 potassium carbonate, sodium and potassium bicarbonates, borates and silicates, including layered silicates

Surfactants

Optionally a surfactant may be included in the tablet including anionic, nonionic, cationic, amphoteric, zwitteronic surfactants and mixtures of these surface active agents. However the total level of surfactant in the tablet must not exceed 10% by weight of the total weight of the tablet. Such surfactants are well known in the detergent arts and are described at length at "Surface Active Agents and Detergents", Vol. 2 by Schwartz, Perry and Birch, Interscience Publishers, Inc., 1959, herein incorporated by reference.

Preferred surfactants are one or a mixture of:

15

Anionic surfactants

Anionic synthetic detergents can be broadly described as surface active compounds with one or more negatively charged functional groups. An important class of anionic compounds are the water-soluble salts, particularly the alkali metal salts, of organic sulfur reaction products having in their molecular structure an alkyl radical containing from about 6 to 24 carbon atoms and a radical selected from the group consisting of sulfonic and sulfuric acid ester radicals.

25

Primary Alkyl Sulfates



where R^1 is a primary alkyl group of 8 to 18 carbon atoms and M is a solubilizing cation. The alkyl group R^1 may have a mixture of chain lengths. It is preferred that at least two thirds of the R^1 alkyl groups have a chain length of 8 to 14

30

carbon atoms. This will be the case if R^1 is coconut alkyl, for example. The solubilizing cation may be a range of cations which are in general monovalent and confer water solubility. Alkali metal, notably sodium, is especially envisaged. Other possibilities are ammonium and substituted ammonium ions, such as trialkanolammonium or trialkylammonium.

Alkyl Ether Sulfates

10

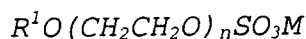

where R^1 is a primary alkyl group of 8 to 18 carbon atoms, n has an average value in the range from 1 to 6 and M is a solubilizing cation. The alkyl group R^1 may have a mixture of chain lengths. It is preferred that at least two thirds of the R^1 alkyl groups have a chain length of 8 to 14 carbon atoms. This will be the case if R^1 is coconut alkyl, for example. Preferably n has an average value of 2 to 5.

20

Fatty Acid Ester Sulfonates

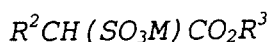

where R^2 is an alkyl group of 6 to 16 atoms, R^3 is an alkyl group of 1 to 4 carbon atoms and M is a solubilizing cation. The group R^2 may have a mixture of chain lengths. Preferably at least two thirds of these groups have 6 to 12 carbon atoms. This will be the case when the moiety $R^2CH(-)CO_2(-)$ is derived from a coconut source, for instance. It is preferred that R^3 is a straight chain alkyl, notably methyl or ethyl.

30

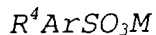
Alkyl Benzene Sulfonates

5 where R^4 is an alkyl group of 8 to 18 carbon atoms, Ar is a benzene ring (C_6H_4) and M is a solubilizing cation. The group R^4 may be a mixture of chain lengths. Straight chains of 11 to 14 carbon atoms are preferred.

10 *Paraffin sulfonates* having 8 to 22 carbon atoms, preferably 12 to 16 carbon atoms, in the alkyl moiety. These surfactants are commercially available as Hostapur SAS from Hoechst Celanese.

15 *Olefin sulfonates* having 8 to 22 carbon atoms, preferably 12 to 16 carbon atoms. U.S. Patent No. 3,332,880 contains a description of suitable olefin sulfonates.

Organic phosphate based anionic surfactants include organic
20 phosphate esters such as complex mono- or diester phosphates of hydroxyl- terminated alkoxide condensates, or salts thereof. Included in the organic phosphate esters are phosphate ester derivatives of polyoxyalkylated alkylaryl phosphate esters, of ethoxylated linear alcohols and
25 ethoxylates of phenol. Also included are nonionic alkoxyates having a sodium alkylencarboxylate moiety linked to a terminal hydroxyl group of the nonionic through an ether bond. Counterions to the salts of all the
30 foregoing may be those of alkali metal, alkaline earth metal, ammonium, alkanolammonium and alkylammonium types.

- 16 -

Particularly preferred anionic surfactants are the fatty acid ester sulfonates with formula:

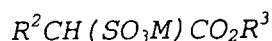

5

where the moiety $R^2CH(-)CO_2(-)$ is derived from a coconut source and R^3 is either methyl or ethyl; primary alkyl sulfates with the formula:

10



wherein R^1 is a primary alkyl group of 10 to 18 carbon atoms and M is a sodium cation; and paraffin sulfonates, preferably with 12 to 16 carbon atoms to the alkyl moiety.

15

Nonionic surfactants

Nonionic surfactants can be broadly defined as surface active compounds with one or more uncharged hydrophilic substituents. A major class of nonionic surfactants are those compounds produced by the condensation of alkylene oxide groups with an organic hydrophobic material which may be aliphatic or alkyl aromatic in nature. The length of the hydrophilic or polyoxyalkylene radical which is condensed with any particular hydrophobic group can be readily adjusted to yield a water-soluble compound having the desired degree of balance between hydrophilic and hydrophobic elements. Illustrative, but not limiting examples, of various suitable nonionic surfactant types are:

30

polyoxyalkene condensates of aliphatic carboxylic acids, whether linear- or branched-chain and unsaturated or saturated, especially ethoxylated and/or propoxylated

aliphatic acids containing from about 8 to about 18 carbon atoms in the aliphatic chain and incorporating from about 2 to about 50 ethylene oxide and/or propylene oxide units. Suitable carboxylic acids include "coconut" fatty acids (derived from coconut oil) which contain an average of about 12 carbon atoms, "tallow" fatty acids (derived from tallow-class fats) which contain an average of about 18 carbon atoms, palmitic acid, myristic acid, stearic acid and lauric acid,

10

polyoxyalkene condensates of aliphatic alcohols, whether linear- or branched-chain and unsaturated or saturated, especially ethoxylated and/or propoxylated aliphatic alcohols containing from about 6 to about 24 carbon atoms and incorporating from about 2 to about 50 ethylene oxide and/or propylene oxide units. Suitable alcohols include "coconut" fatty alcohol, "tallow" fatty alcohol, lauryl alcohol, myristyl alcohol and oleyl alcohol.

15

20 Ethoxylated fatty alcohols may be used alone or in admixture with anionic surfactants, especially the preferred surfactants above. The average chain lengths of the alkyl group R^5 in the general formula:

25

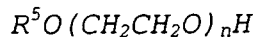

is from 6 to 20 carbon atoms. Notably the group R^5 may have chain lengths in a range from 9 to 18 carbon atoms.

30

The average value of n should be at least 2. The numbers of ethylene oxide residues may be a statistical distribution around the average value. However, as is known, the distribution can be affected by the manufacturing process or

altered by fractionation after ethoxylation. Particularly preferred ethoxylated fatty alcohols have a group R^5 which has 9 to 18 carbon atoms while n is from 2 to 8.

- 5 Also included within this category are nonionic surfactants having a formula:



- 10 wherein R^6 is a linear alkyl hydrocarbon radical having an average of 6 to 18 carbon atoms, R^7 and R^8 are each linear alkyl hydrocarbons of about 1 to about 4 carbon atoms, x is an integer of from 1 to 6, y is an integer of from 4 to 20 and z is an integer from 4 to 25.

15

- One preferred nonionic surfactant of the above formula is Poly-Tergent SLF-18⁷ a registered trademark of the Olin Corporation, New Haven, Conn. having a composition of the above formula where R^6 is a C₆-C₁₀ linear alkyl mixture, R^7 and R^8 are methyl, x averages 3, y averages 12 and z averages 16. Another preferred nonionic surfactant is

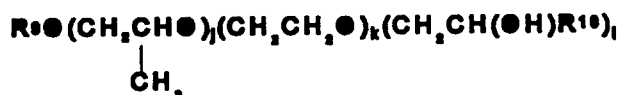

- wherein R^9 is a linear, aliphatic hydrocarbon radical having from about 4 to about 18 carbon atoms including mixtures thereof; and R^{10} is a linear, aliphatic hydrocarbon radical
- 25

having from about 2 to about 26 carbon atoms including mixtures thereof; j is an integer having a value of from 1 to about 3; k is an integer having a value from 5 to about 30; and z is an integer having a value of from 1 to about 3.

5 Most preferred are compositions in which j is 1, k is from about 10 to about 20 and l is 1. These surfactants are described in WO 94/22800. Other preferred nonionic surfactants are linear fatty alcohol alkoxyates with a capped terminal group, as described in U.S. 4,340,766

10 to BASF. Particularly preferred is Plurafac LF403 ex. BASF.

Another nonionic surfactant included within this category are compounds of formula:



15 wherein R^{11} is a C_6 - C_{24} linear or branched alkyl hydrocarbon radical and q is a number from 2 to 50; more preferably R^{11} is a C_8 - C_{18} linear alkyl mixture and q is a number from 2 to 15.

20 *polyoxyethylene or polyoxypropylene condensates of alkyl phenols*, whether linear- or branched-chain and unsaturated or saturated, containing from about 6 to 12 carbon atoms and incorporating from about 2 to about 25 moles of ethylene oxide and/or propylene oxide.

25 *polyoxyethylene derivatives of sorbitan mono-, di-, and tri-fatty acid esters* wherein the fatty acid component has between 12 and 24 carbon atoms. The preferred polyoxyethylene derivatives are of sorbitan monolaurate,

30 sorbitan trilaurate, sorbitan monopalmitate, sorbitan tripalmitate, sorbitan monostearate, sorbitan monoisostearate, sorbitan tripalmitate, sorbitol

tristearate, sorbitan monooleate, and sorbitan trioleate. The polyoxyethylene chains may contain between about 4 and 30 ethylene oxide units, preferably about 10 to 20. The sorbitan ester derivatives contain 1, 2 or 3 polyoxyethylene chains dependent upon whether they are mono-, di- or tri-acid esters.

polyoxyethylene-polyoxypropylene block copolymers having formula:

10

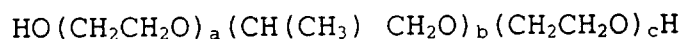

or

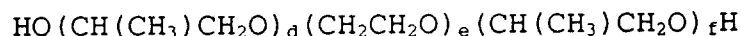

15 wherein a, b, c, d, e and f are integers from 1 to 350 reflecting the respective polyethylene oxide and polypropylene oxide blocks of said polymer. The polyoxyethylene component of the block polymer constitutes at least about 10% of the block polymer. The material preferably has a molecular weight of between about 1,000 and 20 15,000, more preferably from about 1,500 to about 6,000. These materials are well-known in the art. They are available under the trademark "Pluronic" and "Pluronic R", a product of BASF Corporation.

25

Amine oxides having formula:

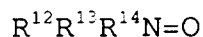

30 wherein R^{12} , R^{13} and R^{14} are saturated aliphatic radicals or substituted saturated aliphatic radicals. Preferable amine oxides are those wherein R^{12} is an alkyl chain of

about 10 to about 20 carbon atoms and R¹³ and R¹⁴ are methyl or ethyl groups or both R¹² and R¹³ are alkyl chains of about 6 to about 14 carbon atoms and R¹⁴ is a methyl or ethyl group.

5

Amphoteric synthetic detergents can be broadly described as derivatives of aliphatic tertiary amines, in which the aliphatic radical may be straight chain or branched and wherein one of the aliphatic substituents contain from about 8 to about 18 carbons and one contains an anionic water-solubilizing group, i.e., carboxy, sulpho, sulphato, phosphato or phosphono. Examples of compounds falling within this definition are sodium 3-dodecylamino propionate and sodium 2-dodecylamino propane sulfonate.

15

Zwitterionic synthetic detergents can be broadly described as derivatives of aliphatic quaternary ammonium, phosphonium and sulphonium compounds in which the aliphatic radical may be straight chained or branched, and wherein one of the aliphatic substituents contains from about 8 to about 18 carbon atoms and one contains an anionic water-solubilizing group, e.g., carboxy, sulpho, sulphato, phosphato or phosphono. These compounds are frequently referred to as betaines. Besides alkyl betaines, alkyl amino and alkyl amido betaines are encompassed within this invention.

25

Alkyl Glycosides

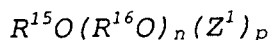

wherein R¹⁵ is a monovalent organic radical (e.g., a monovalent saturated aliphatic, unsaturated aliphatic or aromatic radical such as alkyl, hydroxyalkyl, alkenyl, hydroxyalkenyl, aryl, alkylaryl, hydroxyalkylaryl, arylalkyl, alkenylaryl, arylalkenyl, etc.) containing from

30

- 22 -

about 6 to about 30 (preferably from about 8 to 18 and more preferably from about 9 to about 13) carbon atoms; R^{16} is a divalent hydrocarbon radical containing from 2 to about 4 carbon atoms such as ethylene, propylene or butylene (most preferably the unit $(R^{16}O)_n$ represents repeating units of ethylene oxide, propylene oxide and/or random or block combinations thereof); n is a number having an average value of from 0 to about 12; Z^1 represents a moiety derived from a reducing saccharide containing 5 or 6 carbon atoms (most preferably a glucose unit); and p is a number having an average value of from 0.5 to about 10 preferably from about 0.5 to about 5.

Examples of commercially available materials from Henkel Kommanditgesellschaft Aktien of Dusseldorf, Germany include APG⁷ 300, 325 and 350 with R^{15} being C_9-C_{11} , n is 0 and p is 1.3, 1.6 and 1.8-2.2 respectively; APG⁷ 500 and 550 with R^{15} is $C_{12}-C_{13}$, n is 0 and p is 1.3 and 1.8-2.2, respectively; and APG⁷ 600 with R^{15} being $C_{12}-C_{14}$, n is 0 and p is 1.3.

While esters of glucose are contemplated especially, it is envisaged that corresponding materials based on other reducing sugars, such as galactose and mannose are also suitable.

Particularly preferred nonionic surfactants are polyoxyethylene and polyoxypropylene condensates of linear aliphatic alcohols.

The preferred range of surfactant is from 0.5 to 30 % by wt., more preferably from 0.5 to 15% by wt of the composition.

Sequestrants

The compositions herein may also optionally contain one or more transition metal chelating agents. Such chelating agents can be selected from the group consisting of amino carboxylates, amino phosphonates, polyfunctionally-substituted aromatic chelating agents and mixtures therein. Without intending to be bound by theory, it is believed that the benefit of these materials is due in part to their exceptional ability to remove iron and manganese ions from washing solutions by formation of soluble chelates.

Amino carboxylates useful as optional chelating agents include ethylenediaminetetraacetates, N-hydroxyethylethylenediaminetriacetates, nitrilotriacetates, ethylenediamine tetrapropionates, triethylenetetraaminehexaacetates, diethylenetriaminepentaacetates, ethylenediamine disuccinate, and ethanoldiglycines, alkali metal, ammonium, and substituted ammonium salts therein and mixtures therein.

Amino phosphonates are also suitable for use as chelating agents in the compositions of the invention when at least low levels of total phosphorus are permitted in detergent compositions, and include ethylenediaminetetrakis (methylenephosphonates), nitrilotris (methylenephosphonates) and diethylenetriaminepentakis (methylenephosphonates). Preferably, these amino phosphonates do not contain alkyl or alkenyl groups with more than about 6 carbon atoms.

Polyfunctionally-substituted aromatic chelating agents are also useful in the compositions herein. See US-A-3,812,044. Preferred compounds of this type in acid form are

dihydroxydisulfobenzenes such as 1,2-dihydroxy-3,5-disulfobenzene.

If utilized, these chelating agents will generally comprise
5 from 0.1% to 10% by weight of the detergent compositions
herein. More preferably, if utilized, the chelating agents
will comprise from 0.1% to 5.0% by weight of such
composition.

10 Enzymes

Enzymes capable of facilitating the removal of soils from a
substrate may also be present in an amount of up to 10% by
wt., preferably 1 to 5 wt. %. Such enzymes include
15 proteases (e.g., Alcalase⁷, Savinase⁷ and Esperase⁷ from
Novo Industries A/S and Purafect Oxp⁷, ex. Genencor),
amylases (e.g., Termamyl⁷ and Duramyl⁷ from Novo Industries
and Purafect OxAm⁷, ex. Genencor).

20

Process Aids

Suitable binding and disintegrating agents for use in
tablets are described in the literature (see, for example,
25 "Pharmaceutical Dosage Forms : Volume 1", 1989, Marcel
Dekker Inc., ISBN 0-8246-804402). Both natural and
synthetic polymeric materials are suitable. These include
starch such as corn, rice and potato starch and starch
derivatives such as U-Sperse MTM and U-SperseTM provided by
30 National Starch PrimojelTM, carboxymethyl starch and sodium
glycolate such as ExplotabTM, pre-gelatinized corn starches
such as NationalTM 1551 and StarchTM 1500; cellulose and
cellulose derivatives including carboxymethyl cellulose such

as Courlose™ and Nymcel™, reticulated sodium carboxymethyl cellulose, such as Ac-Di-Sol™ provided by FMC Corporation, microcrystalline cellulose fibres such as Hanfloc™, microcrystalline cellulose such as Lattice™ NT provided by FMC Corporation and Avicel™ PH provided by FMC Corporation, methyl cellulose, ethyl cellulose, hydroxypropyl cellulose and hydroxypropylmethyl cellulose. Other useful polymers as binding/disintegrating agents are polyvinylpyrrolidone products such as Plasdone™, PVP™ K-30 and PVP™ K-60 all provided by International Specialty Products; polyvinylpyrrolidone products, a crosslinked product of N-vinyl-2-pyrrolidone such as Polyplasdone™ XL provided by International Specialty Products; polymethacrylates, polyvinyl alcohol and polyethylene glycols. Gums such as acacia, tragacanth, guar, locust bean gum and pectin, gelatin, sucrose and alginates are also suitable as binding/disintegrating agents. Suitable inorganic materials include magnesium-aluminium silicate such as Veegum™ HV provided by R.T. Vanderbilt Co.Inc., bentonite and montmorillonite such as Gelwhite™ provided by Southern Clay Products. Other suitable binding agents include monoglycerids such as Imwitor™ 191 provided by Huls America Inc., glyceril sterates such as Imwitor™ 900 provided by Huls America Inc., and palmoil glycerides such as Imwitor™ 940 provided by Huls America Inc.. The most preferred binding/disintegrating agents are microcrystalline cellulose and polyethylene glycols. The most preferred polyethylene glycols have a molecular weight of about 2000 to about 15000.

Other tablet additives commonly used are lubricant agents for aiding the tablet's processing, such as stearates, waxes, hydrogenated vegetable oils and polyethylene glycols

and charges such as sugars, sodium sulphate and sodium chloride.

Tablet Form

5

The tablet may be in the form of a layered product. The level of components may vary in each layer. In some instances it may be desirable to have no or low levels of bleaching ingredient with bleach sensitive ingredients such as perfume in one layer and the bleaching ingredient in a separate layer.

10

it is highly preferable if the tablets of the invention completely dissolve in 6 litres of water(4oFH) at 65°C within 14 minutes.

15

Particle Size

In the present invention, the total solid material within the tablet is preferably in the range from 0.005 to 1.0mm. in order to maximize the dissolution rate and increase the tablet's resistance.

20

Mixture and Addition Process

25

The addition order of the components of within the formulation can alter the appearance of the tablet.

30

It is preferable if water and any other liquid is added before the addition of any tripolyphosphate.

- 27 -

In the context of the present invention a tablet can be defined as any particulate material compacted to form a solid material, the tablet comprising at least one thousand particulates. Preferably the tablet has a diameter of

5 0.5 cm.

In a typical tablet formulation the addition of components are preferably as follows:

- 1st - filler
- 10 2nd - surfactant
- 3rd - silicone emulsion
- 4th - perfume
- 5th - buffering system
- 6th - bleaching system
- 15 7th - builder

Particularly preferred are formulations prepared by the addition of components in the following order:

- 20 1st - sodium carbonate
- 2nd - non-ionic surfactant
- 3rd - silicone emulsion
- 4th - perfume
- 5th - sodium disilicate
- 25 6th - tetraacetylene diamine (TAED)
- 7th - sodium perborate
- 8th - sodium tripolyphosphate
- 9th - enzymes

30 Tablet's Packaging

The packaging system of the present invention comprises a body (3) shaped to receive a tablet and a cover(4) which

- 28 -

keeps the tablet in the body. Preferably the cover covering the tablet is metallic.

It is particularly advantageous if the packaging system
5 avoids the physical contact of a user with the detergent tablet when placing the tablet in the dish washing machine.

Another important aspect of the present invention is the
combined use of the detergent material of the present
10 invention with a packaging of the type here illustrated in figure 1 and 2, as examples.

the invention will now be illustrated by means of the following non limiting Examples.

15

Example:

A detergent tablet according to the present invention
(Example 1) was prepared as follows.

20

In a mixer sodium carbonate was added. Under agitation non-ionic surfactant, silicone emulsion and perfume were added followed by the remaining powders in the sequence sodium disilicate, tetraacetylene diamine, sodium perborate, sodium
25 tripolyphosphate and finally enzymes. The resulting mixture was left under agitation until homogeneous then transferred to a press and compacted.

Example 1

	formulation	w/w(%)
5	Sodium tripolyphosphate	22.63
	Sodium disilicate	28.00
	Sodium carbonate	24.50
	Alcohol ethoxypropoxylate	1.00
10	Sodium perborate	6.00
	Tetracetylene diamine	2.00
	Enzyme protease	2.50
	Enzyme amylase	2.50
	Silicon emulsion	2.00
15	perfume/moisture/impurity	to 100

A dissolution test was performed in actual use conditions by placing a tablet in a plastic basket within a dish-washing machine Enxuta brand - Futura model, acquired in 1996. The selected cycle was set to a complete wash and the time taken for the tablet to completely dissolve was measured.

The obtained values are average values of 3 washes for each product.

The table given below demonstrates the tablet according to the invention dissolves completely within 14 minutes, while the comparative examples take longer than 14 minutes to completely dissolve.

Examples A to E are commercially available tablets.

CLAIMS

1. A machine dish washing tablet comprising a bleaching system, a silicone and less than 10 wt% of surfactant.
2. A machine dish washing tablet according to claim 1 or claim 2 in which the bleaching system comprises sodium perborate or sodium percarbonate.
3. A machine dish washing tablet according to any preceding claim wherein the silicone is selected from the group consisting of a polymers or copolymers of dimethyl silicone, aminomethoxy functionalised dimethyl silicone and mixtures thereof.
4. A machine dish washing tablet according to any preceding claim in which the particle size of the total solid material within the tablet is in the range from 0.005 to 1.0mm.
5. A machine dish washing composition according to any preceding claim in which the silicone is in the form of a silicone emulsion.
6. A machine dish washing tablet according to claim 5 in which the level of silicone emulsion added to the product is from 0.5 wt% to 10 wt% of the total product.
7. A machine dish washing tablet according to claims 5 or 6 in which the level of silicone within the silicone emulsion is from 2 wt% to 50 wt% of the total weight of the silicone emulsion.

8. A machine dish washing tablet according to any one of claims 5 , 6 or 7 in which the silicone is emulsified with a nonionic surfactant.
9. A process for preparing machine dish washing tablets comprising the step of adding a silicone emulsion to a formulation that is to be tabletted.
10. A dish washing tablet(1) and a packaging system (2) the packaging system comprising a body (3) shaped to receive a tablet and a cover(4) which keeps the tablet in the body.
11. A dish washing tablet and a packaging system according to claim 1 in which the cover(3) is metallic.
12. A dish washing tablet packaging system according to claim 10 or claim 11 in that the packaging system avoids the physical contact of a user with the detergent tablet when using the tablet.
13. Detergent composition package as illustrated by figures 1 and 2.
14. Use of a packaging system comprising a body (3) shaped to receive a tablet and a cover(4) which keeps the tablet in the body, to store a machine dish washing tablet.

15. A machine dish washing tablet as claimed in claim 1 and substantially as described herein.

1/1

Fig.1.

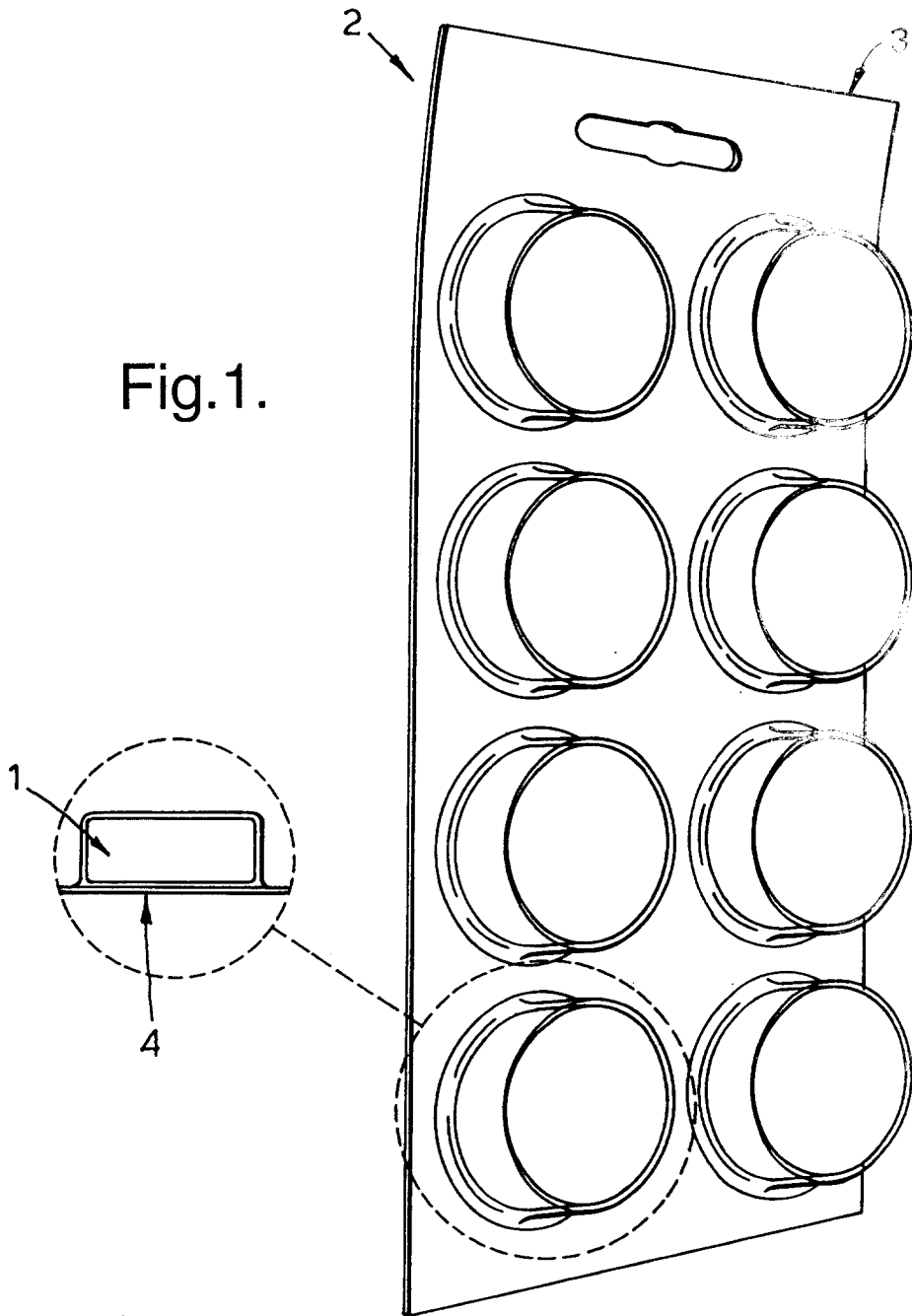

Fig.2.

