



US007528455B2

(12) **United States Patent**
Ahn

(10) **Patent No.:** **US 7,528,455 B2**
(45) **Date of Patent:** **May 5, 2009**

(54) **NARROW WIDTH METAL OXIDE SEMICONDUCTOR TRANSISTOR**

(75) Inventor: **Jung Ho Ahn**, Chungbuk (KR)

(73) Assignee: **Dongbu Electronics Co., Ltd.**, Seoul (KR)

(*) Notice: Subject to any disclaimer, the term of this patent is extended or adjusted under 35 U.S.C. 154(b) by 49 days.

(21) Appl. No.: **11/646,727**

(22) Filed: **Dec. 27, 2006**

(65) **Prior Publication Data**

US 2007/0152244 A1 Jul. 5, 2007

(30) **Foreign Application Priority Data**

Dec. 29, 2005 (KR) 10-2005-0134163

(51) **Int. Cl.**

- H01L 29/76** (2006.01)
- H01L 29/94** (2006.01)
- H01L 31/062** (2006.01)
- H01L 31/113** (2006.01)
- H01L 31/119** (2006.01)
- H01L 27/10** (2006.01)
- H01L 29/739** (2006.01)
- H01L 29/73** (2006.01)

(52) **U.S. Cl.** **257/401**; 257/202; 257/204; 257/206; 257/210; 257/E29.134; 257/E29.135; 257/E29.136

(58) **Field of Classification Search** 257/202, 257/204, 206, 401, 201, E29.134, E29.135, 257/E29.136

See application file for complete search history.

(56) **References Cited**

U.S. PATENT DOCUMENTS

5,821,600	A *	10/1998	Chan	257/508
6,476,424	B1 *	11/2002	Ishida	257/206
6,692,996	B2 *	2/2004	Lee et al.	438/149
6,787,823	B2 *	9/2004	Shibutani	257/206
6,933,578	B2 *	8/2005	Sato	257/393
7,064,453	B2 *	6/2006	Sato	257/202
7,093,215	B2 *	8/2006	Sahara et al.	716/4
7,105,901	B1 *	9/2006	Miyanishi et al.	257/401
2002/0093028	A1 *	7/2002	Konishi et al.	257/100
2003/0042529	A1 *	3/2003	Hashimoto et al.	257/315
2004/0238897	A1 *	12/2004	Oishi	257/369
2005/0093019	A1 *	5/2005	Kato	257/192
2006/0006474	A1 *	1/2006	Tsui	257/369

* cited by examiner

Primary Examiner—Ida M Soward

(74) *Attorney, Agent, or Firm*—Andrew D. Fortney

(57) **ABSTRACT**

Disclosed is a semiconductor transistor for enhancing performance of PMOS and NMOS transistors, particularly current driving performance, while reducing a narrow width effect. A narrow width MOS transistor includes: a channel of which width is W_0 and length is L_0 ; an active area including source and drain areas formed at both sides with the channel as a center; a gate insulating layer formed on the channel; a gate conductor formed on the gate insulating layer and intersecting the active area; a first additional active area of width is larger than that W_0 of the channel as an active area added to the source area; and a second additional active area of width is larger than that W_0 of the channel as an active area added to the drain area. When the structure of the transistor having the additional active areas is applied to NMOS and PMOS transistors, a driving current is represented as 107.27% and 103.31%, respectively. Accordingly, the driving currents of both PMOS and NMOS transistors are enhanced.

20 Claims, 3 Drawing Sheets

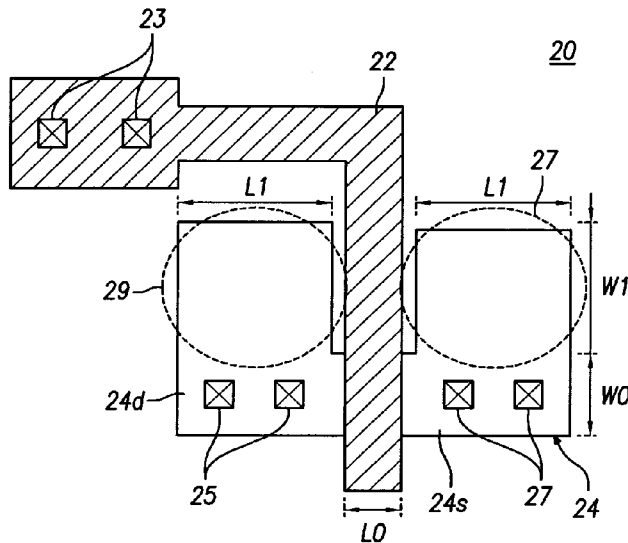

Fig. 1

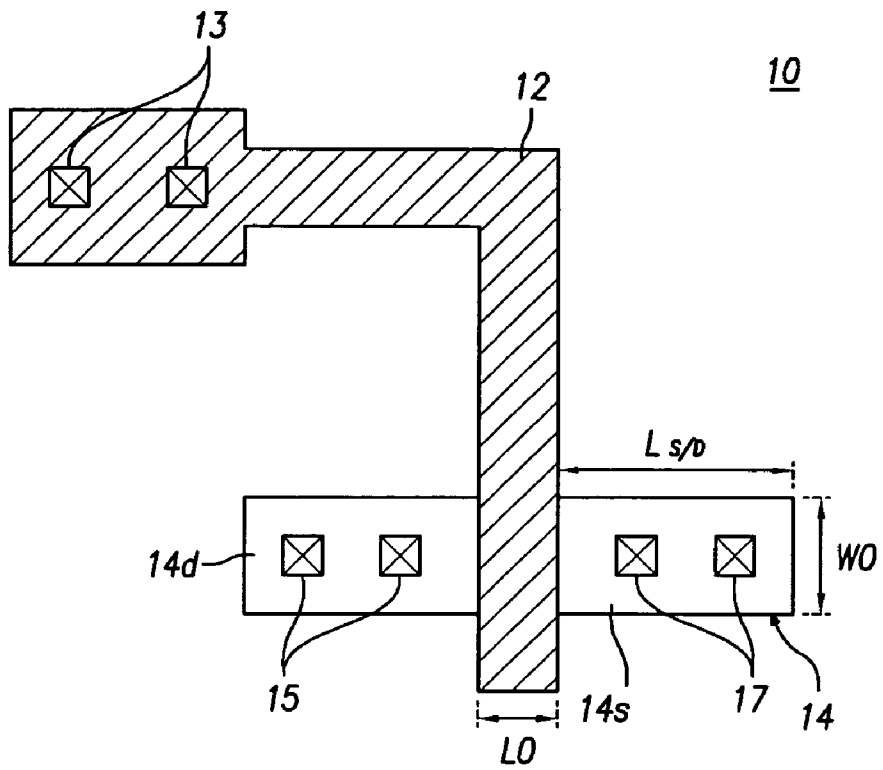

Fig. 2

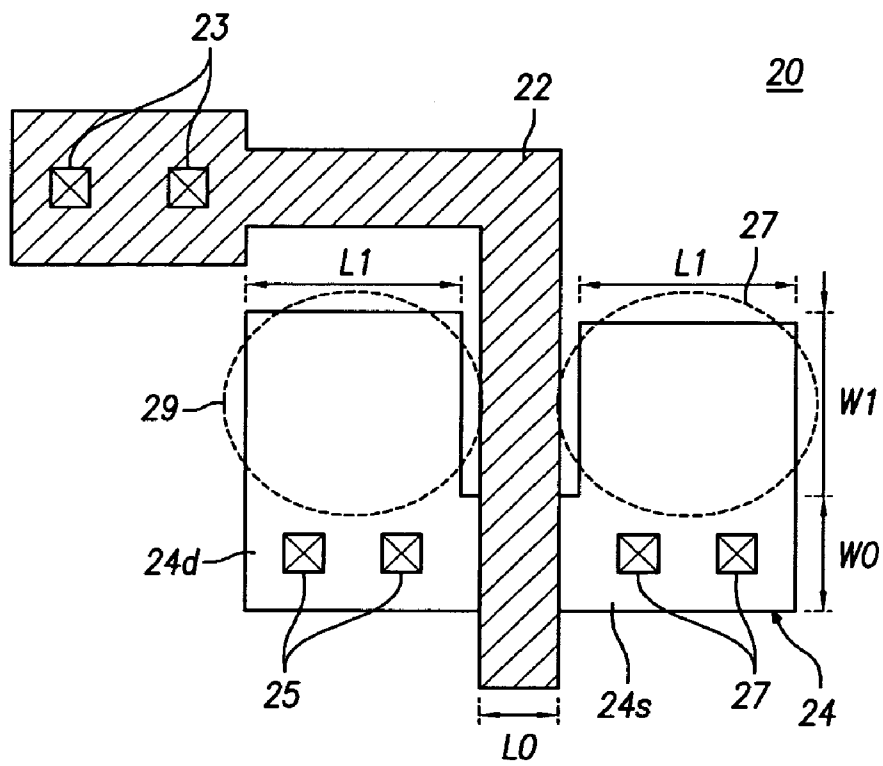

Fig. 3

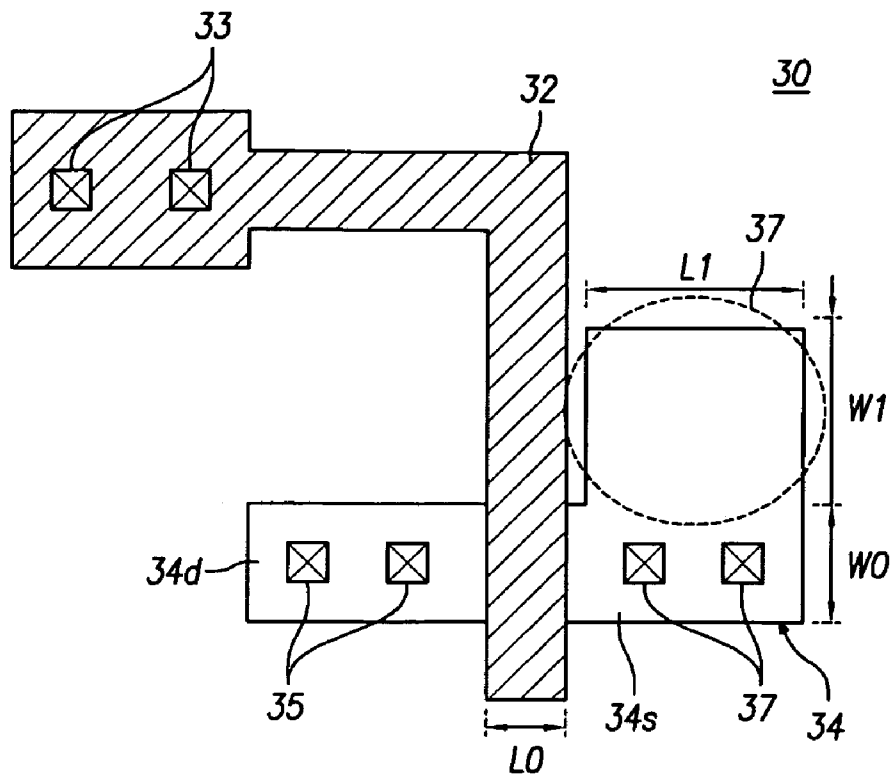

Fig. 4

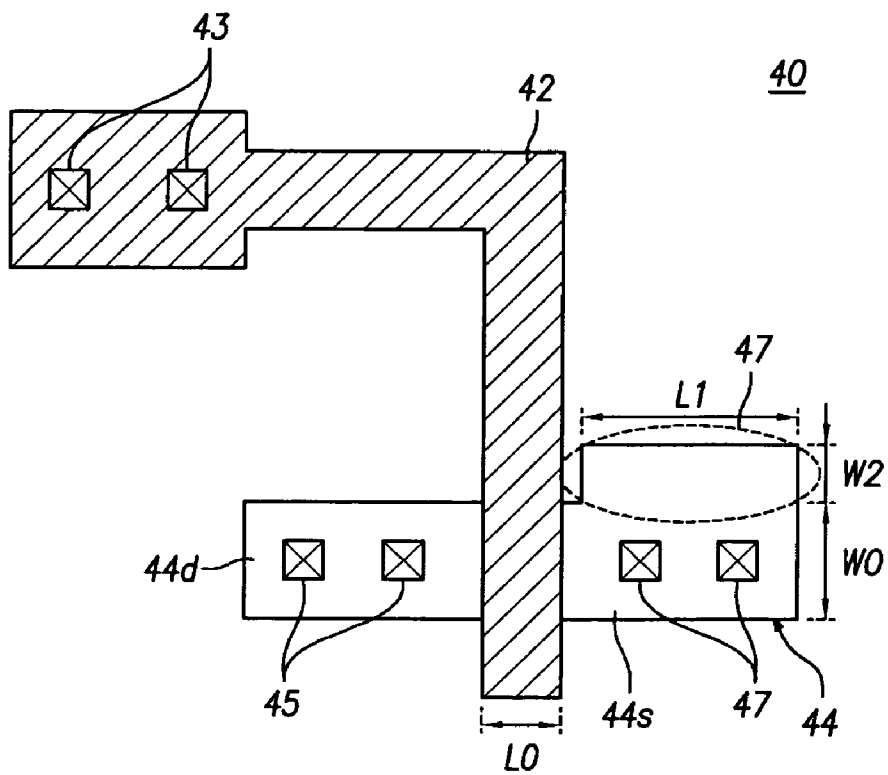
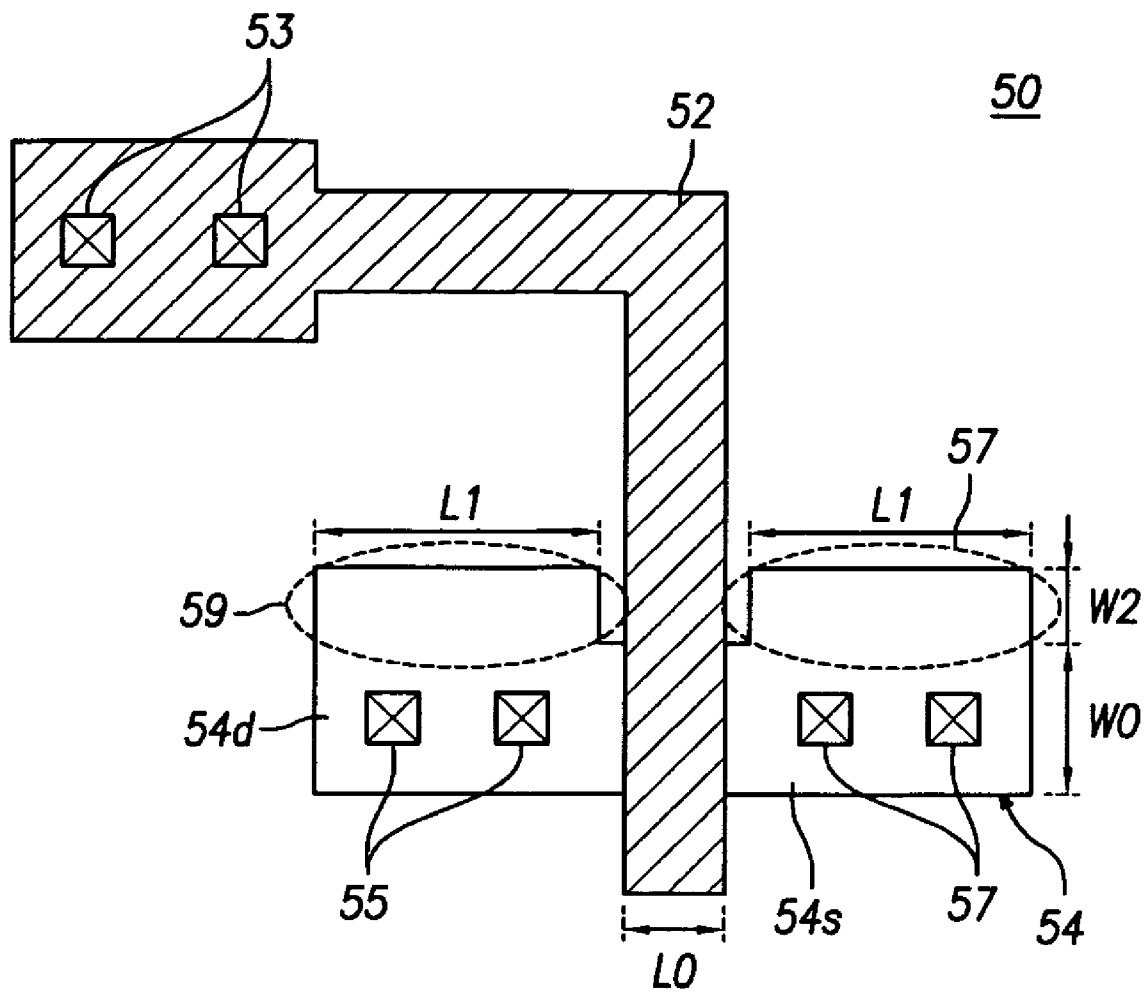

Fig. 5



NARROW WIDTH METAL OXIDE SEMICONDUCTOR TRANSISTOR

BACKGROUND OF THE INVENTION

1. Field of the Invention

The present invention relates to a semiconductor transistor, and more particularly to a semiconductor transistor for enhancing the performance of PMOS and NMOS transistors, particularly the driving current performance, while reducing the narrow width effect.

2. Description of the Related Art

As the size of transistors is scaled down, the narrow width and reverse narrow width effects have emerged as serious problems, together with the short channel effect. Since a portion of a gate electrode generally overlaps with an isolation area, the narrow width effect is influenced by parasitic charges due to the bird's beak of an isolation layer or field stop impurities. Therefore, more charges are supplied than when a gate forms a channel of a transistor, and thus there is an advantage in that the threshold voltage of the transistor increases as a channel width becomes narrow.

In general, as the channel width of a transistor becomes narrow, a threshold voltage increases due to the narrow width effect. However, a threshold voltage may decrease depending on the manufacturing process. For example, if a field oxide layer is formed and an ion implantation is then performed with respect to the field oxide layer, impurities in a field area are distributed to have a lower density than in a channel area of a transistor. For this reason, there appears a phenomenon in which a threshold voltage increases as a channel width becomes narrow.

Further, if an isolation area is formed with LOCOS (Local Oxidation of Silicon) in a process of manufacturing a transistor with a narrow channel width, a threshold voltage generally increases. However, if an isolation area is formed through an STI (Shallow Trench Isolation), the threshold voltage decreases, and thus a current increases.

Meanwhile, if the channel lengths and widths of PMOS and NMOS transistors are adjusted to enhance their performance, the performance of one transistor is enhanced but the performance of the other transistor is deteriorated. Thus, it is important to simultaneously enhance the performance of PMOS and NMOS transistors when enhancing the performance of transistors, such as current driving performance.

SUMMARY OF THE INVENTION

An object of the present invention is to provide a semiconductor transistor for enhancing the performance of PMOS and NMOS transistors while reducing the narrow width effect.

Another object of the present invention is to provide a semiconductor transistor for enhancing the current driving performance of a MOS transistor with a narrow channel width.

According to one aspect of the present invention, there is provided a MOS transistor made of a metal oxide semiconductor, which includes: a channel of which width is W_0 and length is L_0 ; an active area including source and drain areas formed at both sides with the channel as a center; a gate insulating layer formed on the channel; a gate conductor formed on the gate insulating layer and intersecting the active area; a first additional active area of width is larger than that W_0 of the channel as an active area added to the source area;

and a second additional active area of width is larger than that W_0 of the channel as an active area added to the drain area.

BRIEF DESCRIPTION OF THE DRAWINGS

FIG. 1 is a plan layout view showing a reference transistor for illustrating a structural characteristic of a transistor according to the present invention;

FIG. 2 is a plan layout view illustrating a structure of the transistor according to the present invention;

FIG. 3 is a plan layout view showing a first comparison transistor compared with the structure of the transistor according to the present invention;

FIG. 4 is a plan layout view showing a second comparison transistor compared with the structure of the transistor according to the present invention; and

FIG. 5 is a plan layout view showing a third comparison transistor compared with the structure of the transistor according to the present invention.

DETAILED DESCRIPTION OF THE INVENTION

Hereinafter, preferred embodiments of the present invention will be described with reference to the accompanying drawings.

FIG. 1 is a plan layout view showing a reference transistor for illustrating a structural characteristic of a transistor according to the present invention.

The transistor shown in FIG. 1 includes a gate conductor **12** and an active area **14**. The gate conductor **12**, for example, is made of poly-silicon and intersects the active area **14**. The active area **14** is an area in which impurities (e.g., N-type impurities such as P, As and N, or P-type impurities such as B, Ga and In) are implanted or diffused onto a semiconductor (e.g., silicon) substrate. The active area **14** is divided into source and drain areas **14s** and **14d** with the gate conductor **12** overlapping with the active area **14** as reference.

Since a gate insulating layer (not shown) is formed beneath a surface of the gate conductor **12** overlapping with the active area **14**, the gate conductor **12** is electrically isolated from the active area **14**. The gate conductor **12** is connected electrically to the outside (e.g., a gate electrode) through gate contact holes **13**. Further, the source and drain areas **14s** and **14d** are connected electrically to the outside through source and drain contact holes **17** and **15**, respectively.

If a bias voltage (a positive (+) voltage in an NMOS transistor or a negative (-) voltage in a PMOS transistor) of a threshold voltage or more is applied to the gate conductor **12**, an electric field is formed with the gate conductor as a center, and a channel (not shown) is formed below the gate insulating layer due to the influence of the electric field. If the channel is formed by a gate voltage, a current flows between the source and drain areas **14s** and **14d**. Since the current does not flow through the channel if the bias voltage is removed, the operation of a transistor can be implemented. Since the transistor includes a semiconductor substrate, a gate insulating layer and a gate conductor, the transistor is referred to as a MOS transistor.

The MOS transistor **10** of FIG. 1 is a narrow width transistor having a small width W_0 of 0.3 μm and a channel length L_0 of 0.13 μm . When the MOS transistor **10** having such dimension and structure is implemented as NMOS and PMOS transistors, assuming that each driving current of the NMOS and PMOS transistors is 100, the inventor of the present invention has studied a structure of a transistor capable of optimizing the driving current while varying the structure and dimension of the transistor. As a result, it can be seen that a driving current is the most optimally enhanced in the structure and dimension of a transistor shown in FIG. 2, and both performance enhancements for PMOS and NMOS transistors can be achieved.

That is, the transistor **20** according to the present invention includes source and drain additional active areas **27** and **29** respectively having the source and drain areas extended in a channel width direction as shown in FIG. 2. The length **L1** of each of the additional active areas **27** and **29** is set to be smaller than that $L_{s/d}$ of each of the source and drain areas **14s** and **14d** of the reference transistor **10** (FIG. 1) such that the channel width itself of the transistor **20** does not increase due to the additional active areas **27** and **29**. Here, a difference between **L1** and $L_{s/d}$ is set to be maximal as long as the design rule accepts it.

Since the respective additional active areas **27** and **29** are the same areas in which impurities are diffused as the source and drain areas **24s** and **24d**, only the pattern of a mask is modified to include a pattern corresponding to the additional active areas **27** and **29** without utilizing an additional photo mask to form the additional active areas **27** and **29**. That is, in order to form the additional active areas **27** and **29** of the present invention, it is not required to modify a semiconductor manufacturing method or to introduce a new process.

According to an embodiment of the present invention, the width **W1** of each of the additional active areas **27** and **29** is $0.35\ \mu\text{m}$, and the length **L1** thereof is $0.3\ \mu\text{m}$. That is, the width of each of the additional active areas **27** and **29** according to the present invention is larger than the channel width of the transistor **20**. The channel width **W0** and length **L0** of the transistor **20** are the same as those of the reference transistor **10**. When the structure of a transistor is modified to include the additional active areas **27** and **29** having such dimensions and the structure is applied to an NMOS transistor, the driving current of the transistor **20** is represented as 107.27% as compared with that of the reference transistor **10**. When the structure is applied to a PMOS transistor, the driving current is represented as 103.31%. That is, it can be seen that the current driving performance of the transistor **20** of the present invention is represented as 103% or more in both PMOS and NMOS transistors as compared with that of the reference transistor **10** so that both performance of the PMOS and NMOS transistors can be simultaneously enhanced.

As shown in FIG. 2, the transistor **20** according to the present invention is a MOS transistor in which an active area **24** having the source and drain areas **24s** and **24d** intersects a gate conductor **22**, the gate conductor **22** is connected electrically to the outside through gate contact holes **23**, and the source and drain areas **24s** and **24d** are connected electrically to the outside through source and drain contact holes **27** and **25**, respectively.

FIG. 3 is a plan layout view showing a first comparison transistor compared with the structure of the transistor according to the present invention.

As shown in FIG. 3, the first comparison transistor **30** is a MOS transistor in which an active area **34** having source and drain areas **34s** and **34d** intersects a gate conductor **32**, the gate conductor **32** is connected electrically to the outside through gate contact holes **33**, and the source and drain areas **34s** and **34d** are connected electrically to the outside through source and drain contact holes **37** and **35**, respectively.

In the first comparison transistor **30**, an additional active area is formed at any one of source and drain areas. As an example, an additional active area **37** is added to the source area **34s** in this figure. The width **W1** and length **L1** of the additional active area **37** is identical to the additional active areas **27** and **29** of the transistor **20** according to the present invention. As such, the width **W1** of the additional active area **37** is set to be $0.35\ \mu\text{m}$, and the channel width and length of the first comparison transistor **30** is set to be identical to the reference transistor **10**. When the structure having such dimensions is applied to an NMOS transistor, the driving current of the first comparison transistor **30** is represented as 101.14% as compared with the reference transistor **10**. When the structure is applied to a PMOS transistor, the driving

current is represented as 100.00%, representing no difference between the first comparison transistor **30** and the reference transistor **10**.

FIG. 4 is a plan layout view showing a second comparison transistor compared with the structure of the transistor according to the present invention.

As shown in FIG. 4, the second comparison transistor **40** is a MOS transistor in which an active area **44** having source and drain areas **44s** and **44d** intersects a gate conductor **42**, the gate conductor **42** is connected electrically to the outside through gate contact holes **43**, and the source and drain areas **44s** and **44d** are connected electrically to the outside through source and drain contact holes **47** and **45**, respectively.

In the second comparison transistor **40**, an additional active area is formed at any one of source and drain areas like the first comparison transistor **30**. As an example, an additional active area **47** is added to the source area **44s** in this figure. The width **W2** of the additional active area **47** is smaller than those of the additional active areas **27** and **29** of the transistor **20** according to the present invention. The length **L1** of the additional active area **47** is identical to the transistor **20** of the present invention. As such, the width **W2** of the additional active area **47** is set to be $0.3\ \mu\text{m}$, which is smaller than **W1**, and the channel width and length of the second comparison transistor **40** is set to be identical to the reference transistor **10**. When the structure having such dimensions is applied to an NMOS transistor, the driving current of the second comparison transistor **40** is represented as 101.82% as compared with the reference transistor **10**. When the structure is applied to a PMOS transistor, the driving current is represented as 98.90%, which is smaller than that of the reference transistor **10**.

FIG. 5 is a plan layout view showing a third comparison transistor compared with the structure of the transistor according to the present invention.

As shown in FIG. 5, the third comparison transistor **50** is a MOS transistor, like the reference transistor **10**, in which an active area **54** having source and drain areas **54s** and **54d** intersects a gate conductor **52**, the gate conductor **52** is connected electrically to the outside through gate contact holes **53**, and the source and drain areas **54s** and **54d** are connected electrically to the outside through source and drain contact holes **57** and **55**, respectively.

In the third comparison transistor **50**, additional active areas **57** and **59** are respectively formed at both source and drain areas **54s** and **54d** like the transistor **20** of the present invention. At this time, the width **W2** of each of the additional active areas **57** and **59** is smaller than that **W1** of each of the additional active areas **27** and **29** of the transistor **20** according to the present invention. The length **L1** of each of the additional active areas **57** and **59** is identical to the transistor **20** of the present invention. As such, the width **W2** of each of the additional active areas **57** and **59** is set to be $0.3\ \mu\text{m}$, which is smaller than **W1**, and the channel width and length of the third comparison transistor **50** are set to be identical to the reference transistor **10**. When the structure having such dimensions is applied to an NMOS transistor, the driving current of the third comparison transistor **50** is represented as 100.68% as compared with the reference transistor **10**. When the structure is applied to a PMOS transistor, the driving current is represented as 100.55%, representing little difference between the third comparison transistor **50** and the reference transistor **10**.

Comparing the channel widths and lengths of the reference transistor **10**, transistor **20** of the present invention, and first to third comparison transistors **30**, **40** and **50**, the widths and lengths of the additional active areas **27**, **29**, **37**, **47**, **57** and **59**, and the driving currents when the respective transistors are implemented as an NMOS or PMOS transistor, with the dimensions of the aforementioned embodiments as reference, they are shown in the following Table:

TABLE 1

Classification	Channel Width	Channel length	Additional Active Area	Width of Additional Active Area	Length of Additional Active Area	NMOS Driving Current	PMOS Driving Current
Ref Trans.	0.3 μm	0.13 μm	None	—	—	100	100
Trans. of present invention	0.3 μm	0.13 μm	2	0.35 μm	0.3 μm	107.27%	103.31%
1 st Comparison Trans.	0.3 μm	0.13 μm	1	0.35 μm	0.3 μm	101.14%	100.0%
2 nd comparison Trans.	0.3 μm	0.13 μm	1	0.3 μm	0.3 μm	101.82%	98.90%
3 rd comparison trans.	0.3 μm	0.13 μm	2	0.3 μm	0.3 μm	100.68%	100.55%

15

As shown in Table 1, the structure of the transistor **20** according to the present invention is not modified by setting the channel width and length of the transistor **20** to be identical to the reference transistor **10**, and the additional active areas **27** and **29** is added to the transistor **20**, so that the driving currents of both NMOS and PMOS transistors can be enhanced by 103% or more.

According to the present invention, problems with both PMOS and NMOS transistors can be solved because a driving control drops due to a narrow width effect while the channel width of a transistor is reduced.

Further, in order to improve the driving current performance of the transistor according to the present invention, it is not necessary to add an additional process or to modify a process itself, so that the performance of a MOS transistor can be enhanced without additional costs.

While the invention has been shown and described with reference to certain preferred embodiments thereof, it will be understood by those skilled in the art that various changes in form and details may be made therein without departing from the spirit and scope of the invention as defined by the appended claims.

What is claimed is:

1. A MOS transistor comprising:
 - a channel having a width W_0 and a length L_0 ;
 - an active area including source and drain areas at opposite sides of the channel;
 - a gate insulating layer on the channel;
 - a gate conductor on the gate insulating layer and intersecting the active area having a contact region that does not intersect the active area, wherein the contact region has a length and width that are both greater than a length of the gate conductor;
 - a first additional active area having a width larger than W_0 added to the source area; and
 - a second additional active area having a width larger than W_0 added to the drain area.
2. The MOS transistor of claim 1, wherein the active area comprises N-type impurities.
3. The MOS transistor of claim 1, wherein the active area comprises P-type impurities.
4. The MOS transistor of claim 1, wherein the first and second additional active areas are continuous with the source and drain areas.
5. The MOS transistor of claim 1, wherein the transistor is a narrow width transistor.
6. The MOS transistor of claim 1, further comprising one or more contacts on the contact region of the gate conductor.
7. The MOS transistor of claim 1, wherein the gate conductor comprises a first portion intersecting the active area and a second portion perpendicular to the first portion and not

intersecting the active area, the second portion connected at a first end to the first portion and at opposite end to the contact region.

8. The MOS transistor of claim 1, wherein the first and second additional active areas each have lengths larger than lengths of the source and drain areas.

9. The MOS transistor of claim 1, wherein the gate conductor has a first end intersecting the channel and an opposite end connected to the contact region of the gate conductor.

10. The MOS transistor of claim 9, wherein the first and second additional active areas adjacent to a second portion of the gate conductor that does not intersect the channel.

11. The MOS transistor of claim 10, wherein the source and drain areas each include a contact region therein.

12. The MOS transistor of claim 10, wherein the second portion of the gate conductor is adjacent to the first and second additional active areas, and the gate conductor does not intersect the first and second additional active areas.

13. The MOS transistor of claim 11, further comprising one or more contacts on each of the contact regions of the source and drain areas.

14. A MOS transistor, comprising:

- a channel having a width W_0 and a length L_0 ;
- an active area including source and drain areas at opposite sides of the channel;
- a gate insulating layer on the channel;
- a gate conductor on the gate insulating layer and intersecting the active area having a contact region that does not intersect the active area, wherein the contact region has a length and width that are both greater than a length of the gate conductor; and
- a first additional active area having a width larger than W_0 added to the source or drain area.

15. The MOS transistor of claim 14, wherein the active area comprises N-type impurities or P-type impurities.

16. The MOS transistor of claim 14, wherein the first additional active area is continuous with the source area.

17. The MOS transistor of claim 14, further comprising one or more contacts on the contact region of the gate conductor.

18. The MOS transistor of claim 14, wherein the gate conductor has a first end intersecting the channel and an opposite end connected to the contact region of the gate conductor.

19. The MOS transistor of claim 18, wherein the first additional active area is adjacent to a second portion of the gate conductor that does not intersect the channel.

20. The MOS transistor of claim 19, wherein the second portion of the gate conductor is adjacent to the first additional active area, and the gate conductor does not intersect the first additional active area.

* * * * *