

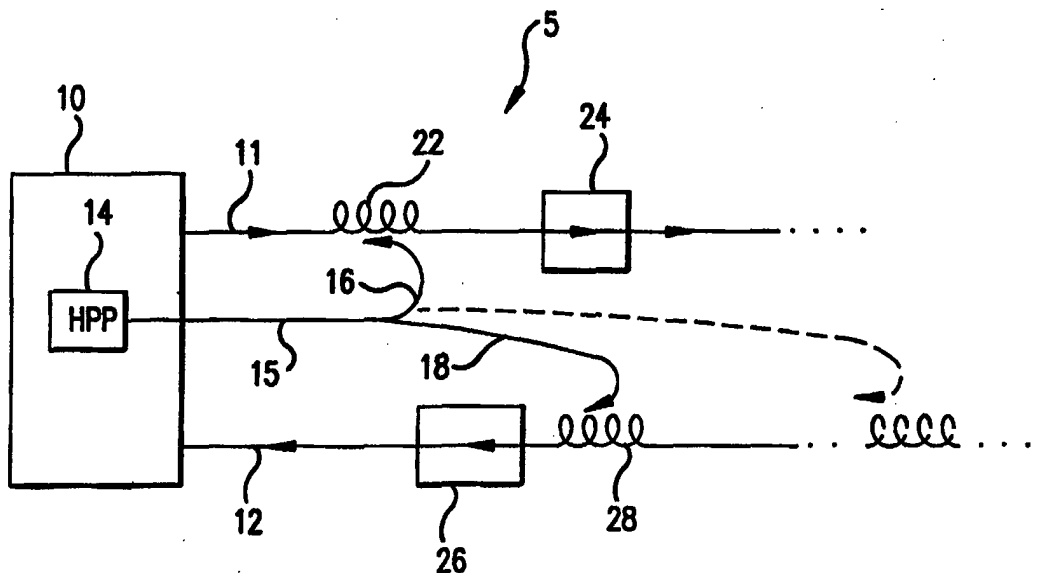

INTERNATIONAL APPLICATION PUBLISHED UNDER THE PATENT COOPERATION TREATY (PCT)

<p>(51) International Patent Classification ⁶ : H01S 3/30</p>	<p>A1</p>	<p>(11) International Publication Number: WO 98/20587 (43) International Publication Date: 14 May 1998 (14.05.98)</p>
<p>(21) International Application Number: PCT/US97/18436 (22) International Filing Date: 15 October 1997 (15.10.97) (30) Priority Data: 08/742,527 1 November 1996 (01.11.96) US (71) Applicant: TYCO SUBMARINE SYSTEMS LTD. [US/US]; 101 Crawfords Corner Road, Holmdel, NJ 07733 (US). (72) Inventors: KERFOOT, Franklin, W. III; 52 Jean Terrace, Red Bank, NJ 07701 (US). KIDORF, Howard, D.; 82 Tower Hill Drive, Red Bank, NJ 07701 (US). MA, Xi- aobing; 72 Wedgewood Circle, Eatontown, NJ 07724 (US). ROTTWITT, Karsten; 908 Wellington Place, Aberdeen, NJ 07747 (US). (74) Agents: PIETRANTONIO, Frank; Kenyon & Kenyon, 1025 Connecticut Avenue, N.W., Washington, DC 20036-5405 (US) et al.</p>		<p>(81) Designated States: AU, CA, JP, KR, MX, NZ, European patent (AT, BE, CH, DE, DK, ES, FI, FR, GB, GR, IE, IT, LU, MC, NL, PT, SE). Published <i>With international search report.</i> <i>With amended claims.</i></p>

(54) Title: A MULTI-WAVELENGTH OPTICAL PUMP



(57) Abstract

A high-powered optical pump (15) includes at least two sub-pumps (36, 37). Each sub-pump (36, 37) generates a light at different wavelengths. The outputs of the sub-pumps (36, 37) are coupled to a remote pump fiber (15). The resulting light transmitted on the remote pump fiber (15) results in a lower raman gain and raman noise spectral peak than that generated by existing single wavelength high-powered optical pumps at the same power level. Therefore, increased power can be transmitted on the remote pump fiber (15) in contrast to a single wavelength pump.

FOR THE PURPOSES OF INFORMATION ONLY

Codes used to identify States party to the PCT on the front pages of pamphlets publishing international applications under the PCT.

AL	Albania	ES	Spain	LS	Lesotho	SI	Slovenia
AM	Armenia	FI	Finland	LT	Lithuania	SK	Slovakia
AT	Austria	FR	France	LU	Luxembourg	SN	Senegal
AU	Australia	GA	Gabon	LV	Latvia	SZ	Swaziland
AZ	Azerbaijan	GB	United Kingdom	MC	Monaco	TD	Chad
BA	Bosnia and Herzegovina	GE	Georgia	MD	Republic of Moldova	TG	Togo
BB	Barbados	GH	Ghana	MG	Madagascar	TJ	Tajikistan
BE	Belgium	GN	Guinea	MK	The former Yugoslav Republic of Macedonia	TM	Turkmenistan
BF	Burkina Faso	GR	Greece	ML	Mali	TR	Turkey
BG	Bulgaria	HU	Hungary	MN	Mongolia	TT	Trinidad and Tobago
BJ	Benin	IE	Ireland	MR	Mauritania	UA	Ukraine
BR	Brazil	IL	Israel	MW	Malawi	UG	Uganda
BY	Belarus	IS	Iceland	MX	Mexico	US	United States of America
CA	Canada	IT	Italy	NE	Niger	UZ	Uzbekistan
CF	Central African Republic	JP	Japan	NL	Netherlands	VN	Viet Nam
CG	Congo	KE	Kenya	NO	Norway	YU	Yugoslavia
CH	Switzerland	KG	Kyrgyzstan	NZ	New Zealand	ZW	Zimbabwe
CI	Côte d'Ivoire	KP	Democratic People's Republic of Korea	PL	Poland		
CM	Cameroon	KR	Republic of Korea	PT	Portugal		
CN	China	KZ	Kazakstan	RO	Romania		
CU	Cuba	LC	Saint Lucia	RU	Russian Federation		
CZ	Czech Republic	LI	Liechtenstein	SD	Sudan		
DE	Germany	LK	Sri Lanka	SE	Sweden		
DK	Denmark	LR	Liberia	SG	Singapore		
EE	Estonia						

A MULTI-WAVELENGTH OPTICAL PUMP

BACKGROUND OF THE INVENTION

The present invention is directed to an optical pump
5 used with a remote amplifier. More particularly, the
present invention is directed to an optical pump that
produces light at a plurality of wavelengths.

Optical transmission systems have recently been
developed that utilize remote amplifiers to amplify
10 optical signals. Fig. 1 illustrates a section of an
exemplary optical transmission system that includes remote
amplifiers.

The optical transmission system 5 includes a pair of
optical fibers 11, 12 on which optical signals travel in
15 the direction indicated by the arrows. Multiple repeaters
are placed along the fibers 11, 12. One such repeater 10
is shown in Fig. 1. The repeater 10 includes a high-
powered optical pump 14. Coupled to the high-powered
optical pump 14 is a remote pump fiber 15 that extends
20 externally from the repeater 10. The remote pump fiber 15
includes branches 16, 18.

The transmission system 5 further includes multiple
remote erbium doped fibers (EDFs) 22, 28 disposed along
the fibers 11, 12. Each remote EDF 22, 28 is coupled to
25 a section of the remote pump fiber 15 and to an optical
isolator through a wavelength division multiplexer (not
shown). For example, erbium doped fiber 22 is disposed on
fiber 11 and is coupled to remote pump fiber branch 16 and

optical isolator 24. Erbium doped fiber 28 is disposed on fiber 12 and is coupled to remote pump fiber branch 18 and optical isolator 26. The arrangement of remote pump fibers and erbium doped fibers amplifies the optical signals on the fibers 11, 12 in a known way.

In the optical transmission system 5, it is desirable for the optical signal supplied by the pump 14 to the remote pump fiber 15 to have as large amount of power as possible for multiple reasons. First, as the power is increased at the input of the fiber 15, power at the output of the fiber 15 (at remote pump fiber branches 16, 18) where it is coupled to the erbium doped fibers 22, 28 is increased, thus increasing the amount of amplification provided by the erbium doped fibers 22, 28.

Further, as the power is increased, the length of the remote pump fiber 15 can be increased and therefore the distance between the pump 14 and the fibers 22, 28 can be increased.

Finally, as the power is increased, more branches similar to remote pump fiber branches 16, 18 can be coupled to the remote pump fiber 15 and used to pump additional remote erbium doped fibers.

However, optical fibers are limited in how much power they can carry. This limitation is caused by the effects of Raman gain and Raman noise.

In Fig. 2, the curve 32 is typical of the spectral dependence of the Raman gain coefficient for a silica optical fiber pumped at 1480 nm (see Govind P. Agrawal, Nonlinear Fiber Optics, Second Edition, Academic Press, 1995, pg. 318). The resultant gain spectrum in a lossless fiber is related exponentially to the gain coefficient by:

$$G(\lambda) = e^{[g_r(\lambda)P \frac{L}{A}]}$$

where P is the optical pump power and L/A is the effective length divided by the effective cross-sectional area of the fiber and is the property of the particular optical fiber. The curve 32 is centered around 1583 nm and has a spectral peak of approximately C_4 .

The resultant Raman noise spectrum is similar to the Raman gain spectrum and is centered around 1583 nm, the Stokes-shifted wavelength. However, light at this wavelength is of no use in providing pump power to the remote erbium doped fibers 22, 28 because it is at the wrong wavelength. Therefore, the generated Raman noise is an undesirable byproduct of the remote pump 14 because it reduces the power of the useful light that is supplied to the remote erbium doped fibers 22, 28. Further, the amplitude of both the Raman noise and the Raman gain in the fiber 15 increases exponentially as the amplitude of the input pump 14 is increased.

In addition to being subject to Raman gain, the Raman noise is also reflected inside the fiber 15 through the process of Rayleigh reflection. These reflections cause the generated noise to be subject to more gain than it would otherwise. When the fiber's gain reaches a threshold, the fiber 15 will lase at the peak Stokes-shifted wavelength. This is a limiting condition where an overwhelming amount of pump power is converted to the Stokes-shifted wavelength. *Further,*

Based on the foregoing, there is a need for an improved high-powered pump that enables additional power to be input into the remote pump fiber 15.

30

SUMMARY OF THE INVENTION

The present invention is a high-powered optical pump that includes at least two sub-pumps. Each sub-pump generates light at different wavelengths. The outputs of

the sub-pumps are coupled to a remote pump fiber. The resulting light transmitted on the remote pump fiber results in a lower Raman gain and Raman noise spectral peak than that generated by existing single wavelength high-powered optical pumps at the same power level. Therefore, increased power can be transmitted on the remote pump fiber using the present invention in contrast to a single wavelength pump.

10 BRIEF DESCRIPTION OF THE DRAWINGS

Fig. 1 illustrates a section of an exemplary optical transmission system that includes remote repeaters.

Fig. 2 is a graph of the gain coefficient versus wavelength of a remote pump fiber.

15 Fig. 3 is a block diagram of the present invention.

Fig. 4 is a graph of the gain coefficient versus wavelength of a fiber pumped with an optical pump generating two different wavelengths in accordance with the present invention.

20

DETAILED DESCRIPTION

Fig. 3 is a block diagram of the present invention which is an improved high-powered optical pump 35 intended to replace the high-powered pump 14 in the optical transmission system 5 shown in Fig. 1. The high-powered pump 35 includes two sub-pumps 36, 37, each generating light at a different wavelength. In one embodiment, sub-pump 36 generates light at 1450 nm and sub-pump 37 generates light at 1500 nm. These wavelengths are chosen for this embodiment because they are separated sufficiently to significantly reduce the peak gain coefficient but are still effective at remotely pumping an erbium doped fiber to achieve optical gain.

In one embodiment, the total output power of the pump 35 is equal to the total output power of the pump 14 in order to provide a comparison of the corresponding Raman noise and Raman gain spectrum for each pump. However, in 5 other embodiments the total output power of the pump 35 is higher than the total output power of the pump 14.

The outputs of the two sub-pumps 36, 37 are coupled together and transmitted on remote pump fiber 15.

The gain spectrum resulting from a two wavelength 10 source such as the optical pump 35 is given by:

$$G(\lambda) = e^{[g(\lambda-\lambda_1)P_1 \frac{L}{A} + g(\lambda-\lambda_2)P_2 \frac{L}{A}]}$$

where $G(\lambda)$ is the gain coefficient for the fiber, $g(\lambda-\lambda_1)$ is the spectral gain coefficient due to the first pump, or sub-pump 36, with wavelength λ_1 and power P_1 , and $g(\lambda-\lambda_2)$ is the spectral gain coefficient due to the second pump, 15 or sub-pump 37, with wavelength λ_2 and power P_2 .

Fig. 4 is a graph of the gain coefficient versus wavelength of remote optical fiber 15 pumped with optical pump 35. Curves 44 and 46 are the resulting Raman gain coefficients due to the sub-pumps 36 and 37. Curve 44 is 20 centered around 1553 nm. Curve 46 is centered around 1603 nm.

Curve 48 represents the addition of curves 44 and 46 and is the gain coefficient spectrum derived from the above equation. The spectral peak of curve 48 is C_3 .

25 Curve 32 from Fig. 2 is also shown in Fig. 4 for comparison purposes. As shown, using the same input power, the spectral peak of curve 48, C_3 , is less than the spectral peak of curve 32, C_4 . Therefore, more power can be input into the remote pump fiber 15 using the high- 30 powered pump 35 relative to the high-powered pump 14

before the fiber 15 is subjected to the negative effects of amplified Raman noise.

As described, the spectral peak of the sum of the spectra caused by pumps at two different wavelengths is less than that than it would be if the pumps were at the same wavelength. Since the peak gain coefficient is less and the gain coefficient is exponentially related to gain, the total gain at the Stokes-shifted wavelengths and hence the total noise is reduced. Since the peak gain is reduced, the propensity to further enhance the Stokes-shifted power through internal reflection is also reduced. (B)

What has been described is merely illustrative of the application of the principles of the present invention. Other arrangements and methods can be implemented by those skilled in the art without departing from the spirit and scope of the present invention. Further, the use of the present invention is not limited to using multiple wavelength pumps for the use of providing pumps for erbium doped fibers, but may be applied in all situations where Raman gain limits total power handling capacity of an optical fiber. or

WHAT IS CLAIMED IS:

1 1. An optical pump that is adapted to be coupled to
2 a remote optical fiber which provides pumping power in a
3 remote optical amplifier, comprising:
4 a first optical pump device that generates a first optical
5 light at a first wavelength;
6 a second optical pump device that generates a second
7 optical light at a second wavelength; and
8 a coupler device that couples said first optical pump
9 device and said second optical pump device so that said
10 first optical light and said second optical light are
11 transmitted together on the remote optical fiber.

1 2. The optical pump of claim 1, wherein said first
2 and second optical lights reduce the conversion of optical
3 power from said first and second optical pump devices to
4 Raman noise.

1 3. The optical pump of claim 1, wherein said first
2 and second optical lights reduce the occurrence of Raman
3 noise in the optical fiber.

AMENDED CLAIMS

[received by the International Bureau on 27 March 1998 (27.03.98);
new claims 4-16; remaining claims unchanged (3 pages)]

1 1. An optical pump that is adapted to be coupled
2 to a remote optical fiber which provides pumping power
3 in a remote optical amplifier, comprising:
4 a first optical pump device that generates a first
5 optical light at a first wavelength;
6 a second optical pump device that generates a second
7 optical light at a second wavelength; and
8 a coupler device that couples said first optical pump
9 device and said second optical pump device so that said
10 first optical light and said second optical light are
11 transmitted together on the remote optical fiber.

1 2. The optical pump of claim 1, wherein said first
2 and second optical lights reduce the conversion of
3 optical power from said first and second optical pump
4 devices to Raman noise.

1 3. The optical pump of claim 1, wherein said first
2 and second optical lights reduce the occurrence of Raman
3 noise in the optical fiber.

1 4. The optical pump of claim 1, wherein said
2 first and second optical lights increase the total gain
3 spectrum available in the remote optical amplifier for
4 amplification of signals.

1 5. The optical pump of claim 1, wherein said first
2 wavelength equals approximately 1450 nanometers and said
3 second wavelength equals approximately 1500 nanometers.

1 6. A method of providing pumping power to a remote
2 optical amplifier comprising the steps of:
3 generating a first optical light at a first wavelength;

4 generating a second optical light at a second
5 wavelength; and
6 transmitting said first optical light and said second
7 optical light together on a single remote optical fiber.

1 7. The method of claim 6, further comprising the
2 step of coupling the single remote optical fiber to the
3 remote optical amplifier.

1 8. The method of claim 7, wherein the first
2 wavelength equals approximately 1450 nanometers and the
3 second wavelength equals approximately 1500 nanometers.

1 9. The method of claim 7, wherein a first optical
2 pump device generates the first optical light and a
3 second optical pump device generates the second optical
4 light, and wherein the first and second optical lights
5 reduce the conversion of optical power generated by said
6 first and second optical pump devices to Raman noise.

1 10. The method of claim 7, wherein the first and
2 second optical lights reduce the occurrence of Raman
3 noise in the single remote optical fiber.

1 11. The method of claim 7, wherein the first and
2 second optical lights increase the total gain spectrum
3 available in the remote optical amplifier for the
4 amplification of signals.

1 12. An optical transmission system comprising:
2 an optical fiber that carries a plurality of optical
3 signals;
4 a remote optical amplifier positioned along said
5 optical fiber that amplifies said optical signals;

6 a remote optical fiber coupled to said remote optical
7 amplifier for providing pumping power to said remote
8 optical amplifier; and
9 an optical pump coupled to said remote optical fiber,
10 said remote optical pump comprising:
11 a first optical pump device that generates a first
12 optical light at a first wavelength;
13 a second optical pump device that generates a
14 second optical light at a second wavelength; and
15 a coupler device that couples said first optical
16 pump device and said second optical pump device so that
17 said first optical light and said second optical light
18 are transmitted together on said remote optical fiber.

1 13. The optical transmission system of claim 12,
2 wherein said first wavelength equals approximately 1450
3 nanometers and said second wavelength equals
4 approximately 1500 nanometers.

1 14. The optical transmission system of claim 12,
2 wherein said first and second optical lights reduce the
3 conversion of optical power generated by said first and
4 second optical pump devices to Raman noise.

1 15. The optical transmission system of claim 12,
2 wherein said first and second optical lights reduce the
3 occurrence of Raman noise in said optical fiber.

1 16. The optical transmission system of claim 12,
2 wherein said first and second optical lights increase
3 the total gain spectrum available in said remote optical
4 amplifier for the amplification of signals.

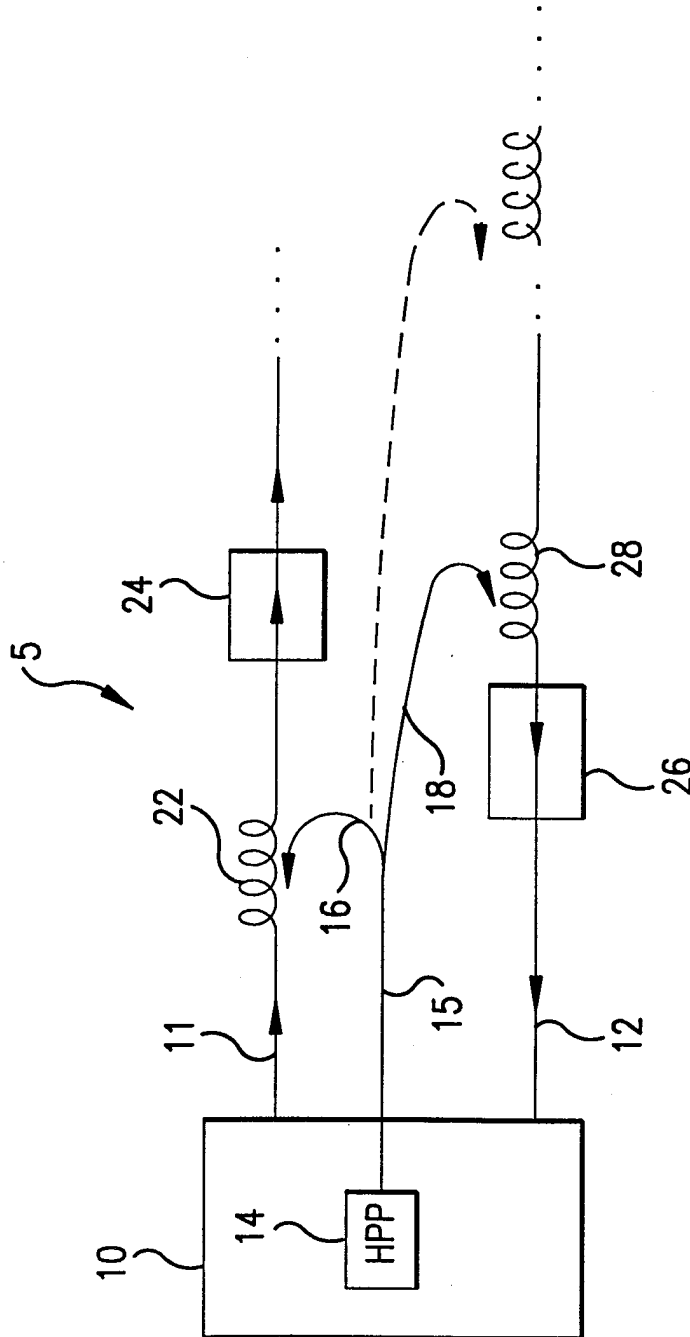

FIG. 1

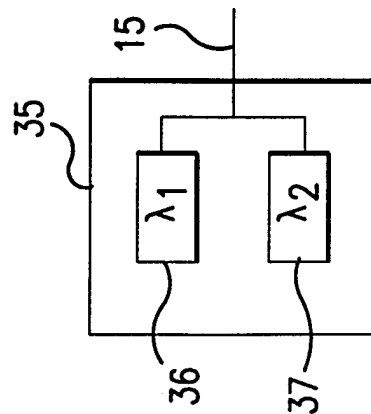
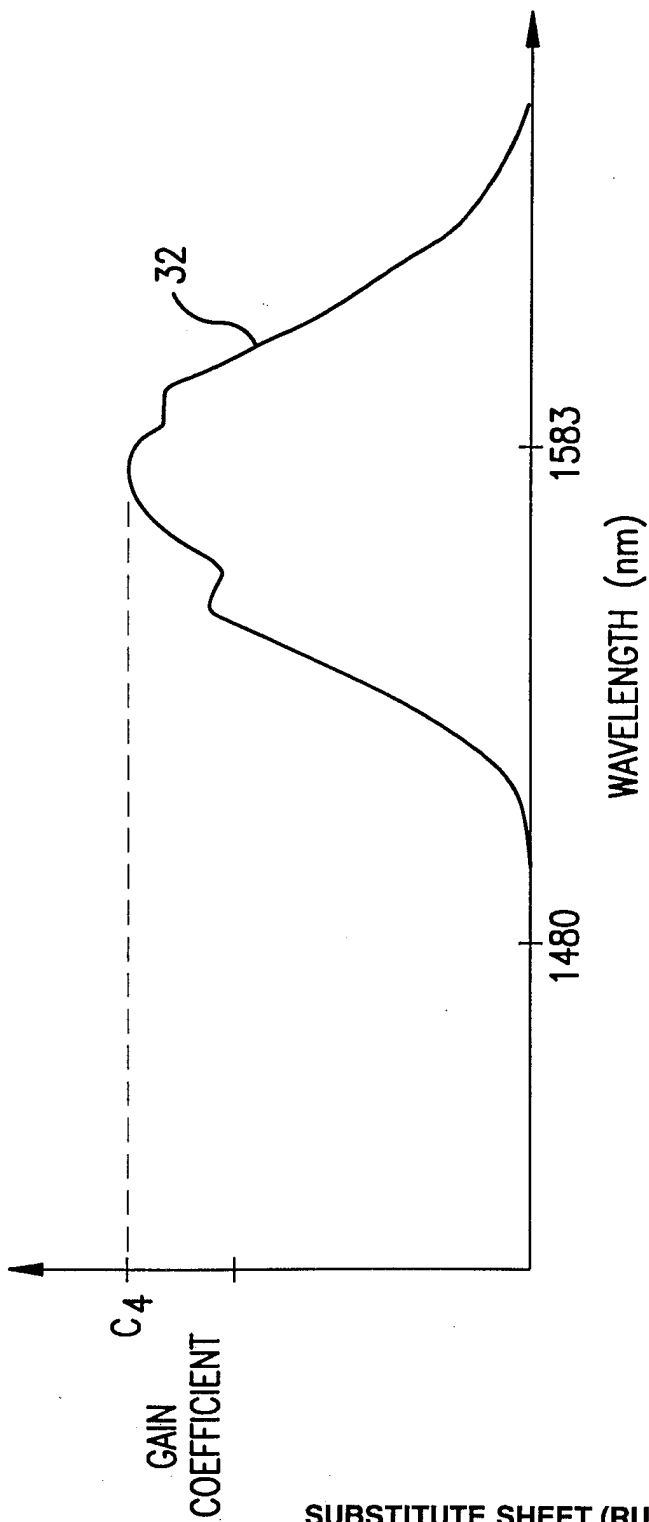

FIG.3

FIG.2

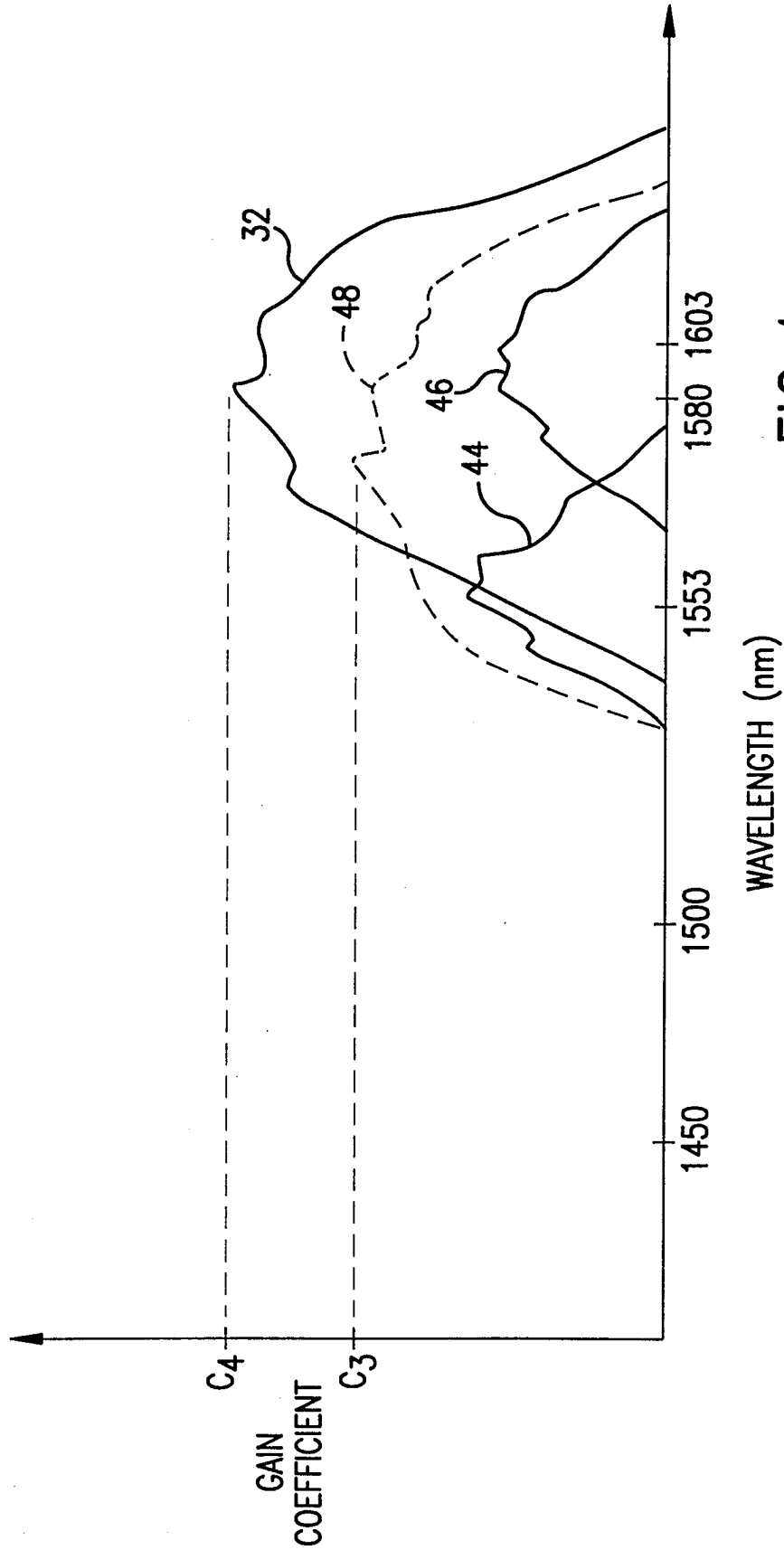

FIG.4

INTERNATIONAL SEARCH REPORT

International application No.
PCT/US97/18436

A. CLASSIFICATION OF SUBJECT MATTER
 IPC(6) :IPC HO1S 3/30
 US CL :372/6
 According to International Patent Classification (IPC) or to both national classification and IPC

B. FIELDS SEARCHED
 Minimum documentation searched (classification system followed by classification symbols)
 U.S. : 372/6,70,3

Documentation searched other than minimum documentation to the extent that such documents are included in the fields searched

Electronic data base consulted during the international search (name of data base and, where practicable, search terms used)

C. DOCUMENTS CONSIDERED TO BE RELEVANT

Category*	Citation of document, with indication, where appropriate, of the relevant passages	Relevant to claim No.
A, P	US 5,659,558 A (TOHMON ET AL) 19 AUGUST 1997 (19/08/97), SEE ENTIRE DOCUMENT	1-3
A	US 5,455,710 A (TAKEDA) 03 OCTOBER 1995 (03/10/95), SEE ENTIRE DOCUMENT	1

Further documents are listed in the continuation of Box C. See patent family annex.

* Special categories of cited documents:	*T* later document published after the international filing date or priority date and not in conflict with the application but cited to understand the principle or theory underlying the invention
A document defining the general state of the art which is not considered to be of particular relevance	*X* document of particular relevance; the claimed invention cannot be considered novel or cannot be considered to involve an inventive step when the document is taken alone
E earlier document published on or after the international filing date	*Y* document of particular relevance; the claimed invention cannot be considered to involve an inventive step when the document is combined with one or more other such documents, such combination being obvious to a person skilled in the art
L document which may throw doubts on priority claim(s) or which is cited to establish the publication date of another citation or other special reason (as specified)	*&* document member of the same patent family
O document referring to an oral disclosure, use, exhibition or other means	
P document published prior to the international filing date but later than the priority date claimed	

Date of the actual completion of the international search 08 DECEMBER 1997	Date of mailing of the international search report 27 JAN 1998
---	---

Name and mailing address of the ISA/US Commissioner of Patents and Trademarks Box PCT Washington, D.C. 20231 Facsimile No. (703) 305-3230	Authorized officer LEON SCOTT JR. <i>[Signature]</i> Telephone No. (703) 308-4884
---	---