



US007401888B2

(12) **United States Patent**
Karppinen et al.

(10) **Patent No.:** **US 7,401,888 B2**

(45) **Date of Patent:** **Jul. 22, 2008**

(54) **METHOD OF MAINTAINING A PRINTHEAD USING MAINTENANCE STATION CONFIGURED FOR AIR BLAST CLEANING**

(75) Inventors: **Vesa Karppinen**, Balmain (AU); **Kia Silverbrook**, Balmain (AU)

(73) Assignee: **Silverbrook Research Pty Ltd**, Balmain, New South Wales (AU)

(*) Notice: Subject to any disclaimer, the term of this patent is extended or adjusted under 35 U.S.C. 154(b) by 353 days.

(21) Appl. No.: **11/246,696**

(22) Filed: **Oct. 11, 2005**

(65) **Prior Publication Data**

US 2007/0080988 A1 Apr. 12, 2007

(51) **Int. Cl.**
B41J 2/165 (2006.01)

(52) **U.S. Cl.** **347/25; 347/29; 347/30; 347/32**

(58) **Field of Classification Search** **347/22, 347/25, 28, 29, 30, 32**

See application file for complete search history.

(56) **References Cited**

U.S. PATENT DOCUMENTS

5,559,536 A * 9/1996 Saito et al. 347/25

FOREIGN PATENT DOCUMENTS

DE	20318248	U1	4/2004
EP	362897	B1	2/1997
EP	1470922	A2	10/2004
JP	2003001858	A	1/2003
JP	2003326739	A	11/2003
JP	2004058348	A	2/2004
JP	2005225163	A	8/2005

* cited by examiner

Primary Examiner—Shih-Wen Hsieh

(57) **ABSTRACT**

A method of maintaining a printhead in an operable condition is provided. The method comprises the steps of: (i) providing a printhead maintenance station comprising a capper having a constriction member, a vacuum system in fluid communication with the capper, an air inlet valve in fluid communication with the capper, and an engagement; (ii) moving the capper into a first position such that the capper is sealingly engaged around the printhead and the constriction member is spaced apart from the face, thereby defining a blast channel; (iii) generating a vacuum over the face using the vacuum system, thereby purging ink from printhead nozzles onto the face; and (iv) opening the air inlet valve, thereby blasting air through the blast channel and removing ink from the face.

17 Claims, 5 Drawing Sheets

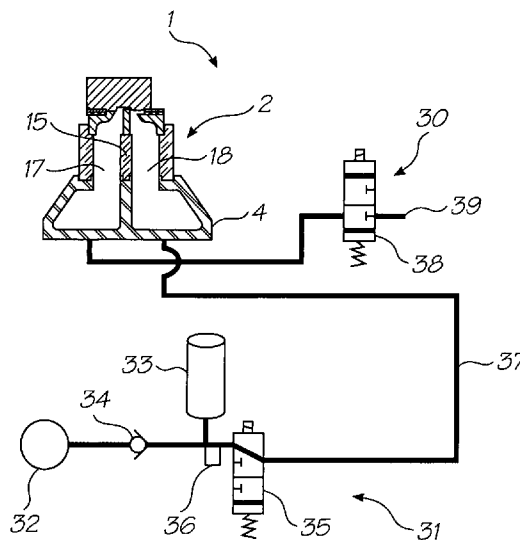
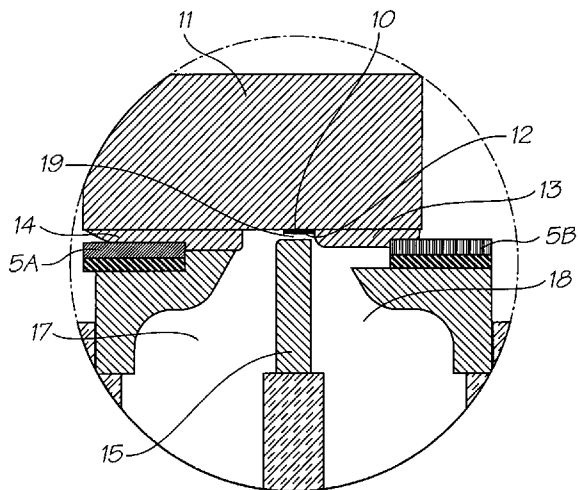

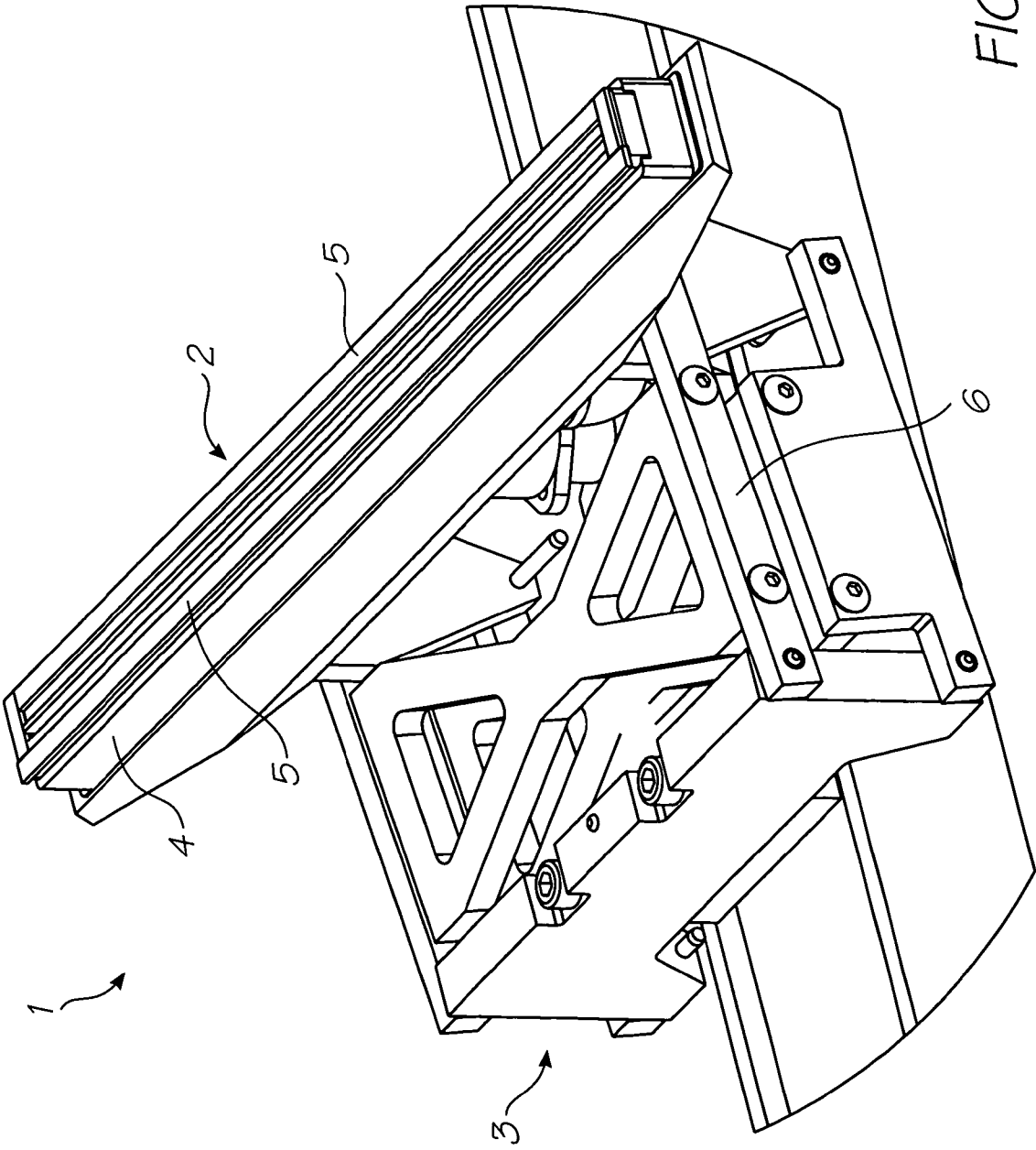

FIG. 1

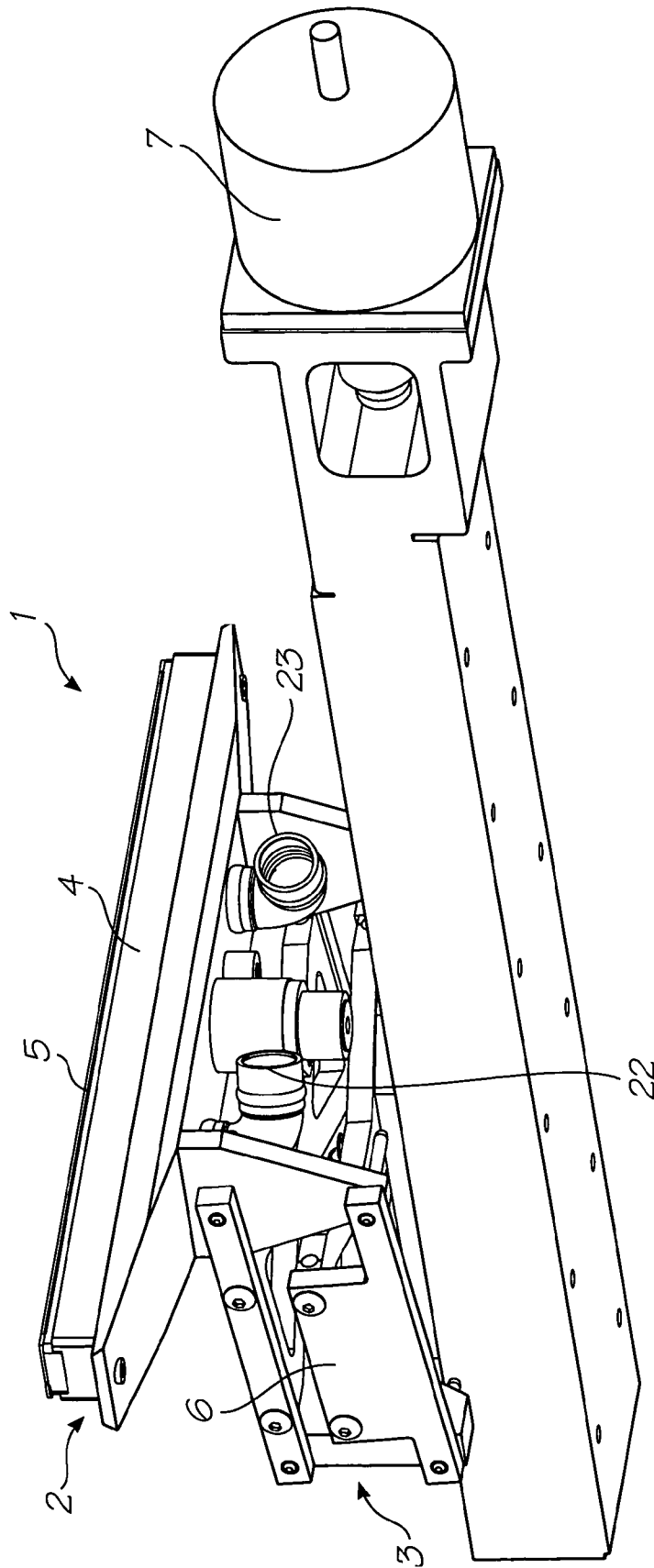

FIG. 2

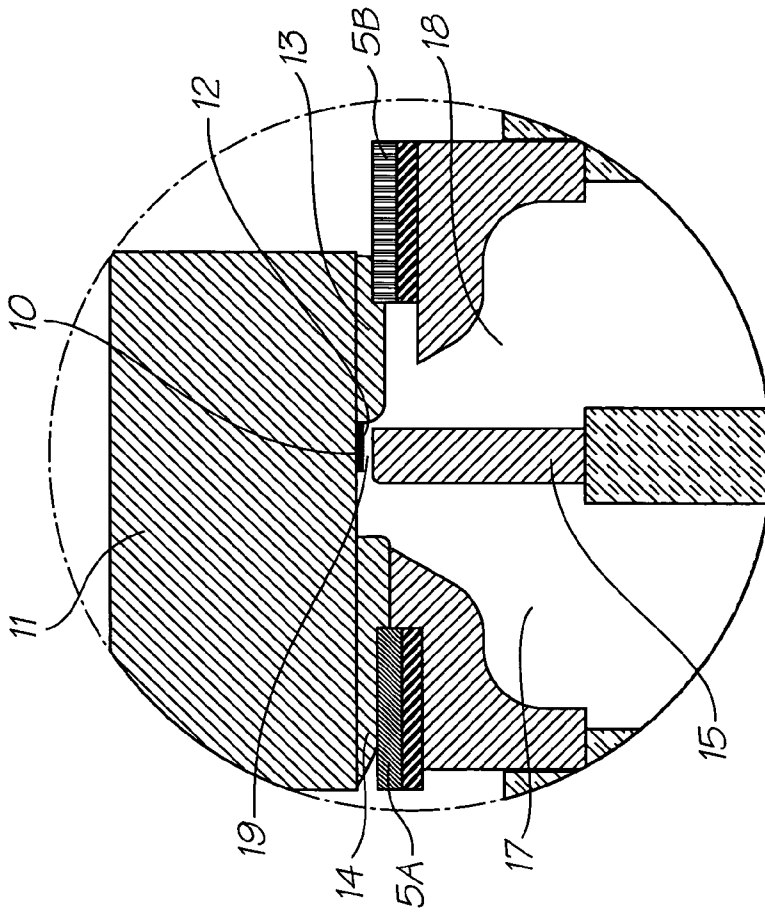

FIG. 4

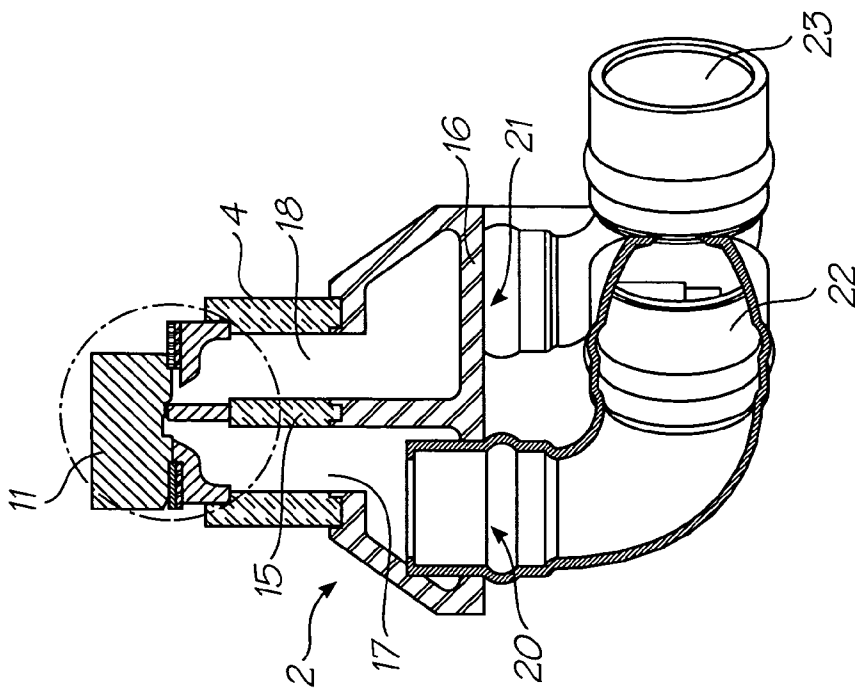

FIG. 3

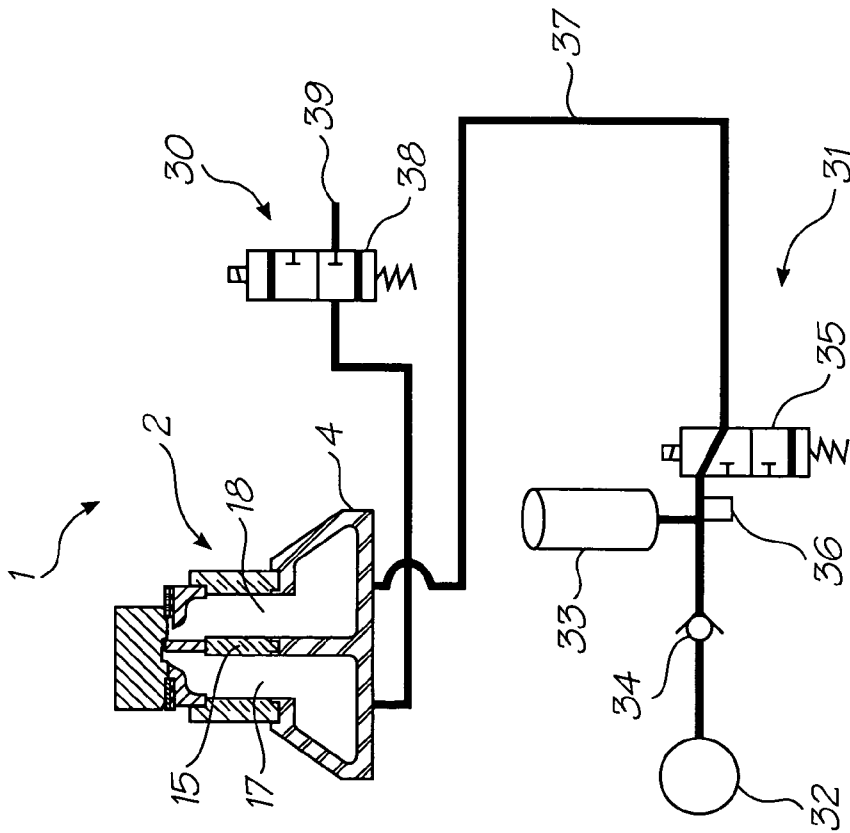

FIG. 5

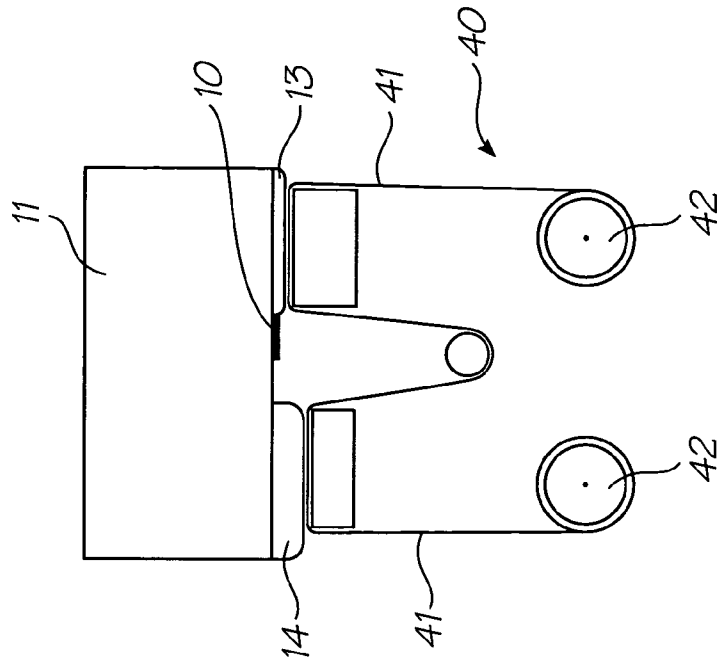

FIG. 6

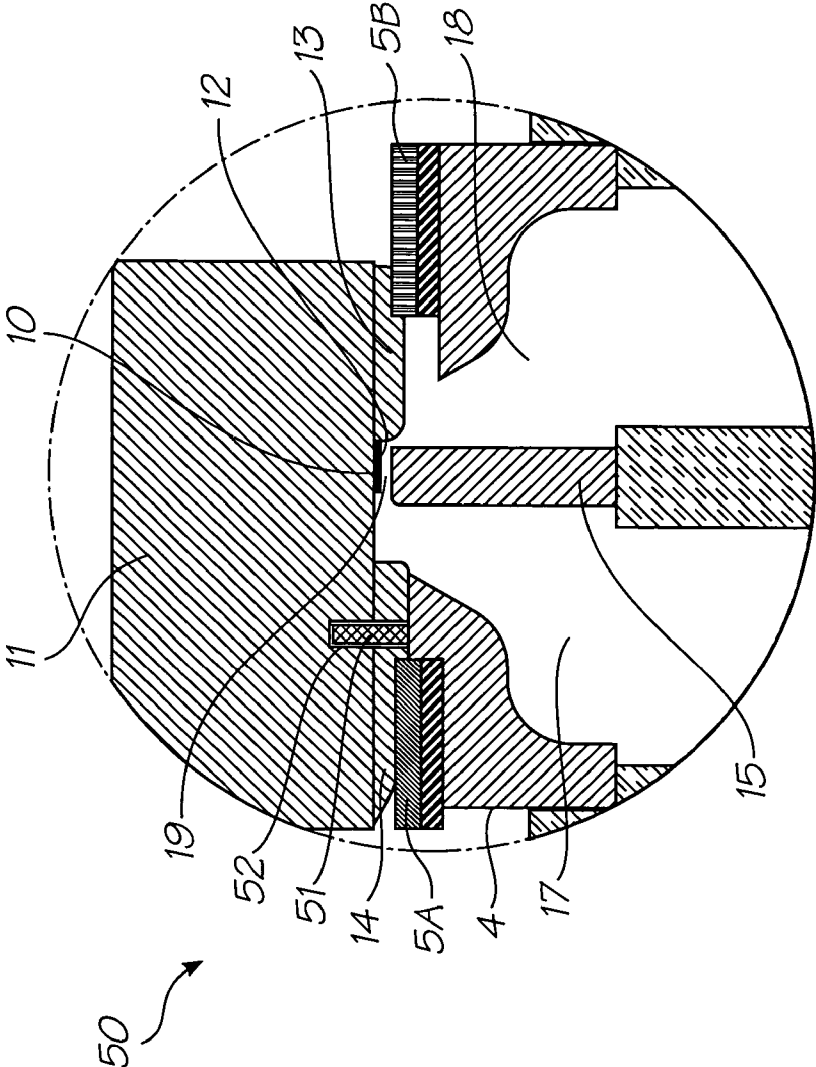

FIG. 7

**METHOD OF MAINTAINING A PRINTHEAD
USING MAINTENANCE STATION
CONFIGURED FOR AIR BLAST CLEANING**

FIELD OF THE INVENTION

this invention relates to a printhead maintenance assembly for an inkjet printhead. It has been developed primarily for facilitating maintenance operations, such as cleaning particulates form an ink ejection face of the printhead.

-pending Applications

The following applications have been filed by the Applicant simultaneously with the present application:

11/246676	11/246677	11/246678	11/246679	11/246680
11/246681	11/246714	11/246713	11/246689	11/246671
11/246670	11/246669	11/246704	11/246710	11/246688
11/246716	11/246715	11/246687	11/246718	7322681
11/246686	11/246703	11/246691	11/246711	11/246690
11/246712	11/246717	11/246709	11/246700	11/246701
11/246702	11/246668	11/246697	11/246698	11/246699
11/246675	7303930	11/246672	11/246673	11/246683
11/246682	11/246707	11/246706	11/246705	11/246708
11/246692	11/246693	11/246695	11/246694	11/246674
11/246667				

The disclosures of these co-pending applications are incorporated herein by reference.

Cross References to Related Applications

Various methods, systems and apparatus relating to the present invention are disclosed in the following US Patents/ Patent Applications filed by the applicant or assignee of the present invention:

6750901	6476863	6788336	7249108	6566858	6331946
6246970	6442525	09/517384	09/505951	6374354	7246098
6816968	6757832	6334190	6745331	7249109	7197642
7093139	10/636263	10/636283	10/866608	7210038	10/902883
10/940653	10/942858	11/003786	7258417	7293853	11/003334
7270395	11/003404	11/003419	11/003700	7255419	7284819
7229148	7258416	7273263	7270393	6984017	11/003699
11/071473	11/003463	11/003701	11/003683	11/003614	7284820
11/003684	7246875	7322669	6623101	6406129	6505916
6457809	6550895	6457812	7152962	6428133	7204941
7282164	10/815628	7278727	10/913373	10/913374	10/913372
7138391	7153956	10/913380	10/913379	10/913376	7122076
7148345	11/172816	11/172815	11/172814	10/407212	7252366
10/683064	10/683041	6746105	7156508	7159972	7083271
7165834	7080894	7201469	7090336	7156489	10/760233
10/760246	7083257	7258422	7255423	7219980	10/760253
10/760255	10/760209	7118192	10/760194	7322672	7077505
7198354	7077504	10/760189	7198355	10/760232	7322676
7152959	7213906	7178901	7222938	7108353	7104629
7246886	7128400	7108355	6991322	7287836	7118197
10/728784	10/728783	7077493	6962402	10/728803	7147308
10/728779	7118198	7168790	7172270	7229155	6830318
7195342	7175261	10/773183	7108356	7118202	10/773186
7134744	10/773185	7134743	7182439	7210768	10/773187
7134745	7156484	7118201	7111926	10/773184	7018021
11/060751	11/060805	11/188017	11/097308	11/097309	7246876
11/097299	11/097310	11/097213	11/210687	11/097212	7147306
09/575197	7079712	6825945	09/575165	6813039	6987506
7038797	6980318	6816274	7102772	09/575186	6681045
6728000	7173722	7088459	09/575181	7068382	7062651
6789194	6789191	6644642	6502614	6622999	6669385
6549935	6987573	6727996	6591884	6439706	6760119
7295332	6290349	6428155	6785016	6870966	6822639

-continued

6737591	7055739	7233320	6830196	6832717	6957768
09/575172	7170499	7106888	7123239	10/727181	10/727162
10/727163	10/727245	7121639	7165824	7152942	10/727157
7181572	7096137	7302592	7278034	7188282	10/727159
10/727180	10/727179	10/727192	10/727274	10/727164	10/727161
10/727198	10/727158	10/754536	10/754938	10/727227	10/727160
10/934720	7171323	10/296522	6795215	7070098	7154638
6805419	6859289	6977751	6398332	6394573	6622923
10/647760	6921144	10/884881	7092112	7192106	11/039866
7173739	6986560	7008033	11/148237	7195328	7182422
10/854521	10/854522	10/854488	7281330	10/854503	10/854504
10/854509	7188928	7093989	10/854497	10/854495	10/854498
10/854511	10/854512	10/854525	10/854526	10/854516	7252353
10/854515	7267417	10/854505	10/854493	7275805	7314261
10/854490	7281777	7290852	10/854528	10/854523	10/854527
10/854524	10/854520	10/854514	10/854519	10/854513	10/854499
10/854501	7266661	7243193	10/854518	10/854517	10/934628
7163345	10/760254	10/760210	10/760202	7201468	10/760198
10/760249	7234802	7303255	7287846	7156511	10/760264
7258432	7097291	10/760222	10/760248	7083273	10/760192
10/760203	10/760204	10/760205	10/760206	10/760267	10/760270
7198352	10/760271	7303251	7201470	7121655	7293861
7232208	10/760186	10/760261	7083272	11/014764	11/014763
11/014748	11/014747	11/014761	11/014760	11/014757	7303252
7249822	11/014762	7311382	11/014723	11/014756	11/014736
11/014759	11/014758	11/014725	11/014739	11/014738	11/014737
7322684	7322685	7311381	7270405	7303268	11/014735
11/014734	11/014719	11/014750	11/014749	7249833	11/014769
11/014729	11/014743	11/014733	7300140	11/014755	11/014765
11/014766	11/014740	7284816	7284845	7255430	11/014744
11/014741	11/014768	7322671	11/014718	11/014717	11/014716
11/014732	11/014742	11/097268	11/097185	11/097184	

The disclosures of these applications and patents are incorporated herein by reference.

BACKGROUND OF THE INVENTION

Inkjet printers are commonplace in homes and offices. However, all commercially available inkjet printers suffer from slow print speeds, because the printhead must scan across a stationary sheet of paper. After each sweep of the printhead, the paper advances incrementally until a complete printed page is produced.

It is a goal of inkjet printing to provide a stationary page-width printhead, whereby a sheet of paper is fed continuously past the printhead, thereby increasing print speeds greatly. The present Applicant has developed many different types of pagewidth inkjet printheads using MEMS technology, some of which are described in the patents and patent applications listed in the above cross reference list.

The contents of these patents and patent applications are incorporated herein by cross-reference in their entirety.

Notwithstanding the technical challenges of producing a pagewidth inkjet printhead, a crucial aspect of any inkjet printing is maintaining the printhead in an operational printing condition throughout its lifetime. A number of factors may cause an inkjet printhead to become non-operational and it is important for any inkjet printer to include a strategy for preventing printhead failure and/or restoring the printhead to an operational printing condition in the event of failure. Printhead failure may be caused by, for example, printhead face flooding, dried-up nozzles (due to evaporation of water from the nozzles—a phenomenon known in the art as decap), or particulates fouling nozzles.

Particulates, in the form of paper dust, are a particular problem in high-speed pagewidth printing. This is because the paper is typically fed at high speed over a paper guide and past the printhead. Frictional contact of the paper with the paper guide generates large quantities of paper dust compared

to traditional scanning inkjet printheads, where paper is fed much more slowly. Hence, pagewidth printheads tend to accumulate paper dust on their ink ejection face during printing. This accumulation of paper dust is highly undesirable.

In the worst case scenario, paper dust blocks nozzles on the printhead, preventing those nozzles from ejecting ink. More usually, paper dust overlies nozzles and partially covers nozzle apertures. Nozzle apertures that are partially covered or blocked produce misdirected ink droplets during printing—the ink droplets are deflected from their intended trajectory by particulates on the ink ejection face. Misdirects are highly undesirable and may result in acceptably low print quality.

One measure that has been used for maintaining printheads in an operational condition is sealing the printhead, which prevents the ingress of particulates and also prevents evaporation of ink from nozzles. Commercial inkjet printers are typically supplied with a sealing tape across the printhead, which the user removes when the printer is installed for use. The sealing tape protects the primed printhead from particulates and prevents the nozzles from drying up during transit. Sealing tape also controls flooding of ink over the printhead face.

Aside from one-time use sealing tape on new printers, sealing has also been used as a strategy for maintaining printheads in an operational condition during printing. In some commercial printers, a gasket-type sealing ring and cap engages around a perimeter of the printhead when the printer is idle. A vacuum may be connected to the sealing cap and used to suck ink from the nozzles, unblocking any nozzles that have dried up. However, whilst sealing/vacuum caps may prevent the ingress of particulates from the atmosphere, such measures do not remove particulates already built up on the printhead.

In order to remove flooded ink from a printhead after vacuum flushing, prior art maintenance stations typically employ a rubber squeegee, which is wiped across the printhead. Particulates are removed from the printhead by flotation into the flooded ink and the squeegee removes the flooded ink having particulates dispersed therein.

However, rubber squeegees have several shortcomings when used with MEMS pagewidth printheads. A typical MEMS printhead has a nozzle plate comprised of a hard, durable material such as silicon nitride, silicon oxide, aluminium nitride etc. Moreover, the nozzle plate is typically relatively abrasive due to etched features on its surface. On the one hand, it is important to protect the nozzle plate, comprising sensitive nozzle structures, from damaging exposure to the shear forces exerted by a rubber squeegee. On the other hand, it is equally important that a rubber squeegee should not be damaged by contact with the printhead and reduce its cleaning efficacy.

Therefore, it would be desirable to provide an inkjet printhead maintenance station, which does not rely on a rubber squeegee wiping across the nozzle plate to remove flood ink and particulates. It would further be desirable to provide an inkjet printhead maintenance station, which removes flooded ink and particulates from the nozzle plate without the nozzle plate coming into contact with any cleaning surface.

It would further be desirable to provide an ink jet printhead maintenance station that is simple in design, does not consume large amounts power and can be readily incorporated into a desktop printer.

SUMMARY OF THE INVENTION

In a first aspect, there is provided a method of maintaining a printhead in an operable condition, said method comprising the steps of:

(a) flooding an ink ejection face of said printhead with ink; and

(b) removing said ink by blasting air across said face.

In a second aspect, there is provided a printhead maintenance station for maintaining a printhead in an operable condition, said maintenance station comprising:

a capper sealingly engageable around said printhead, said capper comprising a constriction member for defining a blast channel adjacent an ink ejection face of said printhead;

an air inlet valve in fluid communication with said capper; and a vacuum system in fluid communication with said capper; and

an engagement mechanism for moving said capper between a first position in which said capper is sealingly engaged around said printhead and a second position in which said capper is disengaged from around said printhead.

In a third aspect, there is provided a method of maintaining a printhead in an operable condition, said method comprising the steps of:

(i) providing a printhead maintenance station, said maintenance station comprising:

a capper sealingly engageable around said printhead, said capper comprising a constriction member for defining a blast channel adjacent an ink ejection face of said printhead;

a vacuum system in fluid communication with said capper; an air inlet valve in fluid communication with said capper; and

an engagement mechanism for moving said capper between a first position in which said capper is sealingly engaged around said printhead and a second position in which said capper is disengaged from around said printhead;

(ii) moving said capper into said first position such that said constriction member is spaced apart from said face, thereby defining said blast channel;

(iii) generating a vacuum over said face using said vacuum system, thereby purging ink from printhead nozzles onto said face; and

(iv) opening said air inlet valve, thereby blasting air through said blast channel and removing ink from said face.

In a fourth aspect, there is provided a printhead maintenance assembly comprising:

a printhead; and a printhead maintenance station for maintaining said printhead in an operable condition, said maintenance station comprising:

a capper sealingly engageable around said printhead, said capper comprising a constriction member for defining a blast channel adjacent an ink ejection face of said printhead;

an air inlet valve in fluid communication with said capper; a vacuum system in fluid communication with said capper; and

an engagement mechanism for moving said capper between a first position in which said capper is sealingly engaged around said printhead and a second position in which said capper is disengaged from around said printhead.

In a fifth aspect, there is provided a capper for a printhead maintenance station, said capper comprising:

a capping chamber sealingly engageable around a printhead;

5

a constriction member positioned in said capper chamber, said constriction member dividing said capper chamber into an air inlet channel and a vacuum channel, said constriction member also defining a blast channel adjacent an ink ejection face of said printhead when said capping chamber is sealingly engaged around said printhead;

an air inlet defined in a wall of said capping chamber, said air inlet opening into said air inlet channel; and

a vacuum aperture defined in a wall of said capping chamber, said vacuum aperture opening into said vacuum channel.

The maintenance station and method of the present application advantageously provide total maintenance of the printhead, including purging decapped nozzles and removing flooded ink on the ink ejection face after the purge. It is particularly advantageous that a separate squeegee-cleaning mechanism is not required to clean flooded ink from the printhead face—both purging and cleaning are performed with the capper engaged around the printhead, which simplifies printhead maintenance operations.

Moreover, the maintenance station and method of the present application advantageously avoid potentially damaging contact of the printhead with an external cleaning device. Hence, unlike prior art squeegee-cleaning methods, the air blasting employed by the present invention does not impart significant shear forces across the printhead and does not damage sensitive MEMS nozzle structures.

In some embodiments of the invention, the air blast is provided without the need for high-powered pumps. By providing a constricted blast channel adjacent the printhead, a high velocity of air flow is generated. Furthermore, the use of a vacuum reservoir, which is charged during purging and discharged during air blasting, further reduces the power requirements of the vacuum system. With such low power requirements, the maintenance station of the present application may be readily incorporated into desktop printers, such as pagewidth inkjet printers.

Optionally, the face is flooded by suction, which purges ink from nozzles in the printhead. The suction purges nozzles which may have become blocked or decapped, flooding the ink onto the ink ejection face of the printhead.

Typically, suction is provided via a capper, which is sealingly engaged around the printhead during printhead maintenance. A perimeter gasket (e.g. rubber gasket) on the capper may be provided for sealing engagement around the printhead. The capper typically takes the form of an elongate capping chamber which can seal around the entire printhead. The capping chamber optionally has an air inlet and a vacuum aperture defined in a wall thereof. The air inlet communicates with an air inlet valve while the vacuum aperture communicates with the vacuum system. The vacuum system optionally comprises a vacuum pump, and is used to flood the ink ejection face by generating a vacuum above the face.

Optionally, air is blasted through a blast channel adjacent the ink ejection face. Typically, the blast channel is defined by a constriction member spaced apart from the face. The constriction member provides a constricted blast channel, which has the effect of accelerating air flow across the ink ejection face according to Bernoulli's law. Optionally, air flow rates of 2 to 10, 3 to 8 or 5 to 7 litres per second may be provided. Optionally, the constriction member is spaced less than 2 mm, less than 1 mm, less than 0.5 mm or less than 0.3 mm from the ink ejection face.

Optionally, the constriction member is substantially coextensive with the printhead, ensuring that the whole length of the printhead receives an air blast across its width.

Typically, the constriction member forms part of the capper so that the capper can perform the dual functions of suction

6

purging and air blasting. Optionally, the constriction member divides the capping chamber into an air inlet channel and a vacuum channel.

Optionally, air is blasted through the blast channel by releasing a vacuum above the printhead to the atmosphere. This is usually achieved by opening an air inlet valve in fluid communication with the capper so that air rushes into the capper via an air inlet channel and blasts through the blast channel into a vacuum channel.

Optionally, the vacuum system and the air inlet valve are arranged to control a direction of air flow through the blast channel. For example, by suitable positioning of an air inlet valve connection and vacuum connection on the capper, the air flow through the blast channel may be varied. Optionally, air flows transversely across the printhead face. Optionally, the air flow buffets into a wire bond encapsulant bonded along a longitudinal edge of the printhead. An advantage of this arrangement is that it minimizes the risk of ink becoming trapped in a 'dead space' where the encapsulant meets the printhead.

Optionally, the vacuum system further comprises a vacuum reservoir. The reservoir is charged with a vacuum either before or during suction purging of the printhead nozzles. During air blasting the vacuum reservoir is discharged. Accordingly, the vacuum reservoir advantageously allows a high velocity air flow through the blast channel, without the need for a high-powered vacuum pump.

Optionally, the vacuum system further comprises an ink dump for receiving ink removed from the ink ejection face during air blasting. The vacuum system typically directs the removed ink into the ink dump during air blasting. In some embodiments, the ink dump may be contained in the vacuum reservoir.

Optionally, the printhead is mounted on a support, which typically comprises an ink manifold for supplying ink to the printhead. Optionally, the support may further comprise a wirebond encapsulant bonded to the ink manifold and/or a paper guide attached to the ink manifold. Optionally, the capper sealingly engages with the support.

Optionally, the support and the capper comprise complementary alignment features for locating the capper into a printhead maintenance position. The alignment features advantageously ensure proper alignment of the capper around the printhead and, in particular, proper positioning of the constriction member so as to define the blast channel.

Optionally, the capper is disengaged from around the printhead after each maintenance cycle of purging and air blasting. Optionally, an area around the printhead is dabbed after disengagement of the capper, using a dabbing device. The dabbing device may comprise, for example, a microfibre film or an absorbent block of wicking material. Dabbing may be used to remove any ink from around the printhead (e.g. on wire bond encapsulant or on a printhead support), which has not been removed by the air blasting.

The invention has been developed primarily for use with a MEMS pagewidth inkjet printhead. However, the invention is equally applicable to any type of printhead where remedial measures are required to maintain the printhead in an operable condition. For example, the invention may be used in connection with standard scanning inkjet printheads in order to avoid printhead damage during maintenance.

In a first aspect the present invention provides a printhead maintenance assembly for maintaining a printhead in an operable condition, said maintenance assembly comprising:

7

(i) a printhead assembly comprising:
 a printhead having an ink ejection face, said face having a first edge portion and a second edge portion opposite said first edge portion; and
 a film guide sealingly bonded to said first edge portion, said film guide being positioned to guide a film through a transfer zone, said transfer zone being defined by a plane spaced apart from said face; and

(ii) an ink transport assembly comprising:
 a film for transporting ink away from said printhead; and
 a transport mechanism for feeding said film through said transfer zone and away from said printhead, said transport mechanism feeding said film in a directional sense which is from said first edge portion to said second edge portion;

wherein, in use, said film contacts with said film guide thereby forming a cavity defined at least partially by said film, said film guide and said face.

Optionally, said printhead is a pagewidth inkjet printhead. Optionally, said first and second edge portions are longitudinal edge portions.

Optionally, said film guide is comprised of a solid polymeric material.

Optionally, said film guide encapsulates wire bonds extending from said first edge portion of said printhead.

Optionally, said transfer zone is substantially parallel with said ink ejection face.

Optionally, said transfer zone is less than 1 mm from said face.

Optionally, said film is wetting.

Optionally, said film is an endless loop.

Optionally, a width of said film is substantially coextensive with a length of said printhead.

Optionally, said ink transport assembly further comprises a film cleaner, said transport mechanism being configured to feed said film past said film cleaner.

Optionally, said film cleaner is an absorbent pad positioned remotely from said printhead.

Optionally, said cavity is open-ended at said second edge portion.

Optionally, said ink transport assembly is moveable between a first position in which said film is positioned in said transfer zone and a second position in which said film is positioned remotely from said transfer zone.

In a further aspect there is provided a maintenance assembly, further comprising:

(iii) a face flooding system for flooding ink from said printhead onto said ink ejection face.

Optionally, said face flooding system comprises a pressure system for positively pressurizing an ink reservoir supplying ink to said printhead.

Optionally, said pressure system comprises a control system for controlling an amount and/or a period of pressure applied to said ink reservoir.

Optionally, said printhead assembly further comprises a print media guide for guiding print media past said printhead.

Optionally, said print media guide is moveable between a media-guiding position and a retracted position.

Optionally, said print media guide is positioned on an opposite side of said printhead to said film guide.

In a second aspect the present invention provides a method of maintaining a printhead in an operable condition, said method comprising the steps of:

(i) providing a printhead assembly, said printhead assembly comprising:

8

a printhead having an ink ejection face, said face having a first edge portion and a second edge portion opposite said first edge portion; and

a film guide sealingly bonded to said first edge portion, said film guide being positioned to guide a film through a transfer zone, said transfer zone being defined by a plane spaced apart from said face;

(ii) positioning at least part of a film in said transfer zone and in contact with said film guide, thereby forming a cavity defined at least partially by said film, said film guide and said face; and

(iii) feeding said film through said transfer zone and away from said printhead, thereby removing ink from said cavity, said film being fed in a directional sense which is from said first edge portion to said second edge portion.

Optionally, said printhead is a pagewidth inkjet printhead. Optionally, said first and second edge portions are longitudinal edge portions.

Optionally, said film guide is comprised of a solid polymeric material.

Optionally, said film guide encapsulates wire bonds extending from said first edge portion of said printhead.

Optionally, said transfer zone is substantially parallel with said ink ejection face.

Optionally, said transfer zone is less than 2 mm from said face.

Optionally, said film is wetting.

Optionally, said film is an endless loop.

Optionally, a width of said film is substantially coextensive with a length of said printhead.

Optionally, said film is fed past a film cleaner after being fed through said transfer zone.

Optionally, said film cleaner is an absorbent pad positioned remotely from said printhead.

Optionally, said cavity is open-ended at said second edge portion.

Optionally, said film is moveable between a first position in which said film is positioned in said transfer zone and a second position in which said film is positioned remotely from said transfer zone

Optionally, said face is flooded with ink from said printhead prior to feeding said film through said transfer zone.

Optionally, said face is flooded by positively pressurizing an ink reservoir supplying ink to said printhead.

Optionally, an amount and/or a period of pressure applied to said ink reservoir is controlled.

Optionally, said printhead assembly further comprises a print media guide for guiding print media past said printhead.

Optionally, said print media guide is moved out of a media-guiding position prior to positioning said film in said transfer zone.

Optionally, said print media guide is moved into a media-guiding position after feeding said film through said transfer zone.

In a third aspect the present invention provides a method of removing flooded ink from an ink ejection face of a printhead, said method comprising transferring said ink onto a film moving past said face, wherein said film does not contact said face.

Optionally, said film is guided past said face using a film guide.

Optionally, at least part of said face, said film and said film guide form a cavity for containing said ink.

Optionally, said cavity is open-ended.

Optionally, said printhead is a pagewidth inkjet printhead.

Optionally, said film guide is comprised of a solid polymeric material.

Optionally, said film guide encapsulates wire bonds extending from said printhead.

Optionally, said film is moved past said face substantially parallel therewith.

Optionally, said film is less than 2 mm from said face.

Optionally, said film is wetting.

Optionally, a width of said film is substantially coextensive with a length of said printhead.

Optionally, said film is fed past a film cleaner after being fed past said face.

Optionally, said film cleaner is an absorbent pad positioned remotely from said printhead.

Optionally, ink is flooded across said face prior to moving said film past said face

Optionally, said face is flooded by positively pressurizing an ink reservoir supplying ink to said printhead.

Optionally, an amount and/or a period of pressure applied to said ink reservoir is controlled.

In a fourth aspect the present invention provides a method of removing particulates from an ink ejection face of a printhead, said method comprising the steps of:

- (a) flooding said face with ink from said printhead, thereby dispersing said particulates into said flooded ink; and
- (b) transferring said flooded ink, including said particulates, onto a film moving past said face,

wherein said film does not contact said face.

Optionally, said film is guided past said face using a film guide.

Optionally, at least part of said face, said film and said film guide form a cavity for containing said ink.

Optionally, said cavity is open-ended.

Optionally, said printhead is a pagewidth inkjet printhead.

Optionally, said film guide is comprised of a solid polymeric material.

Optionally, said film guide encapsulates wire bonds extending from said printhead.

Optionally, said film is moved past said face substantially parallel therewith.

Optionally, said film is less than 2 mm from said face.

Optionally, said film is wetting.

Optionally, a width of said film is substantially coextensive with a length of said printhead.

Optionally, said film is fed past a film cleaner after being fed past said face.

Optionally, said film cleaner is an absorbent pad positioned remotely from said printhead.

Optionally, said face is flooded with ink by positively pressurizing an ink reservoir supplying ink to said printhead.

Optionally, an amount and/or a period of pressure applied to said ink reservoir is controlled.

In a fifth aspect the present invention provides a method of maintaining a printhead in an operable condition, said method comprising the steps of:

- (a) flooding an ink ejection face of said printhead with ink; and
- (b) removing said ink by blasting air across said face.

Optionally, said face is flooded by suction.

Optionally, said suction purges nozzles in said printhead.

Optionally, a capper is sealingly engaged around said printhead during printhead maintenance.

Optionally, said capper is disengaged from around said printhead during printing.

Optionally, said capper comprises a perimeter gasket for sealing engagement around said printhead.

Optionally, said capper is in fluid communication with a vacuum system, said vacuum system flooding said face by generating a vacuum above said face.

Optionally, said vacuum system comprises a vacuum pump.

Optionally, air is blasted through a blast channel adjacent said face.

Optionally, said blast channel is defined by a constriction member spaced apart from said face, said constriction member constricting air flow across said face.

Optionally, said constriction member is substantially coextensive with said printhead.

Optionally, said capper comprises a constriction member, said constriction member defining a blast channel adjacent said printhead when said capper is engaged around said printhead.

Optionally, air is blasted through said blast channel by releasing said vacuum to atmosphere.

Optionally, said capper is in fluid communication with an air inlet valve, said vacuum system, said constriction member and said air inlet valve cooperating to blast air through said blast channel.

Optionally, said vacuum system and said air inlet valve are arranged to control a direction of air flow through said blast channel.

Optionally, said vacuum system further comprises a vacuum reservoir, said reservoir being charged before flooding of said face.

Optionally, said reservoir is discharged during air blasting.

Optionally, said vacuum system further comprises an ink dump for receiving ink removed from said face during said air blast.

Optionally, said vacuum system directs said removed ink into said ink dump during air blasting.

Optionally, said printhead is a pagewidth inkjet printhead.

In a sixth aspect the present invention provides a printhead maintenance station for maintaining a printhead in an operable condition, said maintenance station comprising:

a capper sealingly engageable around said printhead, said capper comprising a constriction member for defining a blast channel adjacent an ink ejection face of said printhead;

an air inlet valve in fluid communication with said capper; a vacuum system in fluid communication with said capper; and

an engagement mechanism for moving said capper between a first position in which said capper is sealingly engaged around said printhead and a second position in which said capper is disengaged from around said printhead.

Optionally, said capper comprises a perimeter gasket for sealing engagement around said printhead.

Optionally, said vacuum system comprises a vacuum pump.

Optionally, said vacuum system is configured for generating a vacuum above said face, said vacuum purging ink from printhead nozzles onto said face.

Optionally, in said first position, said constriction member is spaced apart from said face, thereby defining said blast channel.

Optionally, said constriction member is spaced less than 0.5 mm from said face.

Optionally, said constriction member is substantially coextensive with said printhead.

Optionally, said capper comprises an air inlet port and a vacuum port.

11

Optionally, said vacuum system, said air inlet valve and said constriction member cooperate for blasting air through said blast channel, thereby removing ink from said face.

Optionally, said vacuum system and said air inlet valve are arranged to control a direction of air flow through said blast channel.

Optionally, said printhead comprises a wire bond encapsulant along one edge, and said air flow buffets into said encapsulant.

Optionally, said air flows transversely across said face.

Optionally, said vacuum system further comprises a vacuum reservoir.

Optionally, said vacuum system is configured for charging said vacuum reservoir before purging of said printhead nozzles.

Optionally, said vacuum system is configured for discharging said vacuum reservoir during air blasting.

Optionally, said vacuum system further comprises an ink dump for receiving ink removed from said face during said air blasting.

Optionally, said vacuum system is configured for directing said removed ink into said ink dump during air blasting.

Optionally, said printhead is a pagewidth inkjet printhead.

In a seventh aspect the present invention provides a method of maintaining a printhead in an operable condition, said method comprising the steps of:

(i) providing a printhead maintenance station, said maintenance station comprising:

a capper sealingly engageable around said printhead, said capper comprising a constriction member for defining a blast channel adjacent an ink ejection face of said printhead;

a vacuum system in fluid communication with said capper;

an air inlet valve in fluid communication with said capper; and

an engagement mechanism for moving said capper between a first position in which said capper is sealingly engaged around said printhead and a second position in which said capper is disengaged from around said printhead;

(ii) moving said capper into said first position such that said constriction member is spaced apart from said face, thereby defining said blast channel;

(iii) generating a vacuum over said face using said vacuum system, thereby purging ink from printhead nozzles onto said face; and

(iv) opening said air inlet valve, thereby blasting air through said blast channel and removing ink from said face.

Optionally, the method comprising the further step of:

(v) moving said capper into said second position.

Optionally, the method comprising the further step of:

(vi) dabbing ink from around said printhead.

Optionally, said capper comprises a perimeter gasket for sealing engagement around said printhead.

Optionally, said vacuum system comprises a vacuum pump.

Optionally, said constriction member is spaced less than 0.5 mm from said face in said first position.

Optionally, said constriction member is substantially coextensive with said printhead.

Optionally, said vacuum system and said air inlet valve are arranged to control a direction of air flow through said blast channel.

12

Optionally, said printhead comprises a wire bond encapsulant along one edge, and said air flow buffets into said encapsulant.

Optionally, said air flows transversely across said face.

Optionally, said vacuum system further comprises a vacuum reservoir.

Optionally, said vacuum reservoir is charged prior to said purging.

Optionally, said vacuum reservoir is discharged during said air blasting.

Optionally, said vacuum system further comprises an ink dump for receiving ink removed from said face during said air blasting.

Optionally, said vacuum system directs said removed ink into said ink dump during air blasting.

Optionally, said printhead is a pagewidth inkjet printhead.

In an eighth aspect the present invention provides a printhead maintenance assembly comprising:

a printhead; and

a printhead maintenance station for maintaining said printhead in an operable condition, said maintenance station comprising:

a capper sealingly engageable around said printhead, said capper comprising a constriction member for defining a blast channel adjacent an ink ejection face of said printhead;

an air inlet valve in fluid communication with said capper; a vacuum system in fluid communication with said capper; and

an engagement mechanism for moving said capper between a first position in which said capper is sealingly engaged around said printhead and a second position in which said capper is disengaged from around said printhead.

Optionally, said capper comprises a perimeter gasket for sealing engagement around said printhead.

Optionally, said vacuum system comprises a vacuum pump.

Optionally, said vacuum system is configured for generating a vacuum above said face, said vacuum purging ink from printhead nozzles onto said face.

Optionally, in said first position, said constriction member is spaced apart from said face, thereby defining said blast channel.

Optionally, said constriction member is spaced less than 0.5 mm from said face.

Optionally, said constriction member is substantially coextensive with said printhead.

Optionally, said capper comprises an air inlet port and a vacuum port.

Optionally, said vacuum system, said air inlet valve and said constriction member cooperate for blasting air through said blast channel, thereby removing ink from said face.

Optionally, said vacuum system and said air inlet valve are arranged to control a direction of air flow through said blast channel.

Optionally, said printhead comprises a wire bond encapsulant along one edge, and said air flow buffets into said encapsulant.

Optionally, said vacuum system further comprises a vacuum reservoir.

Optionally, said vacuum system is configured for charging said vacuum reservoir before purging of said printhead nozzles.

Optionally, said vacuum system is configured for discharging said vacuum reservoir during air blasting.

13

Optionally, said vacuum system further comprises an ink dump for receiving ink removed from said face during said air blasting.

Optionally, said vacuum system is configured for directing said removed ink into said ink dump during air blasting.

Optionally, said printhead is a pagewidth inkjet printhead.

Optionally, said printhead is mounted on a support.

Optionally, said capper is sealingly engageable with said support.

Optionally, said support and said capper comprise complementary alignment features for locating said capper into said first position.

In a ninth aspect the present invention provides a capper for a printhead maintenance station, said capper comprising:

a capping chamber sealingly engageable around a printhead;

a constriction member positioned in said capper chamber, said constriction member dividing said capper chamber into an air inlet channel and a vacuum channel, said constriction member also defining a blast channel adjacent an ink ejection face of said printhead when said capping chamber is sealingly engaged around said printhead;

an air inlet defined in a wall of said capping chamber, said air inlet opening into said air inlet channel; and a vacuum aperture defined in a wall of said capping chamber, said vacuum aperture opening into said vacuum channel.

Optionally, said capping chamber comprises a perimeter gasket for sealing engagement around said printhead.

Optionally, said air inlet is in fluid communication with an air inlet valve.

Optionally, said vacuum aperture is in fluid communication with a vacuum system.

Optionally, said vacuum system is configured for generating a vacuum above said face, said vacuum purging ink from printhead nozzles onto said face.

Optionally, said constriction member is spaced apart from said face, thereby defining said blast channel, when said capping chamber is engaged around said printhead.

Optionally, said constriction member is spaced less than 0.5 mm from said face.

Optionally, said constriction member is substantially coextensive with said printhead.

Optionally, said vacuum system, said air inlet valve and said constriction member cooperate for blasting air through said blast channel, thereby removing ink from said face.

Optionally, said vacuum system and said air inlet valve are arranged to control a direction of air flow through said blast channel.

Optionally, said printhead comprises a wire bond encapsulant along one edge, and said air flow buffets into said encapsulant.

Optionally, capper further comprising an air inlet port and a vacuum port.

Optionally, said printhead is a pagewidth inkjet printhead.

Optionally, said printhead is mounted on a support.

Optionally, said capping chamber is sealingly engageable with said support.

Optionally, said capping chamber comprises at least one first alignment feature complementary with at least one second alignment feature on said support, said alignment features locating said capping chamber into sealing engagement around said printhead.

14

BRIEF DESCRIPTION OF THE DRAWINGS

Specific forms of the present invention will be now be described in detail, with reference to the following drawings, in which:

FIG. 1 is a front perspective view of a capper and engagement mechanism for a printhead maintenance station according to the present invention;

FIG. 2 is a rear perspective view of the capper and engagement mechanism shown in FIG. 1;

FIG. 3 is a transverse section of the capper engaged with a printhead assembly;

FIG. 4 is an enlarged view of the capper and printhead assembly shown in FIG. 3;

FIG. 5 is a schematic diagram of a fluidics system for the printhead maintenance station;

FIG. 6 is a schematic side view of a dabbing device; and

FIG. 7 is a transverse section of an alternative capper engaged with a printhead assembly.

DETAILED DESCRIPTION OF SPECIFIC EMBODIMENTS

Referring to FIGS. 1 and 2, there is shown part of a printhead maintenance station 1 comprising a capper 2 and an engagement mechanism 3. The capper 2 takes the form of an elongate capping chamber 4 having a perimeter gasket 5 fixed around one end. The capping chamber 4 with gasket 5 is configured to fit and form a seal around a pagewidth printhead 10 (see FIGS. 3 and 4).

In the embodiment shown, the engagement mechanism 3 takes the form of a pantograph 6, which raises and lowers the capper 2 into sealing engagement and out of engagement from around the printhead 10. The pantograph 6 is actuated using a motor 7, which raises and lowers the pantograph via a cam arrangement (not shown). Other types of engagement mechanism suitable for raising and lowering the capper 2 will, of course, be readily apparent to the person skilled in the art.

Referring to FIGS. 3 and 4, the capper 2, engaged around the printhead 10, is shown in more detail. The printhead 10 is mounted on an ink manifold 11, which supplies ink to a backside of the printhead. A wirebond encapsulant 13 is bonded to the ink manifold 11 and extends from one side of the printhead 10. The encapsulant 13 protects wirebonds, which connect CMOS circuitry in the printhead 10 to an external microprocessor (not shown). On an opposite side of the printhead 10, a paper guide 14 is attached to the ink manifold 11. During printing, paper is guided over the paper guide 14 and ink is ejected from an ink ejection face 12 of the printhead 10 onto the paper via a plurality of inkjet nozzles (not shown). The capper 2 is disengaged when the printhead 10 is being used for printing.

As shown in FIG. 4, with the capper 2 in its engaged position, the perimeter gasket 5 forms a seal around the printhead 10. Longitudinal sides 5A and 5B of the perimeter gasket 5 sealingly engage with the paper guide 14 and wirebond encapsulant 13 respectively.

A constriction member 15 extends from a base 16 of the capping chamber 4 towards the printhead 10. The constriction member 15 divides the capper chamber 4 into an air inlet channel 17 and a vacuum channel 18. With the capper 2 engaged around the printhead 10, the air inlet channel 17 and the vacuum channel 18 are in fluid communication via a constricted blast channel 19. The constriction member 15 and

15

the ink ejection face **12** together define the width of the blast channel **19** therebetween. Typically, the blast channel **19** has a width of about 0.2 mm.

An air inlet **20** and a vacuum aperture **21** are defined in the base **16** of the capping chamber **4** and are connected to an air inlet port **22** and vacuum port **23** respectively. The air inlet **20** and vacuum aperture **21** open into the air inlet channel **17** and vacuum channel **18** respectively.

The air inlet port **22** is connected via hose to an air inlet valve **30**, while the vacuum port **23** is connected via a hose to a vacuum system **31**. The air inlet valve **30** and vacuum system **31** cooperate with the capper **2** to purge and clean the printhead **10**. The purging and cleaning operations are described in further detail with reference to FIG. **5**.

Referring to FIG. **5**, the vacuum system **31** comprises a vacuum pump **32** connected to a vacuum reservoir **33**. A check valve **34** between the vacuum pump **32** and the reservoir **33** ensures that the reservoir remains charged after the pump is switched off. The vacuum reservoir **33** is connected to the vacuum channel **18** in the capping chamber **4** via a vacuum line **37** and the vacuum port **23** (not shown in FIG. **5**). A first solenoid valve **35** and an ink dump **36** are positioned in the vacuum line **37** between the vacuum reservoir **33** and the capping chamber **4**.

The air inlet valve **30** takes the form of a second solenoid valve **38**, which is connected to the air inlet channel **17** in the capping chamber **4** via the air inlet port **20** (not shown in FIG. **5**). The air inlet valve **30** has an air intake **39**, which may receive unfiltered or filtered air from the atmosphere.

At the beginning of a typical printhead maintenance operation, the vacuum reservoir **33**, having a volume of about 1 to 1.5 litres, is initially charged with a vacuum. The vacuum reservoir **33** may be charged independently of the capper **2** by switching the first solenoid valve **35** to a charging position (not shown). The vacuum reservoir **33** may, for example, be charged during idle periods or during active printing when the capper **2** is disengaged. The time period for charging the vacuum reservoir **33** may vary, depending on the size of the reservoir and the power of the pump **32**. Typically, charging will last for a maximum of about 45 seconds, ensuring that the printhead can be regularly maintained or remediated.

With the vacuum reservoir **33** charged, the capper **2** is engaged around the printhead **10** and the first solenoid valve **35** is opened to the vacuum reservoir, as shown in FIG. **5**. Since the capper **2** is sealed around the printhead **10**, a negative pressure is generated above the ink ejection face **12** and, as a result, ink floods from printhead nozzles onto the ink ejection face.

Immediately after subjecting the printhead **10** to vacuum (e.g. after about 50 to 500 ms), the second solenoid valve **38** is opened. As a result, air is drawn into the air intake **39** and rushes from the air inlet channel **17** through to the vacuum channel **18** and on into the vacuum system **31**. Air is blasted through the blast channel **19** at high velocity due to the small gap (about 0.2 mm) between the constriction member **15** and the ink ejection face **12**. Typically, the air flow rate through the blast channel **19** is about 5 to 7 litres per second, which ensures complete removal of flooded ink from the ink ejection face **12** of the printhead **10**. Ink removed from the ink ejection face **12** by the air blast is deposited into the ink dump **36**.

With the ink purging and cleaning operation complete, the vacuum reservoir **33** is recharged by the vacuum pump **32** in preparation for the next printhead maintenance cycle.

After air blasting, any ink remaining on areas surrounding the ink ejection face **12** may be removed by a simple dabbing device. FIG. **6** shows a dabbing device **40** comprising a microfibre film **41**, which is fed between a pair of spools **42**.

16

The film **41** is used to dab the paper guide **14** and wirebond encapsulant **13** after disengagement of the capper **2**. After dabbing, the film **41** is advanced so that a clean portion of film is ready for subsequent dabbing.

The printhead maintenance station **1** as described above may be used for maintaining any type of printhead in an operable condition. It is especially suitable for use with page-width MEMS inkjet printheads, where it is desirable to avoid physical contact of the printhead with a cleaning device.

An important aspect of the invention is alignment of the capper **2** with the printhead **10**, so that constriction member **15** is accurately positioned to define the blast channel **19**. FIG. **7** shows an alternative printhead maintenance assembly **50**, wherein the capper **2** and the printhead support have complementary alignment features for aligning the capper into position. Specifically, a locating pin **51** extends from a roof of the capping chamber **4**, and engages with a complementary slot **52** in the paper guide **14**. It will be appreciated that a plurality of such complementary alignment features may be provided to assist in aligning the capper **2** into its optimum maintenance position.

It will, of course, be appreciated that the present invention has been described purely by way of example and that modifications of detail may be made within the scope of the invention, which is defined by the accompanying claims.

The invention claimed is:

1. A method of maintaining a printhead in an operable condition, said method comprising the steps of:

(i) providing a printhead maintenance station, said maintenance station comprising:

a capper sealingly engageable around said printhead, said capper comprising a constriction member for defining a blast channel adjacent an ink ejection face of said printhead;

a vacuum system in fluid communication with said capper;

an air inlet valve in fluid communication with said capper; and

an engagement mechanism for moving said capper between a first position in which said capper is sealingly engaged around said printhead and a second position in which said capper is disengaged from around said printhead;

(ii) moving said capper into said first position such that said constriction member is spaced apart from said face, thereby defining said blast channel;

(iii) generating a vacuum over said face using said vacuum system, thereby purging ink from printhead nozzles onto said face, said air inlet valve being closed for said purging; and

(iv) opening said air inlet valve, thereby blasting air through said blast channel and removing ink from said face,

wherein the step (iv) of blasting air through said blast channel is performed subsequent to the step (iii) of purging ink from said nozzles.

2. The method of claim **1** comprising the further step of:

(v) moving said capper into said second position.

3. The method of claim **2** comprising the further step of:

(vi) dabbing ink from around said printhead.

4. The method of claim **1**, wherein said capper comprises a perimeter gasket for sealing engagement around said printhead.

5. The method of claim **1**, wherein said vacuum system comprises a vacuum pump.

17

6. The method of claim 1, wherein said constriction member is spaced less than 0.5 mm from said face in said first position.

7. The method of claim 1, wherein said constriction member is substantially coextensive with said printhead.

8. The method of claim 1, wherein said vacuum system and said air inlet valve are arranged to control a direction of air flow through said blast channel.

9. The method of claim 8, wherein said printhead comprises a wire bond encapsulant along one edge, and said air flow buffets into said encapsulant.

10. The method of claim 8, wherein said air flows transversely across said face.

11. The method of claim 1, wherein said vacuum system further comprises a vacuum reservoir.

18

12. The method of claim 11, wherein said vacuum reservoir is charged prior to said purging.

13. The maintenance station of claim 11, wherein said vacuum reservoir is discharged during said air blasting.

14. The method of claim 1, wherein said vacuum system further comprises an ink dump for receiving ink removed from said face during said air blasting.

15. The method of claim 14, wherein said vacuum system directs said removed ink into said ink dump during air blasting.

16. The method of claim 1, wherein said printhead is a pagewidth inkjet printhead.

17. The method of claim 1, wherein step (iv) is performed about 50 to 500 ms subsequent to step (iii).

* * * * *