



US00D728104S

(12) **United States Design Patent**  
**Katchis et al.**

(10) **Patent No.:** **US D728,104 S**

(45) **Date of Patent:** **\*\* Apr. 28, 2015**

- (54) **BONE COMPRESSION STAPLE**
  - (71) Applicant: **Nextremity Solutions, Inc.**, Red Bank, NJ (US)
  - (72) Inventors: **Stuart D. Katchis**, Scarsdale, NY (US); **Lon S. Weiner**, Rumson, NJ (US); **John R. Pepper**, Cheshire, CT (US)
  - (73) Assignee: **Nextremity Solutions, Inc.**, Red Bank, NJ (US)
  - (\*\*) Term: **14 Years**
  - (21) Appl. No.: **29/462,902**
  - (22) Filed: **Aug. 9, 2013**
  - (51) **LOC (10) Cl.** ..... **24-02**
  - (52) **U.S. Cl.**  
USPC ..... **D24/155**
  - (58) **Field of Classification Search**  
USPC ..... D24/155, 156, 145; 606/75, 86 R, 248, 606/282, 293, 297; 623/11, 16, 17.11, 623/17.13, 19.11; D8/391-393, 367; 227/902
- See application file for complete search history.

- D587,370 S \* 2/2009 Coillard-Lavirotte et al. .... D24/155
- D596,294 S \* 7/2009 Coillard-Lavirotte et al. .... D24/155
- 8,518,089 B2 \* 8/2013 Gabele ..... 606/282
- D691,720 S \* 10/2013 Cheney et al. .... D24/145
- 2004/0127902 A1 \* 7/2004 Suzuki et al. .... 606/69
- 2010/0174328 A1 \* 7/2010 Seaton et al. .... 606/86 R
- 2014/0039561 A1 \* 2/2014 Weiner et al. .... 606/282

\* cited by examiner

*Primary Examiner* — Ian Simmons

*Assistant Examiner* — Charles Hanson

(74) *Attorney, Agent, or Firm* — Heslin Rothenberg Farley & Mesiti P.C.

(57) **CLAIM**

The ornamental design for the bone compression staple, as shown and described.

**DESCRIPTION**

FIG. 1 is a top perspective view of the bone compression staple comprising our new design; FIG. 2 is a bottom perspective view of the design of FIG. 1; FIG. 3 is a top plan view of the design of FIG. 1; FIG. 4 is a bottom plan view of the design of FIG. 1; FIG. 5 is a left side elevational view of the design of FIG. 1, where the right side elevational view is a mirror image; FIG. 6 is a back elevational view of the design of FIG. 1; and FIG. 7 is a front elevational view of the design of FIG. 1.

The broken lines immediately adjacent to the claimed areas represent the bounds of the claimed design while all other broken lines are directed to the environment and are for illustrative purposes only; the broken lines form no part of the claimed design.

**1 Claim, 3 Drawing Sheets**

(56) **References Cited**  
U.S. PATENT DOCUMENTS

- D281,814 S \* 12/1985 Pratt et al. .... D24/145
- 5,454,814 A \* 10/1995 Comte ..... 606/75
- D364,462 S \* 11/1995 Michelson ..... D24/145
- D378,409 S \* 3/1997 Michelson ..... D24/145
- 5,779,707 A \* 7/1998 Bertholet et al. .... 606/75
- 6,187,009 B1 \* 2/2001 Herzog et al. .... 606/75
- D586,915 S \* 2/2009 Grim ..... D24/145

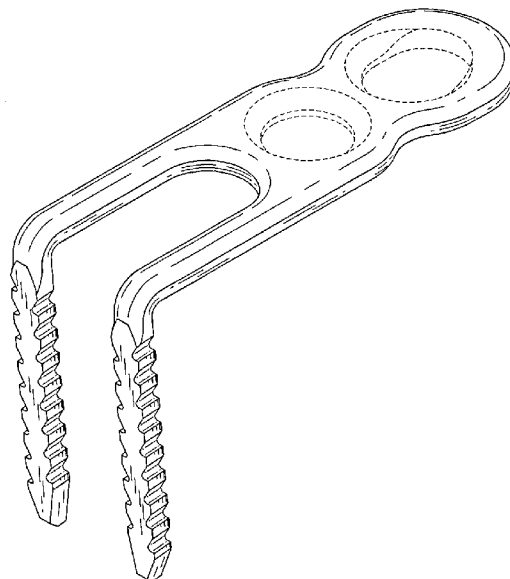

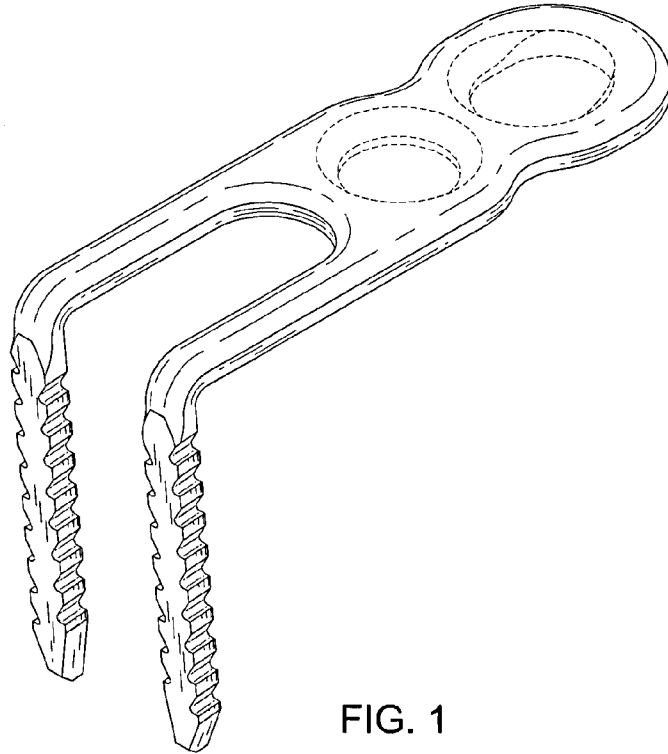

FIG. 1

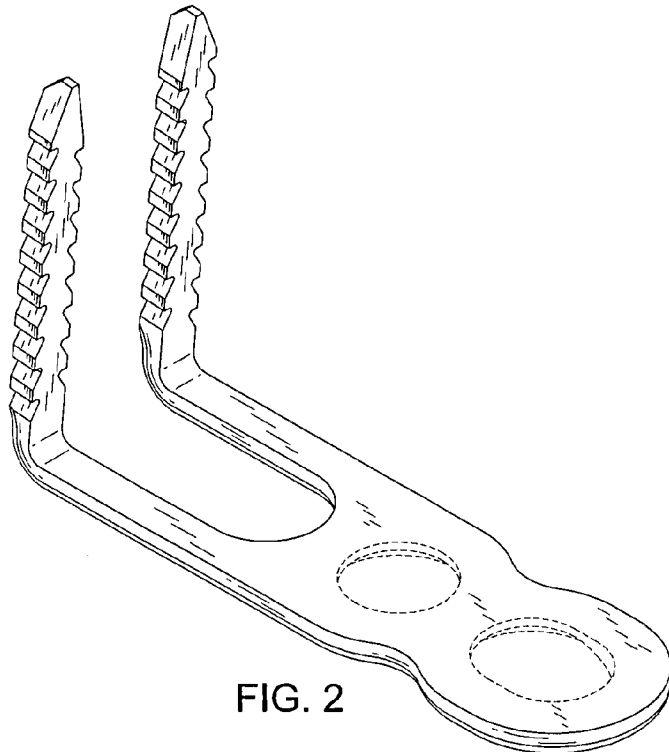

FIG. 2

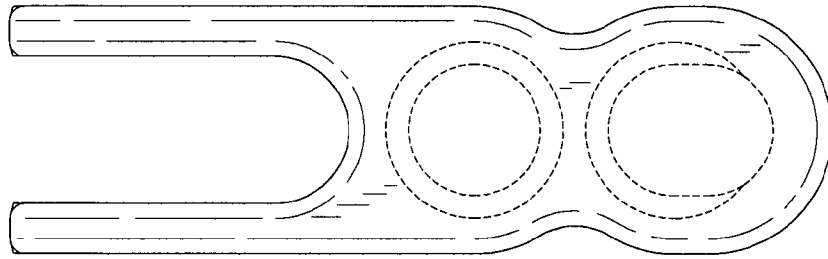

FIG. 3

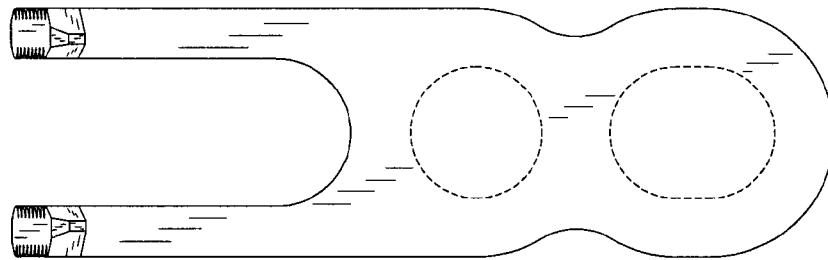

FIG. 4



FIG. 5

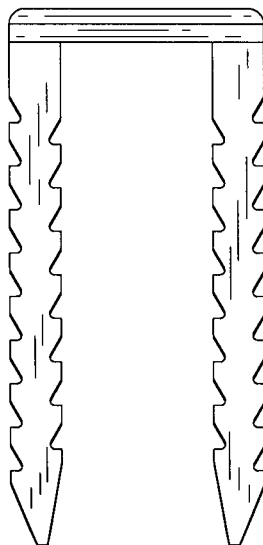

FIG. 6

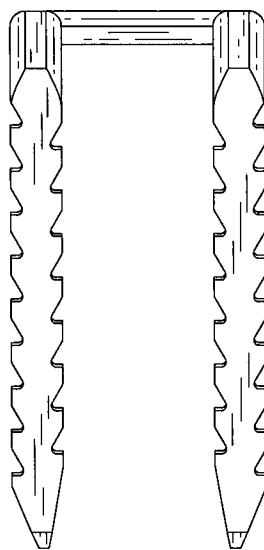

FIG. 7