

A. M. LOCKHART.
ENVELOP.

APPLICATION FILED OCT. 10, 1914.

1,166,772.

Patented Jan. 4, 1916.

2 SHEETS—SHEET 1.

Fig. 1.

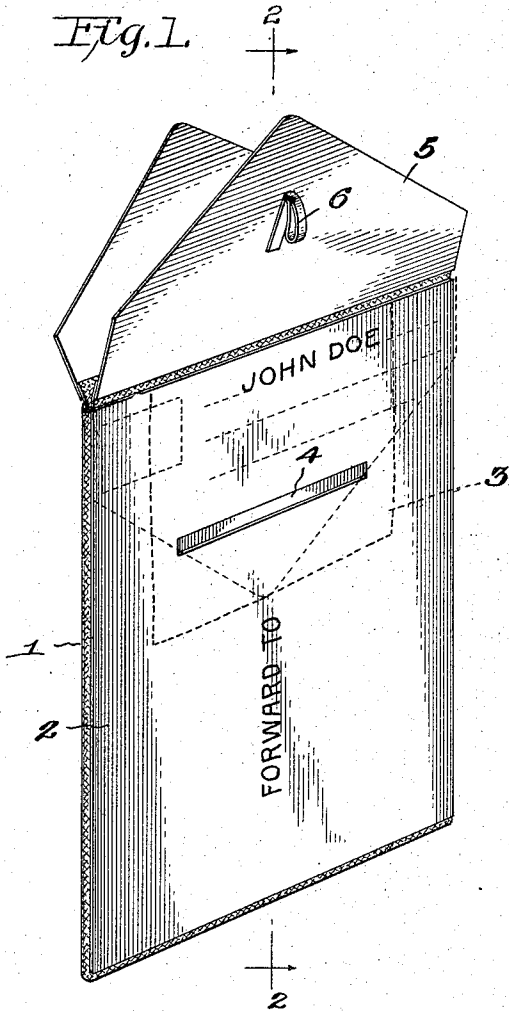
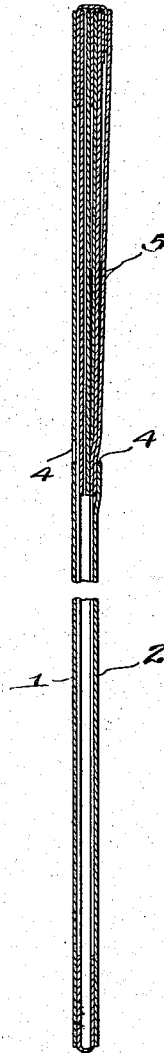

Fig. 2.



WITNESSES

J. H. Burgess

INVENTOR.

Alexander M. Lockhart

Max H. Sulboitz
ATTORNEY

A. M. LOCKHART.
ENVELOP.

APPLICATION FILED OCT. 10, 1914.

1,166,772.

Patented Jan. 4, 1916.

2 SHEETS—SHEET 2.

Fig. 3.

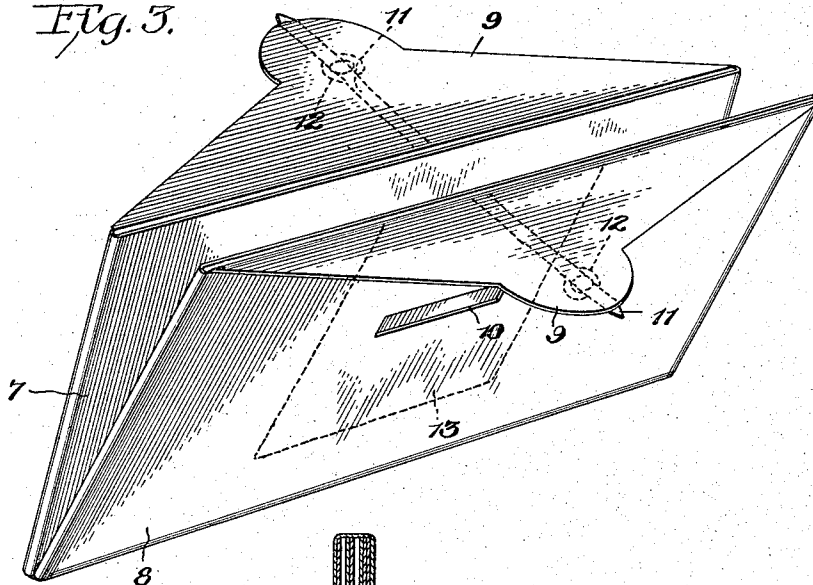
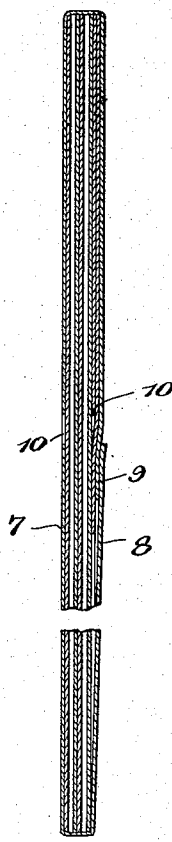

Fig. 4.



WITNESSES

J. A. Rogers

INVENTOR.

Alexander M. Lockhart

Max H. Sobush
ATTORNEY

UNITED STATES PATENT OFFICE.

ALEXANDER M. LOCKHART, OF PITTSBURGH, PENNSYLVANIA.

ENVELOP.

1,166,772.

Specification of Letters Patent.

Patented Jan. 4, 1916.

Application filed October 10, 1914. Serial No. 866,048.

To all whom it may concern:

Be it known that I, ALEXANDER M. LOCKHART, a citizen of the United States of America, residing at Pittsburgh, in the county of Allegheny and State of Pennsylvania, have invented certain new and useful Improvements in Envelops, of which the following is a specification, reference being had therein to the accompanying drawing.

This invention relates to envelops and has for its object to provide a device of such class, with means in a manner as hereinafter set forth, to enable the envelop to be used for sending and return, that is to say whereby the same envelop can be employed for forwarding purposes and for return purposes and to further provide an envelop with means to receive the forwarding address and return address, said means concealing the return address when the envelop is used for forwarding purposes and concealing the forwarding address when used for return purposes.

With the foregoing and other objects in view the invention consists of the novel construction, combination and arrangement of parts as hereinafter more specifically described and illustrated in the accompanying drawings wherein is shown an embodiment of the invention, but it is to be understood that changes, variations and modifications can be resorted to which come within the scope of the claim hereunto appended.

In the drawings wherein like reference characters denote corresponding parts throughout the several views:—Figure 1 is a perspective view of a device constructed in accordance with my invention; Fig. 2 is an enlarged section therethrough showing the envelop in sealed position; Fig. 3 is a perspective view of a slightly modified form of the invention; and Fig. 4 is an enlarged section therethrough showing the envelop sealed.

Referring to Figs. 1, 2, 3 of the drawings the envelop body is formed with two plies, of any suitable material, as indicated at 1, 2, and each of said plies is rectangular in contour and secured together at their longitudinal edges as well as at one end edge thereby forming a receptacle open at one end. The inner face of each of the plies 1, 2, has secured thereto a rectangular strip 3 of less width and length than the ply and which is flush with the free end edge of the ply. Each of the plies is formed

with a transverse slot 4, and which constitutes a mouth for the entrance of a pocket formed by the strip 3 in connection with the ply.

Projecting from each end edge of a ply is a triangular shaped flap 5, having secured to each side thereof a finger piece 6. The flaps 5 are of the same size and are adapted to be folded against the outer face of a ply and extended through a mouth 4 whereby the open end of the ply portion or receptacle is closed.

It will be noted that by fixing the strips 3 to the inner faces of the plies 1 and 2, it will provide suitable pockets for the ends of the flaps 5 when inserted through the slots 4 so that said flaps will not interfere with the contents of the envelop.

When using the envelop for forwarding purposes the outer face of one flap is provided with an address and the two flaps then folded to extend into a mouth 4. The other side of the body near the mouth 4 is also provided with an address.

If it be desired to use the envelop for return purposes the flaps are swung free of the mouth 4 formed in one ply and extend against the other face of the body portion and into the other mouth and which conceals the address. The outer face of the other flap is then provided with the address on the other side of the body portion.

By the foregoing arrangement of an envelop it is obvious that the flaps are utilized for two purposes, one to close the mouth of the envelop and the other for concealing and carrying an address.

The form of envelop shown in Figs. 3 and 4 is what is termed a compartment envelop and includes two receptacles 7, 8, which constitute the body portion of the envelop and said compartments are capable of being folded against each other. Associating with each of the compartments is a flap 9. One side of one compartment is provided with a transverse slot and the opposite side of the other compartment with a transverse slot. The slots are indicated at 10. Each of the flaps 9 is formed with a reinforcing strip 11 and a finger piece or loop 12. Each of the compartments opens at that end which is provided with a flap 9. When the two compartments are folded together one of the slots 10 is concealed and said slots 10 constitute mouth pieces which are formed by strips 13 secured to the inner

face of one wall of a compartment and which in connection with a wall provide a pocket. When the compartments are folded together, two flaps are extended into that slot 10 which is exposed, under such conditions the receptacles are closed. The flaps 9 are utilized in the same manner as the flaps 5, that is to say for concealing and carrying an address and for closing the mouth of the compartments.

What I claim is:—

An envelop of the class described comprising a body consisting of a front and rear wall secured together and open at one end to form an entrance opening therefor, said walls each having a transverse slit therein, strips secured to the inner faces of said walls and forming internal pockets thereon, said strips terminating at their one end in the

aforesaid slits whereby to provide entrance openings for said pockets, the opposite ends of said strips terminating flush with the end edges of said walls, a substantially triangular covering flap formed on the edge of each portion of the body at the open end thereof, said flaps being adapted to contain a forwarding and return address thereon and further adapted for folding together over the open end of the body to be received in one of said slits and form a closure for said body, and finger pieces carried on said flaps for the operation thereof.

In testimony whereof I affix my signature in the presence of two witnesses.

ALEXANDER M. LOCKHART.

Witnesses:

MAX H. SROLOVITZ,
MARIE H. ZBIERA.

Copies of this patent may be obtained for five cents each, by addressing the "Commissioner of Patents, Washington, D. C."