

(No Model.)

2 Sheets—Sheet 1.

W. BAINBRIDGE. ORE SEPARATOR.

No. 413,013.

Patented Oct. 15, 1889.

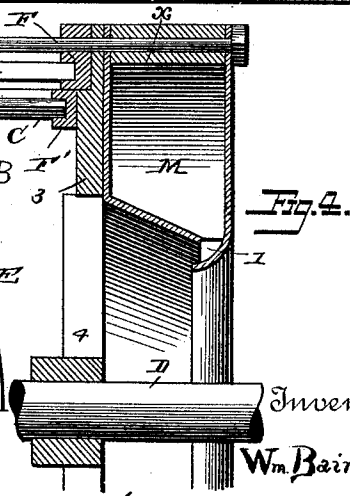
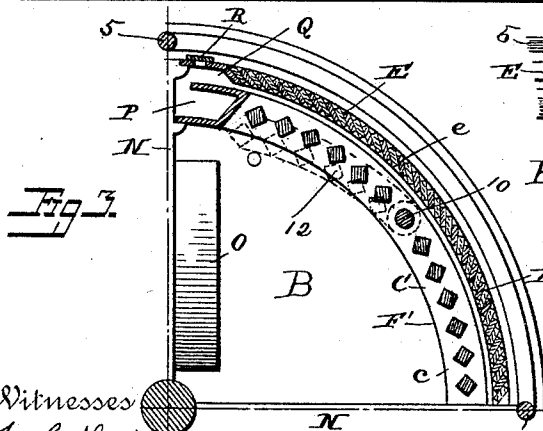
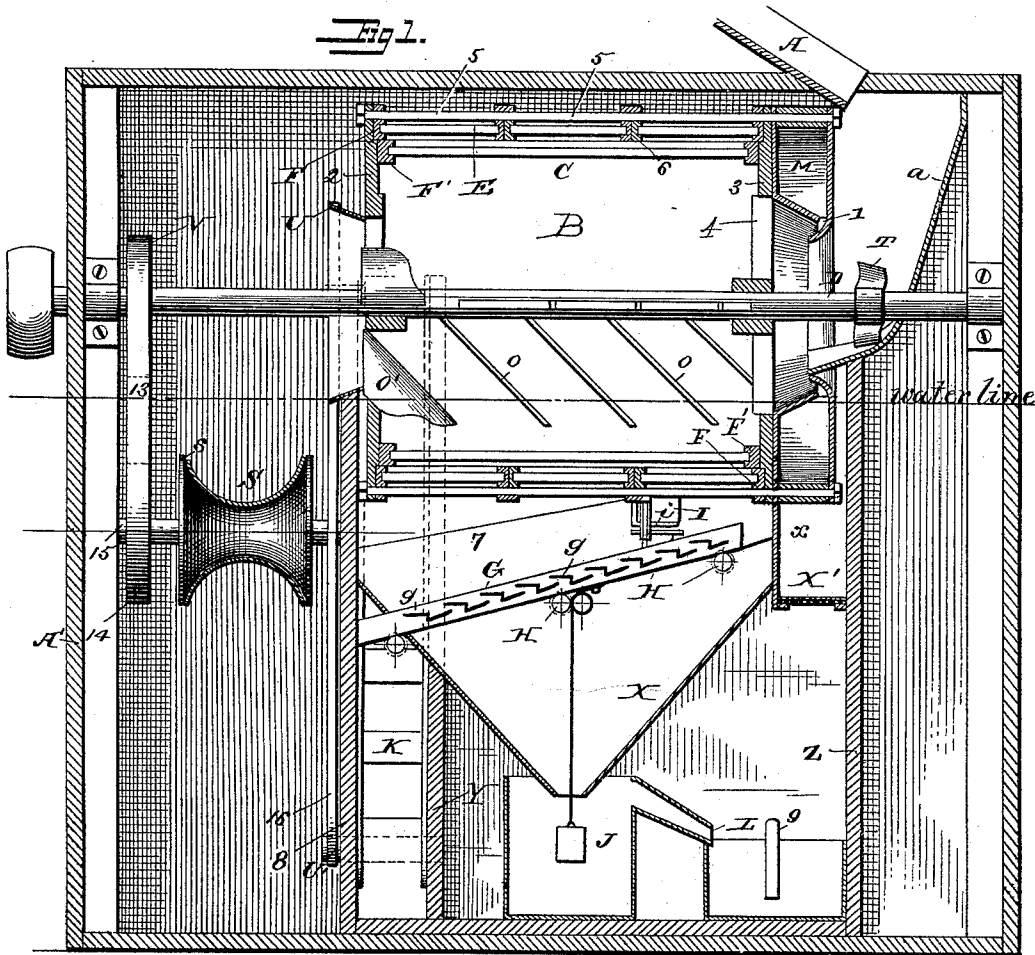

Witnesses
Prof. Stinkel Jr.
Jos. A. Blackwood

Inventor
 Wm. Bainbridge
 per *R. S. Durbin*
 Attorney

(No Model.)

2 Sheets—Sheet 2.

W. BAINBRIDGE. ORE SEPARATOR.

No. 413,013.

Patented Oct. 15, 1889.

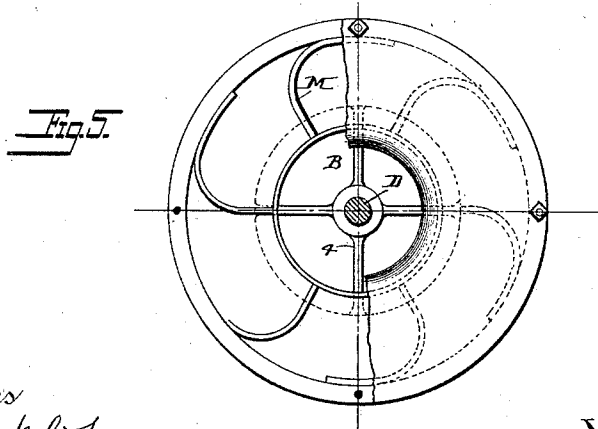
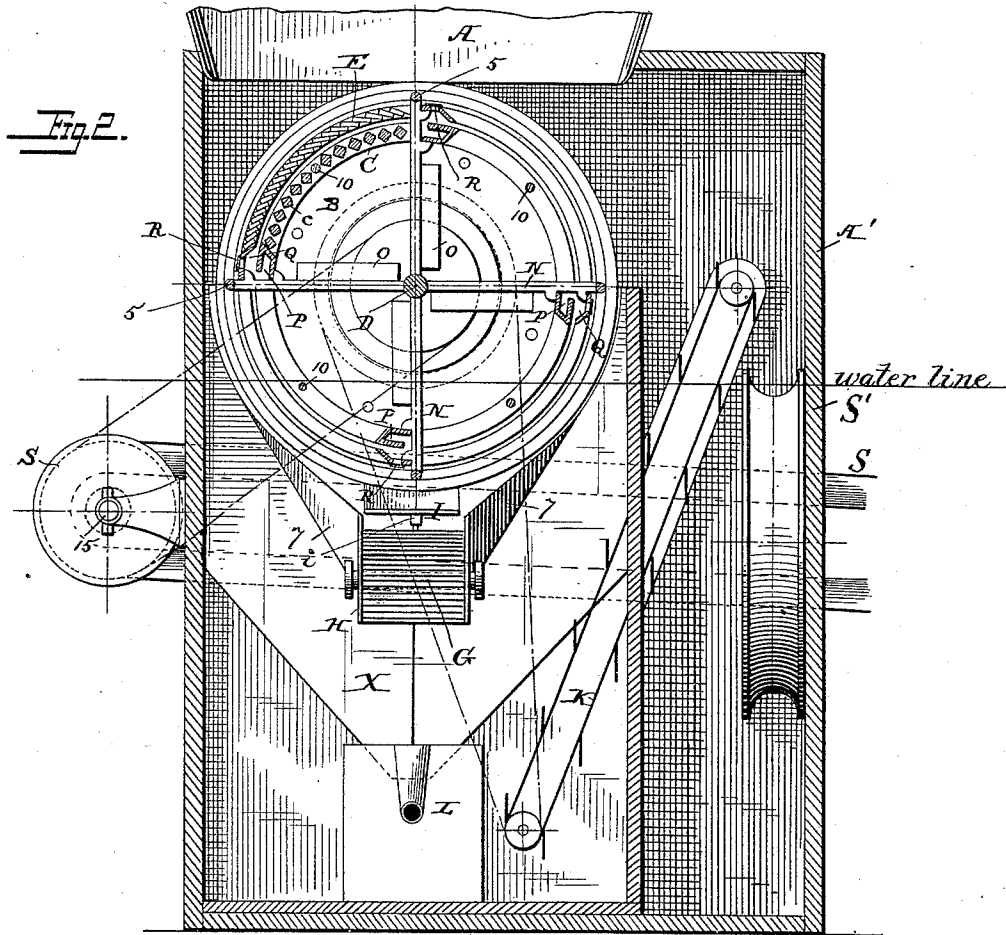

Witnesses
Jno. G. Hinkel Jr.
Josh. Blackwood

Inventor
Wm. Bainbridge.
 by *R. S. DuBois*
 Attorney

UNITED STATES PATENT OFFICE.

WILLIAM BAINBRIDGE, OF OMAHA, NEBRASKA.

ORE-SEPARATOR.

SPECIFICATION forming part of Letters Patent No. 413,013, dated October 15, 1889.

Application filed August 29, 1888. Serial No. 284,083. (No model.)

To all whom it may concern:

Be it known that I, WILLIAM BAINBRIDGE, a citizen of the United States, residing at Omaha, in the county of Douglas and State of Nebraska, have invented certain new and useful Improvements in Apparatus for Treating Ore; and I do hereby declare the following to be a full, clear, and exact description of the invention, such as will enable others skilled in the art to which it appertains to make and use the same.

My invention relates to an apparatus adapted to be worked in the presence of water to collect the particles of gold or other mineral from sand or gravel containing the same, it being particularly intended for treating low-grade ores containing but little mineral, from which it is adapted to collect the flour or float scale as well as the grain gold.

It consists of an apparatus to be hereinafter described, whereby such low-grade ores or sand and gravel may be advantageously and profitably washed and the precious metals concentrated and saved therefrom.

In the drawings, Figure 1 is a central longitudinal section. Fig. 2 is a transverse section looking toward the tail end of the cylinder, part of one of the cylinder-heads being broken away and the position of water-elevator being indicated in dotted lines. Fig. 3 is a transverse section, enlarged, of a portion of the cylinder. Fig. 4 is a horizontal section, enlarged, of a portion of the head end of the cylinder. Fig. 5 is a front end view, enlarged, of the cylinder, parts being broken away.

The material to be treated is fed into the casing A' inclosing the apparatus through a hopper A, which discharges upon an incline or chute *a*, by which it is directed into a cylindrical rotating screen B, mounted upon a central shaft D. This cylinder-screen is composed of the heads 2 3, supported from the shaft D by spiders 4, and connected with each other by longitudinal bars or stay-rods 5, extending lengthwise of the cylinder-screen.

Each cylinder-head supports interiorly two concentric rings F F', formed, preferably, of metal and grooved upon their inner faces to receive, respectively, the ends of the bars, which together make up the screening-sur-

faces of the cylinder-screen, represented, respectively, by C and E. The inner surface C is in the nature of a grate formed of longitudinal bars *c*, preferably of metal square in cross-section, and placed edge to edge, so as to leave narrow spaces between them, through which the screened material may pass to the outer screening-surface E, which is composed of slats or bars *e*, preferably of glass, supported by the rings F, and also by intermediate rings 6, carried by the longitudinal bars 5, if found necessary. The glass slats *e* overlap each other, as best seen in Fig. 3, and are arranged so that the spaces between them are less than the spaces between the bars *c*. The interior of the cylinder-screen is divided into several compartments, preferably four, by longitudinal partitions N, extending from head to head and from the shaft to the outer screening-surface E. Each partition has secured to one end of its faces inclined strips or flights O, which serve to feed through the machine such material as fails to pass through the surface C, the final strip O' at the tail end of the machine being scoop-shaped to facilitate the discharge of the material through the central opening of the head 2. Such fine material as passes outward through the outer screening-surface E and which contains the scale or flour gold or other mineral being collected falls upon the inclined wing-boards 7, by which it is directed to a shoe G, mounted in an inclined position upon rollers or equivalent supports H below the cylinder. This riffle is composed of a series of Z-shaped plates *g*, mounted in a frame so as to slightly overlap each other and leave open spaces between and under the sections or plates *g*. The angles or knees of the Z-shaped plates retain any grain gold which may find its way to the riffle. The float gold and fine lighter débris floats off into a hopper X, by which it is conveyed to a reservoir or settling-receptacle L, while the pyrites, black sand, and the like heavier materials pass to the discharge end of the riffle and are conveyed away by a conveyor K.

To facilitate the separation of the various kinds of material delivered upon the shoe, the latter is given a vibratory and preferably knocking or thumping motion. This I prefer

to impart by means of an inclined bearing strip or cam I, carried by the cylinder-screen and engaging with a projection *i* upon the riffle, which is thereby slid upon its supports toward the head of the machine. As soon as this cam disengages the projection *i* the riffle is returned by gravity, assisted by a weight J, until it is arrested with a jar by striking against the partition 8, situated opposite its discharge end. These jarring and reciprocating movements advance the materials upon the riffle and cause them to separate, as above set forth. The lighter portions of the sediment collected in the tank or reservoir L are withdrawn through a siphon 9, which leaves the heavier portions containing the gold or other mineral in the bottom of the tank, which, when sufficient has collected, is cleaned and the material removed treated in any suitable manner to collect the fine gold or other mineral contained therein.

The cylinder-screen B is provided at its head end with a series of curved elevator-blades M, of scoop shape, secured to the outer face of the head 3 and arranged to elevate the water from the tank and discharge it through the opening 1 into the cylinder through the central opening in the head 3, thus creating a constant circulation of water through the cylinder from the interior outward so long as it is rotated, such circulation carrying with it the fine particles of the mineral through the screening-surfaces C and E.

X' is a screen or filter consisting, preferably, of some porous or fibrous material mounted between perforated plates or wire-cloth and situated between the partitions *h* and *x*, below the elevator-blades M. This screen operates to prevent the passage of any float material which may be in suspension in the water while allowing the latter to flow readily through the same. A portion 12 of the grate-surface C, bounding each division formed by the partitions N, is hinged at 10, so that as the cylinder-screen revolves it automatically vibrates between the positions shown in full and dotted lines in Fig. 3, thus periodically opening communication between the interior of the cylinder-screen and the space between the gratings C and E, so that all material which has passed through the grate-surface C, but is too coarse to pass through the surface E, is returned through the opening made by the grate-surface 12, assuming the dotted-line position, into the interior of the cylinder-screen, to be passed out along with the other waste material at the tail end thereof. Each division of the cylinder-screen is provided with a trap P, arranged adjacent to one of the partitions N and opening into the space between the screening-surfaces C and E. Into these traps the particles of gold which are too large to pass between the glass strips forming the surface E collect, and from

which they may be removed at proper intervals through openings Q in the outer screen E, which openings are covered by slides R.

Opposite the discharge-opening through the tail and head 2 of the cylinder-screen is mounted a conveyer-belt S, running over a concave or centrally-grooved pulley *s*, mounted on the shaft 15, and receiving such material as is discharged from the cylinder B and delivering it out of the machine.

T are stirrer arms or blades arranged within the hopper or feeding-chute *a* and mounted upon the shaft D, by which they are rotated to stir and feed into the cylinder the material from the hopper A.

The cylinder-screen may be driven from any suitable motor, and the shaft 15, carrying the pulley *s*, may be belted to the shaft D of the cylinder by a belt 13, passing over pulleys 14 and V, carried by the said shafts, respectively.

The conveyer K is driven from the shaft D by a belt 16, passing over pulleys U U', carried, respectively, by the said shaft and the shaft of one of the turning wheels of the conveyer, and serves to raise the material passing from the shoe and to deposit it on the grooved wheel S', from which it drops on the conveyer-belt S, above referred to.

I will now describe the operation of the apparatus: The tank being sufficiently filled with water, the cylinder-screen is rotated and the material fed slowly into the machine from the hopper A. As it passes along the cylinder-screen it is thoroughly agitated by the rotation thereof and the action of the screening-surfaces C and E. The finest material, including the float and very small particles of gold, passes through the two screens C and E, being aided in such passage by the water which is being constantly poured into the cylinder by the elevator-blades M, and is directed by the wing-boards 7 to the riffle G. The agitation of the riffle, as hereinbefore described, serves to further separate the matter fed thereto, the finest portion (including the float gold) being carried off, and finally collecting in the reservoir L, the small particles or granules of gold being caught by the knees of the riffle-plates *g*, while the practically worthless matter is fed over the tail end of the riffle and is delivered to any suitable receptacle or place by the conveyer K. The larger particles of gold which, having passed between the bars of the grate C, yet fail to pass between the bars or slats of the screen E, are collected in the pockets P, whence from time to time they are removed together with such other material as may have collected therein. After the material between the screening-surfaces has been sufficiently subjected to their action, it comes opposite to the pivoted portion 12 of the inner grate or screen-surface, whereby such portion as has failed to pass through the screen E or to collect in the pockets P, and which is usually worthless

matter, is returned into the interior of the cylinder, to be passed therefrom and out of the machine by the conveyer S.

Having thus described the most approved form of my invention now known to me, and without limiting myself to the precise construction and arrangement of the parts as shown and described, I claim—

1. In an ore-separator, a shoe composed of a frame, and Z-shaped plates mounted therein and arranged with spaces between them, forming horizontal shelves and settling-pockets for the gold, substantially as described.

2. An ore-separating screen divided longitudinally by partitions provided with flights or advancing plates carried by the partitions, substantially as described.

3. In an ore-separator, a cylinder having concentric screening-surfaces, the outer one being the finer, the pockets P, communicating with the space between the screening-surfaces, and the openings into the pockets through the outer surface closed by slides, substantially as described.

4. In combination with a rotary screen provided with an oblique cam, an inclined shoe mounted on rollers beneath the screen and having a projection to engage the oblique cam, substantially as described.

5. In an ore-separator, a screen composed

of two cylindrical surfaces, the inner being made up of angular metallic bars placed edge to edge with spaces between, and the outer consisting of flat slats of very hard material overlapping each other with small spaces between, substantially as described.

6. In an ore-separator, a screen composed of two surfaces, the inner coarser than the outer and having a portion of its cylinder hinged to swing open into the central space, substantially as described.

7. In an ore-separator, a rotating screen divided longitudinally into compartments provided with two concentric screening-surfaces, the outer finer than the inner, and the inner provided with swinging traps opening into the interior, substantially as described.

8. In an ore-separator, a rotating screen composed of two screening-surfaces, the outer finer than the inner, longitudinal partitions, traps in the inner surface opening into the interior, and pockets between the surfaces and next the partitions, arranged substantially as described.

In testimony whereof I affix my signature in presence of two witnesses.

WILLIAM BAINBRIDGE.

Witnesses:

CHARLES E. STRATTON,
ROBERT A. CODDING.