

Jan. 10, 1967

M. DANEMARK ETAL
ELECTROPLATING INSTALLATION

3,297,380

Filed July 10, 1963

3 Sheets-Sheet 1

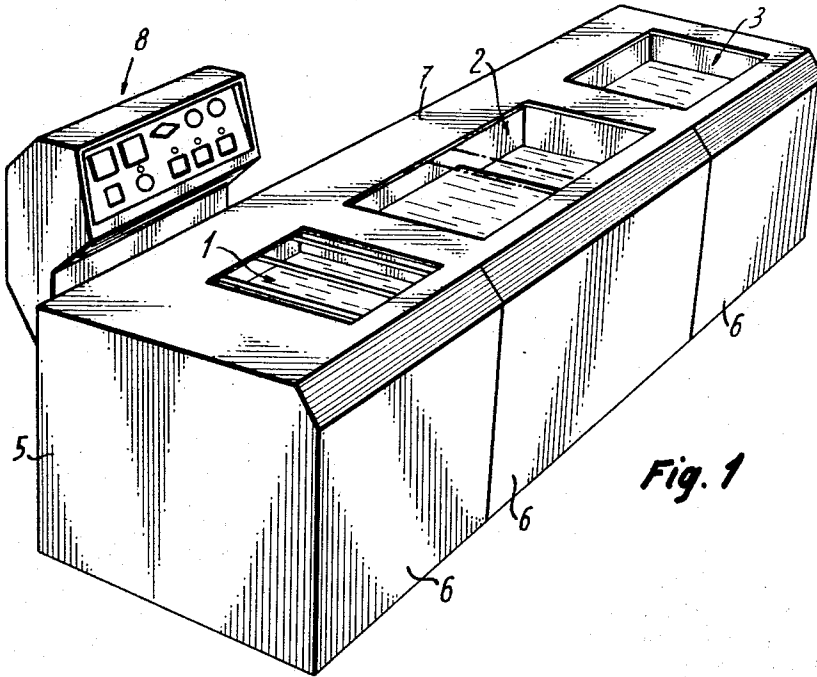

Fig. 1

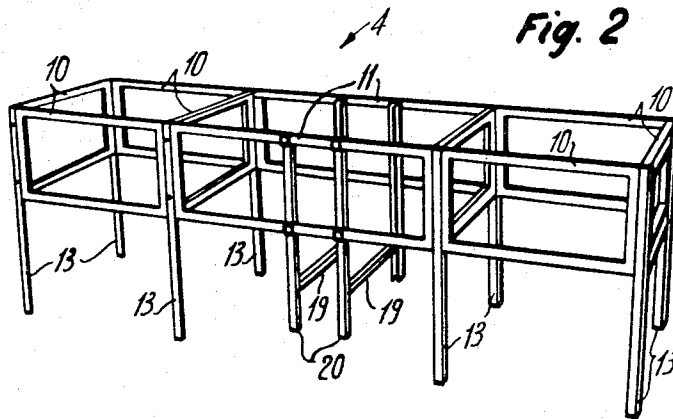

Fig. 2

INVENTORS
MARIUS DANEMARK
RENE ROCHAT
CHARLES STEINER
WILLIAM ZWERNER

BY

Dreene and Durr

Jan. 10, 1967

M. DANEMARK ETAL
ELECTROPLATING INSTALLATION

3,297,380

Filed July 10, 1963

3 Sheets-Sheet 2

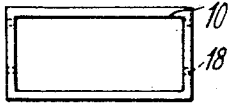

Fig. 3

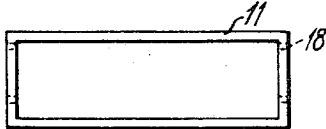

Fig. 4

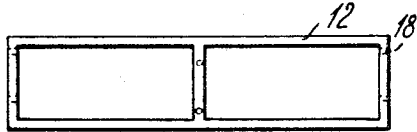

Fig. 5

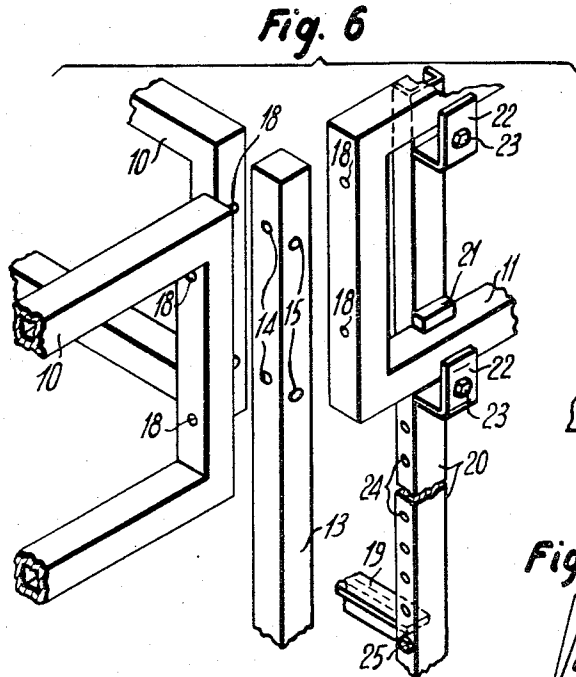

Fig. 6

Fig. 8

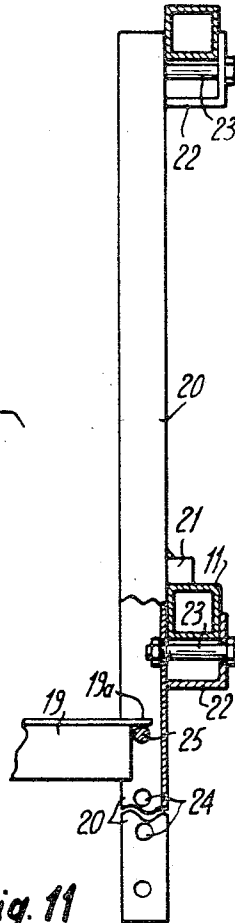
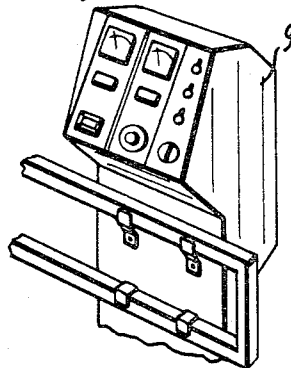
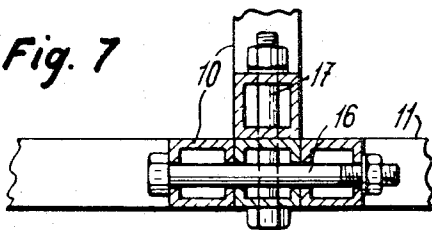

Fig. 11

Fig. 7



INVENTORS
MARIUS DANEMARK
RENE ROCHAT
CHARLES STEINER
WILLIAM ZWERNER

BY

Greene and Dunn

Jan. 10, 1967

M. DANEMARK ETAL
ELECTROPLATING INSTALLATION

3,297,380

Filed July 10, 1963

3 Sheets-Sheet 3

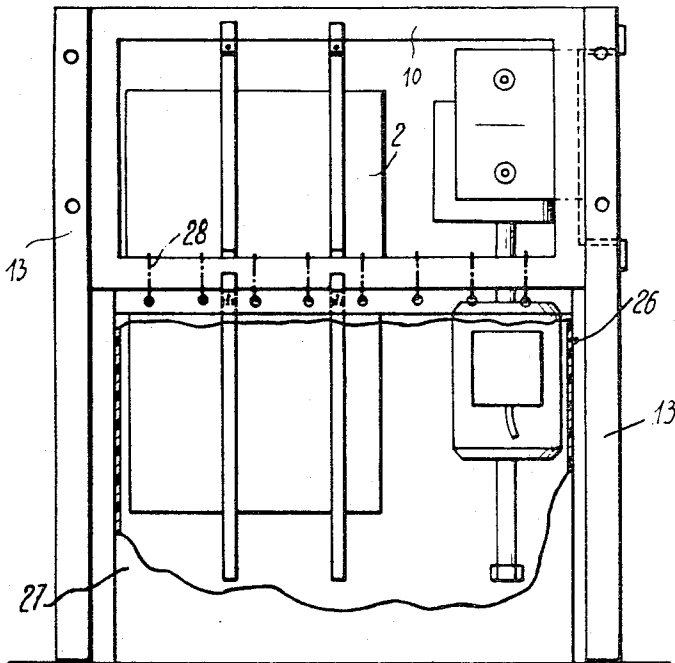

Fig. 9

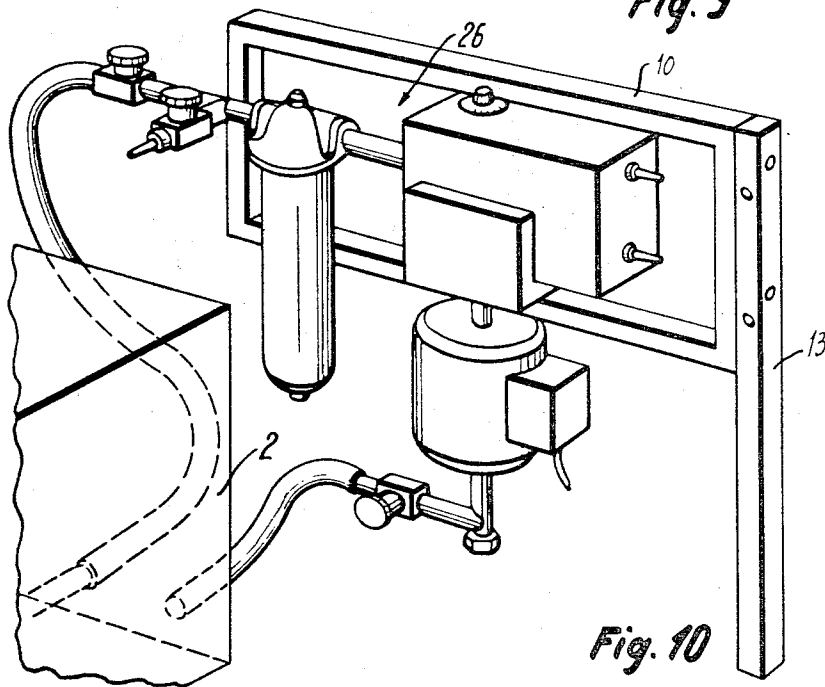

Fig. 10

INVENTORS
MARIUS DANEMARK
RENE ROCHAT
CHARLES STEINER
WILLIAM ZWERNER

BY

Greene and Shaver

1

3,297,380

ELECTROPLATING INSTALLATION

Marius Danemark and Rene Rochat, Geneva, Charles Steiner, Vernier, and William Zwerner, Geneva, Switzerland, assignors to Sel-Rex Corporation, Nutley, N.J., a corporation of New Jersey

Filed July 10, 1963, Ser. No. 294,060

2 Claims. (Cl. 312—228)

The object of the present invention is an installation for electroplating including a structure especially designed for the support of tanks containing baths.

The disadvantage of the electroplating installations on the market at the present time is that they cannot be transformed and adapted to changes in location, or to new conditions in connection with their use. Consideration has been given to dividing electroplating installations into unit elements or blocks designed to be placed side by side. However, since certain of these installations had to be, because of their condition of employment, longer than the unit block, without interruption, provision had to be made for blocks longer than the unit. As a result, these installations have not been very adaptable to transformations. The user desiring to change a unit block for a block of longer length, would often have a surplus of unused blocks. Moreover, the juxtaposition of the blocks, in imitation of certain kitchen installations, is not very satisfactory.

The aim of the present invention is to provide an installation easily manufactured on a mass-production basis, in order to keep the cost down, while being at the same time very adaptable in its use. In other words, this invention will permit the construction of "custom-made" installations with standardized materials.

The installation, according to the invention, is characterized by the fact that the structure is transformable and, for that purpose, is constituted of transversed and longitudinal elements assembled together in such a way as to be demountable, with the longitudinal elements, at least, presenting lengths with the function of a module so that, depending on what longitudinal elements are selected, a variety of structures adapted to required use and available space, may be obtained.

The drawing shows, by way of an example, a form of execution of the object of the invention.

FIGURE 1 is a view, in perspective, of an electroplating installation.

FIGURE 2 is a schematic view, in perspective, of a structure which is part of the installation, on a small scale.

FIGURES 3, 4, and 5 are elevations on a small scale of three of the elements of the structure.

FIGURE 6 is an exploded perspective view of elements of the structure on a larger scale, illustrating how they are assembled.

FIGURE 7 is a cross sectional view of part of the assembled elements.

FIGURE 8 is an elevation of a detail, shown partially in cross section.

FIGURE 9 is an elevational view showing part of the installation and the elements thereof.

FIGURE 10 is a schematic view, in perspective, of the part of the installation shown in FIG. 9.

FIGURE 11 is a perspective view of another detail.

The above installation or assemblage comprises tanks 1, 2 and 3 for electroplating, supported by a structure 4 as shown in FIG. 2. This structure is covered by a cabinet with end panels 5, longitudinal side panels 6, and a top cover 7 in which openings for the tanks are provided.

Accessories such as cabinet 8 (FIG. 1) in which is enclosed the electrical controls of the installation, and a panel control, are affixed to the back side of the structure 4. A variation 9 of such a cabinet, is shown in FIG. 11

2

together with a portion of the frame which is unobscured by said panels 5 and 6.

Structure 4 comprises transverse and longitudinal elements each made up of frames which are disposed vertically. These frames shown in detail in FIGS. 3, 4 and 5 are respectively numbered 10, 11 and 12. Note that their lengths have the function of a module, the unit of which is the length of frame 10 plus the space necessary to separate two consecutive frames, so that by selecting different frames, structures of various dimensions may be achieved. The length of frame 10 is equal, by definition, to the module less said space separating the two frames; the length of frame 11 is equal to $1\frac{1}{2}$ times the module less said space, and that of frame 12 is twice the module less said space.

For example, if the space separating the two frames were 30 mm. and the module 730 mm., frame 10 would be 700 mm. long, frame 11 1065 mm. long and frame 12, 1430 mm. long.

In the example shown, the transverse frames of structure 4 are constituted by frames 10, but in another case, these transverse elements may be made with frames 11, for instance.

The different frames composing structure 4 are supported by legs 13, each made of simple bars of a square section, the side of which is equal to the space mentioned above by which two consecutive frames are separated. Two pairs of holes, 14 and 15, are drilled through these legs 13 to receive screws 16 or 17 (FIGS. 6 and 7). These pairs of holes are placed at various heights and are perpendicular to each other. They are thus placed so that one or the other, depending on the way frames 10 to 12 are employed, will correspond to a pair of holes 18 provided on each of the small sides of these frames.

The structure described can, in this way, be quickly set up and its dimensions can easily be adapted to fit the particular requirements of the user. Composed of a very limited number of different elements, this structure is simply and quickly put together and consequently its cost is modest.

The apparatus included in the installation, particularly the tanks, rest on transverse rods 19 affixed at adjustable heights to columns 20 which are hooked to the inside of the frames 10, 11 or 12. The mounting of these transverse rods 19 and of the columns 20 is visible in detail in FIGS. 6 and 8; the columns 20, formed of U-shaped iron bars, have stops 21 which support said columns 20 from the lower bar of frames 10, 11 or 12, the columns 20 being held in place by L-shaped pieces 22, affixed by screws to the lower and upper bars of said frames. Holes are provided in columns 20 to receive bolts 25 forming brackets for the transverse rods 19. These rods 19 are shown as T-shaped, and have their ends cut at 19a so that they may rest on the brackets 25. As shown in FIGS. 2 and 9, columns 20 do not extend down as far as legs 13 but are supported from said frame members 11. The transverse rods 19 may be secured by other means or have other cross sectional shapes within the limits of the present invention.

In addition, the installation may be provided with longitudinal rods supported from columns 20, suspended from the transverse frames to support the tanks instead of said transverse rods 19.

Please note that besides being flexible in its use, the present invention has the advantage of not having transverse partitions as are necessary in the case of juxtaposition of complete units which are complete in themselves, thus allowing a longitudinal passage for different elements of the installation, particularly for hydraulic plumbing, electrical conduits and air-suction conduits, for example. This permits an assemblage such as assemblage 26 of FIGURES 9 and 10 to be placed in any part of the struc-

3

ture or to be placed at some distance from the tanks; this assemblage 26 can house, for instance, heating units, refrigeration, filtration units, pumps, etc.

Lastly, it must be pointed out that one or more of the tanks may be partially enclosed in protective liquid-proof, chemically resistant containers such as plastic bags, plastic vessels, plastic lined bags or containers, etc. as shown by the line 27 in FIG. 9, partially broken away. Said containers may rest on the ground and be held at the upper part by hooks 28 attached to the lower bars of the frames 10, 11, or 12. These protective containers prevent losses of bath liquids and consequently of the valuable metals or other chemicals contained therein, which occur through overflow or leakage of the tanks. Such protective bags are easily placed or removed, being placed around the tanks and around the means 19, 20 for holding said tanks.

In a variation, frames 10 and 12 constituting the element of the structure may be replaced by different elements without departing from the spirit of the invention, its essence residing, as indicated in the claims, in the fact that these structures are transformable and constituted by longitudinal elements the lengths of which take on the function of a module. It is from this characteristic that the main advantages of the invention originate, for it insures a standardization of manufacture.

We claim:

1. In a device for supporting a series of treating means including at least two liquid-containing tanks and especially useful in electroplating installations comprising at least seven rectangularly shaped frame members comprising a first series of at least three of the same size and at least a second and third series made up of matching pairs of said frame members, at least three pairs of legs, each of said legs having, at least in the upper portion thereof, a substantially uniform, rectangular cross-sectional area defining opposed pairs of planar side portions,

4

each of said frame members having planar outer surfaces at opposite ends thereof of a width which is substantially equal to the width of one of the planar side portions of said legs whereby surface to surface contact between the ends of at least two frame members and the planar side portions of a leg may be obtained,

means connecting the first series of frames transversely between said three pairs of legs with the planes of the rectangularly shaped frame members being vertical,

means connecting said second and third pairs of frame members between adjacent pairs of legs, tank-supporting means suspended from the inside of at least two adjacent parallel frames for supporting a liquid-holding tank therebetween.

2. The device as claimed in claim 1 comprising at least one tank positioned on said tank-supporting means and a liquid-proof, chemically-resistant container extending around the lower portion of said tank, said container having its upper rim supported from at least two opposed frame members.

References Cited by the Examiner

UNITED STATES PATENTS

1,076,116	10/1913	Hatfield	312—111
2,297,614	9/1942	Fuchs	34—231
3,087,458	4/1963	Bennett	119—17
3,092,077	6/1963	Smoker	119—52

FOREIGN PATENTS

26,019	1907	Great Britain.
335,045	10/1930	Great Britain.
577,449	3/1958	Italy.
304,346	3/1955	Switzerland.

CHANCELLOR E. HARRIS, *Primary Examiner.*