

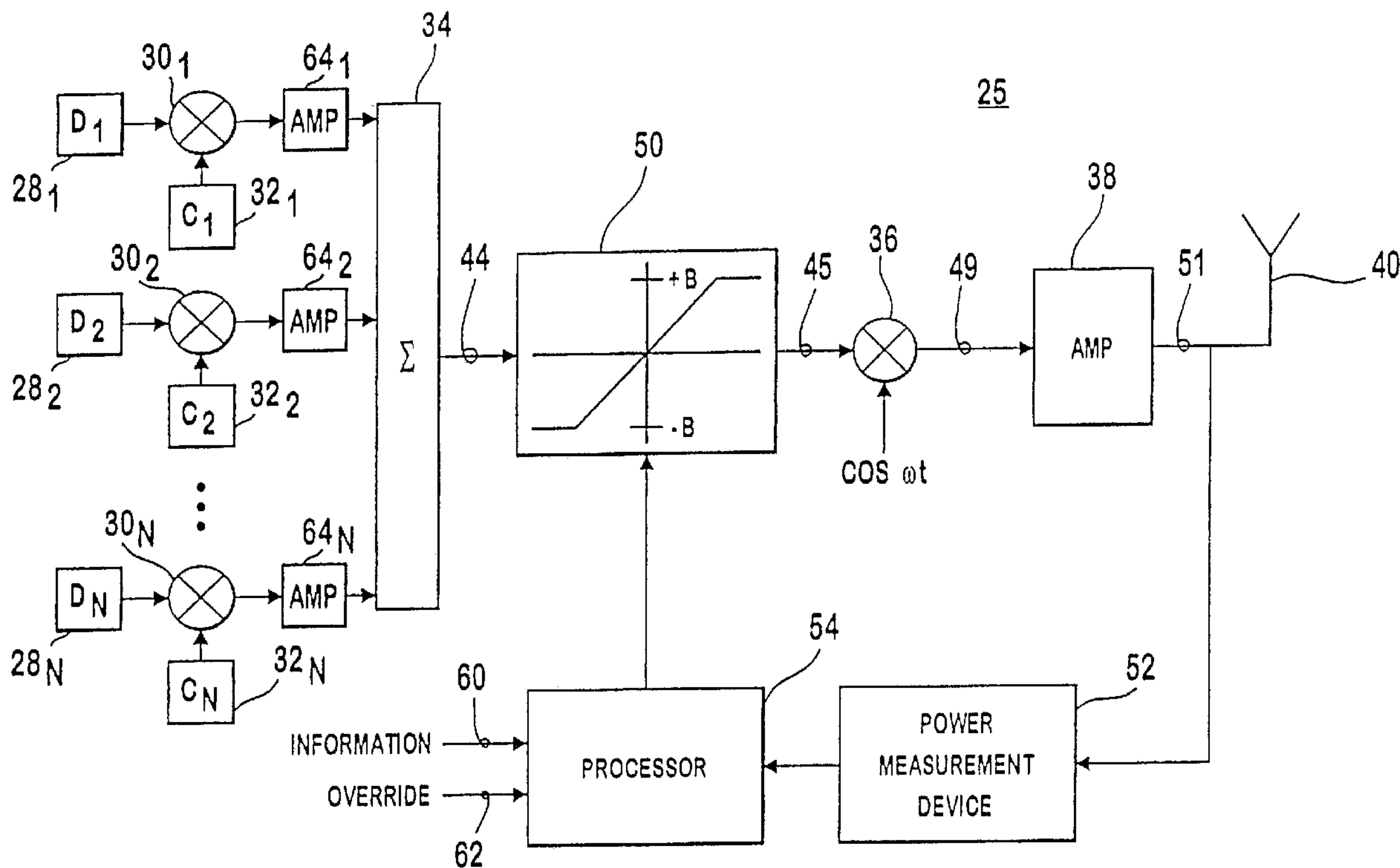

(22) Date de dépôt/Filing Date: 2000/08/23
 (41) Mise à la disp. pub./Open to Public Insp.: 2001/03/08
 (45) Date de délivrance/Issue Date: 2014/07/15
 (62) Demande originale/Original Application: 2 564 147
 (30) Priorité/Priority: 1999/08/31 (US09/386,876)

(51) Cl.Int./Int.Cl. *H04W 88/08* (2009.01)
 (72) Inventeurs/Inventors:
 KIERNAN, BRIAN, US;
 OZLUTURK, FATIH M., US
 (73) Propriétaire/Owner:
 INTERDIGITAL TECHNOLOGY CORPORATION, US
 (74) Agent: RIDOUT & MAYBEE LLP

(54) Titre : PRELIMITEUR ADAPTATIF D'AMPLIFICATEUR HF
 (54) Title: ADAPTIVE RF AMPLIFIER PRELIMITER



(57) Abrégé/Abstract:

The invention reduces transient peaks in signals transmitted in CDMA communication systems. A plurality of spread spectrum data signals are combined into a combined signal having fluctuating power level corresponding to the combination of the data signals. The combined signal is modulated to produce an RF signal for transmission. The average power of the combined signal is measured over a selected time period. The combined signal power level is adaptively limited to a calculated power level based at least in part on the measured power.

ABSTRACT

The invention reduces transient peaks in signals transmitted in CDMA communication systems. A plurality of spread spectrum data signals are combined into a combined signal having fluctuating power level corresponding to the combination of the data signals. The combined signal is modulated to produce an RF signal for transmission. The average power of the combined signal is measured over a selected time period. The combined signal power level is adaptively limited to a calculated power level based at least in part on the measured power.

TITLE OF THE INVENTION**ADAPTIVE RF AMPLIFIER PRELIMITER****BACKGROUND OF THE INVENTION**

This application is a divisional of Canadian patent application Serial No. 2,564,147, which in turn is a divisional of Canadian patent application Serial No. 2,451,976, which in turn is a divisional of Canadian patent application Serial No. 2,382,024 filed internationally on August 23, 2000 and entered nationally on February 14, 2002.

FIELD OF THE INVENTION

This invention generally relates to spread spectrum code division multiple access (CDMA) communication systems. More particularly, the present invention relates to a system and method for adaptively limiting forward and reverse link transmission power within CDMA communication systems.

DESCRIPTION OF THE PRIOR ART

Wireless communication systems using spread spectrum modulation techniques represent the state of the art in digital communications and are increasing in popularity. In code division multiple access (CDMA) systems, data is transmitted using a wide bandwidth (spread spectrum) by modulating the data with a pseudo random chip code sequence. The advantage gained is that CDMA systems are more resistant to signal distortion and interfering frequencies in the transmission channel than communication systems using other multiple access techniques such as time division multiple access (TDMA) or frequency division multiple access (FDMA).

One indicator used to measure the performance of a communication system is the signal-to-noise ratio (SNR). At the receiver, the magnitude of the desired received signal is compared to the magnitude of the received noise. The data within a

transmitted signal received with a high SNR is readily recovered at the receiver. A low SNR leads to loss of data.

A prior art CDMA communication system is shown in **Figure 1**. The communication system has a plurality of base stations $20_1, 20_2 \dots 20_N$ connected together through a local Public Switched Telephone Network (PSTN) exchange. Each base station $20_1, 20_2 \dots 20_N$ communicates using spread spectrum CDMA with mobile and fixed subscriber units $22_1, 22_2 \dots 22_N$ within its cellular area.

Shown in **Figure 2** is a simplified CDMA transmitter **24** and receiver **26**. A data signal having a given bandwidth is mixed with a spreading code generated by a pseudo random chip code sequence generator producing a digital spread spectrum signal for transmission. Upon reception, the data is reproduced after correlation with the same pseudo random chip code sequence used to transmit the data. By using different pseudo random chip code sequences, many data signals or subchannels can share the same channel bandwidth. In particular, a base station 20_1 can communicate with a group of subscriber units $22_1, 22_2 \dots 22_N$ using the same bandwidth. Forward link communications are from the base station 20_1 to the subscriber unit $22_1, 22_2 \dots 22_N$, and reverse link communications are from the subscriber unit $22_1, 22_2 \dots 22_N$ to the base station 20_1 .

For timing synchronization with a receiver **26**, an unmodulated pilot signal is used. The pilot signal allows respective receivers **26** to synchronize with a given transmitter **24**, allowing despreading of a traffic signal at the receiver **26**. In a typical CDMA system, each base station $20_1, 20_2 \dots 20_N$ sends a unique global pilot signal received by all subscriber units $22_1, 22_2 \dots 22_N$ within communicating range to synchronize forward link transmissions. Conversely, in some CDMA systems for example in the B-CDMAJ air interface each subscriber unit $22_1, 22_2 \dots 22_N$ transmits a unique assigned pilot signal to synchronize reverse link transmissions.

Figure 3 is an example of a prior art transmitter **24**. Data signals $28_1, 28_2 \dots 28_N$ including traffic, pilot and maintenance signals are spread using respective mixers $30_1, 30_2 \dots 30_N$ with unique chip code sequences $32_1, 32_2 \dots 32_N$, respectively. Each mixers' output is coupled to a combiner **34** which adds the individual mixed signals as a combined signal **44**. The combined signal **44** is modulated up to radio

frequency (RF) by a mixer **36** mixing the combined signal **44** with an RF carrier, shown in **Figure 3** as $\text{COS } \omega t$. The modulated signal is amplified to a predetermined transmission power level (TLP) by an amplifier **38** and radiated by an antenna **40**.

Most CDMA systems use some form of adaptive power control. In a CDMA system, many signals share the same bandwidth. When a subscriber unit **22₁, 22₂ ... 22_N** or base station **20₁, 20₂ ... 20_N** is receiving a specific signal, all the other signals within the same bandwidth are noise like in relation to the specific signal. Increasing the power level of one signal degrades all other signals within the same bandwidth. However, reducing TLP too far results in undesirable SNRs at the receivers **26**. To maintain a desired SNR at the minimum transmission power level, adaptive power control is used.

Typically, a transmitter **24** will send a signal to a particular receiver **26**. Upon reception, the SNR is determined. The determined SNR is compared to a desired SNR. Based on the comparison, a signal is sent in the reverse link to the transmitter **24**, either increasing or decreasing transmit power. This is known as forward channel power control. Conversely, power control from the subscriber unit **22**, to the base station **20**, is known as reverse channel power control.

Amplifiers **64₁, 64₂ ... 64_n** are used for adaptive power control in **Figure 3**. The amplifiers **64₁, 64₂ ... 64_n** are coupled to the inputs of the combiner **34** to individually control each signal's power level.

Figure 4a, 4b, 4c and 4d show a simplified illustration of three spread spectrum signals **42₁, 42₂, 42₃** and a resultant combined signal **44**. Although each signal **42₁, 42₂, 42₃** is spread with a different pseudo random chip code sequence, each signal **42₁, 42₂, 42₃** is synchronous at the chipping rate. When the individual chips within the sequences are summed, the combined signal may have extreme transients **46, 48** where the chip energies combine or low transients **47** where they subtract.

High transient peaks are undesirable. For every 3 dB peak increase, twice the base amplification power in Watts is required. Not only does the transient burden the amplifier, but the power sourcing the amplifier must have a capacity greater than the maximum transient that may be expected. This is particularly undesirable in hand-held battery operated devices. Additionally, to design for higher power levels resulting

from high transients, more complex amplifier circuitry is required or compromises between amplifier gain, battery life and communication time result. High valued transients force the amplifier **38** into the nonlinear region of its dynamic range resulting in increased out-of-band emissions and reduced amplifier efficiency. Accordingly, there exists a need for an adaptive RF transmitter system that addresses the problems associated with the prior art.

SUMMARY OF THE INVENTION

The invention reduces transient peaks in signals transmitted in CDMA communication systems. A plurality of spread spectrum data signals are combined into a combined signal having fluctuating power level corresponding to the combination of the data signals. The combined signal is modulated to produce an RF signal for transmission. The average power of the combined signal is measured over a selected time period. The combined signal power level is adaptively limited to a calculated power level based at least in part on the measured power.

Accordingly, the invention herein comprises a user equipment (UE) for transmitting signals employing a CDMA technique, comprising: means for combining a plurality of spread spectrum data signals; means for measuring a characteristic of the output of said combining means for a given time period; and means for adaptively limiting an output of the combining means responsive at least partially to an output of said measuring means.

The invention herein also comprises a method for operating a user equipment (UE) employing a CDMA technique, the method comprising: combining a plurality of spread spectrum data signals into a combined signal having a fluctuating power level corresponding to the data signals; modulating the combined signal to produce an RF signal; measuring average power of the combined signal over a selected time period; adaptively limiting the power of the combined signal power to a calculated level based at least in part on the measured average power; and transmitting the RF signal.

Moreover, the invention comprises a method for operating a user

equipment (UE) employing a CDMA technique, the method comprising: combining a plurality of spread spectrum data signals into a combined signal having a fluctuating power level corresponding to the data signals; modulating the combined signal to produce an RF signal; measuring the power of the combined signal over a selected time period; adaptively limiting the power of the combined signal power to a selected level based at least in part on the measured average power; and transmitting the RF signal.

According to an embodiment of the present disclosure there is provided a base station comprising: a plurality of mixers configured to mix a plurality of data signals with different code sequences; a combiner configured to combine the plurality of mixed data signals to produce a combined signal; an adjustable signal limiter configured to produce a limited signal wherein the adjustable signal limiter is coupled to the output of the combiner; a mixer configured to modulate the limited signal up to radio frequency (RF); a power measurement device configured to measure a power of the modulated limited signal over a predetermined time period; a processor configured to determine a clipping level of the adjustable signal limiter based on the measured power of the modulated limited signal; an amplifier configured to amplify the modulated limited signal to a predetermined power level to produce an amplified signal; and an antenna configured to transmit the amplified signal.

BRIEF DESCRIPTION OF THE DRAWINGS

Figure 1 is an illustration of a prior art CDMA system.

Figure 2 is an illustration of a prior art CDMA transmitter and receiver.

Figure 3 is a system block diagram of a prior art transmitter.

Figure 4a is an illustration of a first pseudo random chip code sequence.

Figure 4b is an illustration of a second pseudo random chip code sequence.

Figure 4c is an illustration of a third pseudo random chip code sequence.

Figure 4d is an illustration of the combined chip code sequences of **Figures 4a - 4c**.

Figure 5 is a system block diagram of an embodiment of the invention with the power measurement device coupled to the amplifier.

Figure 6 is a system block diagram of an alternate embodiment of the invention with the power measurement device coupled to the modulator.

Figure 7 is an illustration of the probability distribution function of the power levels of a combined signal.

Figure 8 is a plot of the loss in the received signal to noise ratio versus the clipping level.

Figure 9 is a plot of the loss in the received signal to noise ratio versus the clipping level in a CDMA communication system using adaptive power control.

Figure 10 is a system block diagram of an alternate embodiment of the invention

with the processor controlling the amplifier gain.

DESCRIPTION OF THE PREFERRED EMBODIMENTS

The preferred embodiments will be described with reference to the drawing figures where like numerals represent like elements throughout.

Figures 5 and 6 depict transmitter systems of the invention. A group of data signals **28₁, 28₂ ... 28_N** that include traffic, pilot and maintenance signals are mixed with different chip code sequences **32₁, 32₂ ... 32_N** and are summed together in a combiner **34** as a combined signal **44**. The combiner **34** is coupled to an adjustable signal limiter **50** (clipper) where signal power levels are hard limited to **+ββ** and **-ββ** dB. Power levels in between **+ββ** and **-ββ** are not affected. The limited signal **45** is modulated up to RF by a mixer **36**. The modulated signal is amplified by an amplifier **38** to a predetermined power level and radiated by antenna **40**.

Figure 7 illustrates a typical probability distribution function of the combined signal power level. A combined chip **46, 47, 48** as shown in **Figure 4d** will have an associated power level. The probability of a given combined chip having a particular power level is shown in **Figure 7**. The two extreme power levels are **+K** and **-K**. As shown in **Figure 7**, the probability of a given combined chip having a power level of **+K** or **-K** is extremely low. Whereas, the probability of a combined chip having a power level in the middle of the two extremes is high. Since a spread spectrum signal is spread across a wide communication bandwidth and there is a low probability that a combined chip will have a power level at the ends of the distribution, the combined signal **44** can be clipped below these extremes with insignificant loss.

The transmitter system adjusts the clipping levels, **ββ**, to eliminate the signal transients with only a small decrease in the transmittal signal-to-noise ratio (SNR). **Figure 8** is a graph illustrating the relationship between SNR and clipping levels for a system not using adaptive power control. The solid line, dash line and dotted line depict communication channels with different operating SNRs. As shown in **Figure 8**, for a **ββ** set at a clipping level of two standard deviations the loss in SNR is negligible and at a

clipping level of one standard deviation the loss is only approximately 0.2 dB.

For a system using adaptive power control, **Figure 9** is a graph of SNR versus the clipping level. The results are similar to those obtained in a system not using adaptive power control. As shown in **Figure 9**, with a clipping level of two standard deviations, the loss in SNR is again negligible. Accordingly, the clipping circuitry is applicable to systems utilizing adaptive power control and systems not using adaptive power control.

Referring back to **Figure 5**, to determine $\beta\beta$, the invention uses a power measurement device **52** and a processor **54**. The power measurement device **52** is coupled to either the output of the RF amplifier **38** as shown in **Figure 5** or the mixer **36** as shown in **Figure 6**. Preferably, the power measurement device **52** determines the average of the square of the magnitude of the transmitted signal over a predetermined time period. The output of the preferred power measurement device **52** approximates the variance of the mixed signal **49** or the signal **51** being transmitted. Alternatively, the power measurement device **52** determines an approximation of the standard deviation by taking the average of the absolute value of the signal **49**, **51** or the power measurement device **52** measures the magnitude of the signal **49**, **51** with the processor determining either the variance or standard deviation.

The output of the power measurement device **52** is coupled to a processor **54**. If the power measurement device **52** is coupled to the output of the amplifier **38**, the processor **54** scales down the output of the power measurement device **52** by the gain of the amplifier **38**. The processor **54** determines the proper clipping level for $\beta\beta$. Depending on the desired SNR and bandwidth, the value for $\beta\beta$ will be a multiple of the standard deviation. If the power measurement device **52** approximates the variance, the processor **54** will take the square root of the device's output as the standard deviation. In the preferred embodiment, $\beta\beta$ will be two times the standard deviation.

In certain situations, the processor **54** overrides the determined value of $\beta\beta$. For instance, if the transmitter **25** was used in a base station **20₁**, **20₂** ... **20_N**, a large increase in the number of users may result in $\beta\beta$ being temporarily set too low. This will result in an undesirable received SNR. As supplied to the processor **54** through the line **60**, the number of users currently in communication with the base station **20₁**, **20₂** ...

20_N , is used to either change $\beta\beta$ or temporarily disable the clipper **50** to allow all signals to pass unaltered when appropriate.

Additionally, since the probability distribution function assumes a large sample size, a small number of users may result in an undesired received SNR. Accordingly, if only a few users were in communication with the base station 20_1 , 20_2 ... 20_N , the clipper **50** may be disabled. In addition, when there are only a small number of users active, the amplifier's dynamic range is not reached. Accordingly, there is no need to clip the combined signal. Under other situations, it may be necessary to override the clipper **50**. For instance, in some CDMA systems short codes are used during initial power ramp up. Since these codes are not long enough to approximate a random signal, by chance one code may result in a large number of high transient peaks within the signal. Clipping these transmissions may dramatically decrease the received SNR and unnecessarily delay the initial power ramp up procedure. In these situations, a signal will be sent to the processor **54** through the line **62** to override the clipper **50**.

In an alternative embodiment shown in **Figure 10**, the processor **54** is also used to control the gain of the amplifier **38** through the line **58**. Stored in the processor is the amplifier gain characteristic. The amplifier gain is adjusted to keep the amplifier from going into the nonlinear operating region. Accordingly, out-of-band emissions and interference to services in adjoining frequency bands is reduced.

Although the invention has been described in part by making detailed reference to certain specific embodiments, such detail is intended to be instructive rather than restrictive. It will be appreciated by those skilled in the art that many variations may be made in the structure and mode of operation without departing from the scope of the invention as disclosed in the teachings herein.

WHAT IS CLAIMED IS:

1. A base station comprising:
 - a plurality of mixers configured to mix a plurality of data signals with different code sequences;
 - a combiner configured to combine the plurality of mixed data signals to produce a combined signal;
 - an adjustable signal limiter configured to produce a limited signal wherein the adjustable signal limiter is coupled to the output of the combiner;
 - a mixer configured to modulate the limited signal up to radio frequency (RF);
 - a power measurement device configured to measure a power of the modulated limited signal over a predetermined time period;
 - a processor configured to determine a clipping level of the adjustable signal limiter based on the measured power of the modulated limited signal;
 - an amplifier configured to amplify the modulated limited signal to a predetermined power level to produce an amplified signal; and
 - an antenna configured to transmit the amplified signal.

2. The base station according to claim 1 wherein the plurality of data signals includes any one of: traffic signals, pilot signals, or maintenance signals.

3. The base station according to claim 1 wherein the adjustable signal limiter limits signal power levels.

4. The base station according to claim 1 wherein:
 - the power measurement device is configured to determine an average of a square of a magnitude of the amplified signal over the predetermined time period.

5. The base station according to claim 4 wherein:
 - the power measurement device is coupled to the output of the amplifier and is configured to measure a power of the amplified signal; and
 - the processor is configured to determine the clipping level of the adjustable signal limiter based on the measured power of the amplified signal.
6. The base station according to claim 5 wherein the processor scales down the output of the power measurement device by a gain of the amplifier.
7. The base station according to claim 1 wherein an output of the power measurement device approximates a variance of the modulated limited signal.
8. The base station according to claim 1 wherein an output of the power measurement device approximates a variance of the amplified signal.
9. The base station according to claim 1 wherein:
 - the power measurement device is configured to approximate a variance of the amplified signal over the predetermined time period; and
 - the processor is configured to determine a square root of the amplified signal as a standard deviation.
10. The base station according to claim 9 wherein the standard deviation is two times a clipping level of the adjustable signal limiter.
11. The base station according to claim 1 wherein the processor is configured to override a determined clipping level of the adjustable signal limiter.

12. The base station according to claim 1 wherein the processor is configured to control a gain of the amplifier.

13. The base station according to claim 12 wherein the gain of the amplifier is adjusted to prevent the amplifier from going into a nonlinear operating region.

FIG. 1
PRIOR ART

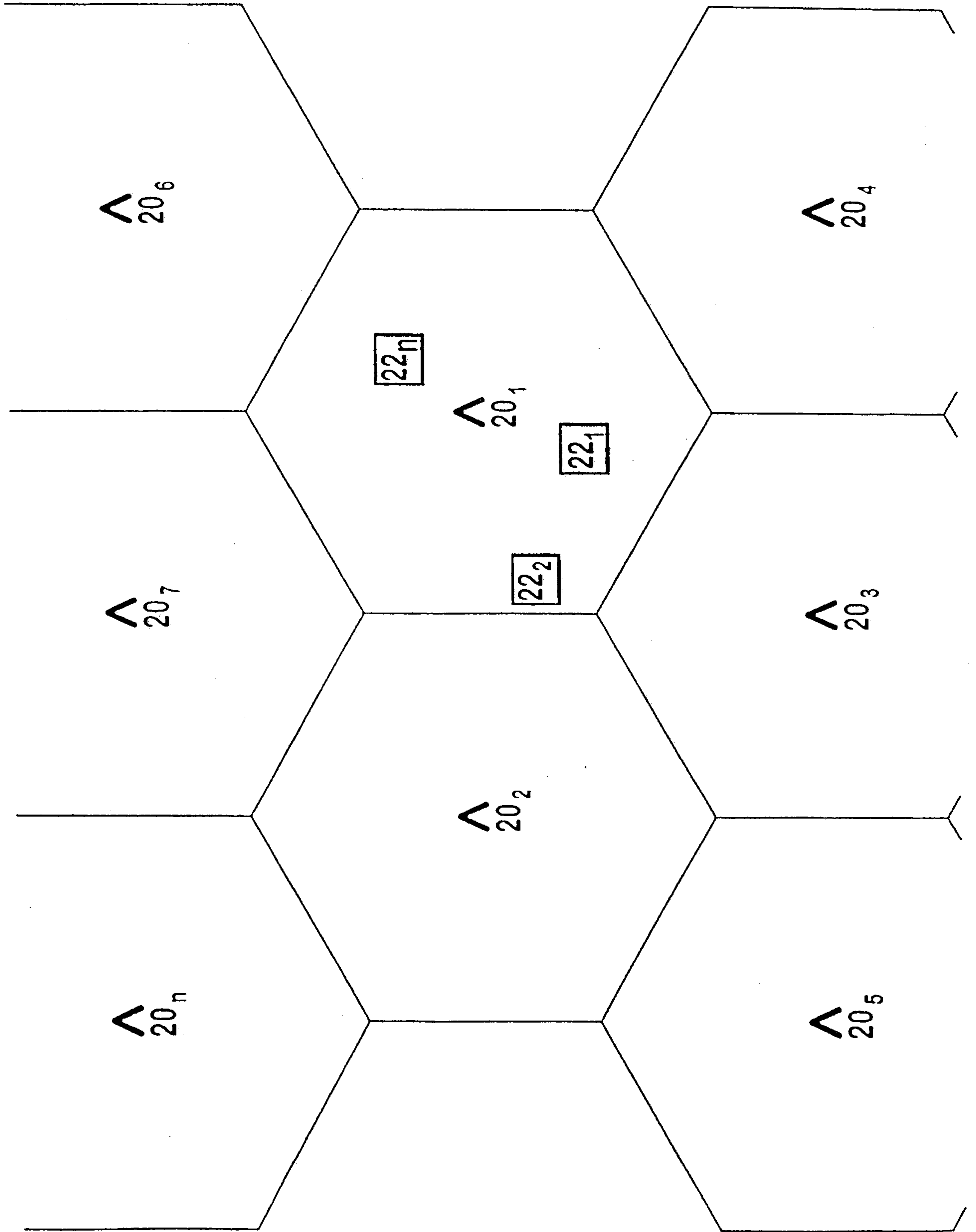

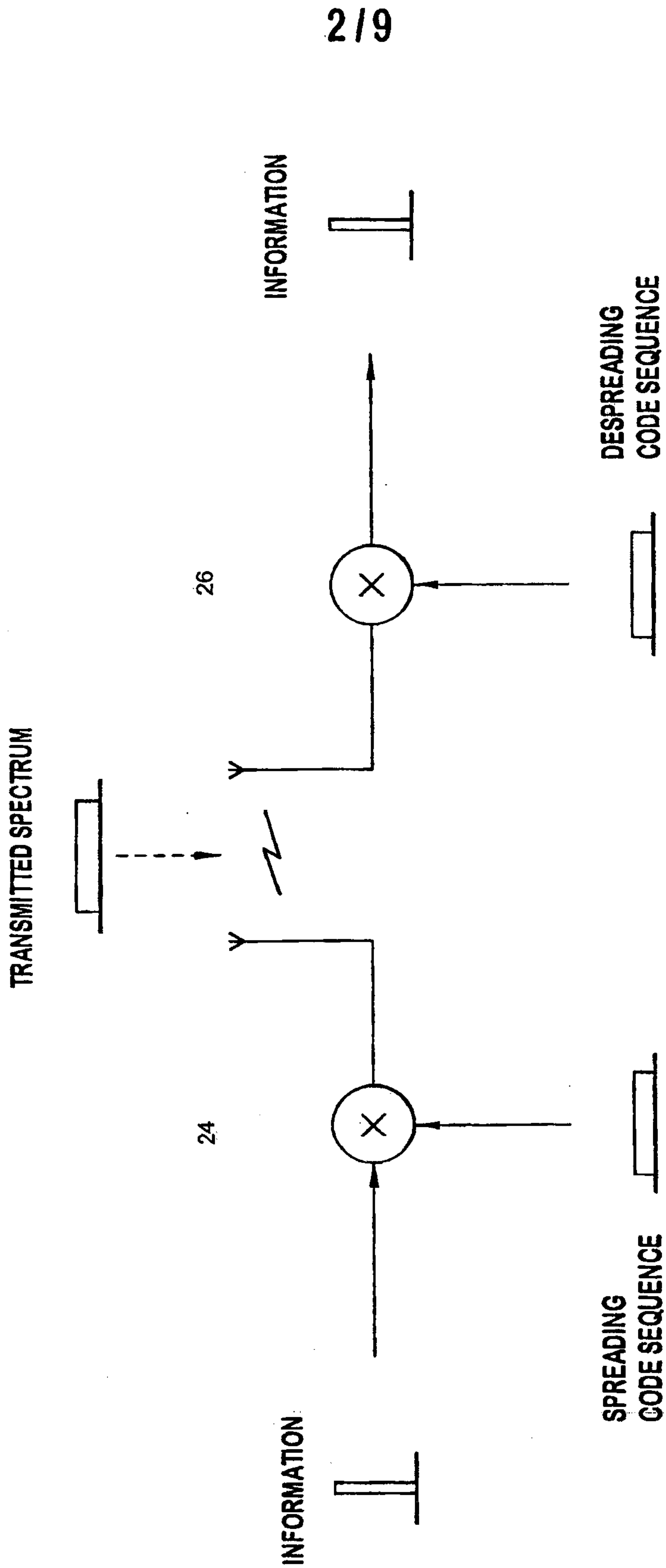

FIG. 2
PRIOR ART

24

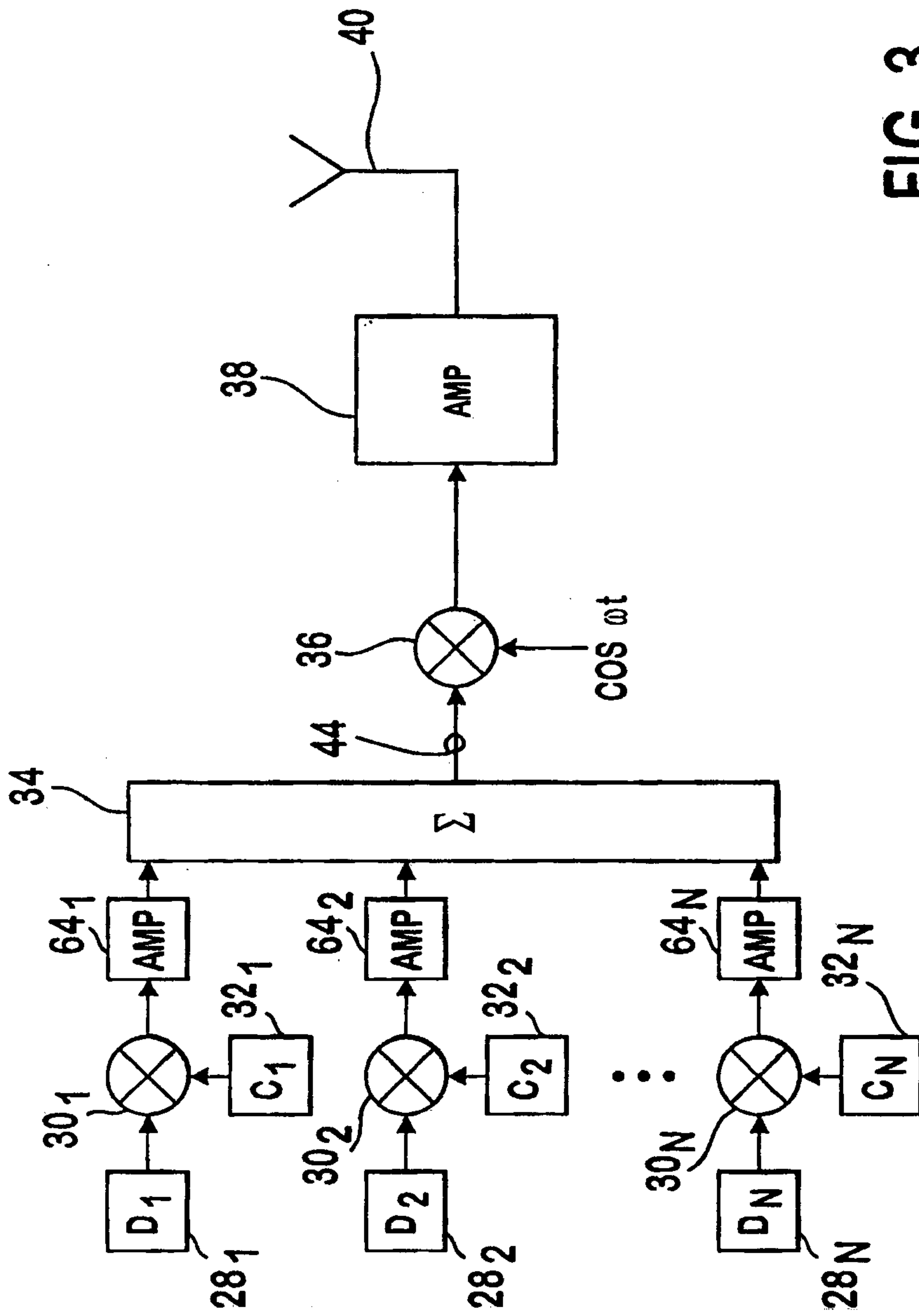

FIG. 3
PRIOR ART

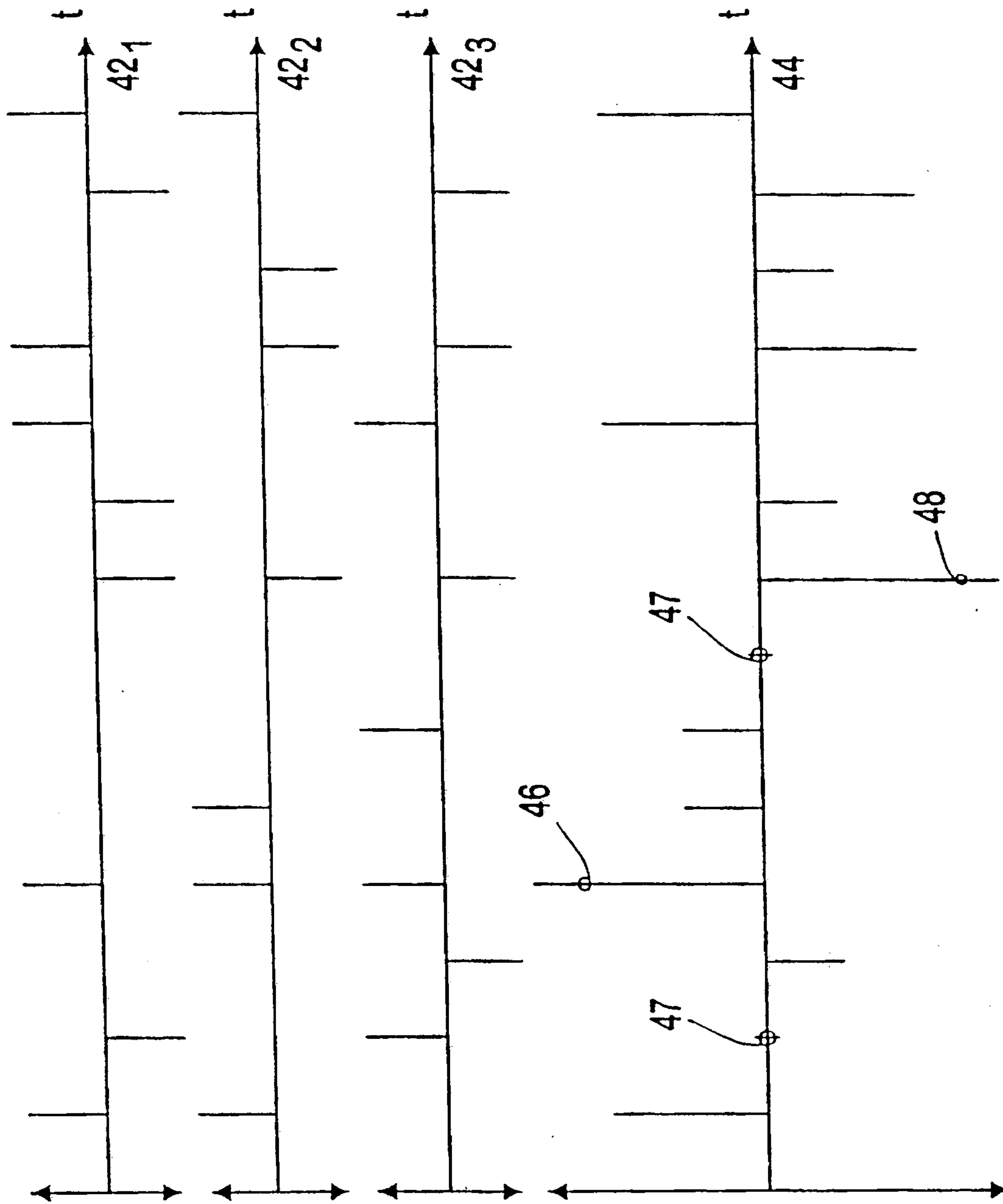

FIG. 4a

FIG. 4b

FIG. 4c

FIG. 4d

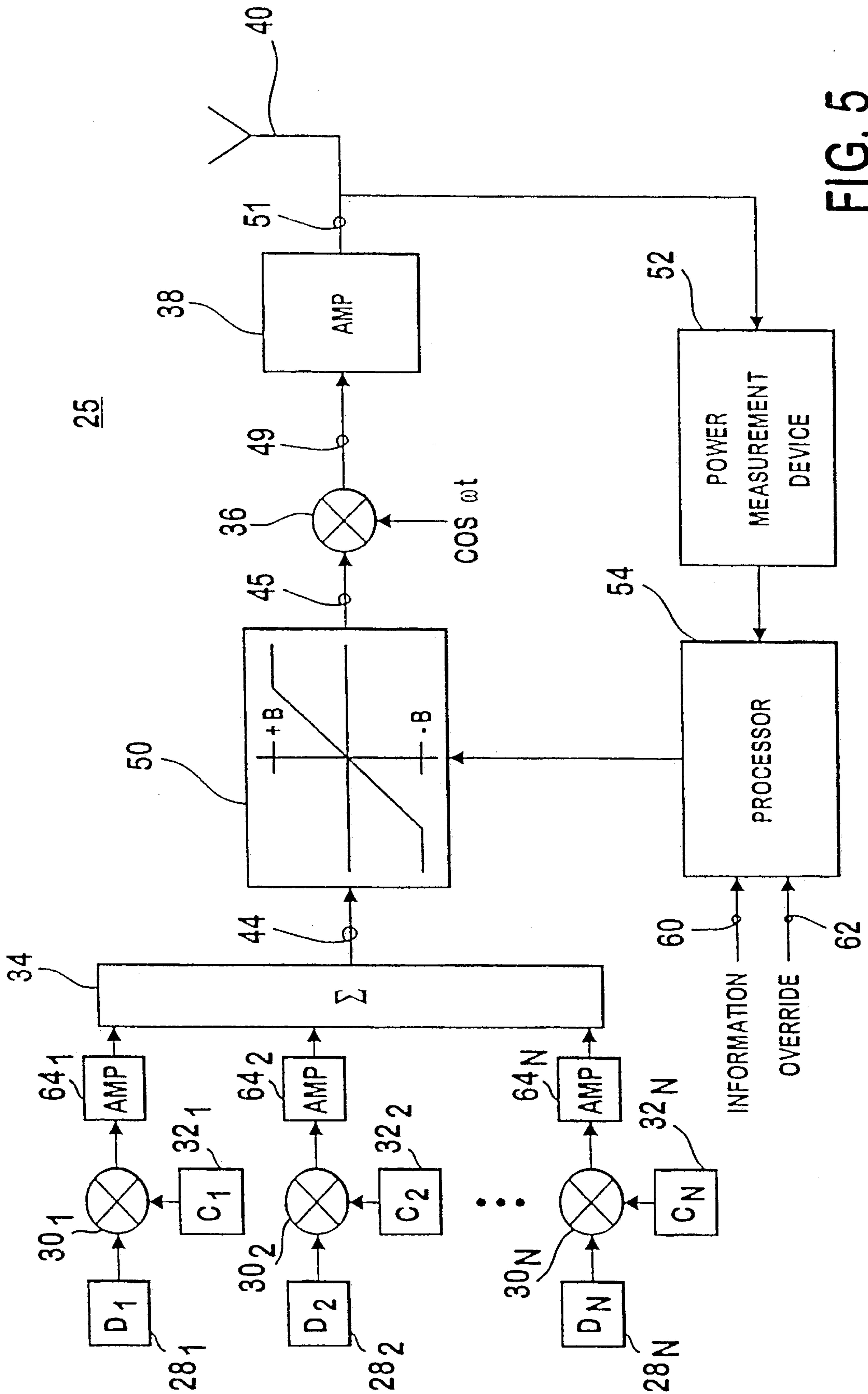

FIG. 5

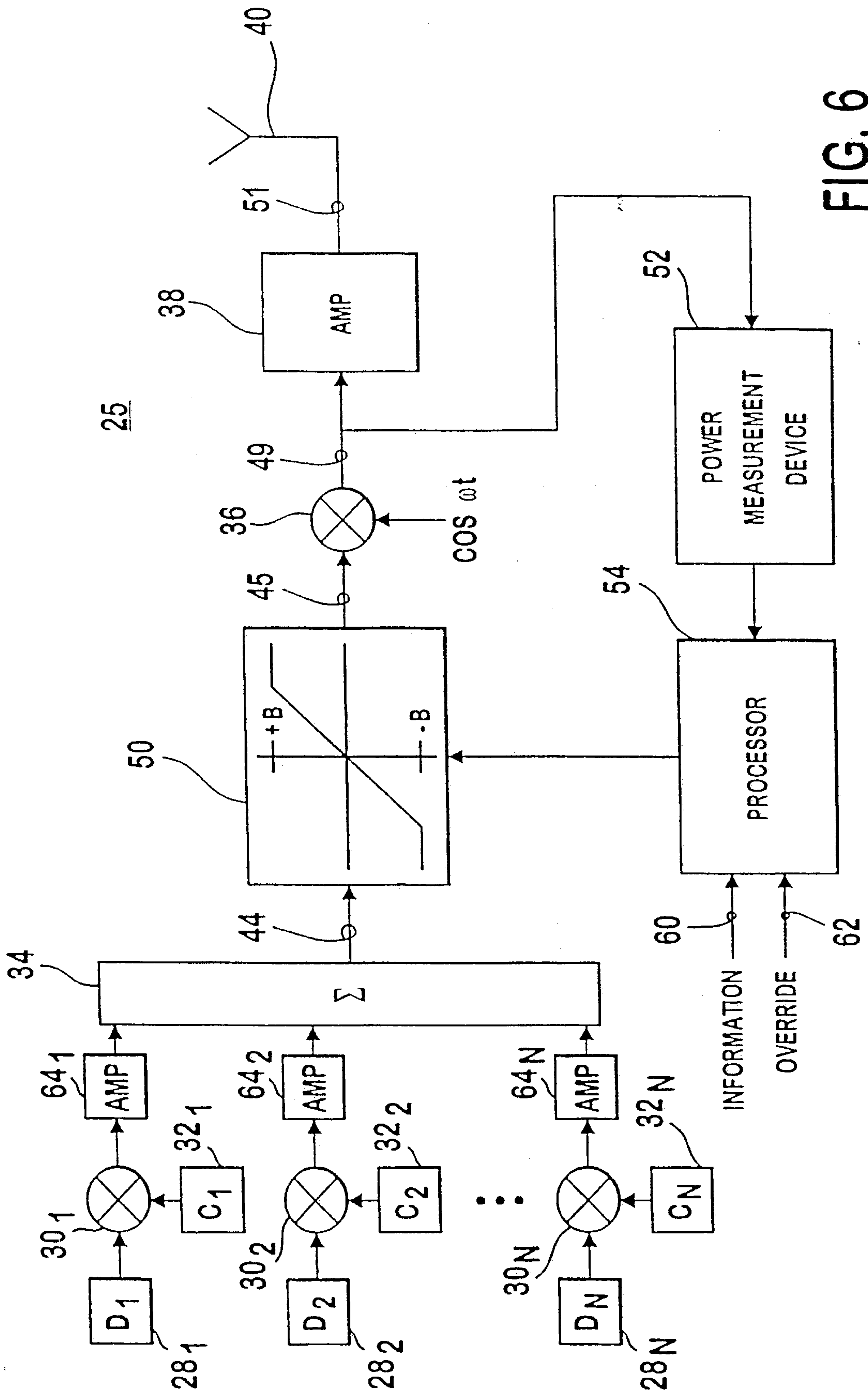

FIG. 6

719

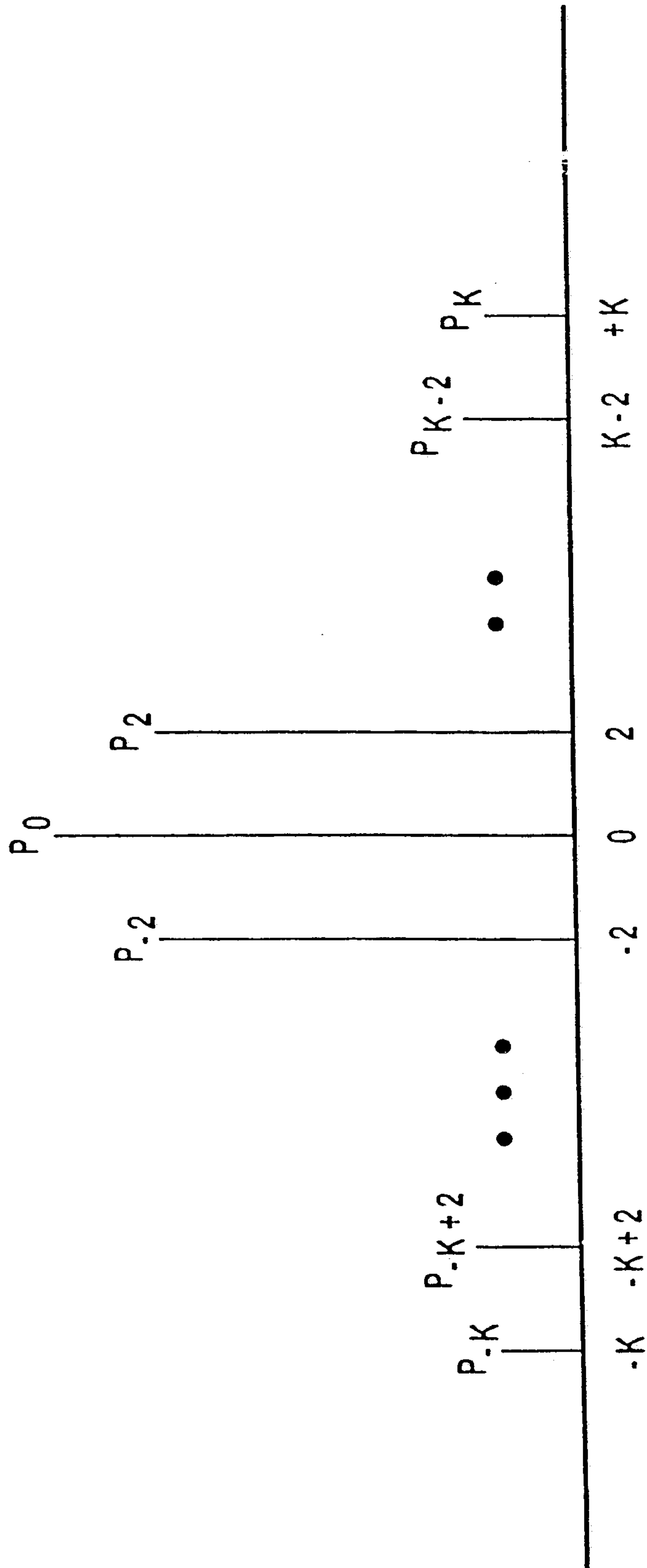

FIG. 7

8/9

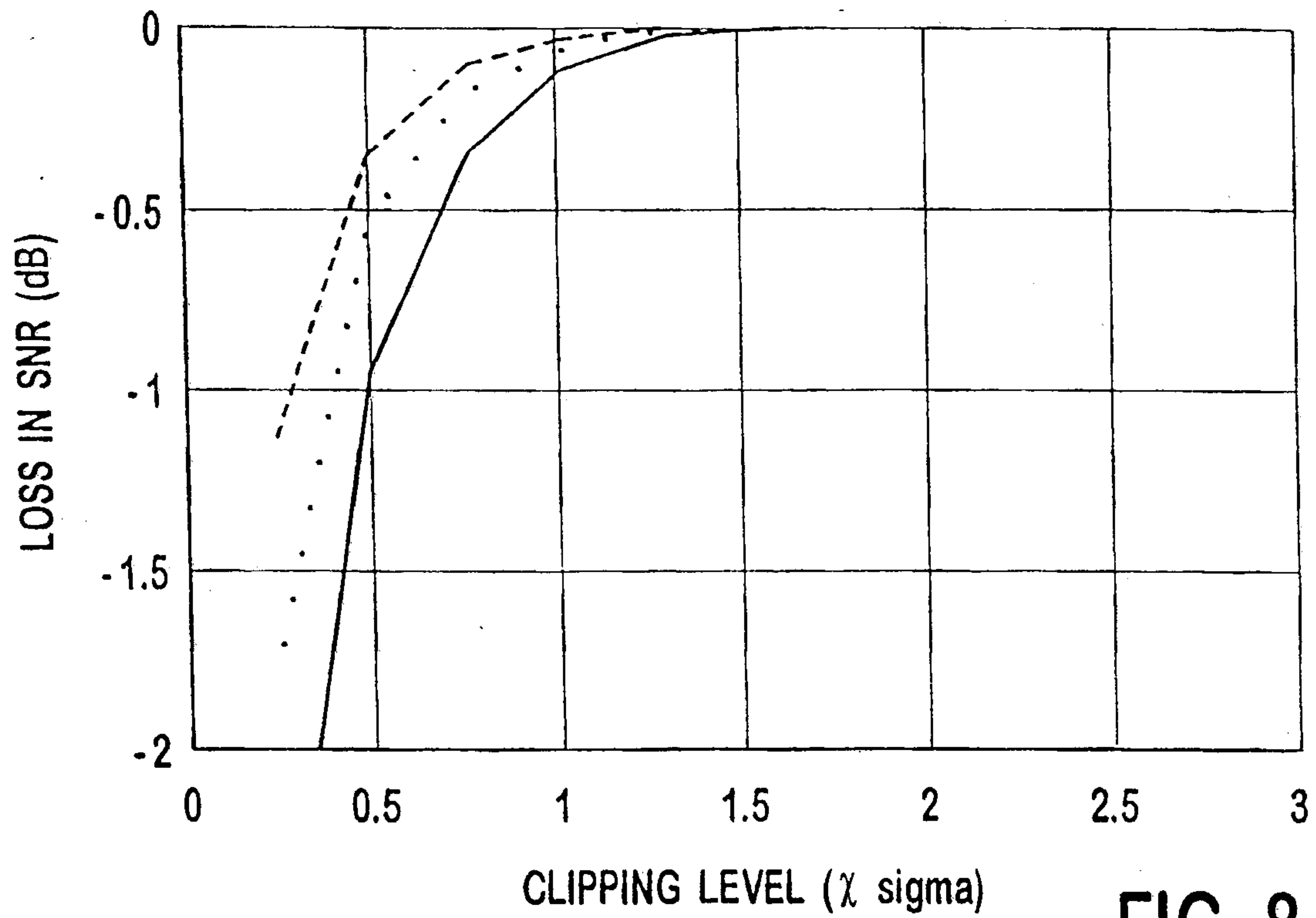

FIG. 8

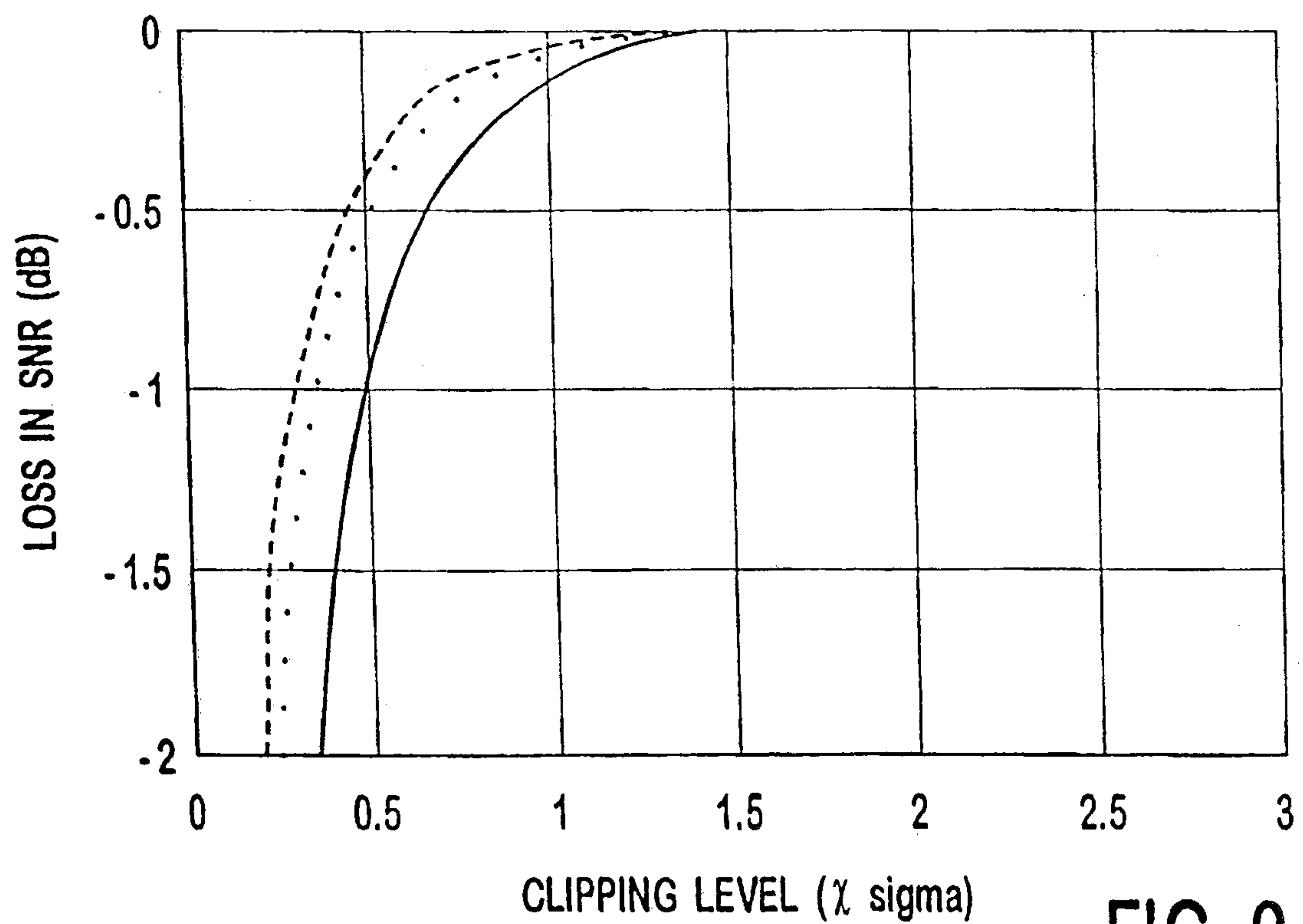

FIG. 9

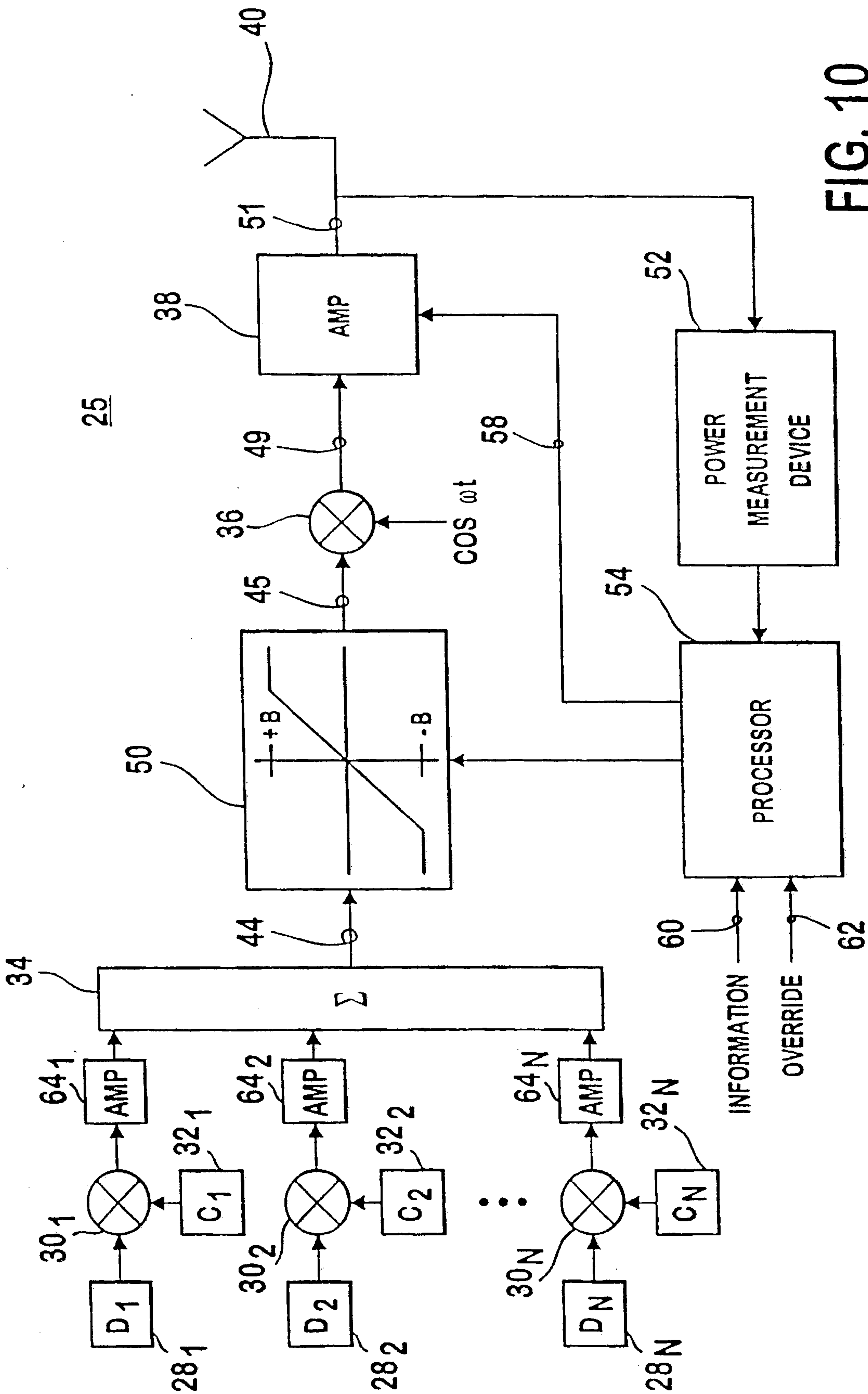

FIG. 10

