

(19) **DANMARK**

(10) **DK/EP 3214923 T3**



Patent- og
Varemærkestyrelsen

(12) **Oversættelse af
europæisk patentskrift**

-
- (51) Int.Cl.: **A 01 J 5/00 (2006.01)** **A 01 K 1/00 (2006.01)** **A 01 K 1/12 (2006.01)**
- (45) Oversættelsen bekendtgjort den: **2020-06-15**
- (80) Dato for Den Europæiske Patentmyndigheds bekendtgørelse om meddelelse af patentet: **2020-03-18**
- (86) Europæisk ansøgning nr.: **15791584.4**
- (86) Europæisk indleveringsdag: **2015-11-05**
- (87) Den europæiske ansøgnings publiceringsdag: **2017-09-13**
- (86) International ansøgning nr.: **EP2015075836**
- (87) Internationalt publikationsnr.: **WO2016071459**
- (30) Prioritet: **2014-11-06 EP 14192024**
- (84) Designerede stater: **AL AT BE BG CH CY CZ DE DK EE ES FI FR GB GR HR HU IE IS IT LI LT LU LV MC MK MT NL NO PL PT RO RS SE SI SK SM TR**
- (73) Patenthaver: **Lemmer Fullwood GmbH, Oberste Höhe, 53790 Lohmar, Tyskland**
- (72) Opfinder: **Lemmer, Jan-Eric, c/o Lemmer Fullwood GmbH, Oberste Höhe, 53790 Lohmar, Tyskland**
- (74) Fuldmægtig i Danmark: **Plougmann Vingtoft A/S, Strandvejen 70, 2900 Hellerup, Danmark**
- (54) Benævnelse: **FREMGANGSMÅDE OG INDRETNING TIL TIDSMÆSSIG FORUDBESTEMBAR AUTOMATISK MALKNING AF DYR**
- (56) Fremdragne publikationer:
WO-A1-2005/092085
WO-A1-2008/003341
NZ-A- 240 967

The invention relates to a device and a method for temporally configurable automatic milking ("batch milking") of animals of a herd with the animals providing liquid from udders, according to claims 1 and 4, respectively.

5

Said animals are in particular cows. Examples of other animals for which the device can be used are goats or sheep.

For automatic milking of cows of a herd, milking robots are increasingly used.

10

The idea is that cows autonomously visit a milking robot in the so-called free cow traffic or selective cow traffic. In general, these two concepts have proven to be effective in practice.

Nevertheless, there may be reasons for leading an entire herd of cows or parts

15

of the cow herd to a group of milking robots in a controlled manner in order to milk in this way all cows of the herd or a group of the herd, respectively, consecutively at fixed times of the day, for example. In this way, cows are also milked which would not (yet) visit the milking robot on their own, even though they should be milked. Reasons for this can be, for example, the degree of saturation of a cow which has eaten enough, for example, and therefore cannot be tempted by the milking robot's attractant feed to visit the milking robot. Another reason may be that especially during summer time a cow is reluctant to leave its shady place on the pasture although the cow should actually be milked.

20

25

From WO-A-2008/003341 a device for temporally configurable milking of cows by means of milking robots is known. The herd to be milked is located in a waiting room equipped with a cow guiding unit, which is preceded by a rotary platform. Longitudinally to circumferential partial area of the rotary platform several milking robots are located to which the cows, which get one after the another from the waiting area out onto the rotary platform, are automatically guided. A so-called separation of the cows takes place which are thus individually and successively transported to the milking robots.

30

Another known device for automatically guiding cows to milking robots is known from US-A-2011/0308465. The cows are guided by means of a cow guiding unit from a waiting area via a (separation) lock to the chambers of a rotary platform which rotates past the lock and on which the cows are automatically milked.

5

In WO-A-2005/092085 a round stable is described having a rotating cow guiding unit which guides the cows to a milking robot arrangement. Said known rotary cow guiding unit cannot be applied to the devices according to WO-A-2008/003341 or US-A-2011/0308465 since translationally movable cow guiders are already realized in said known devices. Particularly in the device according to WO-A-2008/003341 a rotary cow guiding unit preceding the milking robots can also not be used since the rotary platform preceding the milking robots in said known device fulfills a cow separation function which cannot be realized by a rotary cow driver. In the device according to US-A-2011/0308465 no stationary milking robots are used but a milking robot carousel such that the additional arrangement of a rotary cow guiding unit would be senseless in this respect.

10
15

In DE-A-10 2004 036 128 and NZ-A-240967 further examples for cow guiding units are described.

20

An object of the invention is to facilitate the temporally configurable and, in this respect, controlled, automatic milking of animals of a herd providing liquid from udders.

25 According to the invention, the object is achieved by a device according to claim 1 and/or a method according to claim 4.

The object is achieved with the invention according to a further variant proposing a device for temporally configurable automatic milking of animals of a herd, in particular cows, providing liquid from udders, wherein the device is provided with

30

- a plurality of milking robots arranged on a ground for automatic milking of animals,

- 3 -

- wherein each milking robot comprises an entry and an exit and milking equipment being automatically attachable to the udder of an animal,
- a closed waiting area for the animals of a herd to be milked which is located before one of the entries of the milking robots,
- 5 - wherein the waiting area comprises an entrance for bringing the animals from a common area, in which animals not to be milked are also located, to the waiting area, and
- an animal guiding unit for automatically guiding animals in the waiting area to the entries of respective milking robots getting available,
- 10 - wherein the milking robots are arranged next to each other along a curved line, in particular an at least partial circle line,
- wherein the entries of the milking robots are directed towards the waiting area which is at least partially surrounded by the milking robots, and
- wherein the animal guiding unit comprises a fixed leading element protruding into the waiting area and particularly protruding from the entrance of
- 15 the waiting area into the waiting area, and a circularly movable guiding element penetrating the leading element.

- According to the invention, the aforementioned object is further achieved according to another variant by a method for temporally configurable milking of
- 20 animals of a herd, in particular cows, providing liquid from udders, in which
- a plurality of milking robots is provided on a ground along at least a partial circle line, each of which comprises an entry, an exit and a milking equipment being automatically attachable to the udder of an animal,
 - 25 - the animals of the herd to be milked are guided to a closed waiting area located before the entries of the milking robots into which the animals get from a common area in which animals not to be milked are also located, and
 - the animals in the waiting area are guided by means of an automatic circularly movable animal guiding unit one after the other to the entries of
 - 30 respective milking robots getting available.

Correspondingly, the simultaneous use of a plurality of milking robots for automatically milking the animals of a herd is proposed with the invention, wherein said animals are guided "manually" or automatically to the milking robots. This can take place twice (e.g. in the morning and in the evening) or three times a day. The milking robots each comprise an entry through which the animal enters the milking stations, teat cups which, when the animal is in/at the milking robots, are automatically attached to the udder of the animal, and an exit through which the milked animal leaves the milking robot or moves away therefrom, respectively. Obviously, the milking robot may comprise further technical facilities, such as a feeding facility and a cleaning facility for the udder, which are not necessarily required within the scope of the invention.

According to the invention, the group of milking robots is preceded by a waiting area which is locally closed and in which the animals of a herd still to be milked are located, while animals are milked in the milking robots. The animals of the herd to be milked are manually or automatically guided into the waiting room, namely for example by one person or several persons. Once the animals are in the closed waiting area, they are guided from the waiting area by an automatic animal guiding unit one after the other to milking robots getting available.

Thus, it is possible with the concept according to the invention to milk cows of a herd fully automatically at configurable times in a comfortable way.

With regard to the size of the waiting area, said size can be determined by the fact that once a cow has been guided to the waiting area, the cow must wait a maximum of a predefined time (e.g. 1 hour) until it is milked. The size of the waiting area depends, inter alia, on the number of applied milking robots and the duration of the milking cycle per milking robot.

In a further expedient embodiment of the invention, as usual for milking robots, their entries and exits are each optionally closable.

There are various constructive implementations for animal guiding units. It is possible, for example, to configure the waiting area in a substantially rectangular shape, wherein the entrance to the waiting area should be positioned on the side of the waiting area opposite the milking robots. The animal guiding unit for such a waiting area comprises a gate or a wall which is movable from the entrance of the waiting area to the milking robots. A certain disadvantage of such constructions is that the gate or the wall, i.e. the guiding element, when it has been moved forward to the entries of the milking robots and all animals have been milked or the last animals are still in the milking robots, must first be moved back to the entrance of the waiting area in order to be ready for automatically guiding the next group of cows to be milked.

A much more elegant way to realize an animal guiding unit is to rotate the guiding element about a vertical rotary axis of a circular surface, namely circumferentially. The waiting area is now on the one hand defined by the circumference of the circle and by a fixed leading/delimitation element radially extending from the entrance of the waiting area to the center point of the circle, wherein the guiding element cogs with the leading/delimitation element. In other words, the leading element is penetrated by the guiding element upon rotational movement of the guiding element. For this purpose, the guiding element and the leading element may each consist of individual vertical bars or posts, wherein the bars or posts of the driving element, respectively, are arranged with gaps to the bars or posts of the leading element, respectively. Such systems are generally known.

Expediently, in an advanced embodiment of the invention, an animal guiding unit having a guiding element is used which is rotatable about the center point of a circle and extends between the center point of the circle on the one hand and the circumference of the circle on the other hand. The cows led through one of the two sides of the leading element into the waiting area are guided in this manner by the guiding element "in a circle" and thus get to the milking robots which are arranged next to each other along the circumference of the circle.

In a further advantageous embodiment of the invention, the device can be stationarily arranged on a displaceable floor in order to be displaceably placed on a pasture or in a stable, for example. Alternatively, it is also possible that the milking robots are stationarily arranged on a stable floor; accordingly the waiting area is also stationarily arranged in the stable.

The invention allows for a fully automatic milking of dairy cattle herds at defined times (in the sense of an automatic milking system) and thus a practical utilization of the milking stations of 100 % to be achieved. Moreover, the facility remains flexibly extendable to a possible enlargement of the herd. The device according to the invention can be arranged in a partial area of a stable which comprises, in addition to the waiting area with a cow guiding unit and the milking robots, a common area in which the cows are located if they are not (should not be) milked.

In the following, the invention is described in detail by means of an exemplary embodiment and with reference to the drawing. The drawing is a plan view of an exemplary arrangement of a group of, in this case, 10 milking robots along a partial section of the circumference of circular waiting area in plan view.

The figure shows a plan view of a device 10 for automatically milking cows at configurable times. The device 10 comprises a waiting area 12 being circular in plan view which is closed by a wall or a gate 14 which extends along the circumferential line. In a section of, in said exemplary embodiment, about 150°, five double milking robot arrangements 16 are positioned outside and adjacent to waiting area 12. Each milking robot 18 comprises an optionally closable entry 20 and an optionally closable exit 22. Moreover, 24 shows per milking robot 18 a milking equipment being automatically attachable to the udder of the cow to be milked.

The entries 20 of all milking robots 18 are directed towards the waiting area 12, wherein the waiting area 12 is delimited between the entries of neighboring double milking robot arrangements 16 by gate sections 26.

Via an entrance 28, cows 30 to be milked get from a pasture 32 to the waiting area 12, for example.

5 As can be recognized in the drawing, a stationary leading/delimitation element 36 extends from the one side 33 of the entrance 28 into the waiting area 12 up to the center 34 of the waiting area 12, wherein the leading/delimitation element 36 prevents that the cows 30 getting into the waiting area 12 via the entrance 28 immediately get to the nearest milking robots 18 which are arranged to said side 33 of the entrance 28. Thus, the herd is forced to reach the milking robots 18 arranged on the side 33 of the entrance 28 only after passing through the waiting area 12.

To ensure that the cows 30 in the waiting area 12 now successively visit the milking robots 18 getting available, an animal guiding unit 38 is used, which is configured in the form of a rake-like guiding element 40 rotatable about the center 34. In this exemplary embodiment, said guiding element 40 rotates in clockwise direction 41, i.e. it must be able upon its rotational movement to "penetrate" the stationary leading element 36. For this purpose, the leading element 36 is configured in the form of an individual posts 42 protruding from the floor of the waiting area 12, wherein said posts 42 are arranged in radial extension next to each other and are spaced apart from each other such that a cow 30 cannot pass through the area between two neighboring posts 42. The guiding element 40 comprises an overhead bar 46, for example, which is rotatably or movably guided in the center 34 of the waiting area 12 and at its circumferential area, and from which bar 46 posts 48 also extend to the floor of the waiting area. The posts 48 are also spaced apart from each other and are arranged with gaps to the posts 42 of the leading element 36.

30 Other constructions of leading elements and guiding elements are also possible.

The device 10 functions as follows.

The cows of a herd to be milked are led or guided from the pasture via the entrance 28 into the waiting area 12, for example. The cows 30 in the front area get to the milking robots 18 first, while the other cows first have to wait in the waiting area 12. After all cows to be milked are in the waiting area 12, they are
5 guided by advancing the guiding element 40 one after the other to milking robots 18 getting available. Milked cows 30 leave the milking robots 18 via their exits 22 which are directed radially outwards with regard to the circular waiting area 12, where the milked cows 30 get into an aisle 50 and via said aisle 50 back to the pastures 32. At the beginning of said process, the guiding element
10 40 is in the first quadrant I with regard to the plan view of the drawing. The guiding element 40 terminates its advancing movement at the moment when it contacts the last of the waiting cows still to be milked of the waiting area 12. This can be realized by means of an appropriate sensor system or mechanically by pivoting the guiding element 40 in abutment with the cows so that a drive
15 roller disengages from a running track on which it normally rolls.

List of Reference Numerals

	10	device
	12	waiting area
5	14	gate
	16	double milking robot assembly
	18	milking robot
	20	entry of a milking robot
	22	exit of a milking robot
10	24	milking equipment of a milking robot
	26	gate sections between milking robots
	28	entrance to waiting area
	30	cows
	32	pasture
15	33	one side of entrance
	34	center of waiting area
	36	leading/delimitation element
	38	animal guiding unit
	40	pivotable guiding element of guiding unit
20	41	clockwise direction
	42	protruding post of leading/delimitation element
	46	bar of guiding element
	48	post of guiding element
	50	aisle

Patentkrav

1. Indretning til tidsmæssig forudbestembar automatisk malkning af en gruppe af dyr, som giver væske fra yvere, især køer, af en flok omfattende flere grupper af sådanne dyr, med

- 5 - en flerhed af malkerobotter (18) anbragt på et underlag til automatisk malkning af dyr,
 - idet hver malkerobot (18) omfatter en indgang (20) og en udgang (22) og malkeudstyr (24), som automatisk kan fastgøres på yveret på et dyr,
 - en lukket venteområde (12) til dyrene i en flok, som skal malkes, placeret
10 før en af indgangene til malkerobotterne (18),
 - idet venteområdet (12) omfatter en adgang (28) til at føre en gruppe af dyr, som skal malkes, fra et opholdsområde til venteområdet (12), og
 - en dyreførerenhed (38) til automatisk at føre dyrene i venteområdet (12) til indgangene af de respektive malkerobotter (18), som bliver ledige,
15 - idet malkerobotterne (18) er indrettet ved siden af hinanden langs en buet linje, især en i det mindste delvis cirkellinje,
 - idet indgangene til malkerobotterne (18) peger mod venteområdet (12) omgivet i det mindste delvist af malkerobotterne (18), og
 - idet dyreførerenheden (38) omfatter et i venteområdet (12) udragende
20 og især fra adgangen (28) af venteområdet (12) ind i dette udragende, ubevægeligt føringselement (36) og et i dette gennemtrængende, cirkulært bevægeligt førerelement (40).

2. Indretning ifølge krav 1, **kendetegnet ved, at** indgangen (20) og/eller
25 udgangen (22) af hver malkerobot (18) eventuelt kan lukkes.

3. Indretning ifølge krav 1 eller 2, **kendetegnet ved, at** underlaget er græs, et staldgulv eller et transportabelt gulv, på hvilket malkerobotterne (18) er anbragt, især fastgjort.

30 **4.** Fremgangsmåde til tidsmæssig forudbestembar malkning af en gruppe af dyr, som giver væske fra yvere, især køer, af en flok omfattende flere grupper af sådanne dyr ved hjælp af en indretning ifølge et af kravene 1 til 3, hvor i denne fremgangsmåde

- en flerhed af malkerobotter (18) som tilvejebringes på et underlag langs en i det mindste delvis cirkellinje, og som hver omfatter en indgang (20), en udgang (22) og malkeudstyr (24) som automatisk kan fastgøres på yveret på et dyr,
- 5
- en gruppe af dyr fra flokken, som skal malkes, føres til et lukket venteområde (12) placeret før indgangene til malkerobotterne (18), hvor dyrene kommer fra et opholdsområde, og
 - dyrene i venteområdet (12) føres ved hjælp af en automatisk cirkulært bevægelig dyreførerenhed (38) et efter et til indgangene af de respektive
- 10
- malkerobotter (18), som bliver ledige.

-1/1-

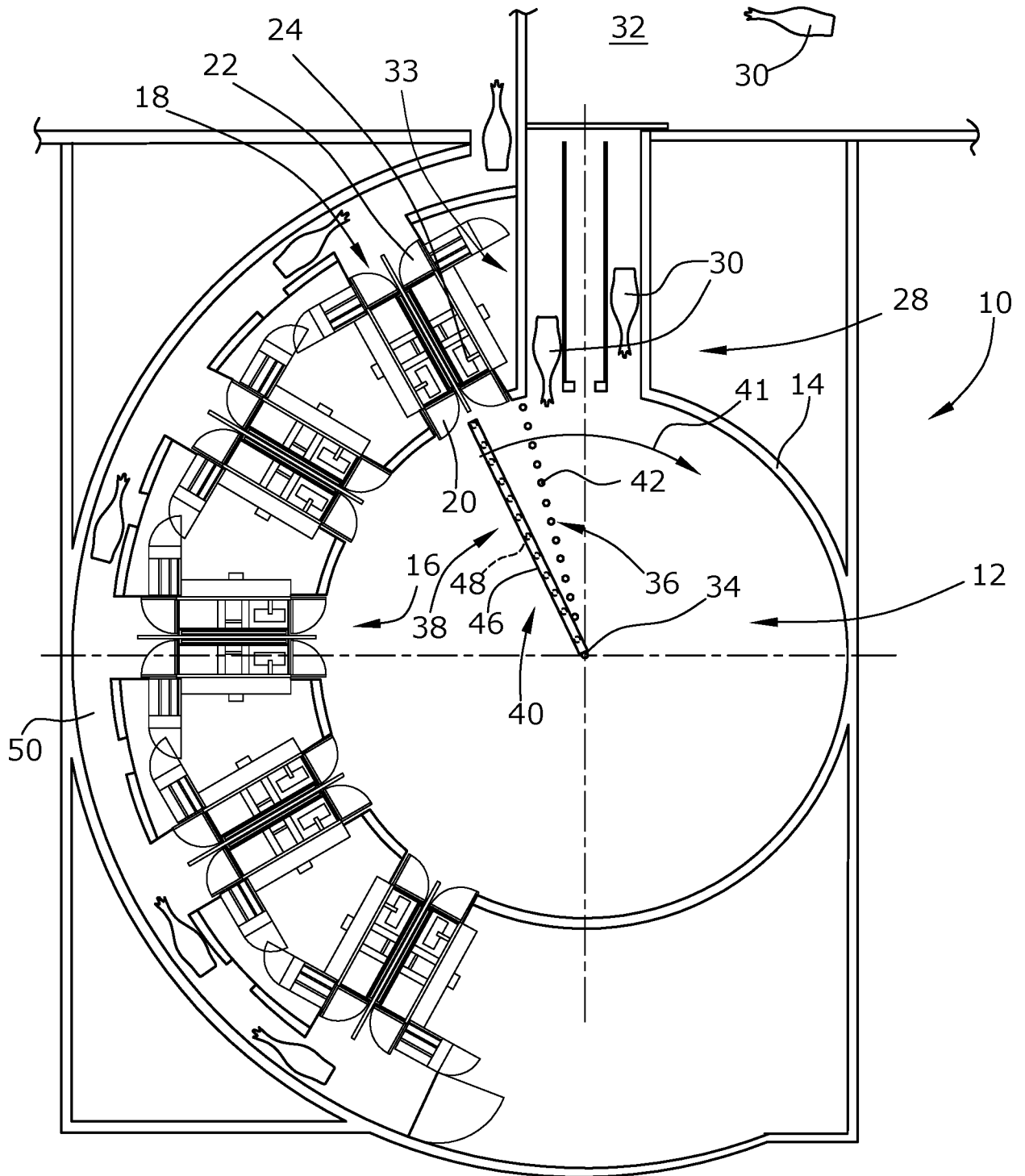

Figure 1