

Nov. 11, 1958

J. C. GALLOP, JR

2,859,627

MULTIPLE PURPOSE POWER TOOL

Filed Feb. 16, 1954

2 Sheets-Sheet 1

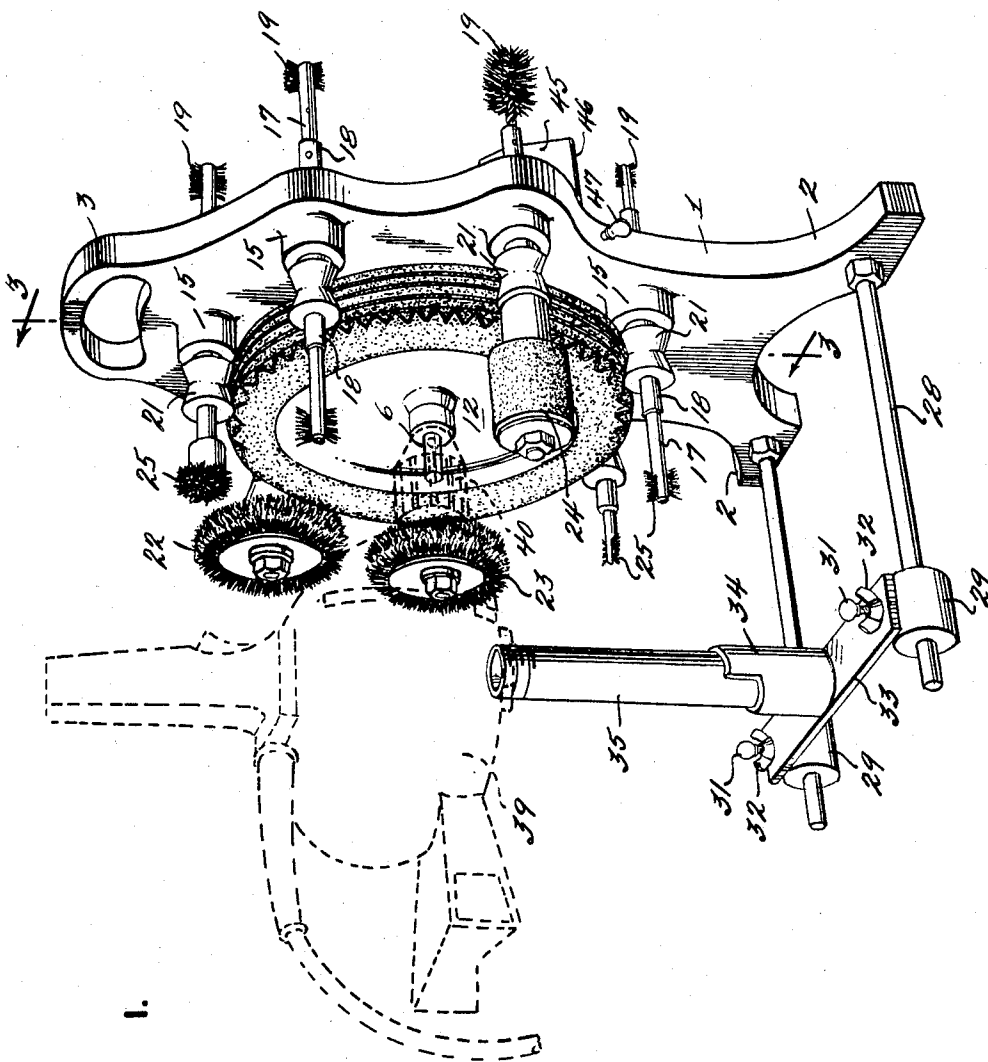

FIG. 1.

INVENTOR
JOHN CALVIN GALLOP, JR.

By
Hemmes + Hemmes
ATTORNEYS

Nov. 11, 1958

J. C. GALLOP, JR

2,859,627

MULTIPLE PURPOSE POWER TOOL

Filed Feb. 16, 1954

2 Sheets-Sheet 2

FIG. 3.

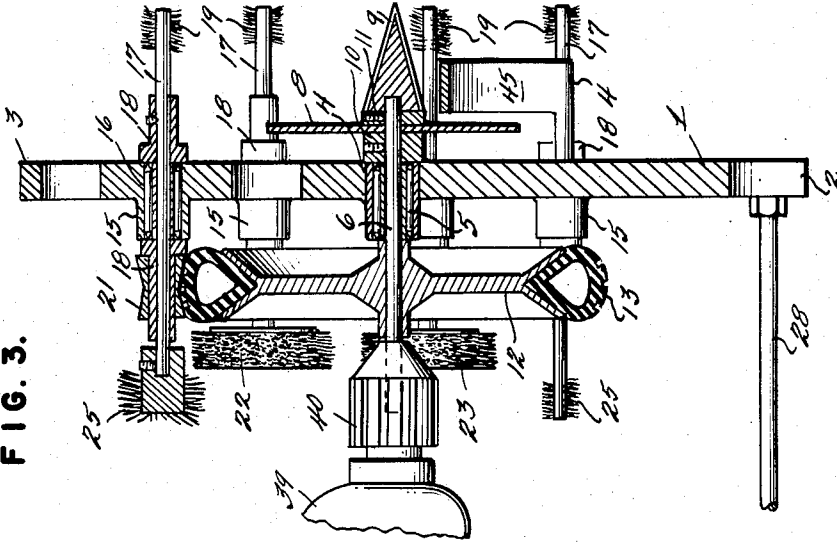
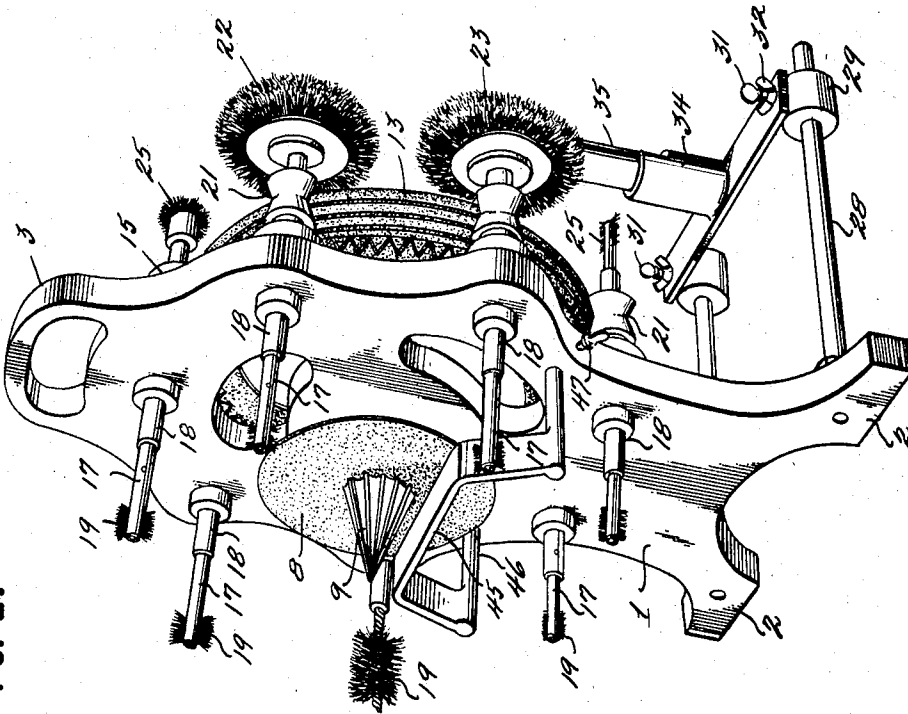

FIG. 2.



INVENTOR
JOHN CALVIN GALLOP, JR.

By

Semmes & Semmes
ATTORNEYS

1

2,859,627

MULTIPLE PURPOSE POWER TOOL

John Calvin Gallop, Jr., Norfolk, Va.

Application February 16, 1954, Serial No. 410,531

8 Claims. (Cl. 74-16)

The present invention relates to power tools and more particularly to an auxiliary portable attachment for a conventional electric drill.

Building and maintenance men are presently confronted with an increasing trend toward the use of copper tubing and piping in fluid conduits. Refrigeration service, new air-conditioning installations and the like involve considerable processing of tubing of different sizes and weights. Hand-fabrication is tedious and in many instances unsatisfactory. Power driven units can accomplish superior work but constant changing of the tools, brushes and similar attachments of the base power unit is unnecessarily time consuming. In addition, the work piece being handled must be laid aside during the tool changes and accordingly is susceptible of damage during these intervals.

One of the objects of my invention is to provide in a unitary upright bearing block or mounting a plurality of work units so combined and associated that a single driving element may be employed for operating said units simultaneously.

Another object of my invention is to provide in a unitary portable mounting a plurality of work units each of which is instantly available for service.

A further object of my invention is the provision of an improved auxiliary attachment for an electric drill wherein driving power derived from said drill is simultaneously and evenly transmitted to a plurality of work units suitably arranged in a compact grouping through a friction drive.

Further objects and advantages of the present invention will be apparent from the following description, reference being had to the accompanying drawings, wherein a preferred embodiment of the invention is illustrated and in which like reference numerals are used to indicate like parts in the several views.

In the drawings,

Figure 1 is perspective view of a multiple purpose power tool embodying the features of my invention;

Figure 2 is a perspective view of the reverse side of the power tool, and;

Figure 3 is a vertical section taken substantially along the line 3-3 in Figure 1.

In accordance with my invention, there is provided in a unitary mounting a plurality of work units annularly arranged about a central axis and motivated by a common friction drive. A conventional electric drill suitably positioned adjacent said mounting upon an adjustable support forming a part thereof and in spaced relation thereto serves as a supply of motive force for the friction drive.

Referring to the drawings, a light weight upright bearing block 1 of cast metal, such as aluminum, formed to any desired configuration is provided with base members 2 and an opposed handle 3. Centrally of the bearing block 1 is positioned a bearing carrier 4 in which is journaled in a suitable sleeve bearing 5 an axle 6 projecting to each side of the housing.

2

An emery cutting wheel 8 and a reamer cone 9 are secured to the axle at the leading end thereof by a suitable locking device as for example, collars 10 and 11 adapted to the particular attachments. A wheel 12 bearing a pneumatic tire 13 is secured to the axle extending from the opposing side of the bearing block 1, through the medium of a key-way, or comparable device.

A plurality of raised bearing carriers 15 are annularly arranged in regular spaced relation about the central carrier 4 in the bearing block 1 and provide mountings in needle bearings 16 for spindles 17 which project to each side of the bearing block. Detent collars 18 secured to the spindles prevent outward displacement thereof. Various cleaning brushes 19 of differing diameters and types are secured to the outer ends of the spindles 17 by suitable locking devices. Drive rollers 21, with concave surfaces, are splined or otherwise secured to the inwardly extending portions of the spindles 17 in alignment with the tire 13 of the friction drive wheel 12. Thus, as illustrated the power transmission through the tire surface takes place close to the bearing surfaces for the various spindles, reducing the thrust wear and, thus, making it possible to increase friction necessary for an especial use of one spindle by additionally inflating the tire, without causing undue thrust wear on the other spindles. Additional work units, such as a rotary wire brush 22, a buffing brush 23, an emery cloth dressing wheel 24 and other abrading elements 25 are secured to the inner ends of the spindles 17 by suitable locking devices.

In order that the combined work units will be maintained in operable position, horizontal members 28 are removably secured to the base members 2 and extend inwardly therefrom in spaced relation. Collars 29 are mounted upon the members 28 and are movable therealong, set screws 31 and locking wing nuts 32 being provided to lock them in any desired location. Extending between the collars 29 and secured thereto is a strip 33 of metal carrying centrally thereof a socket 34 in which is seated a standard 35. The standard 35 provides an adjustable support for a conventional electric drill 39 capable of handling 1/2" or larger drills. The electric drill 39 is centered with respect to the axle 5 and connected to the inner end thereof through the key chuck 40 thus serving to power the several work units simultaneously.

To facilitate certain of the operations, particularly involving the cutting wheel 8 and the reamer 9 a work rest 45 supported upon spaced arms 46 is adjustably secured to the bearing block 1 by means of set screws 47 in close proximity to said cutting wheel and reamer.

The operation of my device is immediately apparent. The electric drill 39 rotates the wheel 12 which in turn drives the rollers 21 and rotates all of the tool supporting spindles 17 simultaneously. With the particular arrangement illustrated, the tool-supporting spindles will all be driven in the same direction and at the same speed. The cutting wheel 8 and reamer 9, however, being mounted on the central axle 6 are driven directly for increased power. The speed ratio of the tool supporting spindles may be varied by changing the diameters of the drive wheel 12 and the rollers 21. A 4.5 to 1 ratio has been determined to achieve satisfactory performance in the grinding brushes and abrading wheels.

The friction drive provided in my device insures positive and uniform motive power for rotation of the various tools and implements incorporated therein. Variations in spindle alignment and/or wear of the driving elements may be compensated for altering the degree of inflation in the tire 13. Greater inflation of said tire will also provide an increase in friction and a corresponding greater traction for the spindles when such is desired. The friction drive embodies a safety provision

3

in that an excessive load applied to any one element will stop the single spindle involved without affecting the remainder of the device. In addition, the friction drive enables the device to remain in operation even when one or more spindles are removed therefrom.

Although one specific embodiment of the invention has been shown and described, it will be understood that the proposed device is capable of modification and that changes in the construction and in the arrangement of the various component elements may be made without departing from the spirit and scope of the invention as set forth in the following claims.

What I claim is:

1. A multiple purpose portable power tool comprising in combination an upright rigid bearing block, a work rest adjustably secured thereto, pneumatic driving means journaled centrally of said block, at least three spindles centrally bearing in the block, said spindles being disposed radially adjacent the circumferential extremity of the driving means, rotary tools carried by said spindles and a source of rotary power for the driving means.

2. The device claimed in claim 1 in which the spindles project from either side of the block in substantially horizontal planes to bear rotary tools on each end thereof.

3. The device claimed in claim 2 wherein transmission of power from said driving means onto said spindles occurs substantially adjacent the bearing portions of said spindles in said bearing block.

4. A device as claimed in claim 1, said source of rotary power for the driving means being removably supported in adjustable relation to said bearing block.

5. A multiple purpose power tool comprising an upright rigid bearing block, a plurality of spindles centrally journaled in and projecting in substantially horizontal planes from each side of said bearing block in annularly spaced relation, working implements attached to the opposed ends of said spindles, a driving wheel journaled in said bearing block centrally of said spindles and rollers secured to the control portion of each of said spindles frictionally engaging said driving wheel for simultaneous rotation of said spindles.

6. A power tool as defined in claim 5 wherein the central driving wheel is provided with a pneumatic tire.

4

7. A multiple purpose power tool comprising an upright rigid bearing block, a plurality of spindles centrally mounted in needle bearings in annularly spaced relation in said bearing block, said spindles projecting in substantially horizontal planes from each side of said bearing block and having secured to the opposed ends thereof abrading implements, a main axle suitably journaled in said bearing block, a driving wheel provided with a pneumatic tire secured to one end of said axle, a working implement secured to the opposed end of said axle and rollers secured to the control portion of each of said spindles frictionally engaging said driving wheel for simultaneous rotation of the spindles.

8. A multiple purpose power tool comprising an upright rigid bearing block, a plurality of spindles centrally mounted in needle bearings in annularly spaced relation in said bearing block, said spindles projecting in substantially horizontal planes from each side of the carrier housing and having secured to the opposed ends thereof abrading implements, a main axle suitably journaled in said bearing block centrally thereof and of said spindles and projecting from each side of the bearing block, a driving wheel provided with a pneumatic tire secured to one end of said axle on one side of said bearing block, a working implement secured to the opposed end of said axle on the other side of said bearing block, and rollers substantially of spool-shape secured to the central portion of each of said spindles in frictional engagement with said driving wheel, said rollers enabling simultaneous and uniform rotation of the spindles and the abrading implements carried thereby.

References Cited in the file of this patent

UNITED STATES PATENTS

628,337	Krysgeuski	July 4, 1899
688,505	Deibler	Dec. 10, 1901
985,338	Gams	Feb. 28, 1911
1,171,477	Thormahlem	Feb. 15, 1916
1,431,649	Gillette	Oct. 10, 1932
1,537,009	Hagman	May 5, 1925
2,111,422	Fawick	Mar. 15, 1938
2,674,130	Spychalla	Apr. 6, 1954