



(19) **United States**

(12) **Patent Application Publication**
Matsuoka

(10) **Pub. No.: US 2006/0154016 A1**

(43) **Pub. Date: Jul. 13, 2006**

(54) **ARTIFICIAL LAWN AND METHOD OF MANUFACTURING THE SAME**

(52) **U.S. Cl.** 428/92; 428/95; 156/61; 156/72

(76) Inventor: **Ryoichi Matsuoka**, Hyogo (JP)

(57) **ABSTRACT**

Correspondence Address:
BIRCH STEWART KOLASCH & BIRCH
PO BOX 747
FALLS CHURCH, VA 22040-0747 (US)

Imitation lawns are prevented from coming off a laying board 3 due to influence of temperature on an adhesive, secular deterioration of the adhesive, load of an external force exceeding an adhesive strength, load of a strong lateral slide force, and the like.

(21) Appl. No.: **10/560,000**

In an artificial lawn including imitation lawns 2, and a laying board 3 onto which the imitation lawns are planted, the imitation lawns 2 each include a bunch of foliaceous pieces 4 and a root portion 5 which bundles the bunch of foliaceous pieces, while the laying board 3 includes a plurality of root portion pots 6 into which the root portions 5 of the imitation lawns 2 are forcibly fit, respectively. A bifurcate pin member 7 having two pin tips is driven onto an upper part of the root portion 5 of the imitation lawn 2 forcibly fit in the root portion pot 6 of the laying board 3, such that the pin member traverses a middle part of the root portion, from which the foliaceous pieces 4 are parted, and strides across both sides of an opening of the root portion pot 6, whereby the imitation lawn 2 is fixed to the laying board 3.

(22) PCT Filed: **Jun. 23, 2004**

(86) PCT No.: **PCT/JP04/08798**

(30) **Foreign Application Priority Data**

Jun. 30, 2003 (JP) 2003-188439

Publication Classification

(51) **Int. Cl.**
D03D 27/00 (2006.01)

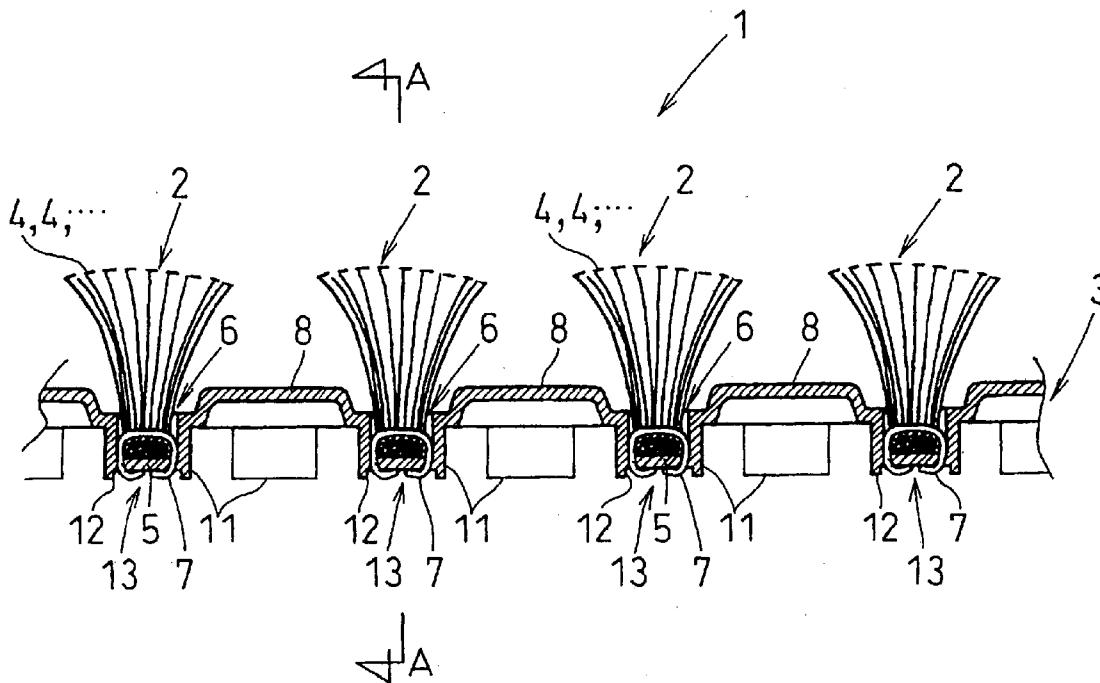

FIG.2

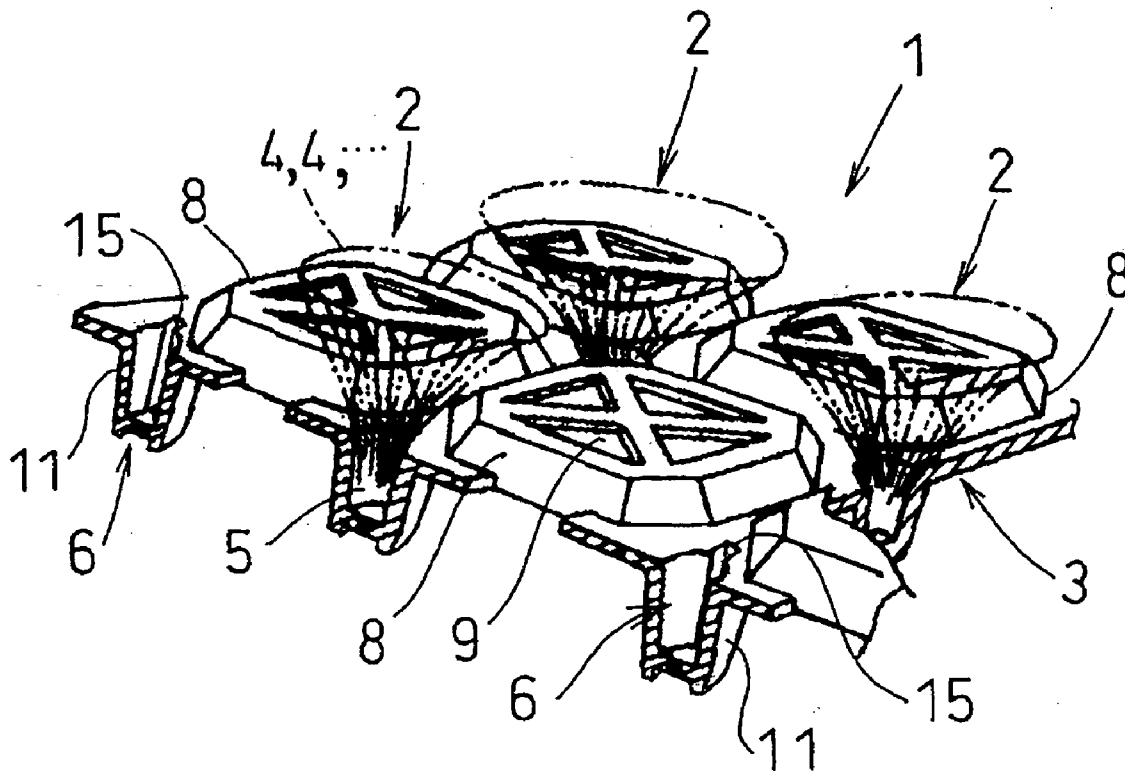

FIG.3

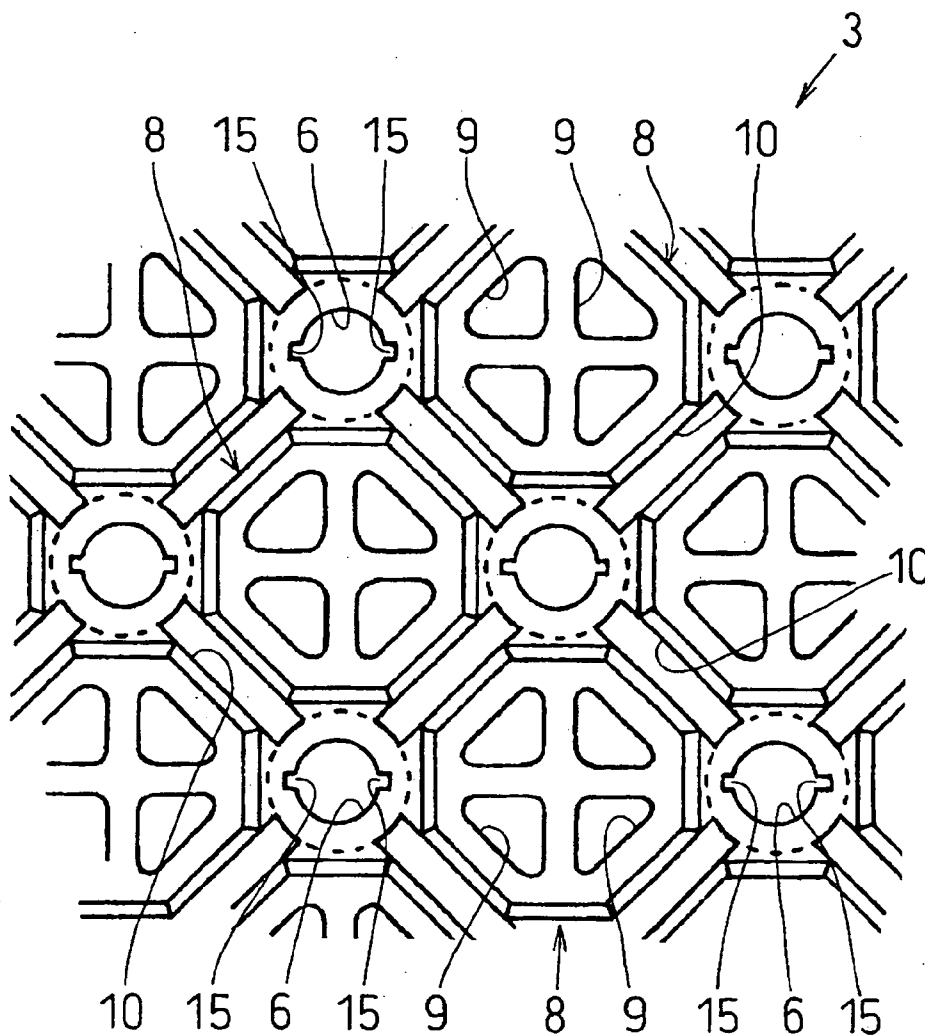

FIG.4

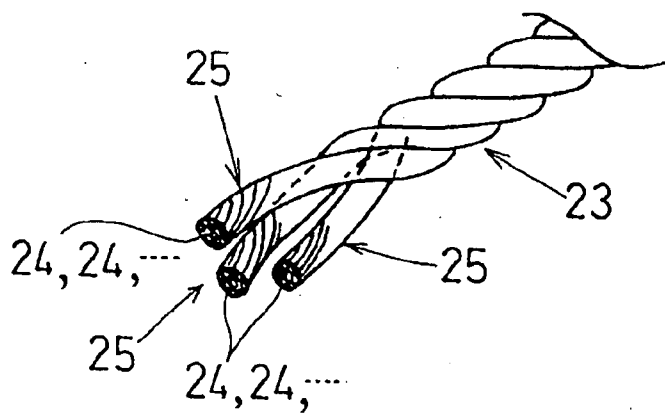

FIG.5

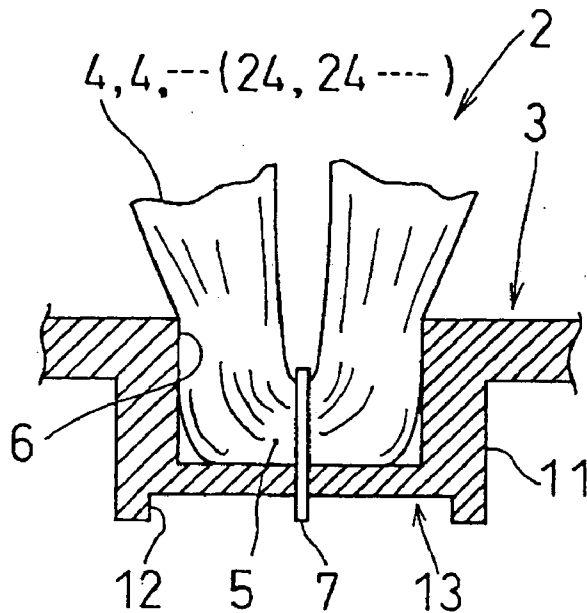

FIG.6

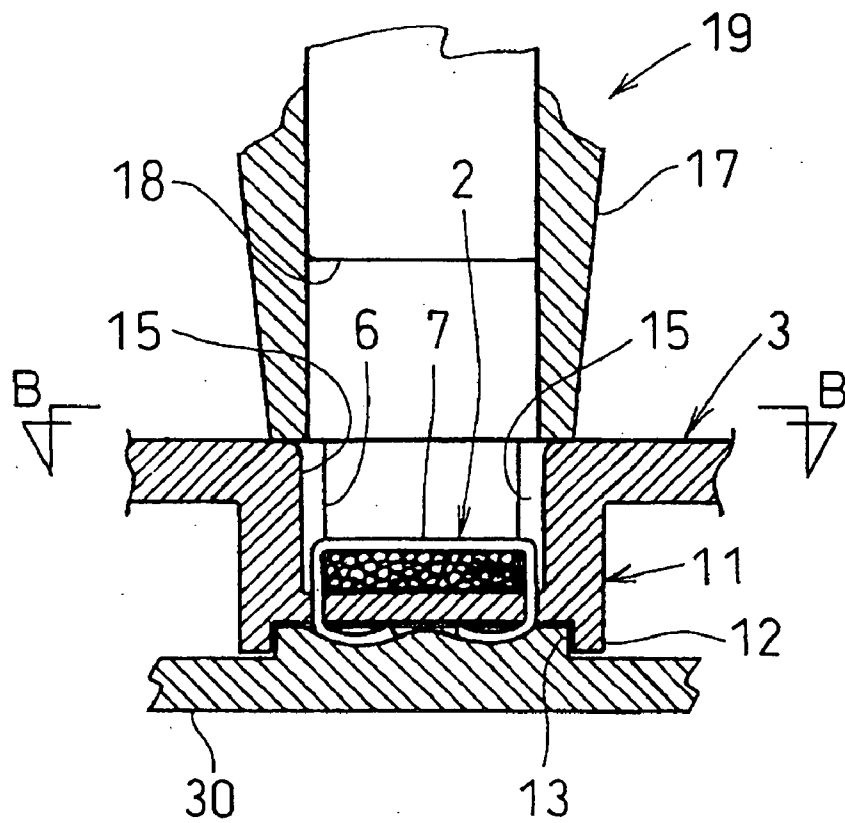

FIG. 7

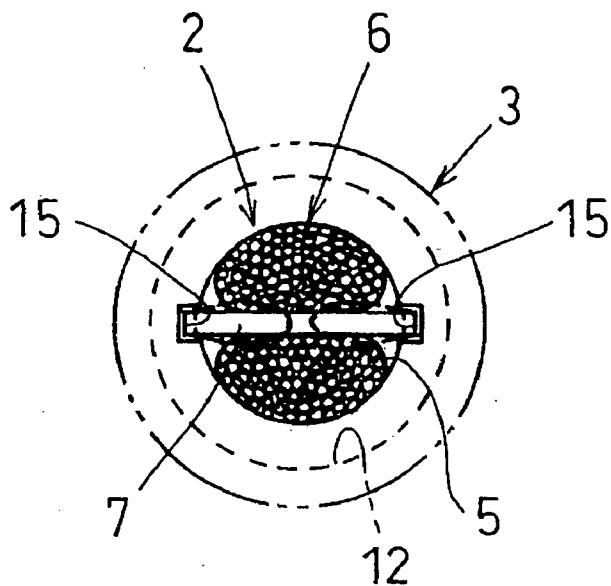

FIG. 8

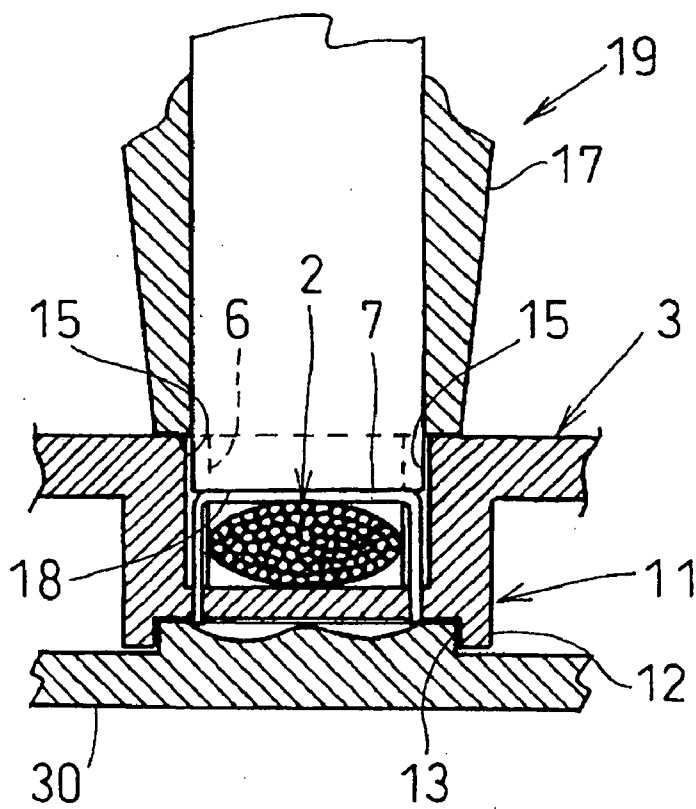

FIG. 9

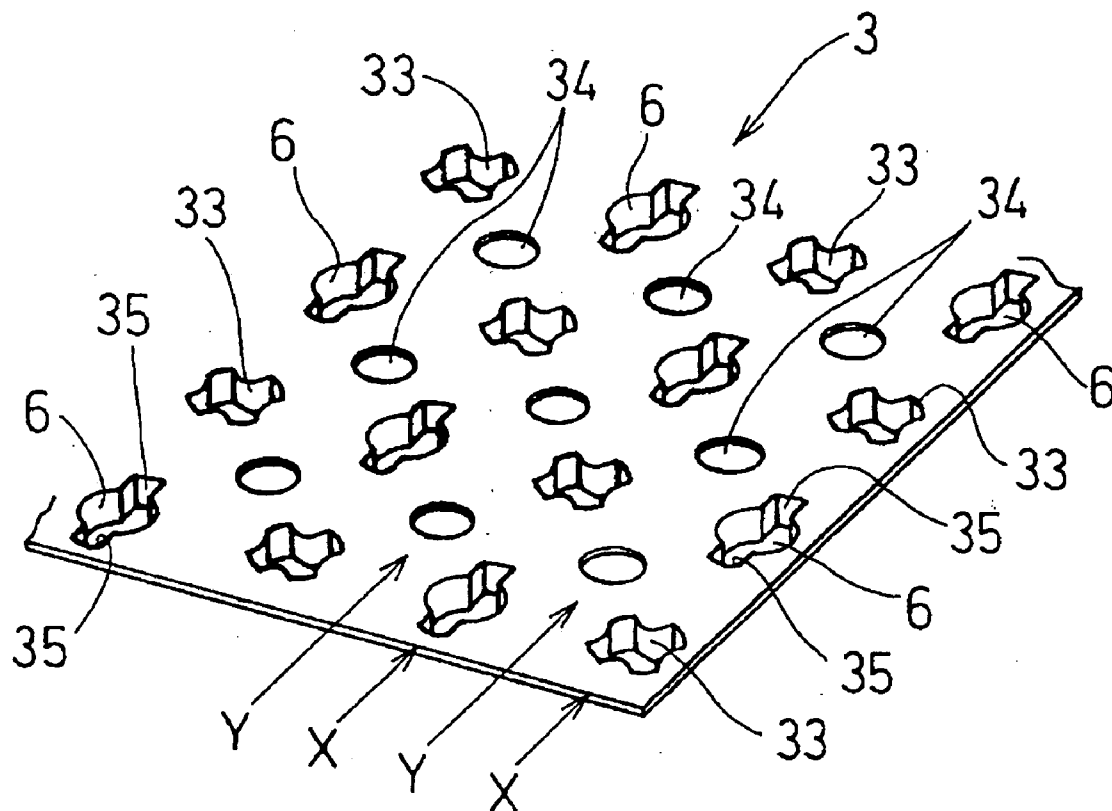

FIG. 10

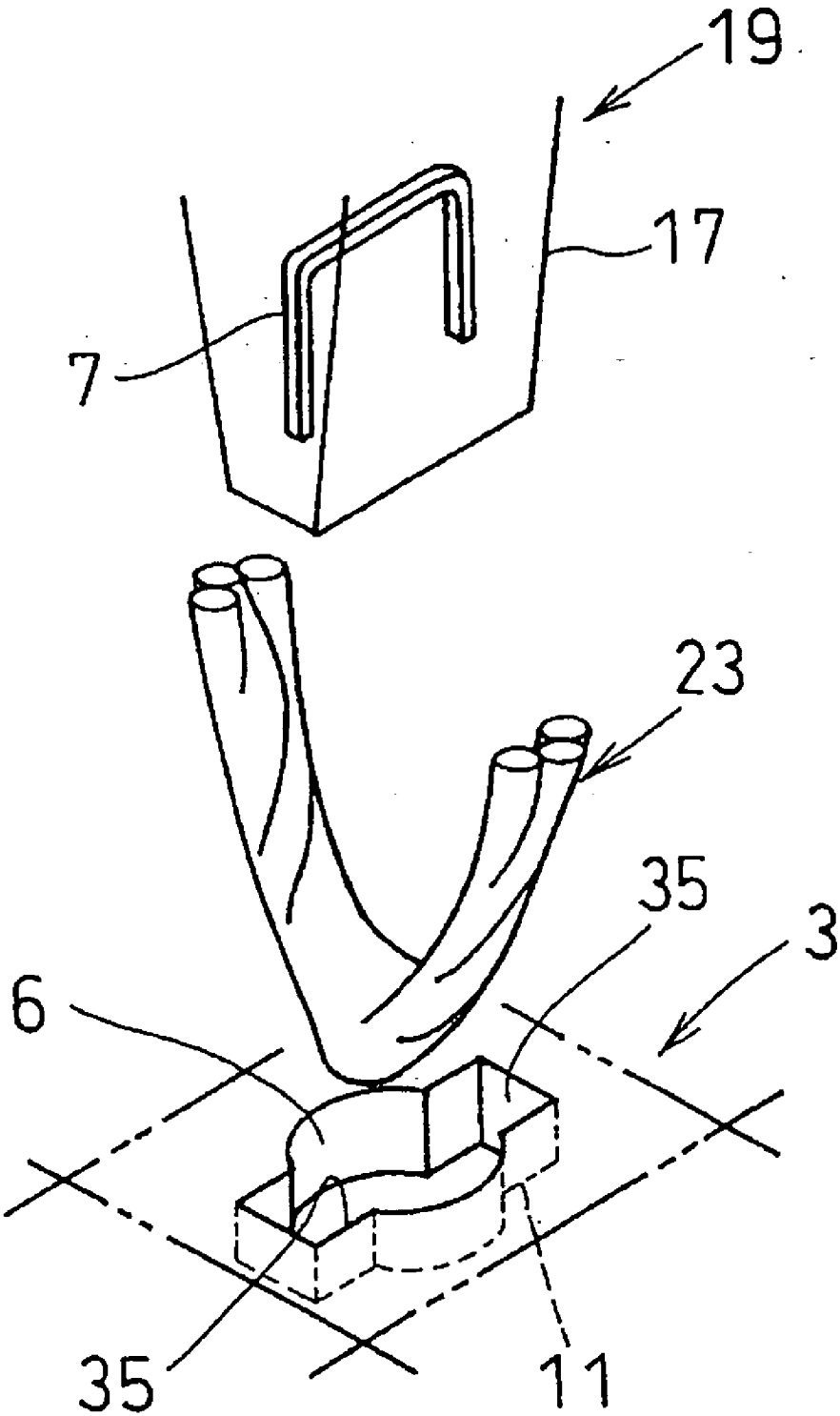

FIG.11

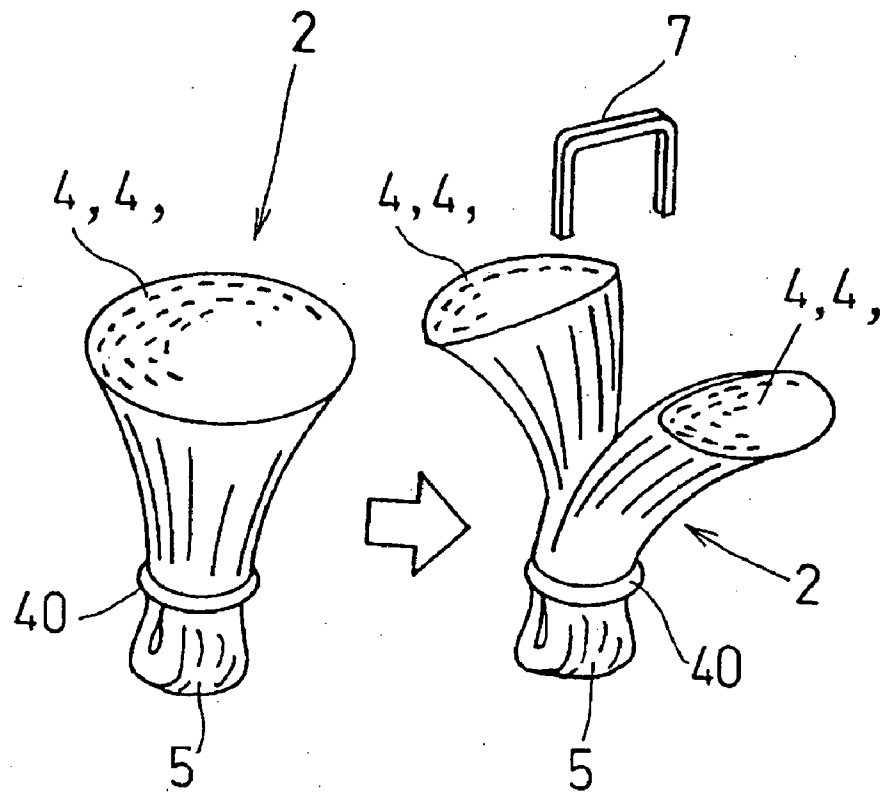

FIG.12

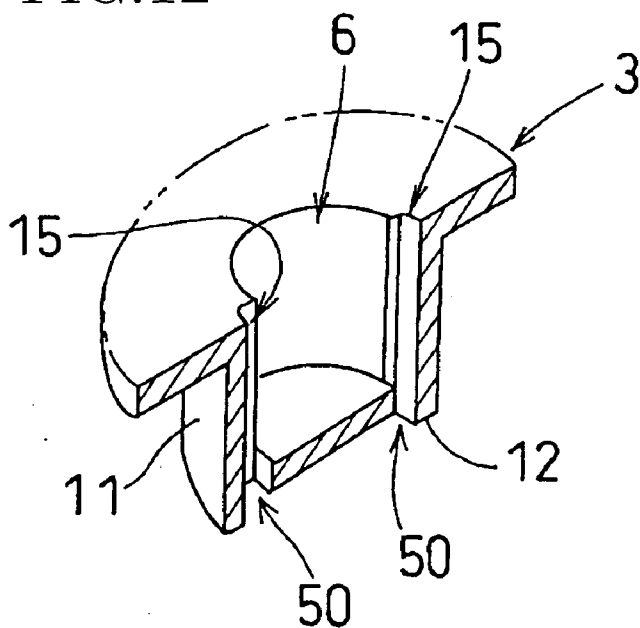

FIG. 13

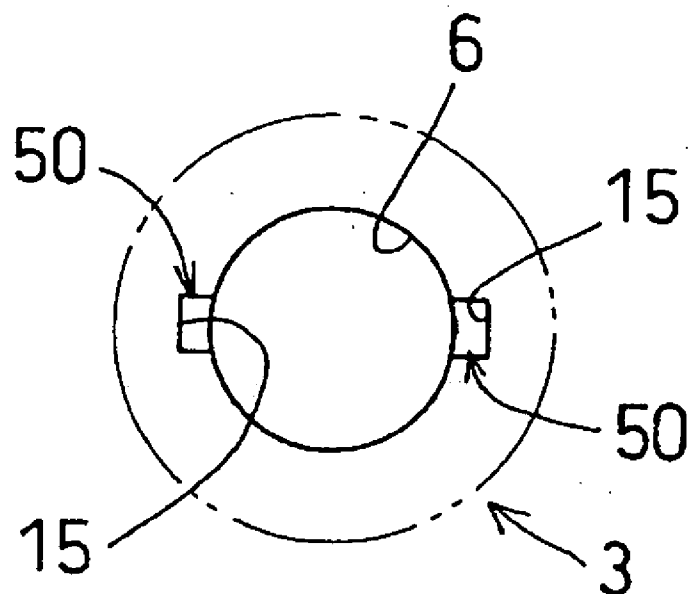

FIG. 14

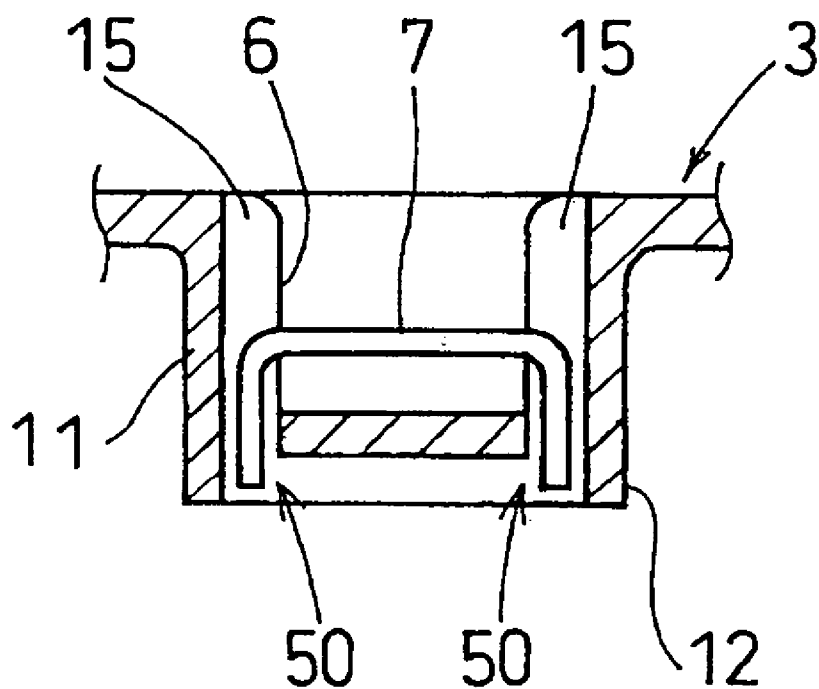

FIG.15

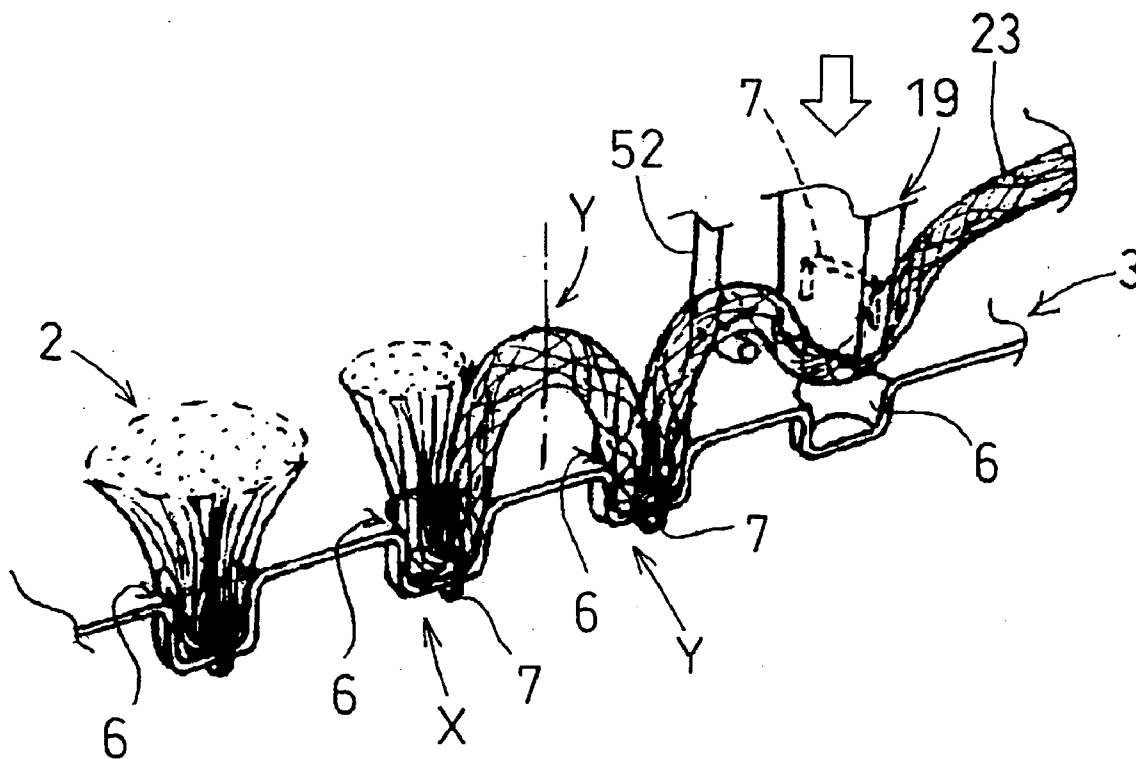

FIG.16

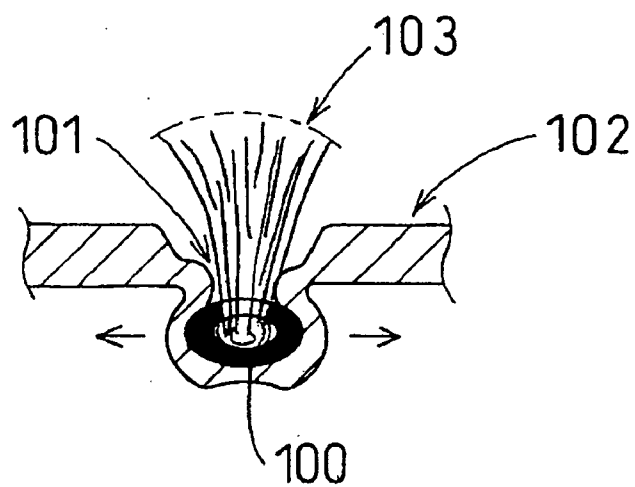
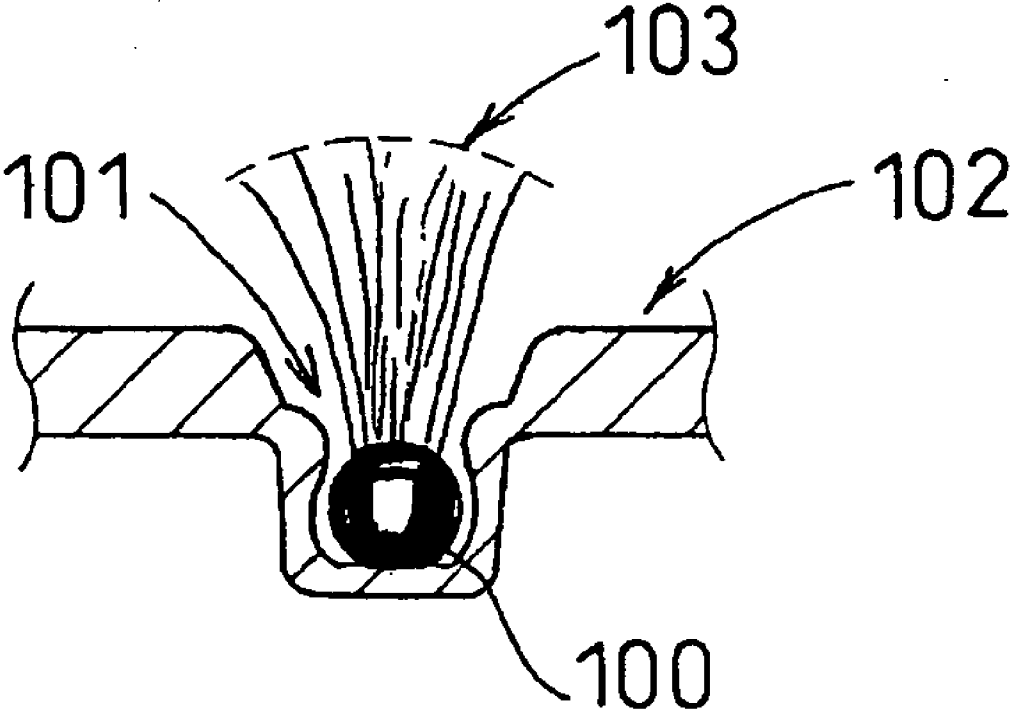

FIG. 17



ARTIFICIAL LAWN AND METHOD OF MANUFACTURING THE SAME

TECHNICAL FIELD

[0001] The present invention relates to an artificial lawn and a method of manufacturing the artificial lawn.

BACKGROUND ART

[0002] There has been a known artificial lawn having imitation lawns, and a laying board for planting the imitation lawns thereonto, wherein the imitation lawns each include a bunch of foliaceous pieces and a root portion which bundles the bunch of foliaceous pieces, and the laying board includes a plurality of root portion pots arranged in an orderly manner into which the root portions of the imitation lawns are forcibly fit, respectively, (refer to, for example, Patent Document 1). The imitation lawns of a large number of roots are planted so that substantially the whole upper surface of the laying board is concealed. Besides, the root portion pots of the laying board serve also as the legs of the laying board (that is, the whole artificial lawn) owing to the external shape of peripheral wall parts forming the root portion pots.

[0003] As a structure for fixing the root portions of the imitation lawns to the root portion pots of the laying board, there have been proposed one wherein metal fittings entwined in the root portion of the imitation lawn are internally fitted so as to be stretched within the root portion pot, one wherein the periphery of the root portion is tied with a wire piece, and the root portion is internally fitted so as to be forcibly fitted into the root portion pot with the wire piece (refer to FIG. 16 or 17), one wherein the root portion is stuck with an adhesive, and so forth (all the techniques are disclosed in Patent Document 1 mentioned above).

[0004] Patent Document 1: JP-A-8-333708

DISCLOSURE OF THE INVENTION

Problems to be Solved by the Invention

[0005] In the case where the adhesive is employed for fixing the root portions of the imitation lawns to the root portion pots of the laying board, there is a problem that the adhesive softens due to temperature, moisture, shocks, exposure to a high temperature environment ascribable to the direct rays of the sun, or the like, causing the imitation lawns to come off the laying board. Needless to say, the imitation lawns have sometimes come off also due to secular deterioration of the adhesive or application of an external force exceeding an adhesive strength. Further, also in a case where the laying board is made of a resin, the softening or deformation of the laying board itself occurs at high temperatures in summer, or the like, causing the imitation lawns to come off the laying board.

[0006] On the other hand, with the fixing structure other than the adhesive (in the case of employing the stretching metal fittings, the forcible fitting wire pieces, or the like), there is a problem that the imitation lawns come off due to, for example, application of a strong lateral slide force on the imitation lawns.

[0007] Especially, with the structure wherein, as shown in FIG. 16 or 17, the periphery of each root portion 100 is tied with a wire piece, and this root portion is internally fitted so

as to be forcibly fitted into a root portion pot 101 with the wire piece, there is a problem that the winding diameters of such wire pieces are not uniform. As a result, where the winding diameter is large (refer to FIG. 16), the root portion pot 101 is caused to be deformed to lead to early deterioration or breakage of a laying board 102 or to the nonuniform planted state of an imitation lawn 103, while where the winding diameter is small (refer to FIG. 17), the imitation lawn is liable to come off the root portion pot 101.

[0008] The present invention has been made in view of the above circumstances, and it is an object of the invention to provide an artificial lawn in which imitation lawns are prevented from coming off a laying board due to influence of temperature on an adhesive, secular deterioration of the adhesive, load of an external force exceeding an adhesive strength, load of a strong lateral slide force, or the like, and a method of manufacturing the artificial lawn.

Means for Solving the Problems

[0009] In order to attain the above object, this invention provides technical means as described below.

[0010] An artificial lawn 1 according to the invention includes imitation lawns 2, and a laying board 3 onto which the imitation lawns are planted, wherein the imitation lawns 2 each include a bunch of foliaceous pieces 4 and a root portion 5 which bundles the bunch of foliaceous pieces, while the laying board 3 includes a plurality of root portion pots 6 into which the root portions 5 of the imitation lawns 2 are forcibly fit, respectively. Further, a bifurcate pin member 7 having two pin tips is driven onto the upper part of the root portion 5 of the imitation lawn 2 forcibly fit in the root portion pot 6 of the laying board 3 such that the pin member traverses a middle part of the root portion, from which the foliaceous pieces 4 are parted, and strides across both sides of an opening of the root portion pot 6. Thus, each imitation lawn 2 is fixed to the laying board 3.

[0011] Owing to the structure in which each imitation lawn 2 and the laying board 3 are physically bonded by the bifurcate pin member 7 in this manner, the bonding strength between the two is high, so that the imitation lawn 2 is prevented from coming off the laying board 3.

[0012] The laying board 3 preferably has a pair of guide grooves 15 (or 35) formed in a peripheral wall part of each root portion pot 6 at positions opposing to each other through the opening of the root portion pot 6 for specifying drive positions of both of the pin tips of the pin member 7. With such guide grooves 15 (or 35), the drive positions of the pin members 7 can be easily unified as predetermined, and a driving operation itself can be easily and reliably performed.

[0013] Both the bifurcate pin tips of the pin member 7 can pierce through a bottom part of the root portion pot 6 in the laying board 3. In this case, the piercing pin tips are preferably bent and folded back. This prevents the pin member 7 from coming off.

[0014] On the other hand, a method of manufacturing an artificial lawn according to the invention includes a method for planting imitation lawns 2, each of which includes a bunch of foliaceous pieces 4 and a root portion 5 bundling the bunch of foliaceous pieces, onto a laying board 3 formed with a plurality of root portion pots 6 into which the root

portions 5 can be forcibly fit, respectively, wherein the root portion 5 of the imitation lawn 2 is forcibly fit into the corresponding root portion pot 6 of the laying board 3, and a pin member 7 (formed in a bifurcate shape having two pin tips) is driven onto an upper part of the root portion 5 such that the pin member traverses a middle part of the root portion, from which the foliaceous pieces 4 are parted, and strides across both sides of an opening of the root portion pot 6.

[0015] Incidentally, the imitation lawns 2 are not limited to the finished lawns in which the root portions 5 are previously formed, but the imitation lawns 2 may be simultaneously fabricated in parallel with planting of the lawns onto the laying board 3. In this case, a lawn strand 23 formed of a large number of fine resin strings 24 bundled and twisted into a shape of a rope is folded in two at an intermediate position in its longitudinal direction; and the fold of the lawn member is forcibly fit into a corresponding root portion pot 6 of a laying board 3. Then, a bifurcate pin member 7 is driven onto a crotch part of the fold from which the lawn strand 23 extending out of the root portion pot 6 is divided into two directions, such that the pin member traverses the crotch part and strides across both sides of an opening of the root portion pot 6. Thereafter, the respective rope strands of the lawn strand 23 extending out of the root portion pot 6 are unfastened, thereby separating the resin strings 24 from each other. By unfastening the rope strands of the lawn strand 23 to separate the resin strings 24 from each other in this manner, the imitation lawn 2 is finished up.

[0016] A method of manufacturing an artificial lawn according to the invention also includes a method as stated below. This method is the same as the above manufacturing method in the operations of folding the lawn strand 23 in two at an intermediate position in its longitudinal direction; forcibly fitting the fold of the lawn strand into a corresponding root portion pot 6 of a laying board 3; and driving a bifurcate pin member 7 onto a crotch part of the fold from which the lawn strand 23 extending out of the root portion pot 6 is divided into two directions, such that the pin member traverses the crotch part and strides across both sides of an opening of the root portion pot 6.

[0017] In this method, one of the lawn stand 23 extending out of the root portion pot 6 is folded at a position the lawn stand reaches an adjacent root portion pot 6; and the folds is forcibly fit into the adjacent root portion pot 6. Then, a bifurcate pin member 7 is driven onto a crotch part of the fold, similarly to the above; and an intermediate part of the lawn strand 23 bridging between the adjacent root portion pots 6 is cut. Thereafter, the respective rope strands of the lawn strand 23 extending out of each of the root portion pots 6 are unfastened, thereby separating the resin strings 24 from each other. With such steps of previously performing the fitting of the lawn strand 23 into the root portion pots 6 and the driving of the pin members 7, and thereafter cutting the lawn strand 23, the operations of fixation and cutting of the lawn strand 23 can be separated and independent of each other, thereby improving efficiency of operations.

[0018] Further, in case of adopting such steps, it is also possible to employ a manner in which a plurality of lawn strands 23 arranged in parallel are simultaneously fed toward the laying board 3, and all the lawn strands 23 are simultaneously forcibly fit into the array of the root portion

pots 6 equal in number to these lawn strands. This further improves efficiency of operations.

ADVANTAGES OF THE INVENTION

[0019] As understood from the above description, in accordance with an artificial lawn and a manufacturing method thereof according to the present invention, imitation lawns are not caused to come off a laying board 3 due to such as influence of temperature on an adhesive, secular deterioration of the adhesive, load of an external force exceeding an adhesive strength, and load of a strong lateral slide force.

BRIEF DESCRIPTION OF THE DRAWINGS

[0020] FIG. 1 is a side sectional view showing a first embodiment of an artificial lawn according to the present invention.

[0021] FIG. 2 is a perspective view corresponding to FIG. 1.

[0022] FIG. 3 is a plan view showing a laying board which is employed in the artificial lawn of the first embodiment.

[0023] FIG. 4 is a perspective view showing a lawn strand which is employed in the artificial lawn of the first embodiment.

[0024] FIG. 5 is an enlarged sectional view taken along line A-A indicated in FIG. 1.

[0025] FIG. 6 is a side sectional view showing a state where a pin member has been driven in a process for manufacturing the artificial lawn of the first embodiment.

[0026] FIG. 7 is a view seen in the direction of line B-B indicated in FIG. 6.

[0027] FIG. 8 is a side sectional view showing a state where the pin member is in the course of being driven in the process for manufacturing the artificial lawn of the first embodiment.

[0028] FIG. 9 is a perspective view showing a laying board which is employed in a second embodiment of the artificial lawn according to the invention.

[0029] FIG. 10 is a perspective view showing a process for manufacturing the artificial lawn of the second embodiment.

[0030] FIG. 11 is a perspective view showing another example of an imitation lawn.

[0031] FIG. 12 is a sectional perspective view showing an example in which openings are provided in the bottom part of a root portion pot.

[0032] FIG. 13 is a plan view corresponding to FIG. 12.

[0033] FIG. 14 is a side sectional view showing a state where a pin member has been driven into the root portion pot in FIG. 12 (a lawn member is not shown).

[0034] FIG. 15 is a perspective view illustrating a process flow in another embodiment of an artificial lawn manufacturing method according to the invention.

[0035] FIG. 16 is a side sectional view showing an example of a disadvantage in a prior-art artificial lawn.

[0036] FIG. 17 is a side sectional view showing another example of a disadvantage in the prior-art artificial lawn.

DESCRIPTION OF REFERENCE NUMERALS

- [0037] 1 artificial lawn
- [0038] 2 imitation lawn
- [0039] 3 laying board
- [0040] 4 foliaceous piece
- [0041] 5 root portion
- [0042] 6 root portion pot
- [0043] 7 pin member
- [0044] 15 guide groove
- [0045] 23 lawn strand
- [0046] 24 string
- [0047] 35 guide groove

BEST MODE FOR CARRYING OUT THE INVENTION

[0048] Embodiments of the present invention will now be described with reference to the drawings.

[0049] FIGS. 1 through 8 show a first embodiment of an artificial lawn 1 according to the invention. The artificial lawn 1 includes imitation lawns 2, and a laying board 3 for planting the imitation lawns 2 thereonto. The imitation lawns 2 each include a bunch of foliaceous pieces 4 and a root portion 5 which bundles the bunch of foliaceous pieces. The laying board 3 has a plurality of root portion pots 6 so that the imitation lawns 2 can be allocated and arranged at predetermined mutual intervals between each bundle of foliaceous pieces (root portion 5). Each of the imitation lawns 2 is fixed to the laying board 3 by a pin member 7 which has a bifurcate shape including two pin tips.

[0050] The laying board 3 is formed of flexible or hard plastics, rubber, or the like. The shape and size of the whole laying board 3 as viewed in plan are not limited at all. For example, the whole laying board 3 may be in a square or oblong shape of several tens centimeters in length and width, or in a circular shape or any other shape, and it may be enlarged or lengthened into the size of a "tatami" mat or the shape of a sheet.

[0051] In the illustrated laying board 3, the root portion pots 6 are vertically and laterally arranged in an orderly manner through convex blocks 8 each of which is square in plan view. The convex blocks 8 serve to arrange the root portion pots 6 at predetermined mutual intervals in the orderly manner, and also serve to endow the laying board 3 with a predetermined rigidity by making the side sectional shape thereof uneven. Further, a plurality of (four) openings 9 each being substantially triangular are formed in the upper surface of each convex block 8, and oblong penetrating ports 10 are provided between the respectively adjacent ones of the convex blocks 8, so that a water permeability is ensured for the laying board 3 by the openings and ports.

[0052] The root portion pot 6 is formed as a leg portion 11 in the shape of a bottomed cup protruding on the lower surface side of the laying board 3 oppositely to the convex

block 8, and having the interior formed as an upwardly open cavity. The lower end surface of the leg portion 11 is a ground-touching surface, and a drainage space can be ensured under the laying board 3 in correspondence with the height of the cup shape. A rib 12 is provided at the outer periphery of the lower end surface of the leg portion 11, and the bottom part of the root portion pot 6 is formed as a raised bottom. That is, a raised bottom space 13 is defined inside the rib 12. Further, the peripheral wall part of the root portion pot 6 is formed with a pair of two guide grooves 15 which extend in the depth direction of the root portion pot 6 on both sides (at opposite positions) astride the opening of this root portion pot 6. The guide grooves 15 are open to the opening side of the root portion pot 6. Incidentally, notwithstanding that the bottom of the root portion pot 6 is closed, the guide grooves 15 may be open on the bottom side of this root portion pot 6 (refer to FIGS. 12 through 14 to be stated later).

[0053] The root portion 5 of the imitation lawn 2 is forcibly fit into the root portion pot 6, and the bifurcate pin member 7 is driven so as to traverse the upper middle part of the root portion 5, namely, the middle part of the bundle of foliaceous pieces 4 from which the foliaceous pieces are parted. In this position, the pin member 7 strides across both sides of the opening portion of the root portion pot 6 with both pin tips thereof penetrating through the bottom part of the root portion pot 6.

[0054] The guide grooves 15 provided in the root portion pot 6 are usable for specifying the drive positions of both pin tips, in driving the pin member 7 in this manner, and they are also advantageous for guiding both the pin tips, in driving the pin member 7. Further, the bottom space 13 is provided under the bottom part of the root portion pot 6 so that, when the pin member 7 has been driven into the bottom part of the root portion pot 6 and has penetrated through this bottom part, the penetrating pin tips can be bent and accommodated without interfering with the grounding of the leg portion 11.

[0055] A staple in the shape of letter U having a rectilinear bottom part is employed as the pin member 7. The pin member 7 in such a shape is driven with a tool 19 in which, as shown in FIGS. 6 and 8, the pin member 7 loaded in a striking guide 17 is knocked in from the rear side thereof by a hammer 18 with a pneumatic pressure, an electric operation, or a manual lever operation, so as to be struck via the striking guide 17.

[0056] The imitation lawn 2 is formed of a rope-like lawn strand 23 as shown in FIG. 4. The lawn strand 23 is formed of a large number of strings 24 bundled and twisted. In the illustrated example, a relatively small number of strings 24 are once twisted as a lawn strand of small diameter 25, and a plurality of (three) such lawn strands 25 are thereafter twisted up, thereby forming the lawn strand of large diameter 23 to increase the number of the used strings 24. The string 24 is formed of a resin having high flexibility and elasticity (shape restorability), and formed in a flat, circular, or the like shape in section which is as fine as a leaf of a genuine lawn. Each string 24 may be endowed with a coiling tendency.

[0057] The lawn strand 23 is folded in two in its longitudinal direction, the folds are forcibly fit into the root portion pot 6 of the laying board 3, and the rope strands of the lawn strand 23 are respectively unfastened at portions extending

out of the root portion pot 6 in the state where the folds are fit in the root portion pot, whereby the strings 24 are separated from each other. That is, the portion fit into the root portion pot 6 corresponds to the root portion 5 of the imitation lawn 2, and the strings 24 in the separated state correspond to the foliaceous pieces 4, respectively.

[0058] In order to manufacture such an artificial lawn 1 of the first embodiment, first of all, the lawn strand 23 is cut into a suitable length, the cut lawn strand 23 is folded in two at an intermediate position in its longitudinal direction, and the fold is forcibly fit into the corresponding root portion pot 6 of the laying board 3.

[0059] After the fold of the lawn strand 23 has been thus fit into the root portion pot 6, the lawn strand 23 extending out of the root portion pot 6 is divided into two directions at a crotch of the fold as shown in FIGS. 5 and 7, and the striking guide 17 of the tool 19 is brought into contact with the upper portion of the crotch of the fold as shown in FIG. 8. Further, a position at which the pin member 7 in the striking guide 17 is driven is adjusted with respect to the both side guide grooves 15 provided in the root portion pot 6.

[0060] In this state, a pin bending die 30 is held on the opposite side to the striking guide 17 with respect to the bottom part of the root portion pot 6 so as to correspond to positions at which the pin member 7 is expected to penetrate through the bottom part. The die 30 is configured to fit in the bottom space 13 provided under the bottom part of the root portion pot 6, thereby advantageously facilitating the positioning between the laying board 3 and the die 30, and preventing any positional deviation.

[0061] In such a state, the striking guide 17 and the die 30 are caused to press (sandwichingly hold) the bottom part of the root portion pot 6 intensely from opposite sides, and then, the tool 19 is actuated to knock the rear side of the pin member 7 with the hammer 18 so as to strike out the pin member 7. Thus, the pin member 7 struck out of the striking guide 17 sticks its both side pin tips into the bottom part of the root portion pot 6 while extending over the upper portion of the crotch of the fold of the lawn strand 23, and penetrates through the bottom part from the state of FIG. 8 to the state of FIG. 6. Further, the pin tips of the pin member 7 are bent and folded back by the die 30, whereby the pin member 7 is prevented from coming off.

[0062] When the tool 19 is detached in this state, the crotch of the lawn strand 23 extending out of the root portion pot 6 in two directions as shown in FIG. 5 is fixed to the laying board 3 by the pin member 7. Subsequently, the rope strands of the lawn strand 23 extending out in the two directions are respectively unfastened, thereby separating the strings 24 from each other. Thereafter, the strings 24 are appropriately cut into a uniform length, thereby finishing up the imitation lawn 2 in which the fold fixed by the pin member 7 corresponds to the root portion 5 of the imitation lawn 2, and the parts of the strings separated above the root portion correspond to the foliaceous pieces 4 of the imitation lawn 2.

[0063] In the finished state, the pin member 7 is positioned with respect to the imitation lawn 2 such that the pin member traverses the middle part of the root portion 5 in the imitation lawn 2. Further, the pin member 7 is positioned with respect

to the laying board 3 such that the pin member strides across both sides of the opening of the root portion pot 6.

[0064] FIGS. 9 and 10 show a laying board 3 of different shape as a second embodiment of the artificial lawn 1 according to the invention. The laying board 3 used in the second embodiment includes arrays X in each of which root portion pots 6 and recesses 33 generated by forming leg portions are alternately arranged and aligned, and arrays Y in each of which water-permeable openings 34 are aligned, and the arrays X and Y are disposed to be alternately repeated in a direction orthogonal to the direction of the arrays.

[0065] The root portion pot 6 forms a leg portion 11 which protrudes in the shape of a bottomed cup on the lower surface side of the laying board 3, the lower end surface of the leg portion 11 serves as a ground-touching surface of the laying board 3, and a drainage space is ensured under the laying board 3 in correspondence with the height of the cup shape. The peripheral wall part of the root portion pot 6 is provided with a pair of two guide grooves 35 extending in the depth direction of the root portion pot 6 and disposed on both sides (at opposite positions) astride the opening of this root portion pot 6. The guide grooves 35 are usable for specifying the drive positions of both the pin tips of a pin member 7, when driving the pin member 7. However, unlike the guide members 15 described in the first embodiment, the guide grooves 35 in the second embodiment do not guide the pin member 7 itself, but they guide the insertion of a striking guide 17 of a tool 19 which is used for driving the pin member 7, in such a manner that these guide grooves permit the striking guide to snugly fit therein without rattling.

[0066] As stated above, the recess 33 is generated by forming the leg portion protruding on the lower surface side of the laying board 3, but this leg portion is different from the leg portion 11 serving also as the root portion pot 6. In the illustrated example, an opening having X shape in plan view is provided, but the opening may be in any shape such as a circle or a rectangle.

[0067] An imitation lawn 2 and the pin member 7 used in this embodiment are the same as those in the first embodiment. Therefore, a method of manufacturing an artificial lawn 1 by employing the laying board 3 as stated above is substantially the same as in the first embodiment except that, when driving the pin member 7, the striking guide 17 of the tool 19 is inserted into the guide grooves 35 provided in the root portion pot 6 so as to drive the pin member 7.

[0068] Meanwhile, the pin member 7 to be employed may be in the shape of letter U having a curvilinear bottom part other than the shape of letter U having a rectilinear bottom part. It is also possible to employ the pin member 7 which does not pierce through the bottom part of the root portion pot 6. In this case, the die 30 is not necessary, and the pin member 7 is merely driven (without bending the pin tips).

[0069] It is also possible to previously apply an adhesive on the lawn strand 23 or the interior of the root portion pot 6 before the folds of the lawn strand 23 are forcibly fit into the root portion pot 6 of the laying board 3 so as to conjointly use the adhesive and the pin member 7 for the fixation between the laying board 3 and the imitation lawn 2, whereby the bonding strength between the laying board 3 and the imitation lawn 2 is synergetically increased more effectively.

[0070] Further, the imitation lawn 2 is not limited to the one which is formed in parallel with the planting onto the laying board 3, but a previously finished one which includes foliaceous pieces 4 and a root portion 5 in one complete shape as shown in FIG. 11 may be used. In this case, the root portion 5 of an imitation lawn 2 is formed by tying the foliaceous pieces 4 at a position adjacent to the root portion with a tying member 40 such as a wire piece, a binding yarn, or the like, or by filling and hardening the root portion with an adhesive, a melted resin, a rubber or the like.

[0071] In order to manufacture an artificial lawn 1 with thus previously finished imitation lawn 2, the root portion 5 of the imitation lawn 2 is forcibly fit into the root portion pot 6 of a laying board 3, the foliaceous pieces 4 are parted so as to expose substantially the middle part of the root portion 5, and a bifurcate pin member 7 is driven with a tool 19 set on the exposed part. Thus, the pin member is positioned such that the pin member 7 traverses the middle part of the root portion 5 with respect to the imitation lawn 2, while the pin member 7 strides across both sides of the opening of the root portion pot 6 with respect to the laying board 3.

[0072] As shown in FIGS. 12 through 14, openings 50 communicating with guide grooves 15 may be formed in the bottom part of a root portion pot 6 beforehand. The formation of such openings 50 allows easy, prompt and reliable driving of a pin member 7 and bending of the pin tips thereof.

[0073] Regarding the manufacturing method in which the imitation lawn 2 is formed by forcibly fitting the fold of the lawn strand 23 into the root portion pot 6 of the laying board 3, the following steps may also be adopted. As shown in FIG. 15, the lawn strand 23 is folded in two at an intermediate position in its longitudinal direction, the fold is forcibly fit into the predetermined root portion pot 6 of the laying board 3, and the pin member 7 is thereafter struck onto the crotch of the fold (refer to sign X). Further, one of the lawn strand 23 extending out of the root portion pot 6 is folded in two at a position the lawn strand reaches an adjacent root portion pot 6, and the resulting fold is forcibly fit into the adjacent root portion pot 6 (refer to sign Y).

[0074] Incidentally, it is advantageous to provide a claw 52 for suspending the lawn strand 23 at a predetermined height between the adjacent root portion pots 6 so as to facilitate setting of the length of the lawn strand 23 and accurately unify the lengths thereof in the following repeated operations. Further, in order to set the length of the lawn strand 23, the feed position of the lawn strand 23 may be moved between the adjacent root portion pots 6 with the laying board 3 held stopped, or conversely, the laying board 3 may be moved in conformity with the pitch of the adjacent root portion pots 6 with the feed position of the lawn strand 23 held stopped.

[0075] After the fold of the lawn strand 23 is forcibly fit into the adjacent root portion pot 6 in this manner, the pin member 7 is struck onto a crotch of the fold with the tool 19, similarly to the above.

[0076] Subsequently, the lawn strand 23 bridging between the adjacent root portion pots 6 is cut at an intermediate position thereof (refer to sign Z) Then, the rope strands of the lawn strand 23 extending out of each root portion pot 6 are respectively unfastened so as to separate the resin strings

24 from each other. According to these steps, it is possible to previously perform the forcible fitting of the lawn strand 23 into the root portion pots 6 and the striking of the pin members 7, and thereafter perform the operations of cutting the lawn strand 23 collectively. Therefore, the efficiency of the job can be improved.

[0077] Further, in case of adopting such steps, it is also possible to employ a manner in which a plurality of lawn strands 23 arranged in parallel are simultaneously fed toward the laying board 3, and all the lawn strands 23 are simultaneously forcibly fit into the array of the root portion pots 6 equal in number to these lawn strands. This further improves efficiency of operations.

[0078] It should be noted that the present invention is not limited to the embodiments described above, but various modifications can be made in accordance with conditions under which the invention is embodied.

INDUSTRIAL APPLICABILITY

[0079] The artificial lawn of the present invention can be laid on a porch, a housetop, a road, a poolside, or the like.

1. An artificial lawn characterized by comprising imitation lawns (2), and a laying board (3) onto which said imitation lawns are planted, said imitation lawns (2) each including a bunch of foliaceous pieces (4) and a root portion (5) which bundles the bunch of foliaceous pieces, said laying board (3) including a plurality of root portion pots (6) into which said root portions (5) of said imitation lawns (2) are forcibly fit, respectively, said each imitation lawn (2) being fixed to said laying board (3) by driving a bifurcate pin member (7) having two pin tips onto an upper part of the root portion (5) of said imitation lawn (2) forcibly fit in the root portion pot (6) of said laying board (3), such that said pin member traverses a middle part of the root portion, from which said foliaceous pieces (4) are parted, and strides across both sides of an opening of said root portion pot (6).

2. An artificial lawn as set forth in claim 1, characterized in that said laying board (3) has a pair of guide grooves (15) or (35) for specifying drive positions of both the pin tips of said pin member (7), the guide grooves being formed in a peripheral wall part of said each root portion pot (6) at positions opposing to each other through the opening of said root portion pot (6).

3. An artificial lawn as set forth in claim 1, characterized in that both the pin tips of said pin member (7) pierce through a bottom part of said root portion pot (6) of said laying board (3) and are folded back.

4. A method of manufacturing an artificial lawn (1), wherein imitation lawns (2), each of which includes a bunch of foliaceous pieces (4) and a root portion (5) bundling the bunch of foliaceous pieces, are planted onto a laying board (3) formed with a plurality of root portion pots (6) capable of receiving the root portions, respectively,

the method being characterized in that the artificial lawn is manufactured by: forcibly fitting the root portion (5) of the imitation lawn (2) into the corresponding root portion pot (6) of said laying board (3); driving a bifurcate pin member (7) having two pin tips onto an upper part of said root portion (5) such that said pin member traverses a middle part of the root portion,

from which said foliaceous pieces (4) are parted, and strides across both sides of an opening of said root portion pot (6).

5. A method of manufacturing an artificial lawn, characterized by comprising steps of: folding a lawn strand (23) in two at an intermediate position in its longitudinal direction, the lawn strand comprising a large number of fine resin strings (24) bundled and twisted into a shape of a rope; forcibly fitting the fold of the lawn strand (23) into a predetermined one of root portion pots (6) of a laying board (3) formed with a plurality of root portion pots (6) capable of receiving the folds; driving a bifurcate pin member (7) having two pin tips onto a crotch part of the fold from which the lawn strand (23) extending out of the root portion pot (6) is divided into two directions, such that the pin member traverses the crotch part and strides across both sides of an opening of the root portion pot (6); and thereafter unfastening the respective rope strands of the lawn strand (23) extending out of the root portion pot (6), thereby separating the resin strings (24) from each other.

6. A method of manufacturing an artificial lawn, characterized by comprising steps of: folding a lawn strand (23) in two at an intermediate position in its longitudinal direction, the lawn strand (23) comprising a large number of fine resin strings (24) bundled and twisted into a shape of a rope;

forcibly fitting the fold of the lawn strand (23) into a predetermined one of root portion pots (6) of a laying board (3) formed with a plurality of root portion pots (6) capable of receiving the folds; driving a bifurcate pin member (7) having two pin tips onto a crotch part of the fold from which the lawn strand (23) extending out of the root portion pot (6) is divided into two directions, such that the pin member traverses the crotch part and strides across both sides of an opening of the root portion pot (6); folding one of the lawn strand (23) extending out of the root portion pot (6) at a position the lawn strand reaches an adjacent root portion pot (6); forcibly fitting the fold of the lawn strand (23) into the adjacent root portion pot (6); driving a bifurcate pin member (7) onto a crotch part of the fold, similarly to the above; cutting an intermediate part of the lawn strand (23) bridging between the adjacent root portion pots (6); and thereafter unfastening the respective rope strands of the lawn strand (23) extending out of each of the root portion pots (6), thereby separating the resin strings (24) from each other.

7. An artificial lawn as set forth in claim 2, characterized in that both the pin tips of said pin member (7) pierce through a bottom part of said root portion pot (6) of said laying board (3) and are folded back.

* * * * *