

Oct. 25, 1949.

H. GILBERT
STOCKING INSPECTION DEVICE HAVING ILLUMINATING
AND MAGNIFYING MEANS

2,485,820

Filed Dec. 29, 1945

2 Sheets-Sheet 1

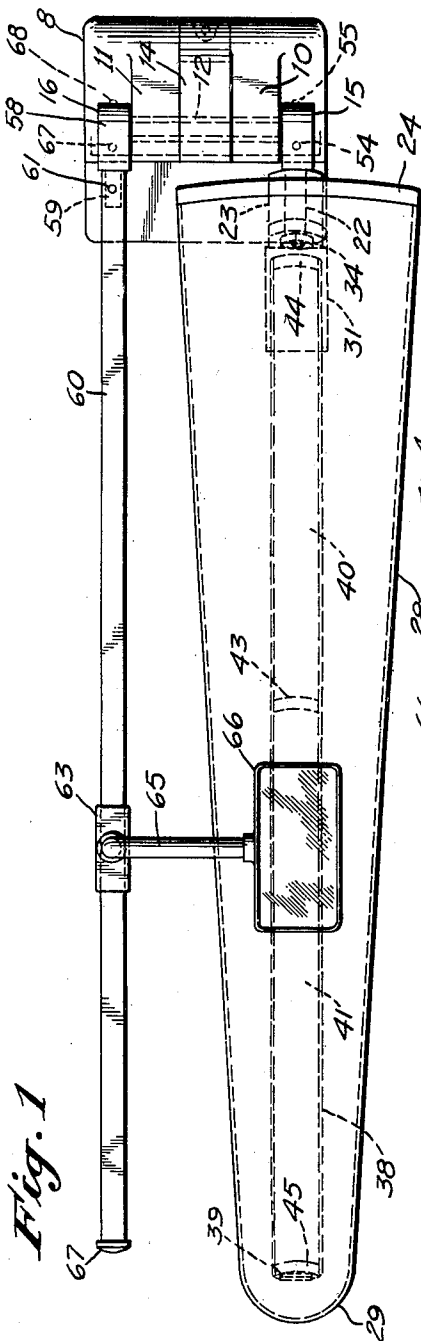

Fig. 1

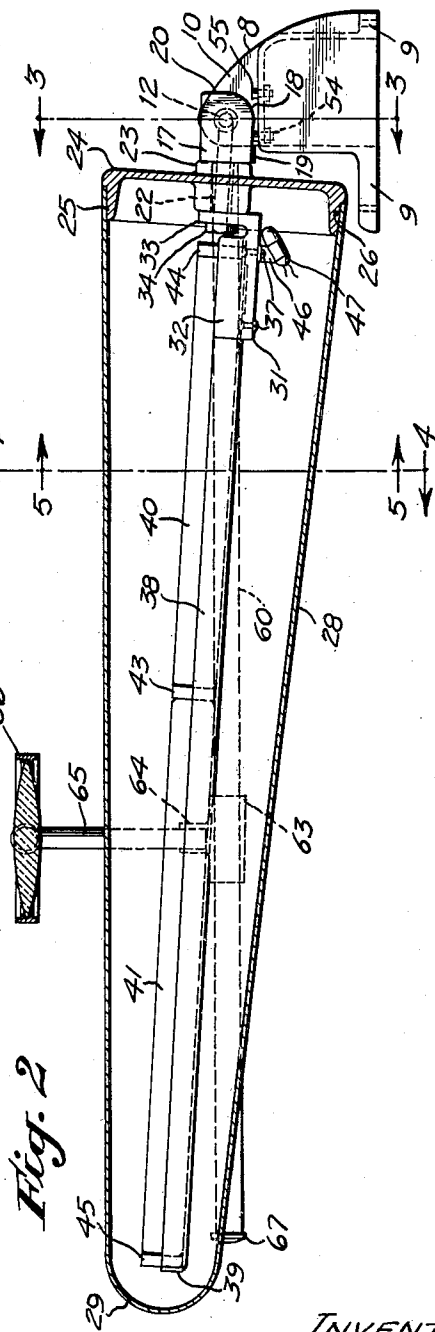

Fig. 2

INVENTOR
HENRY GILBERT
By HARRIS, KIECH, FOSTER & HARRIS
[Signature]
FOR THE FIRM
ATTORNEYS

Oct. 25, 1949.

H. GILBERT
STOCKING INSPECTION DEVICE HAVING ILLUMINATING
AND MAGNIFYING MEANS

2,485,820

Filed Dec. 29, 1945

2 Sheets-Sheet 2

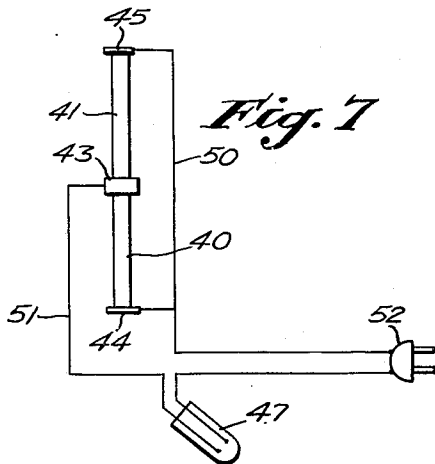
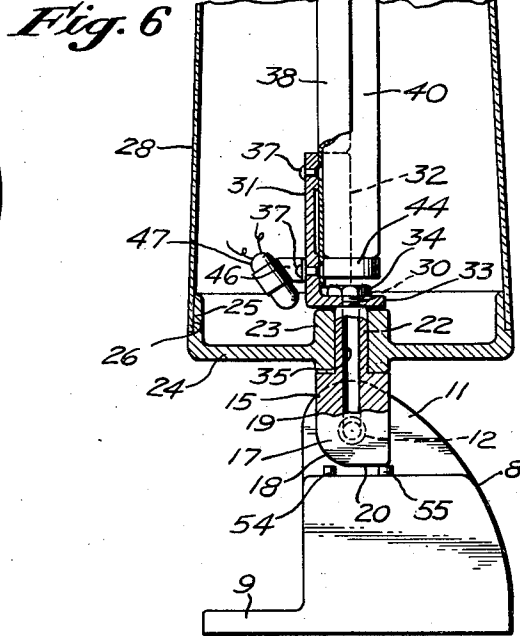
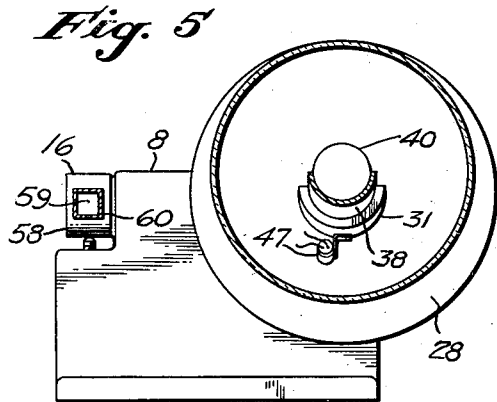
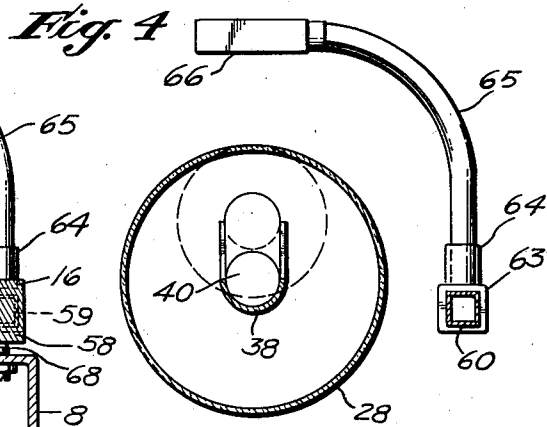
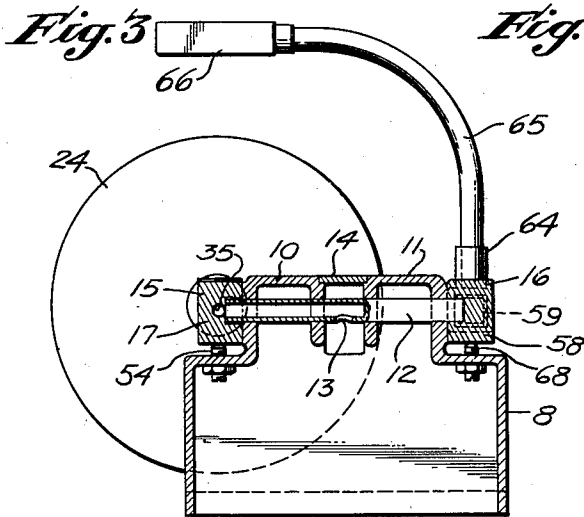

INVENTOR
HENRY GILBERT
By HARRIS, KIECH, FOSTER & HARRIS
Lawrence W. Harris
FOR THE FIRM
ATTORNEYS

UNITED STATES PATENT OFFICE

2,485,820

STOCKING INSPECTION DEVICE HAVING ILLUMINATING AND MAGNIFYING MEANS

Henry Gilbert, North Hollywood, Calif., assignor,
by mesne assignments, to Gotham Hosiery
Company, Inc., New York, N. Y., a corporation
of Delaware

Application December 29, 1945, Serial No. 638,255

7 Claims. (Cl. 88—14)

1

2

This invention relates generally to textile inspecting apparatus for assisting in the inspection of various textile materials and particularly to a device for facilitating the inspection of hosiery.

It is a well established fact that hosiery made from delicate silk, rayon and nylon threads are subject to imperfections which sometimes occur during their manufacture or when later subjected to rough handling by sales personnel or a wearer of the hosiery. After hosiery has been knit and processed it is usually inspected at the mill to determine the quality thereof, hosiery having slight imperfections being segregated from those of perfect quality and labeled "irregulars." The first quality hosiery is usually guaranteed by the mill and retail store to withstand ordinary wear when properly laundered and cared for by the purchaser. If often happens that the customers fail to follow the laundering instructions and other suggestions made by the manufacturer and fail to exercise proper care of the hosiery, with the result that small holes, "runs," and other imperfections occur in the delicately knit fabric. Such damaged hosiery is often returned to the store for replacement and it becomes necessary for the store personnel to first determine the extent and apparent cause of such damage to aid them in deciding whether or not such hosiery should be replaced in accordance with the manufacturer's guarantee.

While various inspection devices are employed in the mill, no such means are used in the stores, it being the usual practice to slide the hosiery over a hand to inspect the damaged portion. It is generally conceded that this method of inspecting hosiery is inefficient since it is impossible to positively determine whether "runs" or holes are due to the improper looping of the threads during the knitting operation or to breaking of the individual filaments of the hosiery by the wearer.

It is the primary object of my invention to provide a textile inspecting device, especially adapted for use in retail stores, for facilitating inspection of hosiery to determine the extent of and aid in establishing the cause of imperfections in such hosiery.

Another object is to provide a device of the type indicated comprising a rotatable light-permeous hosiery form or support upon which a stocking may be slid, a light source within the support for illuminating the stocking, and a magnifying lens movable along the length of the

support to enlarge the filaments of the stocking fabric and permit them to be inspected.

Another object is to provide a device of the type indicated which may be fastened to a sales counter or the like or made as a portable unit capable of being moved to any desired location.

Another object is to provide a device of the type indicated in which the rotatable stocking support is pivotally mounted on a base to adapt it to be tilted upwardly to vertical position, thereby permitting the use of substantially the entire area of the sales counter when the apparatus is not in use.

Another object is to provide a device of the type indicated having a conical stocking form or support which is rotatable on an axis inclined with respect to the horizontal to position the upper portion of its periphery in a horizontal plane parallel to the sales counter or table, and means for moving the magnifying lens parallel to and at a desired distance from the upper portion of the support.

Another object is to provide a device of the type indicated in which the electrical circuit for the light source is controlled by a mercury switch movable with the pivoted stocking support and operative, when the support is moved to operative position, to close the circuit to the light source and to open the circuit when the stocking support is moved to inoperative position.

Further objects and advantages of the invention will appear from the following specification and drawings which are for the purpose of illustration only, and in which:

Fig. 1 is a plan view of a hosiery inspection device constructed in accordance with my invention;

Fig. 2 is a side elevational view of the device with the hosiery support shown in section to illustrate the interior parts;

Fig. 3 is an enlarged cross-sectional view of the device taken on line 3—3 of Fig. 2, showing the pivotal mounting of the hosiery support and magnifying lens;

Fig. 4 is an enlarged cross-sectional view of the device taken on the line 4—4 of Fig. 2, showing the mounting for the electric illuminating means;

Fig. 5 is an enlarged cross-sectional view of the device taken on line 5—5 of Fig. 2, illustrating the construction at the pivotal end thereof;

Fig. 6 is an enlarged longitudinal view of the pivotal end of the device, shown part-sectional to illustrate parts of the device in detail; and

Fig. 7 is a diagram of the electrical circuit for the illuminating means.

3

The hosiery inspection device comprises, in general, a base member adapted to be placed on a sales counter or other flat surface; a spindle pivotally mounted on said base member and rotatably mounting a hollow conical translucent hosiery support member, said support member being adapted to support a stocking; electric illuminating means within the support member and adapted to illuminate said support member to cause the reticulated hosiery fabric to be silhouetted thereagainst; a slide pivotally mounted on said base member; and a magnifying lens movable along said slide to enlarge the silhouetted filaments of the hosiery fabric, said lens being movable in a path parallel to the side of said support member.

Referring to the drawings, the hosiery inspection device comprises a base member 8, constructed in the form of an inverted box-like casting and having projecting pads or feet 9 which may be suitably fastened to a table or the top of a sales counter. The base member 8 has spaced upstanding bearing ears 10 and 11 which are bored with aligned laterally-extending holes for receiving a tubular pivot shaft 12 provided with a central radial hole 13. The space between the bearing ears 10 and 11 is closed by a sheet-metal cover 14 which may also serve as a name-plate. The ends of the pivot shaft 12 project outwardly beyond the bearing ears 10 and 11 and are forced into or otherwise held in suitable holes in a spindle member 15 and a slide mounting 16, see Figs. 1 and 3.

The spindle member 15 consists of a rectangular body portion 17 having its lower rearward corner 18 rounded as shown in Figs. 2 and 6 and provided with stop faces 19 and 20 for a purpose to be later explained. Projecting from the body portion 17 of the spindle member 15 is a cylindrical spindle 22 for rotatably mounting the hub 23 of a circular plate-like member 24. The member 24 has a peripheral conical rim 25 which is recessed at 26 to adapt it to be received in the open end of a stocking support member 28 and to be secured thereto in any suitable manner. The stocking support member 28, which is preferably constructed from translucent plastic material, has its tip end or vertex closed by a semi-spherical portion 29.

The spindle 22 is provided with a reduced externally threaded extension 30 upon which is carried a mounting frame member 31. As shown in Fig. 5, the frame member 31 comprises a semi-circular channel portion 32 having an upstanding end wall 33 (Fig. 6) provided with a hole to adapt it to be mounted on the threaded extension 30 of the spindle 22. As shown in Fig. 6, a nut 34 is threaded on the projecting end of the extension 30 and set up against the end wall 33 to clamp the frame member 31 tightly against the shoulder formed between the spindle 22 and its extension. It will thus be apparent that the frame member 31 is fixedly mounted on the spindle member 15 while the plate member 24 and stocking support 28 are freely rotatable on the spindle 22. The spindle member 15 is provided with a longitudinal bore 35 for a purpose to be later explained.

Secured within the semi-circular portion 32 of the frame member 31 by means of rivets 37 is a sheet-metal reflector member 38 of semi-circular cross section, see Figs. 4 and 5. The member 38 extends longitudinally from the frame member 31 throughout substantially the entire length of the stocking support 28 and is provided at its outer end with an abutment 39. A pair of fluorescent tubes

4

40 and 41 are placed in the reflector member 38 which is made resilient to retain them in position. A double socket 43 is arranged between the abutting ends of the tubes 40 and 41 and the tubes have sockets 44 and 45 respectively, the socket 45 being positioned against the abutment 39. Held in a clip 46 fastened to the under side of the frame member 31 is an electric switch 47 comprising a glass bulb containing a pool of mercury which is adapted to flow longitudinally therein when the stocking support 28 is pivoted on the base member 8.

The electric bulbs or tubes 40 and 41 and the mercury type switch 47 are connected in an electrical circuit in the manner indicated in the electrical diagram (Fig. 7). As shown in the diagram, one lead 50 is connected to the endmost sockets 44 and 45 while the other lead 51 is joined to the central double socket 43. The mercury switch 47 may be connected in the lead 51 to control the lighting of the tubes 40 and 41. The leads 50 and 51 are preferably connected to a plug member 52 which may be inserted into any electric outlet receptacle. The lines 50 and 51 preferably extend upwardly through the open bottom of the base member 8 and pass through the hole 13 to the interior of the tubular pivot shaft 12, thence through the bore 35 of the spindle member 15 from which point the lines lead to the mercury switch 47 and the various sockets of the tubes 40 and 41 to be connected thereto.

The axis of the hosiery support 28 is inclined upwardly slightly from the pivot shaft 12 as shown in Fig. 2 when the device is applied to use whereby to adapt the upper portion of its periphery to extend horizontally. A set-screw 54 adjustably screwed into the top surface of the base member 8 serves as a stop against which the face 19 of the spindle member 15 rests to maintain the hosiery support 28 in the desired position. A second stop screw 55 projecting upwardly from the base member 8 is engaged by the face 20 of the spindle member 15 to limit the upward pivotal movement of the hosiery support 28 to inoperative position.

The slide mounting member 16, previously described as connected to one end of the pivot shaft 12, has a body portion 58, similar in outline to the body portion 17 of the spindle member 15. The body portion 58 is joined to the pivot shaft and is provided with a forwardly projecting stem 59 of square cross section, see Figs. 1 and 3. A square tube 60 of substantially the same length as the hosiery support 28 is connected to the stem 59 by sliding its end thereon and securing it in place by a pin 61 as shown in Fig. 1. The square tube 60 serves as a guide member along which a slide member or holder 63 is adapted to be moved. The holder 63 has a square hole for receiving the slide tube 60 and an upwardly projecting boss 64 which is provided with a vertical hole for receiving the lower end of a rod 65. As shown in Figs. 3 and 4, the rod 65 extends upwardly from the slide member or holder 63 and curves laterally to overlie the hosiery support 28. A rectangular magnifying lens 66 is carried at the end of the laterally extending portion of the rod 65. An abutment 67 is provided at the free end of the guide member 60 to prevent displacement of the holder 63 and lens 66 from the tube.

It will be noted from the drawings that the guide member 60 extends horizontally from the pivot shaft 12 so that when the holder 63 is slid therealong the magnifying lens 66 is moved in a path parallel to the upper surface of the conical

5

hosiery support 28 and thus it is unnecessary to adjust the lens vertically to maintain it at a uniform distance from the top of the support. Since the member 16 is carried by the pivot shaft 12 the guide member 60 will be maintained in horizontal position by the stop-screw 54. However, to provide additional support a similar stop-screw 67 on the base member 8 may be engaged by the lower face of the member 16 and a stop-screw 68 may be engaged by the rearward face of the member 16 when the guide member 60 pivots upwardly with the hosiery support 28.

The hosiery inspection device is applied to use in the manner next explained. Assuming that the parts of the device are in the position shown in Fig. 2, electric current will flow through the pool of mercury of the switch 47 to bridge the contacts of said switch to thereby supply current to the fluorescent tubes 40 and 41. A stocking, not shown, may be slid onto the translucent hosiery support 28 and light will be directed upwardly by the reflector member 38 to illuminate the filaments of the meshed fabric. Since the knitted fabric is silhouetted against an illuminated surface the individual filaments and loops of the fabric may be readily observed and inspected. To further facilitate the inspection of the stocking fabric the magnifying lens 66 may be slid longitudinally of the support 28 and the magnified fabric view therethrough. By alternately rotating the hosiery support 28 on its spindle 22 and moving the lens 66 longitudinally, the entire stocking may be quickly and thoroughly inspected and holes, "runs," and other imperfections easily detected and examined.

When the inspection device is not in use the hosiery support 28, together with the guide member 60 and lens 66 may be pivoted upwardly to substantially vertical position as shown in Fig. 6. As the support 28 approaches a vertical position the face 20 of the spindle member 15 and a similar face of the mounting member 16 will strike the upper ends of the stop-screws 55 and 68 respectively to limit movement of the parts in this direction. During the upward movement of the parts the pool of mercury in the switch 47 will flow away from the switch contacts to open the electrical circuit and thus extinguish the light tubes 40 and 41.

It will be observed from the foregoing that the present invention provides a novel and ingenious device for facilitating the inspection of textile fabrics and especially reticulated hosiery fabric. The device is especially adapted for use on the sales counters of stores and serves the useful function of aiding the salesperson in determining the extent of imperfections present in the stockings. Since the device eliminates guesswork, the apparent cause of such damage can be readily ascertained, and such evidence may be considered a deciding factor in determining whether or not the damaged hosiery should be replaced by the manufacturer or store. Thus, the use of this device effects a substantial saving to the mill and retailer. Since the customer may also inspect the stockings on the device at the counter she will usually agree with the decision of the salesperson and thus the good will of the customer will be maintained.

The inspection device is simple in construction, being composed of few parts which may be easily and quickly assembled thus rendering the device economical to manufacture. Moreover, the device is provided with a rotatable conical hosiery support upon which stockings of various sizes may be

6

held and turned with the support to facilitate their inspection. The translucent stocking support is illuminated so that the outline of the individual loops of the reticulated fabric may be readily observed. To further aid in the inspection, the present device utilizes a magnifying lens for enlarging the fabric and the lens is movable along the stocking to hasten the inspection process. As a particular feature of improvement, the stocking support and magnifying means are pivoted in a manner to permit them to be tilted upwardly as a unit when the device is not in use. As another feature, means actuated by the pivotal movement of the stocking support is provided for controlling the lighting of the support so that when the parts are moved to inoperative position the lights will be automatically extinguished. Furthermore, the invention provides means for moving the magnifying lens in a path parallel to the side of the conical stocking support so that the need for adjusting the lens to follow the contour of the support is eliminated.

While the hosiery inspection device has been herein shown and described as embodied in a preferred form of construction, by way of example, it is to be understood that various modifications may be made thereto without departing from the spirit or scope of the invention.

I claim as my invention:

1. A device for facilitating inspection of hosiery, comprising: a base member; a pivot shaft rotatable on said base member; a spindle carried by said pivot shaft; a hollow translucent conical support member coaxial with and rotatable on said spindle and adapted to support a stocking; inter-engaging means on said base member and said spindle adapted to releasably retain said spindle in a position extending laterally from said base member and inclined at an angle disposing the upper surface of said support member horizontally; electric fluorescent tubes within said support member for illuminating said support member to cause the filaments of said stocking to be silhouetted thereagainst; a guide member carried by said pivot shaft; and optical magnifying means movable along said guide member and through which the filaments of said stocking can be viewed, said guide member normally extending horizontally from said pivot shaft to adapt said magnifying means to move in a path parallel to said upper surface of said support member.

2. A device for facilitating inspection of hosiery, comprising: a base member; a spindle pivotally mounted on said base member; a conical support member rotatable on said spindle and adapted to support a stocking, said spindle being adapted to pivot on said base member in one direction to position a longitudinal portion of said support member horizontally when the device is in use and in the opposite direction to move said support member to substantially vertical position when said device is not in use; a guide member pivotally mounted on said base member and extending longitudinally of and in parallel relation to said longitudinal portion of said support member; connecting means for connecting said spindle and said guide member for unitary pivotal movement; stop means for limiting pivotal movement of said spindle and said guide member in either direction; and a magnifying lens movable along said guide member and said portion of said support member and through which the filaments of said stocking can be viewed.

3. A device for facilitating inspection of hosiery, comprising: a base member; a spindle pivotally

mounted on said base member; a conical support member rotatable on said spindle and adapted to support a stocking, said spindle being adapted to pivot on said base member in one direction to position the upper portion of said support member horizontally when the device is in use and in the opposite direction to move said support member to substantially vertical position when said device is not in use; a guide member pivotally mounted on said base member and extending longitudinally of and in parallel relation to said upper portion of said support member; connecting means for connecting said spindle and said guide member for unitary pivotal movement; adjustable stop means on said base member for limiting pivotal movement of said spindle and said guide member in either direction; a holder member adapted to be slid along said guide member; and a magnifying lens carried by said holder member and through which the filaments of said stocking can be viewed.

4. A device for facilitating inspection of hosiery, comprising: a base member; a spindle pivotally mounted on said base member for movement from a substantially horizontal position to a substantially vertical position; adjustable means for limiting pivotal movement of said spindle in either direction; a hollow translucent conical support member rotatable on said spindle about its longitudinal axis; electric illuminating means carried by said spindle and arranged within said support member for illuminating said support member to cause the filaments of said stocking to be silhouetted thereagainst; an electric circuit for said illuminating means; a switch in said circuit; and means actuated in response to pivotal movement of said spindle to horizontal position for closing said switch and actuated in response to pivotal movement of said spindle to vertical position to open said switch.

5. A device for facilitating inspection of hosiery, comprising: a base member; a spindle pivotally mounted on said base member to adapt it to assume a substantially horizontal operative position when the device is in use and to assume a substantially vertical inoperative position when the device is not in use; adjustable stop means for limiting pivotal movement of said spindle in either direction; a hollow translucent conical support member rotatable on said spindle for supporting a stocking; electric illuminating means carried by said spindle and arranged within said support member for illuminating said support member to cause the filaments of said stocking to be silhouetted thereagainst; an electric circuit for said illuminating means; and a switch carried by said spindle and interposed in said circuit, said switch having spaced contacts and a quantity of mercury flowable across said contacts in response to pivotal movement of said spindle to operative position to close said switch; and flow-

able away from said contacts in response to pivotal movement of said spindle to inoperative position to open said switch.

6. A device for facilitating inspection of hosiery, comprising: a base member; a spindle pivotally mounted on said base member to adapt it to assume a substantially horizontal operative position when the device is in use and to assume a substantially vertical inoperative position when the device is not in use; adjustable stop means for limiting pivotal movement of said spindle in either direction; a hollow translucent conical support member rotatable on said spindle for supporting a stocking; a reflector member carried by said spindle and extending longitudinally within said support member; electric illuminating means carried by said reflector member for illuminating said support member to cause the filaments of said stocking to be silhouetted thereagainst; an electric circuit for said illuminating means; and a mercury switch carried by said spindle and interposed in said circuit, said switch having spaced contacts and a quantity of mercury flowable across said contacts in response to pivotal movement of said spindle to operative position to close said switch, and flowable away from said contacts in response to pivotal movement of said spindle to inoperative position to open said switch.

7. A device for facilitating inspection of hosiery, comprising: a base member; a spindle connected to said base member; a conical, translucent support member rotatable on said spindle and adapted to support a stocking slid thereonto; means disposed within said support member for illuminating said support member to cause the filaments of said stocking to be silhouetted thereagainst; a guide member connected to said base member and projecting therefrom in parallel relation to a line of generation of the conical surface of said support member; and optical magnifying means slidable along said guide member and through which said silhouetted filaments can be viewed.

HENRY GILBERT.

REFERENCES CITED

The following references are of record in the file of this patent:

UNITED STATES PATENTS

Number	Name	Date
983,320	Snyder	Feb. 7, 1911
1,615,216	Cruger	Jan. 25, 1927
1,723,058	Napier	Aug. 6, 1929
1,728,458	Verduce	Sept. 17, 1929
1,877,077	Stevens	Sept. 13, 1932
2,098,955	Dreager	Nov. 16, 1937

FOREIGN PATENTS

Number	Country	Date
485,712	Germany	Nov. 5, 1929