



(51) International Patent Classification:

A61B 17/88 (2006.01) A61B 17/92 (2006.01)  
A61B 17/17 (2006.01) B23B 41/00 (2006.01)  
A61B 17/72 (2006.01) B23B 45/16 (2006.01)

(21) International Application Number:

PCT/CA2012/050808

(22) International Filing Date:

14 November 2012 (14.11.2012)

(25) Filing Language:

English

(26) Publication Language:

English

(30) Priority Data:

61/559,609 14 November 2011 (14.11.2011) US

(71) Applicants: **THE UNIVERSITY OF BRITISH COLUMBIA** [CA/CA]; University Industry Liaison Office, 103-6190 Agronomy Road, Vancouver, British Columbia V6T 1Z3 (CA). **BRITISH COLUMBIA CANCER AGENCY BRANCH** [CA/CA]; 675 West 10th Avenue, Vancouver, British Columbia V5Z 1L3 (CA).

(72) Inventors: **MEEK, Robert**; 1895 West 14th Avenue, Vancouver, British Columbia V6J 2J9 (CA). **ZHU,**

**Qingan**; 500-828 West 10th Avenue, Vancouver, British Columbia V5Z 1L8 (CA). **SCHWAB, Timothy**; 4930 North Meadow Court, Prince George, British Columbia V2K 4E9 (CA). **COOPE, Robin John Noel**; 3080 Alberta Street, Vancouver, British Columbia V5Y 3L9 (CA). **SLOBODAN, Jared**; 7780 Sunnyside Road, Richmond, British Columbia V6Y 1H1 (CA). **YOUNG, Scott**; 3423 Slocan Street, Vancouver, British Columbia V5M 3E7 (CA).

(74) Agents: **ORANGE, John R.S.** et al.; Blake, Cassels & Graydon LLP, Box 25, Commerce Court West, 199 Bay Street, Suite 4000, Toronto, Ontario M5L 1A9 (CA).

(81) Designated States (unless otherwise indicated, for every kind of national protection available): AE, AG, AL, AM, AO, AT, AU, AZ, BA, BB, BG, BH, BN, BR, BW, BY, BZ, CA, CH, CL, CN, CO, CR, CU, CZ, DE, DK, DM, DO, DZ, EC, EE, EG, ES, FI, GB, GD, GE, GH, GM, GT, HN, HR, HU, ID, IL, IN, IS, JP, KE, KG, KM, KN, KP, KR, KZ, LA, LC, LK, LR, LS, LT, LU, LY, MA, MD, ME, MG, MK, MN, MW, MX, MY, MZ, NA, NG, NI, NO, NZ, OM, PA, PE, PG, PH, PL, PT, QA, RO, RS, RU, RW, SC, SD, SE, SG, SK, SL, SM, ST, SV, SY, TH, TJ,

[Continued on next page]

(54) Title: INTRAMEDULLARY FIXATION SYSTEM FOR MANAGEMENT OF PELVIC AND ACETABULAR FRACTURES

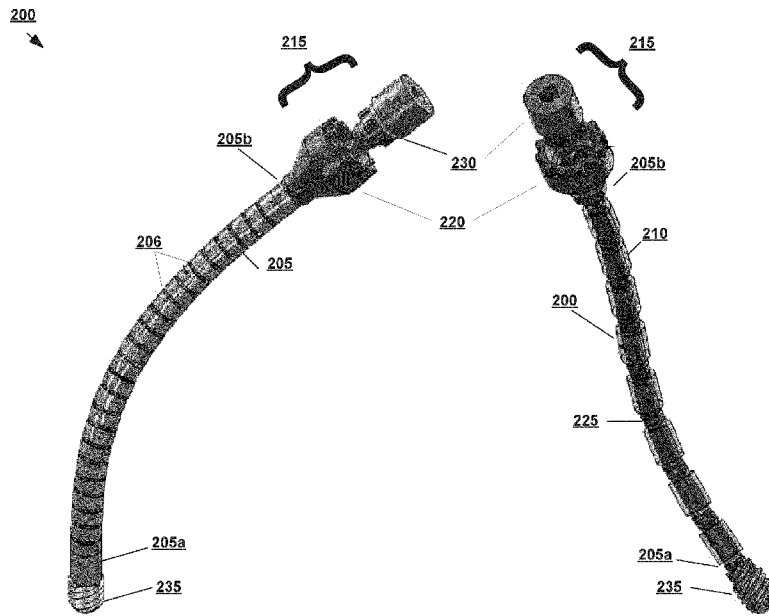

FIG. 2A

FIG. 2B

(57) Abstract: Devices for treating a bone and methods of inserting such devices into a bone are disclosed. A device for treating a bone may include a flexible tube, a stiffening mechanism and an actuator. The flexible tube has a distal end and a proximal end. The stiffening mechanism within the flexible tube is configured to cause the flexible tube to become rigid. The actuator is configured to cause the stiffening mechanism to cause the flexible tube to become rigid in response to the actuator being actuated.

WO 2013/071432 A1



TM, TN, TR, TT, TZ, UA, UG, US, UZ, VC, VN, ZA, ZM, ZW.

EE, ES, FI, FR, GB, GR, HR, HU, IE, IS, IT, LT, LU, LV, MC, MK, MT, NL, NO, PL, PT, RO, RS, SE, SI, SK, SM, TR), OAPI (BF, BJ, CF, CG, CI, CM, GA, GN, GQ, GW, ML, MR, NE, SN, TD, TG).

**(84) Designated States** (*unless otherwise indicated, for every kind of regional protection available*): ARIPO (BW, GH, GM, KE, LR, LS, MW, MZ, NA, RW, SD, SL, SZ, TZ, UG, ZM, ZW), Eurasian (AM, AZ, BY, KG, KZ, RU, TJ, TM), European (AL, AT, BE, BG, CH, CY, CZ, DE, DK,

**Published:**

— *with international search report (Art. 21(3))*

## INTRAMEDULLARY FIXATION SYSTEM FOR MANAGEMENT OF PELVIC AND ACETABULAR FRACTURES

### BACKGROUND

[0001] FIG. 1A depicts a frontal view of the skeletal structure forming the pelvic ring, and FIGS. 1B and 1C depict cross-sectional side views of the skeletal structure forming the pelvic ring. As shown in FIGS. 1A, 1B and 1C, the pelvic ring includes right and left ilium bones **105**, **110**, the sacrum **115** and their associated ligamentous connections. The main connections are through and around the right and left sacroiliac joints **120**, **125** at the posterior of the pelvis and the pubic symphysis **130** at the anterior of the pelvis. The pelvic ring is a key structural element of the skeletal system because it is a weight-bearing structure interposed between the upper body and the legs. As such, if a fracture occurs and it is untreated, the pelvic ring may not heal (nonunion) or may heal in a poor position (malunion). Nonunion can lead to chronic pain and an inability to walk. Malunion can result in a short leg or one which points in the wrong direction. Because of these problems, it is necessary to reposition to normal the fragments which have become displaced during the fracturing (reduction). Once the fragments are repositioned, it is necessary to hold them in place (fixation) until the healing of the fracture is complete. This process may take approximately 6 to 8 weeks.

[0002] Because the pelvic ring forms a ring structure, it cannot be disrupted in one place when a fracture occurs. Typically, a disruption, or "break," occurs in both the posterior and anterior portions of the pelvic ring. The disruptions in the pelvic ring can be through one or more of the bones **105**, **110**, **115**, through the posterior sacroiliac joints **120**, **125**, through the pubic symphysis **130** at the front, or any number of combinations of the above. If the acetabulum (a portion of each ilium bone **105**, **110** forming the hip socket) is fractured, the smooth bearing surface of the acetabulum must be restored to as close to its original shape as

possible in order to allow for proper movement at the hip. Once restored, the acetabulum must be held in the restored position until healing occurs.

**[0003]** Conventional treatment of a pelvic fracture includes reduction of the fracture fragments and fixation with plates and screws along the surface of the bone. However, placing a plate on the bone requires a significant operation with resulting high blood loss. In some cases, a straight intramedullary screw may be placed along a curved path. While the screw is less invasive, the fixation may be inadequate because the straight screw cannot be implanted very far into a curved bone. This may result in inadequate fixation. Moreover, the screw must be relatively small in diameter to avoid extending through the bone. Surgically speaking, implanting a screw such that it extends from the bone can result in significant hazard to the patient because it may puncture or otherwise impinge upon important vascular and nervous structures.

#### SUMMARY

**[0004]** This disclosure is not limited to the particular systems, devices and methods described, as these may vary. The terminology used in the description is for the purpose of describing the particular versions or embodiments only, and is not intended to limit the scope.

**[0005]** As used in this document, the singular forms “a,” “an,” and “the” include plural references unless the context clearly dictates otherwise. Unless defined otherwise, all technical and scientific terms used herein have the same meanings as commonly understood by one of ordinary skill in the art. Nothing in this disclosure is to be construed as an admission that the embodiments described in this disclosure are not entitled to antedate such disclosure by virtue of prior invention. As used in this document, the term “comprising” means “including, but not limited to.”

**[0006]** In an embodiment, a device for treating a fracture of a bone may include a flexible tube having a distal end and a proximal end, a stiffening mechanism within the flexible tube configured to cause the flexible tube to become rigid, and an actuator configured to cause the stiffening mechanism to cause the flexible tube to become rigid in response to the actuator being actuated.

**[0007]** In an embodiment, a method of treating a fracture of a bone may include inserting a guide wire including a bent section having a sharpened tip at a distal portion of the guide wire into an intramedullary space of the bone, forming a tunnel surrounding the guide wire in the bone, inserting a flexible device into the tunnel, and causing the flexible device to become rigid in the tunnel in order to fix a fracture of the bone.

**[0008]** In an embodiment, a device for treating a fracture of a bone may include a flexible tube having a distal end and a proximal end, a plurality of rods contained within the flexible tube, and an actuator configured to cause the plurality of rods to be fixed in place when actuated.

**[0009]** In an embodiment, a device for treating a fracture of a curved bone may include a flexible tube having a distal end and a proximal end, a spring contained within the flexible tube, an actuator configured to cause the spring to exert a normal force against an inner surface of the flexible tube in response to the actuator being actuated.

**[0010]** In an embodiment, a kit may include a flexible device comprising a flexible tube having a distal end and a proximal end, and an actuator configured to cause the stiffening mechanism to cause the flexible tube to become rigid in response to the actuator being actuated, and instructions for using the flexible device to fix a bone fracture.

**[0011]** In an embodiment, a device for treating a fracture of a bone may include a flexible tube having a distal end and a proximal end and including a series of slits configured to allow the flexible tube to flex, a high helix angle screw positioned at the distal end of the

flexible tube, a plurality of bead segments, including a distal bead segment and a proximal bead segment, within the flexible tube configured to cause the flexible tube to become rigid, wherein each of the plurality of bead segments comprises a distal end, a proximal end and a bore, a cannula extending through the bore of each of the plurality of bead segments and having a distal end connected to the distal bead segment and a proximal end extending from the proximal end of the flexible tube, and a cap connected to the proximal end of the flexible tube and configured to permit the flexible tube to be rotated.

**[0012]** In an embodiment, a device for treating a bone may include a plurality of bead segments including a distal bead segment and a proximal bead segment where each of the plurality of bead segments comprises a distal end, a proximal end and a bore, a screw head in contact with a distal end of the distal bead segment, a stiffening cable extending through the bore of each of the plurality of bead segments, and a tensioning assembly in contact with a proximal end of the proximal bead segment. The tensioning assembly may be configured to cause the stiffening cable to cause the proximal end of each bead segment to engage a distal end of an adjacent bead segment. The stiffening cable may have a distal end connected to the screw head and a proximal end connected to the tensioning assembly.

#### BRIEF DESCRIPTION OF THE FIGURES

**[0013]** FIG. 1A depicts a frontal view of the skeletal structure forming the pelvic ring.

**[0014]** FIGS. 1B and 1C depict cross-sectional side views of the skeletal structure forming the pelvic ring.

**[0015]** FIG. 2A depicts an exemplary device for treating a bone according to an embodiment.

[0016] FIG. 2B depicts interior portions of the exemplary device of FIG. 2A according to an embodiment.

[0017] FIG. 3 depicts an exemplary expansion sleeve according to an embodiment.

[0018] FIG. 4 depicts an alternate exemplary expansion sleeve according to an embodiment.

[0019] FIG. 5 depicts an alternate exemplary expansion sleeve according to an embodiment.

[0020] FIG. 6 depicts an exemplary bead segment and flexible device incorporating a plurality of bead segments according to an embodiment.

[0021] FIG. 7 depicts a flow diagram for an exemplary method of treating a bone according to an embodiment.

[0022] FIG. 8 depicts an alternate exemplary device for treating a bone according to an embodiment.

[0023] FIGS. 9A and 9B depict an external view and a cut-away view, respectively, of exemplary bead segments according to an embodiment.

[0024] FIGS. 10A-D depict points of contact between the exemplary bead segments of FIGS. 9A and 9B.

[0025] FIG. 11 depicts a flexible device incorporating a plurality of bead segments according to an embodiment.

[0026] FIGS. 12A and 12B depict an exploded view and a cut-away view of an exemplary tensioning assembly according to an embodiment.

#### DETAILED DESCRIPTION

[0027] The following term shall have, for the purposes of this application, the meaning set forth below.

[0028] The terms “fixing” or “to fix” refer to holding or setting something in place. In particular, a bone fracture may be fixed by causing a device placed across the point of fracture to become rigid, thereby stabilizing the bone on either side of the fracture. Additionally, the device itself may become fixed by making the device become rigid as a result of actuation of an actuator.

[0029] FIG. 2A depicts an exemplary device for treating a bone according to an embodiment. FIG. 2B depicts interior portions of the exemplary device according to an embodiment. As shown in FIGS. 2A and 2B, the device **200** may include a flexible tube **205**, a stiffening mechanism **210** and an actuator **215**. The flexible tube **205** may have a distal end **205a** and a proximal end **205b**. The flexible tube **205** may include a plurality of slits, such as **206**, in an outer housing configured to allow the flexible tube to flex. In an embodiment, the flexible tube **205** may comprise stainless steel and/or nitinol.

[0030] The stiffening mechanism **210** may be located within the flexible tube **205** and may be configured to cause the flexible tube to become rigid. In an embodiment, the stiffening mechanism **210** may include a plurality of expansion sleeves. Exemplary expansion sleeves are disclosed in FIGS. 3-5 and are discussed in further detail below.

[0031] FIG. 3 depicts an exemplary expansion sleeve according to an embodiment. As shown in FIG. 3, the expansion sleeve may include a jam nut **305** having expansion beads **310a** and **310b**, cladding **315** covering at least a portion of the expansion beads, a plurality of expanding segments, such as **320**, and a bore **325**. The jam nut **305** may include an expansion bead **310a** having a convex end and an expansion bead **310b** having a concave end. Each of the expansion beads **310a** and **310b** may taper down in diameter from the convex/concave end to the other end of the bead. The convex expansion bead **310a** of a first expansion sleeve and the concave expansion bead **310b** of a second adjacent expansion sleeve are configured to enable the adjacent expansion sleeves to abut each other when the

actuator **215** is actuated. The cladding **315** may be made of, for example and without limitation, silicone and may provide some compliance when the expansion sleeve **305** contacts the interior surface of the flexible tube **205**. The jam nut **305** may be actuated by causing the expansion beads **310a** and **310b** to be moved towards each other causing the cladding **315** to expand. As such, the expanding segments **320** may be configured to be in a non-actuated state against the cladding **315** when the jam nut **305** is not actuated. In contrast, when the jam nut **305** is actuated, the cladding **315** may force the expanding segments **320** to abut an interior surface of the flexible tube **205**. As such, the expanding segments **320** may cause the flexible tube **205** to become rigid when the jam nut **305** is in an actuated state. The bore **325** may be configured to receive a cannula, as discussed below.

[0032] FIG. 4 depicts an alternate exemplary expansion sleeve according to an embodiment. As shown in FIG. 4, expansion sleeve **405** may include expansion beads **410a** and **410b**, a retaining spring **415**, a plurality of expanding segments, such as **420**, and a bore **425**. The expansion sleeves may include an expansion bead **410a** having a convex end and an expansion bead **410b** having a concave end. Each of the expansion beads **410a** and **410b** may taper down in diameter from the convex/concave end to the other end of the bead. The convex expansion bead **410a** of a first expansion sleeve and the concave expansion bead **410b** of a second adjacent expansion sleeve are configured to enable the adjacent expansion sleeves to abut each other when the actuator **215** is actuated. The retaining spring **415** may provide some compliance when the expansion sleeve **405** contacts the interior surface of the flexible tube **205**. The expansion sleeve **405** may be actuated by causing the expansion beads **410a** and **410b** to be moved towards each other causing the expanding segments **420** to be pushed towards an inner surface of the flexible tube **205**. As such, the retaining spring **415** may be configured to restrain the expanding segments **420** when in a non-actuated state. In contrast, when the actuator **215** is actuated, the expanding segments **420** may be configured

to abut an interior surface of the flexible tube **205**. In this way, the expanding segments **420** may cause the flexible tube **205** to become rigid when in an actuated state. The bore **425** may be configured to receive a cannula, as discussed below.

**[0033]** FIG. 5 depicts an alternate exemplary expansion sleeve according to an embodiment. As shown in FIG. 5, expansion sleeve **505** may include expansion beads **510a** and **510b**, one or more O-rings **515**, a plurality of expanding segments, such as **520**, and a bore **525**. The expansion sleeves may include an expansion bead **510a** having a convex end and an expansion bead **510b** having a concave end. Each of the expansion beads **510a** and **510b** may taper down in diameter from the convex/concave end to the other end of the bead. The convex expansion bead **510a** of a first expansion sleeve and the concave expansion bead **510b** of a second adjacent expansion sleeve are configured to enable the adjacent expansion sleeves to abut each other when the actuator **215** is actuated. The one or more O-rings **515** may provide some compliance when the expansion sleeve **505** contacts the interior surface of the flexible tube **205**. The expansion sleeve **505** may be actuated by causing the expansion beads **510a** and **510b** to be moved towards each other causing the expanding segments **520** to be pushed towards an inner surface of the flexible tube **205**. As such, the one or more O-rings **515** may be configured to restrain the expanding segments **520** when in a non-actuated state. In contrast, when the actuator **215** is actuated, the expanding segments **520** may be configured to abut an interior surface of the flexible tube **205**. As such, the expanding segments **520** may cause the flexible tube **205** to become rigid when in an actuated state. The bore **525** may be configured to receive a cannula, as discussed below.

**[0034]** The expansion sleeves discussed in FIGS. 3-5 are exemplary and are not meant to be limiting. Additional and/or alternate devices for forming expansion sleeves may be used within the scope of this disclosure.

[0035] Referring back to FIG. 2, the actuator **215** may be configured to cause the stiffening mechanism **210** to cause the flexible tube **205** to become rigid in response to the actuator being actuated. In an embodiment, the actuator **215** may include, for example and without limitation, a cap **220** connected to the proximal end of the flexible tube **205**. In an embodiment, the cap **220** may be configured to permit the flexible tube **205** to be rotated, thereby allowing the flexible tube to be inserted into a bone. The cap **220** may also be configured to cause the stiffening mechanism **210** to become rigid. For example, if the stiffening mechanism **210** comprises a plurality of expansion sleeves, the cap **220**, when rotated, may be configured to cause each of the plurality of expansion sleeves to abut an interior surface of the flexible tube **205**.

[0036] In an alternate embodiment, the actuator **215** may include a cannula **225** with a locking assembly **230**. The cannula **225** may extend through a bore in each of a plurality of expansion sleeves, such as **305**, **405** or **505**. The cannula **225** may include a distal end connected to a distal expansion sleeve located at the distal end of the flexible tube **205** and a proximal end extending from the proximal end of the flexible tube. In an embodiment, the cannula **225**, when actuated, may cause the plurality of expansion sleeves **305**, **405** or **505** to actuate, which may cause the flexible tube **205** to become rigid, as described above. The locking assembly **230** may be used to actuate the cannula **225**. For example, the locking assembly **230** may cause the cannula **225** to become tensioned. The locking assembly **230** may then be used to lock the cannula **225** in the actuated state.

[0037] In an alternate embodiment, the cannula **225** may extend through a bore in each of a plurality of bead segments, such as **605** in FIG. 6. Each of the bead segments **605** may further include a distal end and a proximal end. In an embodiment, the distal end of a bead segment **605** may be sized and shaped to be received by, receive or otherwise engage a proximal end of an adjacent bead segment in response to the cannula **225** being actuated. For

example, the distal end of each bead segment **605** may be convex, and the proximal end of each bead segment may be concave. Conversely, the distal end and proximal end of each bead segment **605** may be concave and convex, respectively. Additional or alternate shapes for the distal and proximal ends of bead segments **605** may be used within the scope of this disclosure.

[0038] In an embodiment, each of the bead segments **605** may be about 8 mm in diameter and about 12 mm in length. In an embodiment, each of the bead segments **605** may be about 2 mm to about 15 mm in diameter. In an embodiment, each of the bead segments **605** may be about 5 mm to about 25 mm in length. Alternately sized bead segments **605** may also be used within the scope of this disclosure.

[0039] The cannula **225** may include a distal end connected to a distal bead segment located at the distal end of the flexible tube **205** and a proximal end extending from the proximal end of the flexible tube. In an embodiment, the cannula **225**, when actuated, may cause the plurality of bead segments **605** to actuate, which may cause the flexible tube **205** to become rigid. The locking assembly **230** may be used to actuate the cannula **225**. For example, the locking assembly **230** may cause the cannula **225** to become tensioned. The locking assembly **230** may then be used to lock the cannula **225** in the actuated state.

[0040] In an embodiment, a screw **235** may additionally be positioned at the distal end of the flexible tube **205**. The screw **235** may be used to enable the flexible tube **205** to be inserted into a bone. In an embodiment, the screw **235** may be a high helix angle screw. In an embodiment, the screw **235** may move a distance into a medium, such as a bone, that is approximately equal to its diameter when rotated one revolution. In other words, a screw **235** having a diameter of 12 mm may move forward approximately 12 mm when rotated once.

[0041] FIG. 7 depicts a flow diagram for an exemplary method of treating a bone according to an embodiment. As shown in FIG. 7, a guide wire may be inserted **705** into an

intramedullary space of a bone. The guide wire may include a bent section having a sharpened tip at a distal portion of the guide wire. The guide wire may be inserted **705** by rotating the guide wire to orient the bent section of the guide wire and selectively hammering the guide wire to cause the bent section to form a curved path in bone based on the orientation of the bent section. In an embodiment, inserting **705** the guide wire may include using a fluoroscope to determine the orientation of the bent section of the guide wire. In an embodiment, the guide wire may be attached to a hammer drill during insertion **705**. During insertion of the guide wire, a user may orient the bent tip so that it is positioned in the direction that the guide wire is to be inserted **705**. The hammer drill may then be activated to cause the guide wire to be inserted into the bone in such direction. In particular, the sharpened tip may be used to cause the hole to be formed in the bone. If the user determines that the direction of insertion **705** for the guide wire is to be changed, the guide wire may be re-oriented prior to further insertion of the guide wire. In an embodiment, a straight path may be approximated by inserting the guide wire in a succession of short curved paths that are substantially 180 degrees opposed to each other. As such, although the present method may be used to insert a guide wire into curved bone, such as at least a portion of a pelvic ring, a posterior column of an acetabulum or an anterior column of an acetabulum of a patient, the method may also be used to insert a guide wire into a substantially straight bone as well.

**[0042]** In an embodiment, the guide wire may include one or more of stainless steel and nitinol. In an embodiment, the guide wire may be about 1 mm to about 1.5 mm in diameter. It will be apparent to those of ordinary skill in the art that the guide wire may be of a different size depending upon the particular bone into which the guide wire is to be inserted and that the disclosed size range is merely exemplary.

**[0043]** A tunnel may be formed **710** surrounding the guide wire in the bone. In an embodiment, the tunnel may be formed **710** using a cannulated reamer with a flexible drive

shaft that fits over and around the guide wire. The cannulated reamer may include a bore configured to receive the guide wire. As such, the guide wire may guide the direction of the cannulated reamer in forming **710** the space in the bone.

**[0044]** The cannulated reamer may be configured to have a diameter sufficient to allow a flexible device, such as at least one of the flexible tubes described in reference to FIGS. 2, 6 and 8, to be inserted **715** into the tunnel. In an embodiment, the cannulated reamer may be short enough to enable the reamer to form and follow a curved hole defined by the guide wire.

**[0045]** The flexible device may be caused **720** to become rigid when in the tunnel. In particular, the rigid flexible device may be used to treat a bone fracture. In an embodiment, the flexible device may be caused **720** to become rigid by operating an actuator and, in response to operating the actuator, rigidizing the flexible device from a flexible state to a more rigid state. For example, expansion sleeves, jam nuts and/or bead segments described above in reference to FIGS. 3-6 may be used to abut against an interior surface of the flexible device causing the flexible device to hold its shape when actuated. In an embodiment, the expansion sleeves may include one or more of a spring, one or more jam nuts and one or more O-rings. In an embodiment, a flexible device may be caused **720** to become rigid by actuating a cannula extending through each of a plurality of expansion sleeves. In an alternate embodiment, a flexible device may be caused **720** to become rigid by rotating a cap located at a proximal end of the flexible device.

**[0046]** FIG. 8 depicts an alternate exemplary device for treating a bone according to an embodiment. As shown in FIG. 8, the device **800** may include a flexible tube **805**, a plurality of rods **810** contained within the flexible tube, and an actuator (not shown). The flexible tube **805** may include a distal end and a proximal end. In an embodiment, the

flexible tube **805** may include a series of slits configured to allow the tube to flex. In an embodiment, the flexible tube **805** may include stainless steel and/or nitinol.

[0047] In an embodiment, the plurality of rods **810** may be affixed to each other at the distal end of the flexible tube **805** and/or affixed to the distal end of the flexible tube. The plurality of rods **810** may substantially or completely fill the flexible tube **805** such that the rods cannot substantially move with respect to each other inside the flexible tube. In particular, the rods **810** remain parallel to each other and are constrained from deflecting in a radial direction. In an embodiment, the plurality of rods **810** move axially as the flexible tube **805** is flexed. As such, a rod **810** positioned along the inside of a curve traverses a shorter distance than a rod positioned along the outside of the curve, where the relative lengths of the rods change as the curve is modified.

[0048] The actuator may be configured to cause the plurality of rods to be fixed in place when actuated. In an embodiment, the actuator may be configured to cause the plurality of rods **810** to be fixed in place by causing the plurality of rods to lock in place at the proximal end of the flexible tube **805**. If the plurality of rods **810** are locked together at the proximal end of the flexible tube **805**, any curve(s) in the tube may be fixed in place.

[0049] In an embodiment, the device **800** may further include a screw **815** positioned at the distal end of the flexible tube **805**. The screw **815** may be used to enable the flexible tube **805** to be inserted into a bone. In an embodiment, the screw **815** may be a high helix angle screw. In an embodiment, the screw **815** may move a distance into a medium, such as a bone, that is approximately equal to its diameter when rotated one revolution. In other words, a screw **815** having a diameter of 12 mm may move forward approximately 12 mm when rotated once.

[0050] In an embodiment, the device **800** may further include a sleeve (not shown) located within the flexible tube **805**. The sleeve may be configured to contain the plurality of

rods **810**. In an embodiment, the actuator may be configured to cause the plurality of rods **810** to be fixed by causing the sleeve to apply a normal force towards a center of the sleeve in response to the actuator being actuated. As such, the sleeve may compress the plurality of rods **810** causing the rods to be incapable of movement, thereby causing the flexible tube **805** to become rigid.

**[0051]** In an embodiment, a device for treating a bone may include a flexible tube similar to one of the flexible tubes described above, a spring contained within the flexible tube and an actuator configured to cause the spring to exert a normal force against an inner surface of the flexible tube in response to the actuator being actuated. The normal force exerted by the spring may cause the flexible tube to become rigid. The flexible tube may include a series of slits configured to allow the tube to flex. The flexible tube may include stainless steel and/or nitinol. In an embodiment, a screw may be positioned at the distal end of the flexible tube.

**[0052]** In an embodiment, a bone-treating device may be manufactured in the following manner or by performing similar operations. A flexible tube may be formed of a flexible material, such as super-elastic nitinol or spring-tempered stainless steel. The flexible tube may include a plurality of slits to allow the tube to be axially flexible, but stiff in torsion. Alternately, a gooseneck wound spring may be used. In an embodiment, a screw may be attached to a distal end of the flexible tube, and a cap may be attached to a proximal end of the flexible tube. The cap may include a structure that permits the cap to be turned by a wrench.

**[0053]** A stiffening system is inserted into the flexible tube such that a distal end of the stiffening system is attached to a distal end of the flexible tube. The stiffening system includes a cannula connected at a distal end to the distal end of the flexible tube and a plurality of bead segments or expansion sleeves threaded along the cannula. Each of the bead

segments or expansion sleeves includes a bore permitting the cannula to pass therethrough. The bead segments and expansion sleeves are described in greater detail in reference to FIGS. 3-6.

**[0054]** Alternately, the stiffening system includes a plurality of thin rods attached at a distal end of the flexible tube. In an embodiment, the thin rods may be inserted inside of a sleeve surrounding the thin rods that is configured to prevent the rods from moving when actuated. Alternately, the stiffening system may include a lock at the proximal end of the flexible tube that is used to lock the thin rods in place.

**[0055]** In an embodiment, a bone containing a device for treating the bone may include the bone, and a device comprising a tube having a distal end and a proximal end, a stiffening mechanism configured to cause the tube to remain in a rigid state. In an embodiment, the device may include a screw positioned at the distal end of the tube.

**[0056]** In an embodiment, the stiffening mechanism may include a plurality of bead segments including a distal bead segment. Each of the plurality of bead segments may include a distal end and a proximal end. The distal end of each bead segment of the plurality of bead segments, other than the distal bead segment, may receive the proximal end of an adjacent bead segment of the plurality of bead segments. In an embodiment, each of the bead segments may be about 8 mm in diameter and about 12 mm in length. In an embodiment, each of the bead segments may be about 2 mm to about 15 mm in diameter. In an embodiment, each of the bead segments may be about 5 mm to about 25 mm in length. Alternately sized bead segments may also be used within the scope of this disclosure.

**[0057]** In an alternate embodiment, the stiffening mechanism may include a plurality of expansion sleeves. An expansion sleeve may include, for example and without limitation, a spring, one or more jam nuts, and/or one or more O-rings.

**[0058]** The above-described devices and methods may be used to treat a bone fracture. For example, bone fragments at the point of a fracture may be repositioned into a proper alignment, and a device, such as one described above, may be inserted in order to fix the bone fracture to allow healing to complete.

**[0059]** Alternately, the above-described devices and methods may be used to prophylactically treat a bone in order to provide support. For example, a metastatic tumor may cause a weak spot in a bone. A device may be inserted to provide support for such a weak spot. As another example, a device may be inserted to support the posterior and anterior columns of the acetabulum for the management of a complex total hip replacement procedure or a revision of a previous total hip replacement. Additional uses of the devices and methods described herein may also be performed within the scope of this disclosure.

**[0060]** In an alternate embodiment, a device without a flexible tube may be manufactured for use as described above. FIGS. 9A and 9B depict an external view and a cut-away view, respectively, of exemplary bead segments according to an embodiment. As shown in FIGS. 9A and 9B, the bead segments, such as **900**, may include a male surface **905** and a female (hollow) surface **910** and a bore. The bore of each bead segment may be configured to receive a stiffening cable or cannula as described above in reference to FIGS. 3-6.

**[0061]** The male surface **905** and the female surface **910** may have a shape that permits torque transfer from one bead segment to the next. For example, the male surface **905**, and the female surface **910** may have a spherical and at a proximal end and a conical cross-section at a distal end, as described further below in reference to FIGS. 10A-D. Alternate cross-sectional shapes may also be used for the male surface **905** and the female surface **910** within the scope of this disclosure. For example, other multisided shapes, such as square cross-sections, pentagonal cross-sections, hexagonal cross-sections, heptagonal

cross-sections, octagonal cross-sections, spherical cross-sections, conical cross-sections or the like, may be used within the scope of this disclosure.

[0062] The shapes of the male surface **905** and the female surface **910** of adjacent bead segments may permit torque to be transmitted from one bead to the next to drive a distal screw (such as **1110** in FIG. 11). In addition, the shapes of the male surface **905** and the female surface **910** of adjacent bead segments may enable the bead segments to pivot with respect to each other allowing the chain to form curved shapes.

[0063] The male surface **905** of each bead segment may include a narrowed neck **915** proximal to the ball to increase the bead-to-bead rotational angle. The narrowed neck **915** may further enable the open ends of the female surface **910** of an adjacent bead to be modified such that the male surface **905** of the bead cannot disengage. In an embodiment, the female surface **915** may be modified post-assembly in order to secure the connection. For example, a circlip may be added to a groove on the inside of the cavity of the female surface **915**. Alternately, the edge of the female surface **915** may be crimped or rolled such that the inner diameter of the female surface is reduced at the edge. In this manner, a string of bead segments may be kept in an interlocked arrangement even if a central stiffening cable (not shown) is broken.

[0064] FIGS. 10A-D depict points of contact between the exemplary bead segments of FIGS. 9A and 9B. The male surface **905** and the female surface **910** of adjacent bead segments **900** have shapes that are capable of transmitting torque, such as hexagons. FIGS. 10A-D identify details of how the male surface **905** and the female surface **910** of the adjacent bead segments **900** interact. The female surface **910** may be substantially straight-sided with a cross-section that is similar in nature to the male surface **905** of the adjacent bead segment **900**. At the distal end of the female surface **910**, a cone shape having a circular cross-section may be used. The corners of the male surface **905** of the adjacent bead segment

**900** may make point contact with the cone-shaped portion of the female surface **910**. This may cause localized points of high stress, which may lead to improved friction over line contact. In particular, the conical-shaped portion of the female surface **910** may permit improved friction as compared to a hexagonal prism because the hexagonal prism may not make even line contact around the male socket **905** as the adjacent bead segments **900** pivot with respect to each other. The described design may enable an interference fit, such as is shown in FIG. 10D, which may enable even higher friction as the point regions are distorted.

**[0065]** FIG. 11 depicts a flexible device incorporating a plurality of bead segments according to an embodiment. As shown in FIG. 11, the flexible device **1100** includes a plurality of bead segments, such as **1105**, a distal screw **1110**, a stiffening cable (not shown) inside the flexible device, and a tensioning assembly **1115**. Each bead segment **1105** may be substantially similar to any of the bead segments identified herein or any other bead segment possessing similar characteristics to a bead segment identified within the scope of this disclosure, without limitation.

**[0066]** The stiffening cable may be a multi-stranded wire that passes through the bead segments **1105**. The stiffening cable may be anchored at the distal screw **1110** at the distal end of the flexible device **1100** and at the tensioning assembly **1115** at a proximal end of the flexible device. In an embodiment, the stiffening cable may be anchored at each of the distal and proximal ends by thermal welding, soldering, gluing, welding a tapered collet in place or the like.

**[0067]** While the stiffening cable may be soldered to an anchor so that stress is distributed along an entire hole in which the stiffening cable is anchored such that the solder may wick throughout the hole, a mechanically suitable solder may not be biocompatible. In an embodiment, soldering the stiffening cable to a tapered collet may be used to avoid bioincompatibility within a patient. The collet may be fitted over a stiffening cable and then

pressed into a conical hole, which distorts the collet into the cable. The collet may be welded in place at its outside edge so that the cable itself does not experience heating. In such an embodiment, the stiffening cable may receive substantially equal stress in each direction around the tapered collet.

[0068] FIGS. 12A and 12B depict an exploded view and a cut-away view of an exemplary tensioning assembly 1115 according to an embodiment. As shown in FIG. 12A, the tensioning assembly 1115 may include a hex ball tensioner 1205, a cable anchor 1210, a tensioning sleeve 1215, a collet 1220 and a lock nut 1225. A stiffening cable may be located in the center of the tensioning assembly 1115, but is not shown in FIGS. 12A and 12B to enable better viewing of the remaining components of the tensioning assembly.

[0069] In an embodiment, the stiffening cable may be secured with the tapered collet 1220 resting in the socket of the cable anchor 1210. The tensioning sleeve 1215 may be threaded over the cable anchor 1210. The cable anchor 1210 may have a square rod which slides in the hex ball tensioner 1205. In operation, the cable anchor 1210 may be held in place by a user operated tool while the tensioning sleeve 1215 is threaded in. Threading in the tensioning sleeve 1215 may cause the cable anchor 1210 to be pushed out. A spline of the cable anchor 1210, when held by a user such as a surgeon, may prevent the entire assembly from rotating while the tensioning sleeve 1215 is rotated by a second external tool. The lock nut 1225 may be applied. In an embodiment, the lock nut 1225 may have the same thread pitch inside and out. As such, the lock nut 1225 may be threaded into the bone as it threads onto the cable anchor 1210 without drawing the cable anchor out of the bone, such as the pelvis, into which it is inserted. Application of the tensioning assembly 1115 may cause the flexible device to become rigid within the patient in order to assist in fixing the bone.

**EXAMPLE 1: KIT FOR MEDICAL USE**

[0070] A kit may be sold to physicians, surgeons or other medical professionals or medical institutions for use in treating a bone fracture. The kit includes a flexible device similar to those discussed above (e.g., device **200** or device **800**). The kit may also include a hammer drill (or hammer drill attachment for a surgical drill) and a guide wire configured to be attached to the hammer drill (or hammer drill attachment). The guide wire includes a bent section having a sharpened tip at a distal portion of the guide wire. The kit may also include a cannulated reamer. The cannulated reamer includes a flexible drive shaft and a bore configured to receive the guide wire. The kit may further include instructions for using the flexible device to treat a bone fracture. In particular, the kit may include instructions for using the hammer drill, guide wire and/or cannulated reamer to insert the guide wire into a bone and to use the cannulated reamer to form a tunnel in the bone using the guide wire as a guide. The instructions for inserting the guide wire using the hammer drill may include instructions for rotating the guide wire into a particular orientation based on the direction of the hole to be formed and instructions for using the hammer drill to form the hole.

**EXAMPLE 2: MEDICAL DEVICE USING EXPANSION SLEEVES**

[0071] A flexible device for treating a bone includes a nitinol flexible tube having a plurality of slits configured to allow the flexible device to flex, a plurality of expansion sleeves contained within the flexible tube, and a cannula configured to actuate the bead segments. The cannula, when actuated, may cause each expansion sleeve to expand and abut an inner surface of the flexible tube, thereby causing the flexible device to become rigid. An exemplary medical device using expansion sleeves is disclosed in FIG. 2.

**EXAMPLE 3: EXPANSION SLEEVE WITH SILICONE CLADDING**

[0072] An expansion sleeve includes a jam nut having expansion beads, silicone cladding covering at least a portion of the expansion beads, a plurality of expanding segments and a bore configured to receive a cannula. Adjacent expansion beads are configured to engage each other based on the size and shape of their adjacent surfaces when actuated. For example, adjacent surfaces may be convex and concave. Each of the expansion beads may taper down in diameter from an exposed surface to an internal surface of the bead. The jam nut is actuated by causing the expansion beads to be moved towards each other, which, in turn, causes the cladding to expand. As such, the expanding segments are configured to be in a non-actuated state against the cladding when the jam nut is not actuated. In contrast, when the jam nut is actuated, the cladding forces the expanding segments to abut an interior surface of the flexible tube. As such, the expanding segments cause the flexible tube to become rigid when the jam nut is in an actuated state.

**EXAMPLE 4: EXPANSION SLEEVE WITH RETAINING SPRING**

[0073] An expansion sleeve includes expansion beads, a retaining spring, a plurality of expanding segments and a bore configured to receive a cannula. Adjacent expansion beads are configured to engage each other based on the size and shape of their adjacent surfaces when actuated. For example, adjacent surfaces may be convex and concave. The expansion sleeve is actuated by causing the expansion beads to be moved towards each other causing the expanding segments to be pushed towards an inner surface of the flexible tube. As such, the retaining spring is configured to restrain the expanding segments when in a non-actuated state. In contrast, when the actuator is actuated, the expanding segments are configured to abut an interior surface of the flexible tube. In this way, the expanding segments cause the flexible tube to become rigid when in an actuated state.

**EXAMPLE 5: EXPANSION SLEEVE WITH O-RINGS**

[0074] An expansion sleeve includes expansion beads, one or more O-rings, a plurality of expanding segments, and a bore configured to receive a cannula. Adjacent expansion beads are configured to engage each other based on the size and shape of their adjacent surfaces when actuated. For example, adjacent surfaces may be convex and concave. The expansion sleeve is actuated by causing the expansion beads to be moved towards each other causing the expanding segments to be pushed towards an inner surface of the flexible tube. As such, the one or more O-rings are configured to restrain the expanding segments when in a non-actuated state. In contrast, when the actuator is actuated, the expanding segments are configured to abut an interior surface of the flexible tube. As such, the expanding segments cause the flexible tube to become rigid when in an actuated state.

**EXAMPLE 6: MEDICAL DEVICE USING BEAD SEGMENTS**

[0075] A flexible device for treating a bone includes a stainless steel flexible tube having a plurality of slits configured to allow the flexible device to flex, a plurality of bead segments contained within the flexible tube, and a cannula configured to actuate the bead segments. The cannula, when actuated, may cause each bead segment to engage adjacent bead segments, thereby stiffening the bead segments and causing the flexible device to become rigid. An exemplary medical device using bead segments is disclosed in FIG. 6.

**EXAMPLE 7: MEDICAL DEVICE USING RODS**

[0076] A flexible device includes a flexible tube, a sleeve within the flexible tube and a plurality of rods contained within the sleeve. The rods are configured to be connected to a distal end of the flexible tube and to bend as the flexible tube is flexed. The sleeve, when actuated, is configured to compress the rods together to restrict their movement in a lateral

direction (i.e., in the proximal or distal directions with respect to the flexible tube). An exemplary medical device using rods is disclosed in FIG. 8.

[0077] In the above detailed description, reference is made to the accompanying drawings, which form a part hereof. In the drawings, similar symbols typically identify similar components, unless context dictates otherwise. The illustrative embodiments described in the detailed description, drawings, and claims are not meant to be limiting. Other embodiments may be used, and other changes may be made, without departing from the spirit or scope of the subject matter presented herein. It will be readily understood that the aspects of the present disclosure, as generally described herein, and illustrated in the Figures, can be arranged, substituted, combined, separated, and designed in a wide variety of different configurations, all of which are explicitly contemplated herein.

[0078] The present disclosure is not to be limited in terms of the particular embodiments described in this application, which are intended as illustrations of various aspects. Many modifications and variations can be made without departing from its spirit and scope, as will be apparent to those skilled in the art. Functionally equivalent methods and apparatuses within the scope of the disclosure, in addition to those enumerated herein, will be apparent to those skilled in the art from the foregoing descriptions. Such modifications and variations are intended to fall within the scope of the appended claims. The present disclosure is to be limited only by the terms of the appended claims, along with the full scope of equivalents to which such claims are entitled. It is to be understood that this disclosure is not limited to particular methods, reagents, compounds, compositions or biological systems, which can, of course, vary. It is also to be understood that the terminology used herein is for the purpose of describing particular embodiments only, and is not intended to be limiting.

[0079] With respect to the use of substantially any plural and/or singular terms herein, those having skill in the art can translate from the plural to the singular and/or from the singular to the plural as is appropriate to the context and/or application. The various singular/plural permutations may be expressly set forth herein for sake of clarity.

[0080] It will be understood by those within the art that, in general, terms used herein, and especially in the appended claims (*e.g.*, bodies of the appended claims) are generally intended as “open” terms (*e.g.*, the term “including” should be interpreted as “including but not limited to,” the term “having” should be interpreted as “having at least,” the term “includes” should be interpreted as “includes but is not limited to,” etc.). While various compositions, methods, and devices are described in terms of “comprising” various components or steps (interpreted as meaning “including, but not limited to”), the compositions, methods, and devices can also “consist essentially of” or “consist of” the various components and steps, and such terminology should be interpreted as defining essentially closed-member groups. It will be further understood by those within the art that if a specific number of an introduced claim recitation is intended, such an intent will be explicitly recited in the claim, and in the absence of such recitation no such intent is present. For example, as an aid to understanding, the following appended claims may contain usage of the introductory phrases “at least one” and “one or more” to introduce claim recitations. However, the use of such phrases should not be construed to imply that the introduction of a claim recitation by the indefinite articles “a” or “an” limits any particular claim containing such introduced claim recitation to embodiments containing only one such recitation, even when the same claim includes the introductory phrases “one or more” or “at least one” and indefinite articles such as “a” or “an” (*e.g.*, “a” and/or “an” should be interpreted to mean “at least one” or “one or more”); the same holds true for the use of definite articles used to introduce claim recitations. In addition, even if a specific number of an introduced claim

recitation is explicitly recited, those skilled in the art will recognize that such recitation should be interpreted to mean at least the recited number (*e.g.*, the bare recitation of “two recitations,” without other modifiers, means at least two recitations, or two or more recitations). Furthermore, in those instances where a convention analogous to “at least one of A, B, and C, etc.” is used, in general such a construction is intended in the sense one having skill in the art would understand the convention (*e.g.*, “a system having at least one of A, B, and C” would include but not be limited to systems that have A alone, B alone, C alone, A and B together, A and C together, B and C together, and/or A, B, and C together, etc.). In those instances where a convention analogous to “at least one of A, B, or C, etc.” is used, in general such a construction is intended in the sense one having skill in the art would understand the convention (*e.g.*, “a system having at least one of A, B, or C” would include but not be limited to systems that have A alone, B alone, C alone, A and B together, A and C together, B and C together, and/or A, B, and C together, etc.). It will be further understood by those within the art that virtually any disjunctive word and/or phrase presenting two or more alternative terms, whether in the description, claims, or drawings, should be understood to contemplate the possibilities of including one of the terms, either of the terms, or both terms. For example, the phrase “A or B” will be understood to include the possibilities of “A” or “B” or “A and B.”

**[0081]** In addition, where features or aspects of the disclosure are described in terms of Markush groups, those skilled in the art will recognize that the disclosure is also thereby described in terms of any individual member or subgroup of members of the Markush group.

**[0082]** As will be understood by one skilled in the art, for any and all purposes, such as in terms of providing a written description, all ranges disclosed herein also encompass any and all possible subranges and combinations of subranges thereof. Any listed range can be easily recognized as sufficiently describing and enabling the same range being broken down

into at least equal halves, thirds, quarters, fifths, tenths, etc. As a non-limiting example, each range discussed herein can be readily broken down into a lower third, middle third and upper third, etc. As will also be understood by one skilled in the art all language such as “up to,” “at least,” and the like include the number recited and refer to ranges which can be subsequently broken down into subranges as discussed above. Finally, as will be understood by one skilled in the art, a range includes each individual member. Thus, for example, a group having 1-3 cells refers to groups having 1, 2, or 3 cells. Similarly, a group having 1-5 cells refers to groups having 1, 2, 3, 4, or 5 cells, and so forth.

**[0083]** Various of the above-disclosed and other features and functions, or alternatives thereof, may be combined into many other different systems or applications. Various presently unforeseen or unanticipated alternatives, modifications, variations or improvements therein may be subsequently made by those skilled in the art, each of which is also intended to be encompassed by the disclosed embodiments.

## CLAIMS

*What Is Claimed Is:*

1. A device for treating a bone, the device comprising:  
a flexible tube having a distal end and a proximal end;  
a stiffening mechanism within the flexible tube configured to cause the flexible tube to become rigid; and  
an actuator configured to cause the stiffening mechanism to cause the flexible tube to become rigid in response to the actuator being actuated.
2. The device of claim 1, wherein the flexible tube comprises a series of slits configured to allow the tube to flex.
3. The device of claim 1, wherein the flexible tube comprises stainless steel, nitinol or a combination thereof.
4. The device of claim 1, further comprising a screw positioned at the distal end of the flexible tube.
5. The device of claim 1, wherein:  
the actuator comprises a cap connected to the proximal end of the flexible tube; and  
the cap is configured to permit the flexible tube to be rotated.
6. The device of claim 5, wherein:  
the stiffening mechanism comprises a plurality of expansion sleeves;

each of the plurality of expansions sleeves comprises a bore; and  
the cap is further configured to cause each of the plurality of expansion sleeves to abut an interior surface of the flexible tube in response to the cap being rotated.

7. The device of claim 6, wherein an expansion sleeve of the plurality of expansion sleeves comprises a spring.

8. The device of claim 6, wherein an expansion sleeve of the plurality of expansion sleeves comprises one or more jam nuts.

9. The device of claim 6, wherein an expansion sleeve of the plurality of expansion sleeves comprises one or more O-rings.

10. The device of claim 1, wherein:

the stiffening mechanism comprises a plurality of bead segments comprising a distal bead segment and a proximal bead segment;

each of the plurality of bead segments comprises a distal end, a proximal end and a bore;

the actuator comprises a cannula extending through the bore of each of the plurality of bead segments; and

the cannula has a distal end connected to the distal bead segment and a proximal end extending from the proximal end of the flexible tube.

11. The device of claim 10, wherein the cannula is configured to cause the proximal end of each bead segment to engage a distal end of an adjacent bead segment in response to the cannula being actuated.

12. The device of claim 10, wherein the distal end of each bead segment of the plurality of bead segments is shaped to receive the proximal end of an adjacent bead segment of the plurality of bead segments.

13. The device of claim 10, wherein the distal end of each bead segment of the plurality of bead segments is convex in shape and wherein the proximal end of each bead segment of the plurality of bead segments is concave in shape.

14. The device of claim 10, wherein one or more bead segments of the plurality of bead segments are about 8 mm in diameter.

15. The device of claim 10, wherein one or more bead segments of the plurality of bead segments are about 2 mm to about 15 mm in diameter.

16. The device of claim 10, wherein one or more bead segments of the plurality of bead segments are about 12 mm in length.

17. The device of claim 10, wherein one or more bead segments of the plurality of bead segments are about 5 mm to about 25 mm in length.

18. The device of claim 1, wherein:  
the stiffening mechanism comprises a plurality of expansion sleeves;  
each of the plurality of expansions sleeves comprises a bore;  
the actuator comprises a cannula extending through the bore of each of the plurality of expansion sleeves; and  
the cannula is configured to cause each of the plurality of expansion sleeves to abut an interior surface of the flexible tube in response to the cannula being actuated.
19. The device of claim 18, wherein an expansion sleeve of the plurality of expansion sleeves comprises a spring.
20. The device of claim 18, wherein an expansion sleeve of the plurality of expansion sleeves comprises one or more jam nuts.
21. The device of claim 18, wherein an expansion sleeve of the plurality of expansion sleeves comprises one or more O-rings.
22. A method of treating a bone, the method comprising:  
inserting a guide wire into an intramedullary space of the bone, wherein the guide wire comprises a bent section having a sharpened tip at a distal portion of the guide wire;  
forming a tunnel surrounding the guide wire in the bone;  
inserting a flexible device into the tunnel; and  
causing the flexible device to become rigid in the tunnel in order to fix a fracture of the bone.

23. The method of claim 22, wherein the bone comprises a curved bone.
24. The method of claim 22, wherein the bone comprises at least a portion of a pelvic ring.
25. The method of claim 22, wherein the bone comprises at least a portion of a posterior column or an anterior column of an acetabulum.
26. The method of claim 22, wherein the guide wire comprises stainless steel, nitinol or a combination thereof.
27. The method of claim 22, wherein the guide wire is about 1 mm to about 1.5 mm in diameter.
28. The method of claim 22, wherein inserting a guide wire comprises:
  - rotating the guide wire to orient the bent section of the guide wire; and
  - selectively hammering the guide wire to cause the bent section to form a curved path in the bone based on the orientation of the bent section.
29. The method of claim 28, wherein inserting a guide wire comprises using a fluoroscope to determine the orientation of the bent section of the guide wire.
30. The method of claim 22, wherein:
  - forming a tunnel comprises forming the tunnel using a cannulated reamer with a flexible drive shaft; and

the cannulated reamer comprises a bore to receive the guide wire.

31. The method of claim 22, wherein causing the flexible device to become rigid comprises:

operating an actuator; and

in response to operating the actuator, rigidizing the flexible device from a flexible state to a more rigid state.

32. The method of claim 22, wherein causing the flexible device to become rigid comprises:

operating an actuator; and

in response to operating the actuator, causing each of a plurality of expansion sleeves to abut an interior surface of the flexible device.

33. The method of claim 32, wherein an expansion sleeve of the plurality of expansion sleeves comprises a spring.

34. The method of claim 32, wherein an expansion sleeve of the plurality of expansion sleeves comprises one or more jam nuts.

35. The method of claim 32, wherein an expansion sleeve of the plurality of expansion sleeves comprises one or more O-rings.

36. The method of claim 32, wherein causing the flexible device to become rigid comprises actuating a cannula extending through each of the plurality of expansion sleeves.
37. The method of claim 22, wherein the causing the flexible device to become rigid comprises rotating a cap located at a proximal end of the flexible device.
38. A device for treating a bone, the device comprising:  
a flexible tube having a distal end and a proximal end;  
a plurality of rods contained within the flexible tube; and  
an actuator configured to cause the plurality of rods to be fixed in place when actuated.
39. The device of claim 38, wherein the flexible tube comprises a series of slits configured to allow the tube to flex.
40. The device of claim 38, wherein the flexible tube comprises stainless steel, nitinol or a combination thereof.
41. The device of claim 38, further comprising a screw positioned at the distal end of the flexible tube.
42. The device of claim 38, wherein the plurality of rods are affixed to each other at the distal end of the flexible tube.

43. The device of claim 42, wherein the actuator is configured to cause the plurality of rods to be fixed by causing the plurality of rods to lock in place at the proximal end of the flexible tube.
44. The device of claim 38, further comprising a sleeve located within the flexible tube and containing the plurality of rods.
45. The device of claim 44, wherein the actuator is configured to cause the plurality of rods to be fixed by causing the sleeve to apply a normal force towards a center of the sleeve in response to the actuator being actuated.
46. A device for treating a bone, the device comprising:  
a flexible tube having a distal end and a proximal end;  
a spring contained within the flexible tube; and  
an actuator configured to cause the spring to exert a normal force against an inner surface of the flexible tube in response to the actuator being actuated.
47. The device of claim 46, wherein the flexible tube comprises a series of slits configured to allow the tube to flex.
48. The device of claim 46, wherein the flexible tube comprises stainless steel, nitinol or a combination thereof.

49. The device of claim 46, further comprising a screw positioned at the distal end of the flexible tube.

50. A kit comprising:

a flexible device comprising a flexible tube having a distal end and a proximal end, a stiffening mechanism within the flexible tube, and an actuator configured to cause the stiffening mechanism to cause the flexible tube to become rigid in response to the actuator being actuated; and

instructions for using the flexible device to fix a bone fracture.

51. The kit of claim 50, further comprising:

a hammer drill; and

a guide wire configured to be attached to the hammer drill, wherein the guide wire comprises a bent section having a sharpened tip at a distal portion of the guide wire.

52. The kit of claim 50, further comprising:

a hammer drill;

a guide wire configured to be attached to the hammer drill, wherein the guide wire comprises a bent section having a sharpened tip at a distal portion of the guide wire; and

a cannulated reamer with a flexible drive shaft, wherein the cannulated reamer comprises a bore to receive the guide wire.

53. The kit of claim 50, wherein the stiffening mechanism of the flexible device comprises a spring.

54. The kit of claim 50, wherein the stiffening mechanism of the flexible device comprises one or more jam nuts.
55. The kit of claim 50, wherein the stiffening mechanism of the flexible device comprises one or more O-rings.
56. The kit of claim 50, wherein the stiffening mechanism of the flexible device comprises a plurality of bead segments.
57. The kit of claim 50, wherein the stiffening mechanism of the flexible device comprises a plurality of rods, wherein each rod is connected to the distal end of the flexible tube.
58. The kit of claim 50, wherein the actuator of the flexible device comprises a cap located at the proximal end of the flexible tube.
59. The kit of claim 50, wherein the actuator of the flexible device comprises a cannula connected to the distal end of the flexible tube and extending from the proximal end of the flexible tube.
60. A device for treating a bone, the device comprising:  
a flexible tube having a distal end and a proximal end, wherein the flexible tube comprises a series of slits configured to allow the flexible tube to flex;  
a screw positioned at the distal end of the flexible tube;

a plurality of bead segments within the flexible tube configured to cause the flexible tube to become rigid, wherein the plurality of bead segments comprise a distal bead segment and a proximal bead segment, wherein each of the plurality of bead segments comprises a distal end, a proximal end and a bore;

a cannula extending through the bore of each of the plurality of bead segments, wherein the cannula has a distal end connected to the distal bead segment and a proximal end extending from the proximal end of the flexible tube; and

a cap connected to the proximal end of the flexible tube, wherein the cap is configured to permit the flexible tube to be rotated.

61. The device of claim 60, wherein the cannula is configured to cause the proximal end of each bead segment to engage a distal end of an adjacent bead segment in response to the cannula being actuated.

62. The device of claim 60, wherein the distal end of each bead segment of the plurality of bead segments is shaped to receive the proximal end of an adjacent bead segment of the plurality of bead segments.

63. The device of claim 60, wherein the distal end of each bead segment of the plurality of bead segments is convex in shape and wherein the proximal end of each bead segment of the plurality of bead segments is concave in shape.

64. The device of claim 60, wherein one or more bead segments of the plurality of bead segments are about 8 mm in diameter.

65. The device of claim 60, wherein one or more bead segments of the plurality of bead segments are about 2 mm to about 15 mm in diameter.

66. The device of claim 60, wherein one or more bead segments of the plurality of bead segments are about 12 mm in length.

67. The device of claim 60, wherein one or more bead segments of the plurality of bead segments are about 5 mm to about 25 mm in length.

68. A bone containing a device for treating the bone, wherein the device comprises:  
a tube having a distal end and a proximal end;  
a stiffening mechanism configured to cause the tube to remain in a rigid state.

69. The device of claim 68, further comprising a screw positioned at the distal end of the tube.

70. The device of claim 68, wherein:  
the stiffening mechanism comprises a plurality of bead segments comprising a distal bead segment; and  
each of the plurality of bead segments comprises a distal end and a proximal end.

71. The device of claim 70, wherein the distal end of each bead segment of the plurality of bead segments, other than the distal bead segment, receives the proximal end of an adjacent bead segment of the plurality of bead segments.

72. The device of claim 70, wherein one or more bead segments of the plurality of bead segments are about 8 mm in diameter.

73. The device of claim 70, wherein one or more bead segments of the plurality of bead segments are about 2 mm to about 15 mm in diameter.

74. The device of claim 70, wherein one or more bead segments of the plurality of bead segments are about 12 mm in length.

75. The device of claim 70, wherein one or more bead segments of the plurality of bead segments are about 5 mm to about 25 mm in length.

76. The device of claim 68, wherein the stiffening mechanism comprises a plurality of expansion sleeves.

77. The device of claim 76, wherein an expansion sleeve of the plurality of expansion sleeves comprises a spring.

78. The device of claim 76, wherein an expansion sleeve of the plurality of expansion sleeves comprises one or more jam nuts.

79. The device of claim 76, wherein an expansion sleeve of the plurality of expansion sleeves comprises one or more O-rings.

80. A device for treating a bone, the device comprising:

- a plurality of bead segments comprising a distal bead segment and a proximal bead segment, wherein each of the plurality of bead segments comprises a distal end, a proximal end and a bore;
- a screw head in contact with a distal end of the distal bead segment,
- a stiffening cable extending through the bore of each of the plurality of bead segments; and
- a tensioning assembly in contact with a proximal end of the proximal bead segment, wherein the tensioning assembly is configured to cause the stiffening cable to cause the proximal end of each bead segment to engage a distal end of an adjacent bead segment, wherein the stiffening cable has a distal end connected to the screw head and a proximal end connected to the tensioning assembly.

81. The device of claim 80, wherein the distal end of each bead segment of the plurality of bead segments is shaped to receive the proximal end of an adjacent bead segment of the plurality of bead segments.

82. The device of claim 80, wherein the distal end of each bead segment of the plurality of bead segments is convex in shape and wherein the proximal end of each bead segment of the plurality of bead segments is concave in shape.

83. The device of claim 80, wherein the distal end of each bead segment has one of a square cross-section, a pentagonal cross-section, a hexagonal cross-section, a heptagonal cross-section and an octagonal cross-section.

84. The device of claim 80, wherein the proximal end of each bead segment has an interior surface that includes one or more of a square cross-section, a pentagonal cross-section, a hexagonal cross-section, a heptagonal cross-section, an octagonal cross-section, a spherical cross-section, and a conical cross-section.

85. The device of claim 80, wherein the proximal end of each bead segment has an interior surface having a spherical cross-section at a proximal portion and a conical cross-section at a distal portion.

86. The device of claim 80, wherein one or more bead segments of the plurality of bead segments are about 8 mm in diameter.

87. The device of claim 80, wherein one or more bead segments of the plurality of bead segments are about 2 mm to about 15 mm in diameter.

88. The device of claim 80, wherein one or more bead segments of the plurality of bead segments are about 12 mm in length.

89. The device of claim 80, wherein one or more bead segments of the plurality of bead segments are about 5 mm to about 25 mm in length.

90. The device of claim 80, wherein the tensioning assembly comprises:  
a hex ball tensioner at a distal end of the tensioning assembly, wherein the hex ball tensioner is configured to engage with the proximal end of the proximal bead segment;  
a cable anchor configured to anchor the stiffening cable;

a tensioning sleeve configured to be threaded over the cable anchor in order to cause the stiffening cable to cause the plurality of bead segments to engage; and

a lock nut configured to lock the tensioning assembly to a bone.

91. The device of claim 90, further comprising:

a collet within the cable anchor configured to secure the stiffening cable.

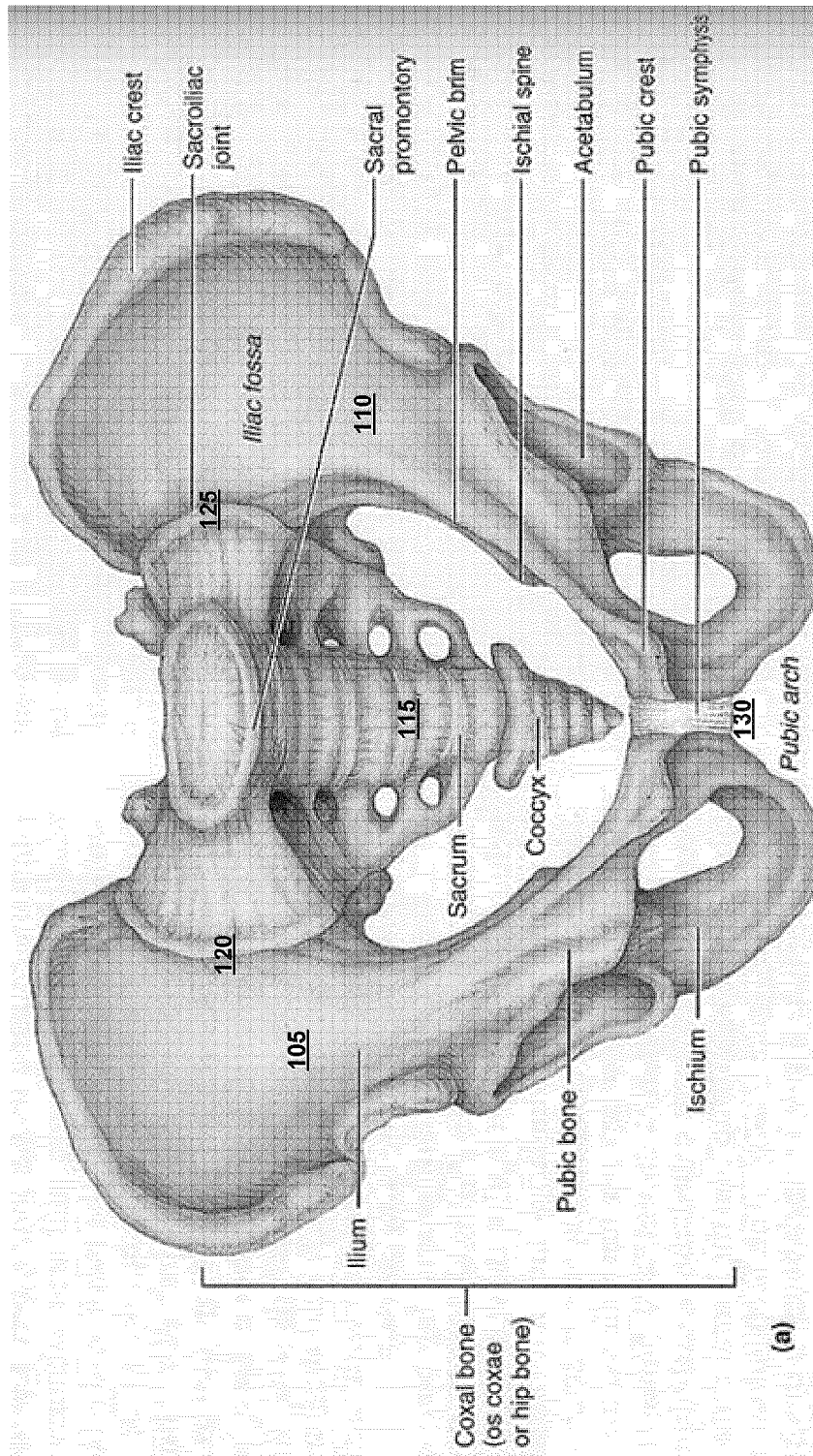

FIG. 1A

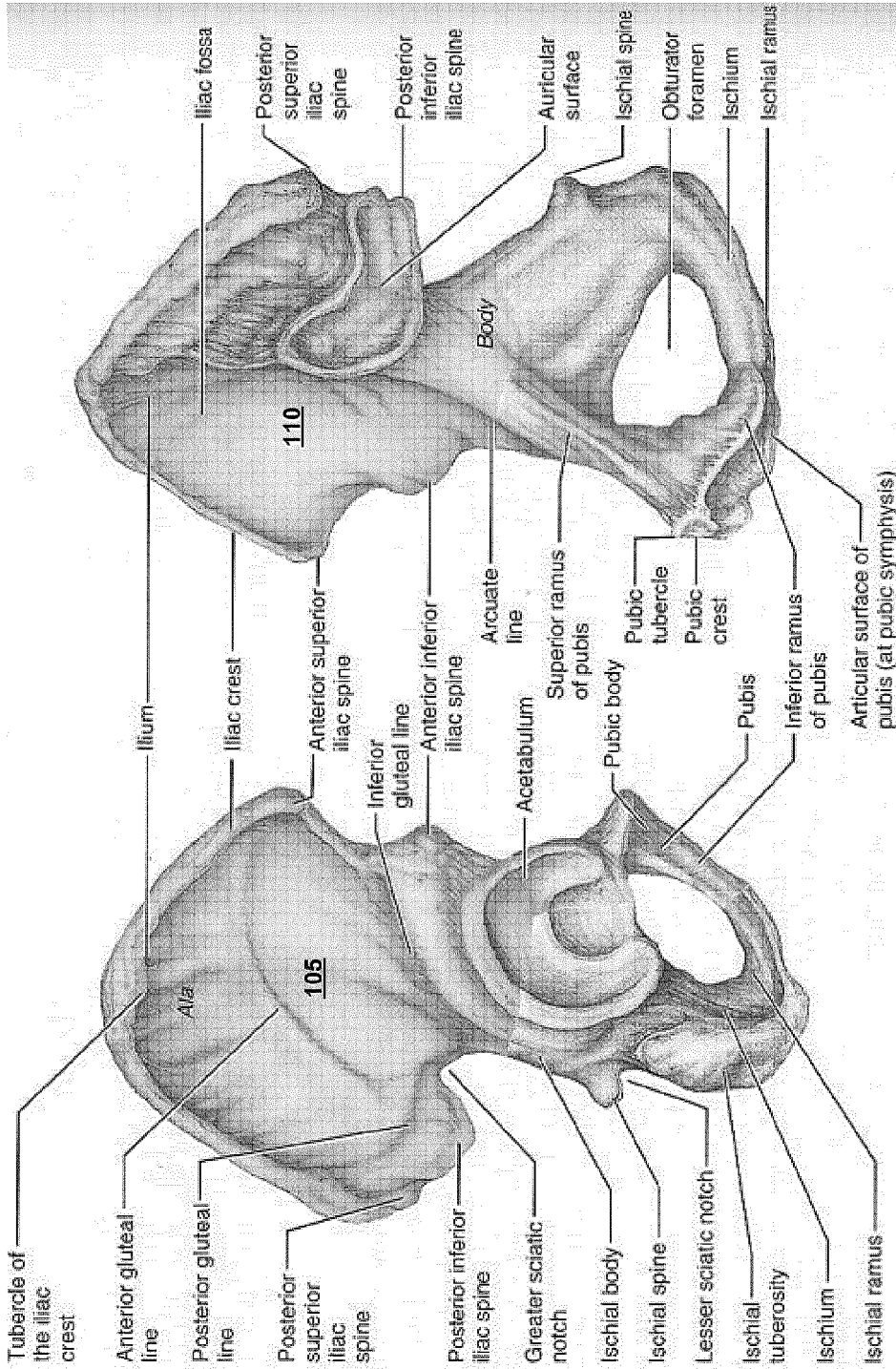

FIG. 1B

FIG. 1C

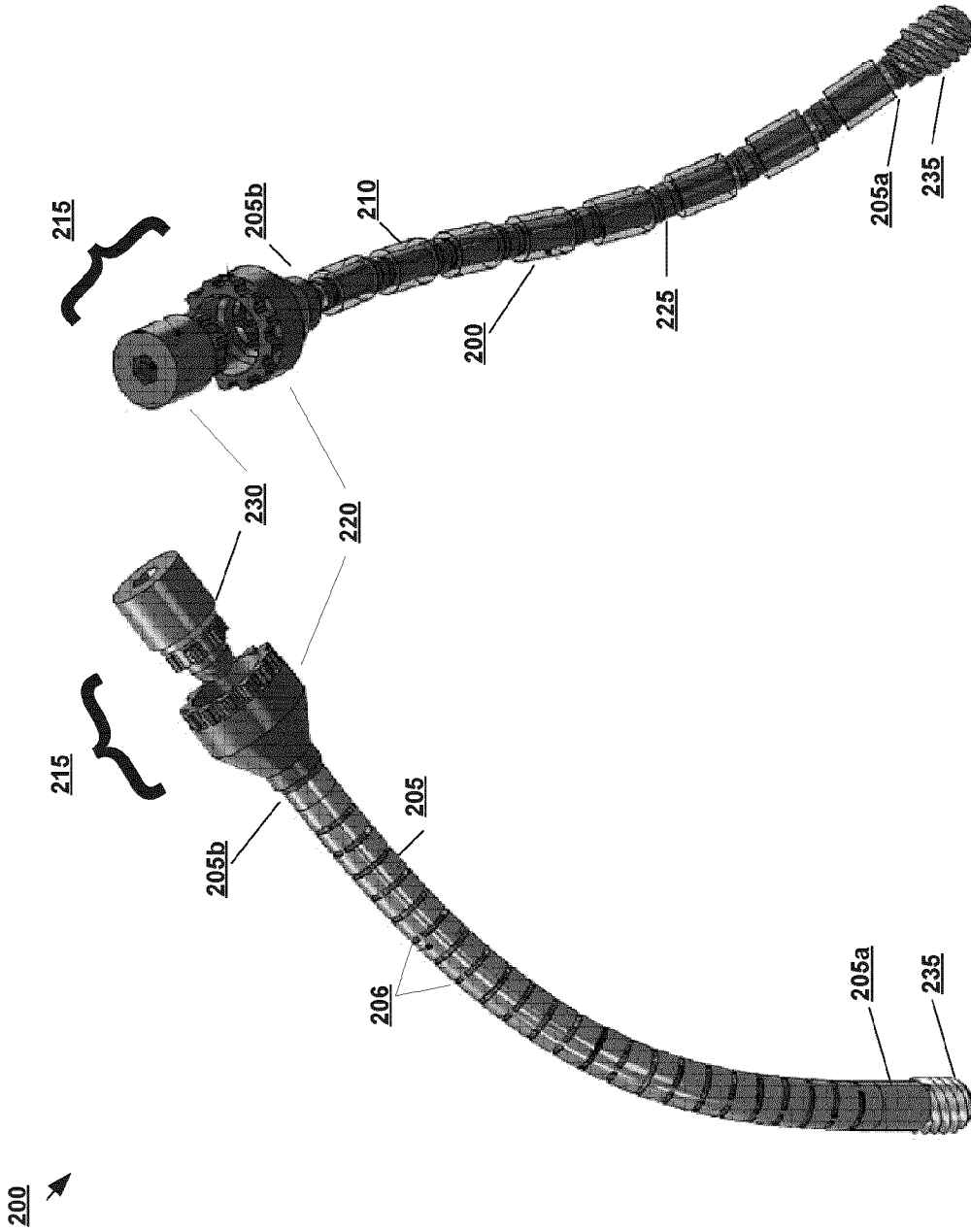

FIG. 2B

FIG. 2A

4/13

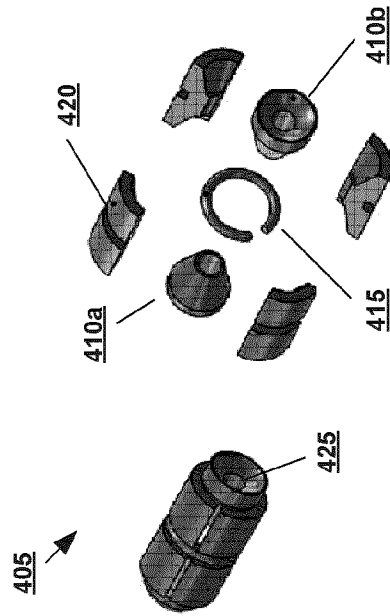

FIG. 4

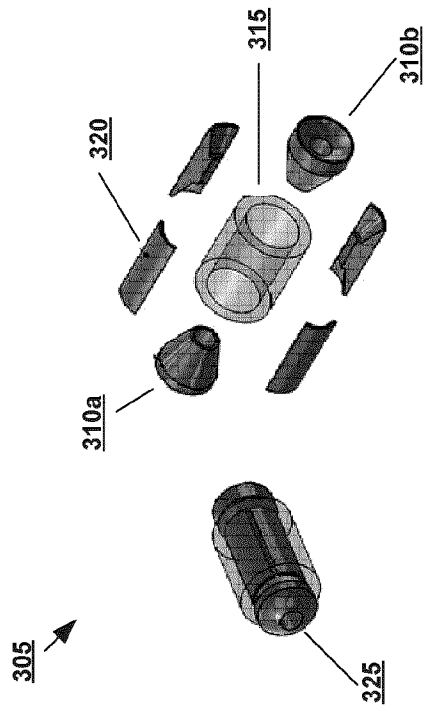

FIG. 3

5/13

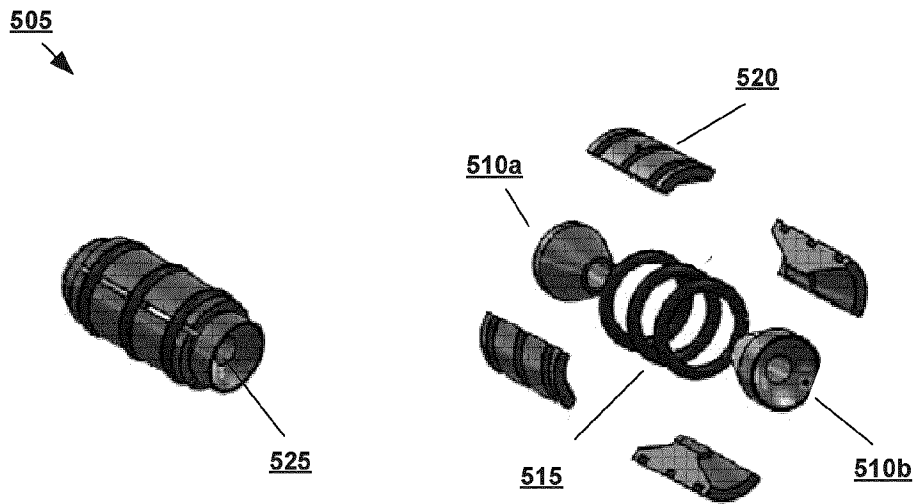

FIG. 5

6/13

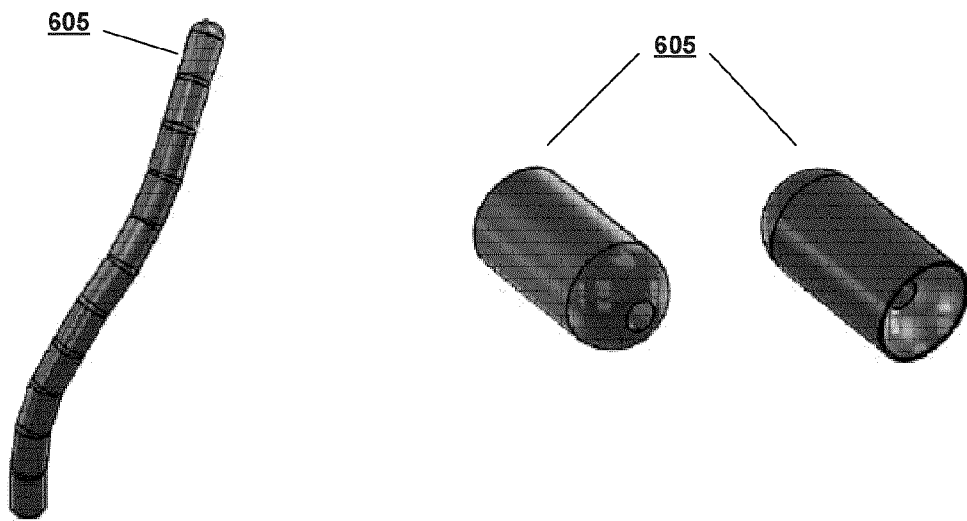

FIG. 6

7/13

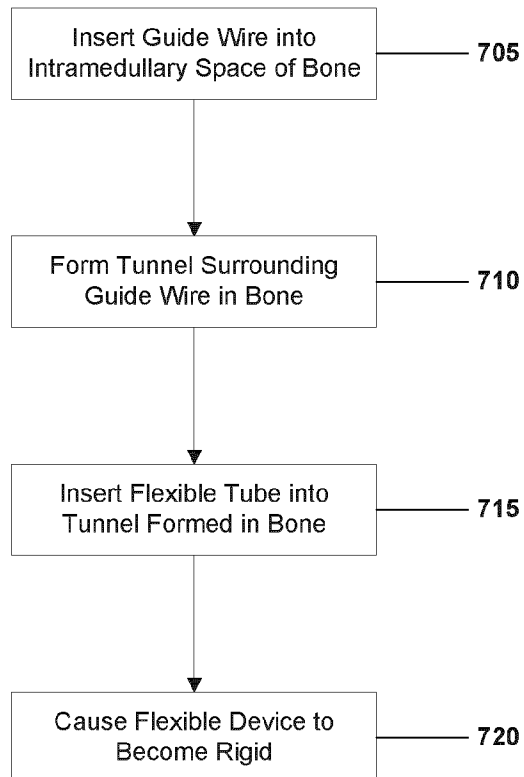

FIG. 7

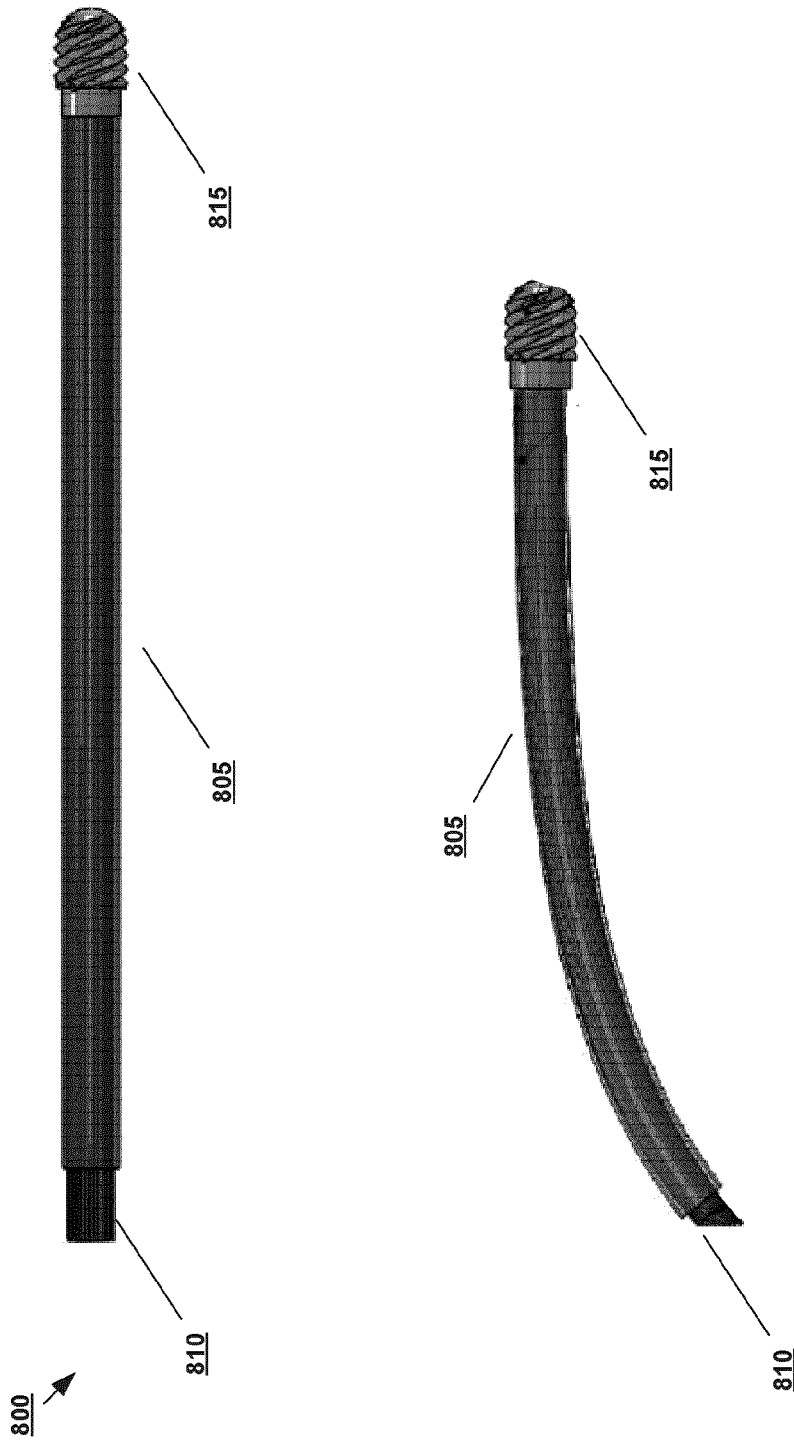
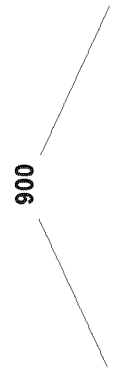
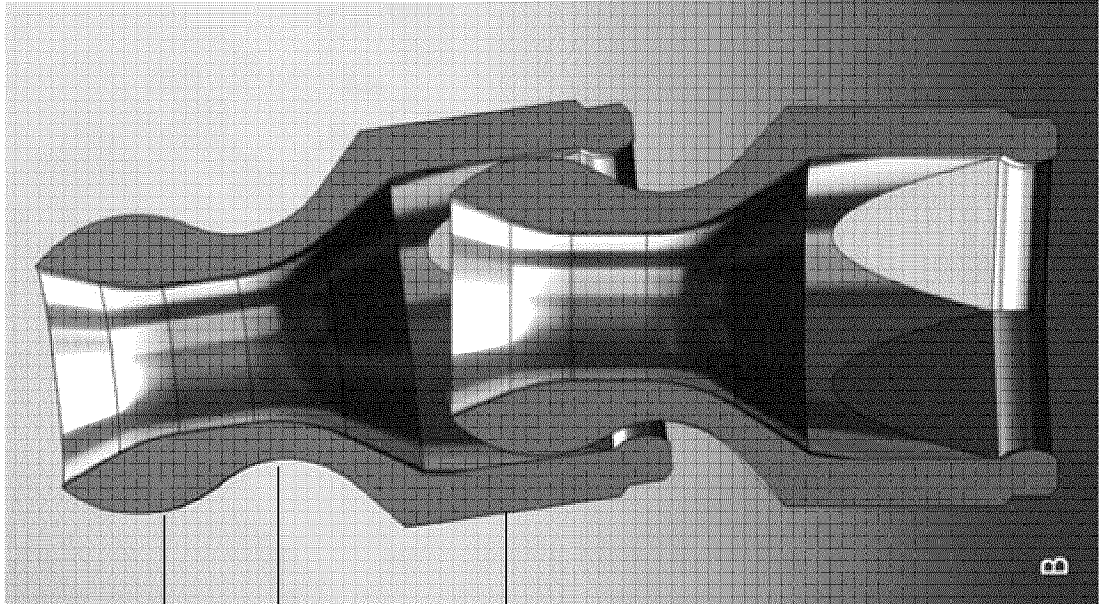

FIG. 8



905

915

910

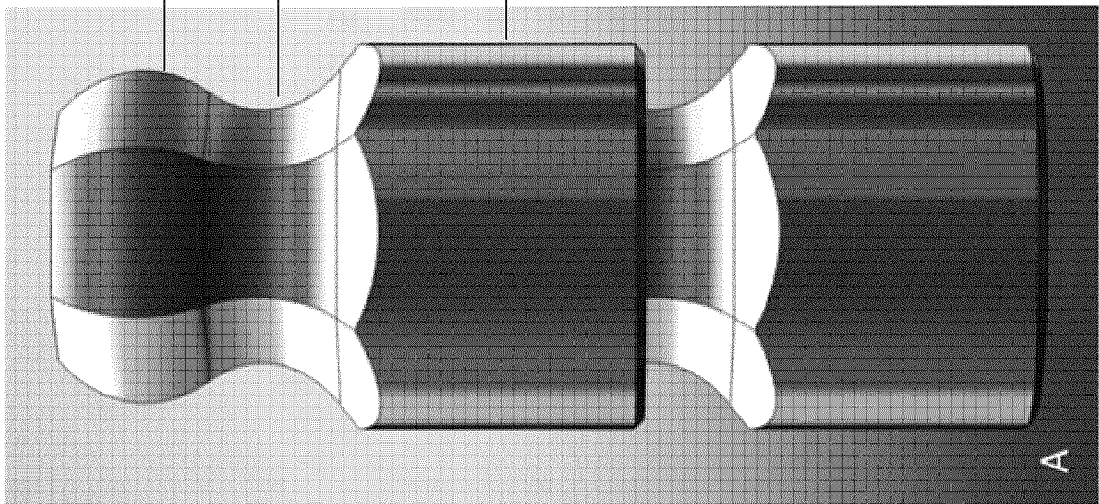

FIG. 9A

FIG. 9B

FIG. 10A

FIG. 10B

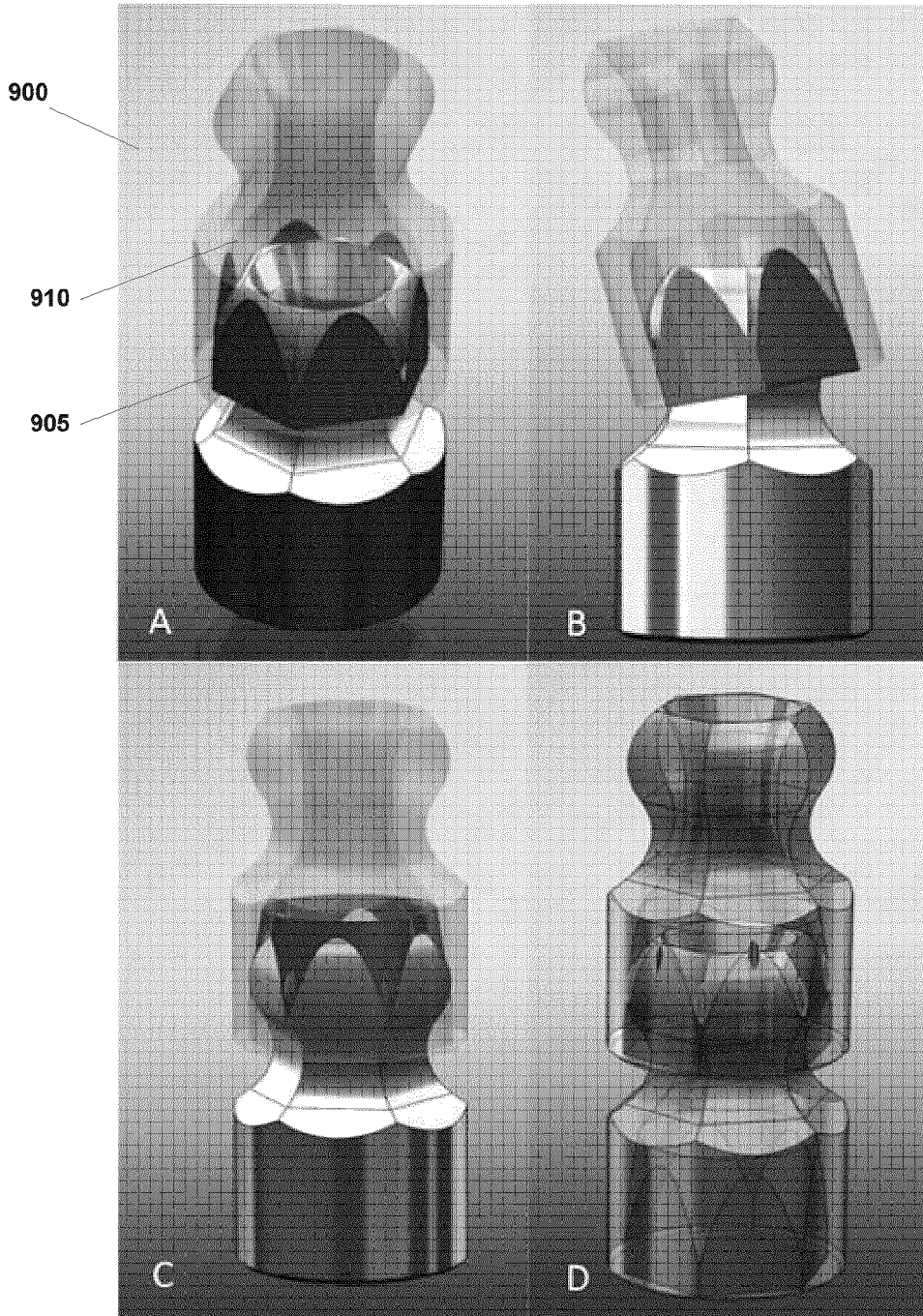

FIG. 10C

FIG. 10D

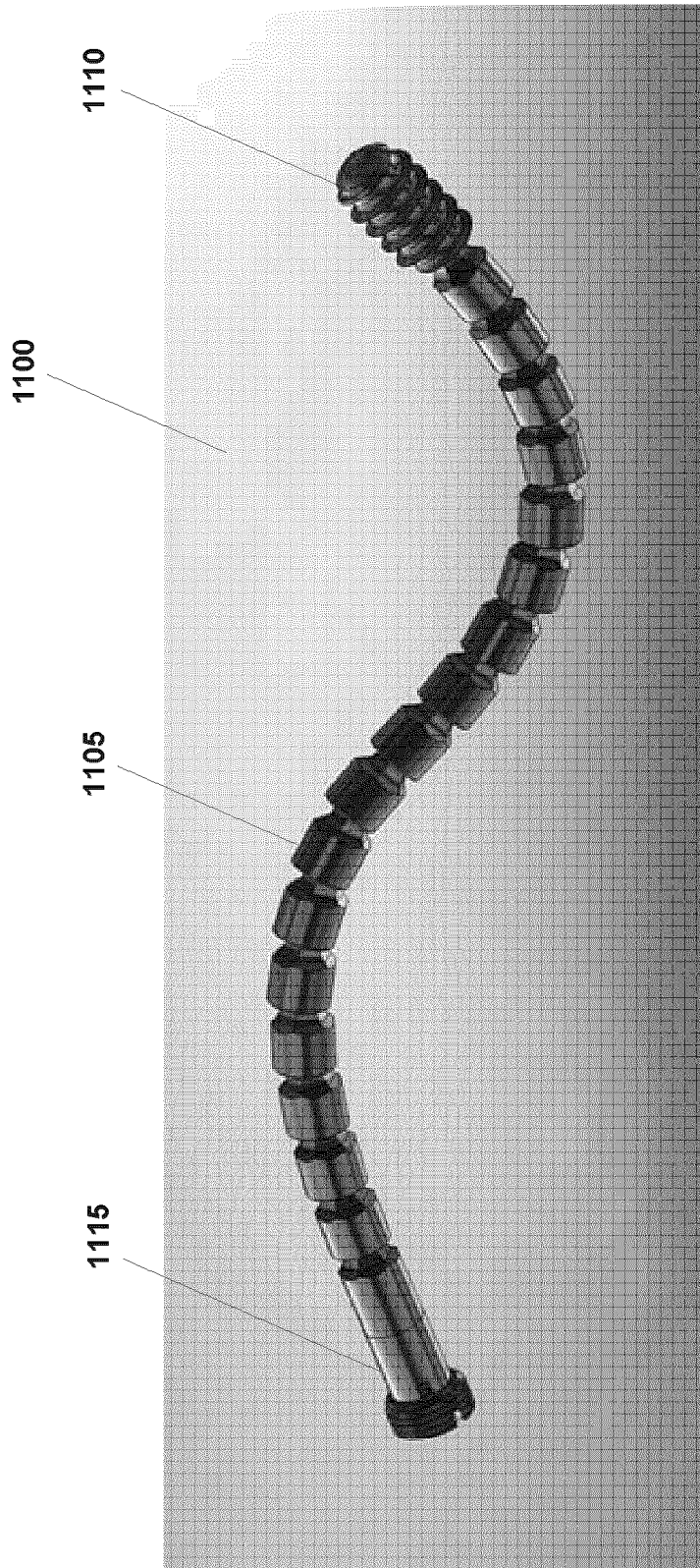

FIG. 11

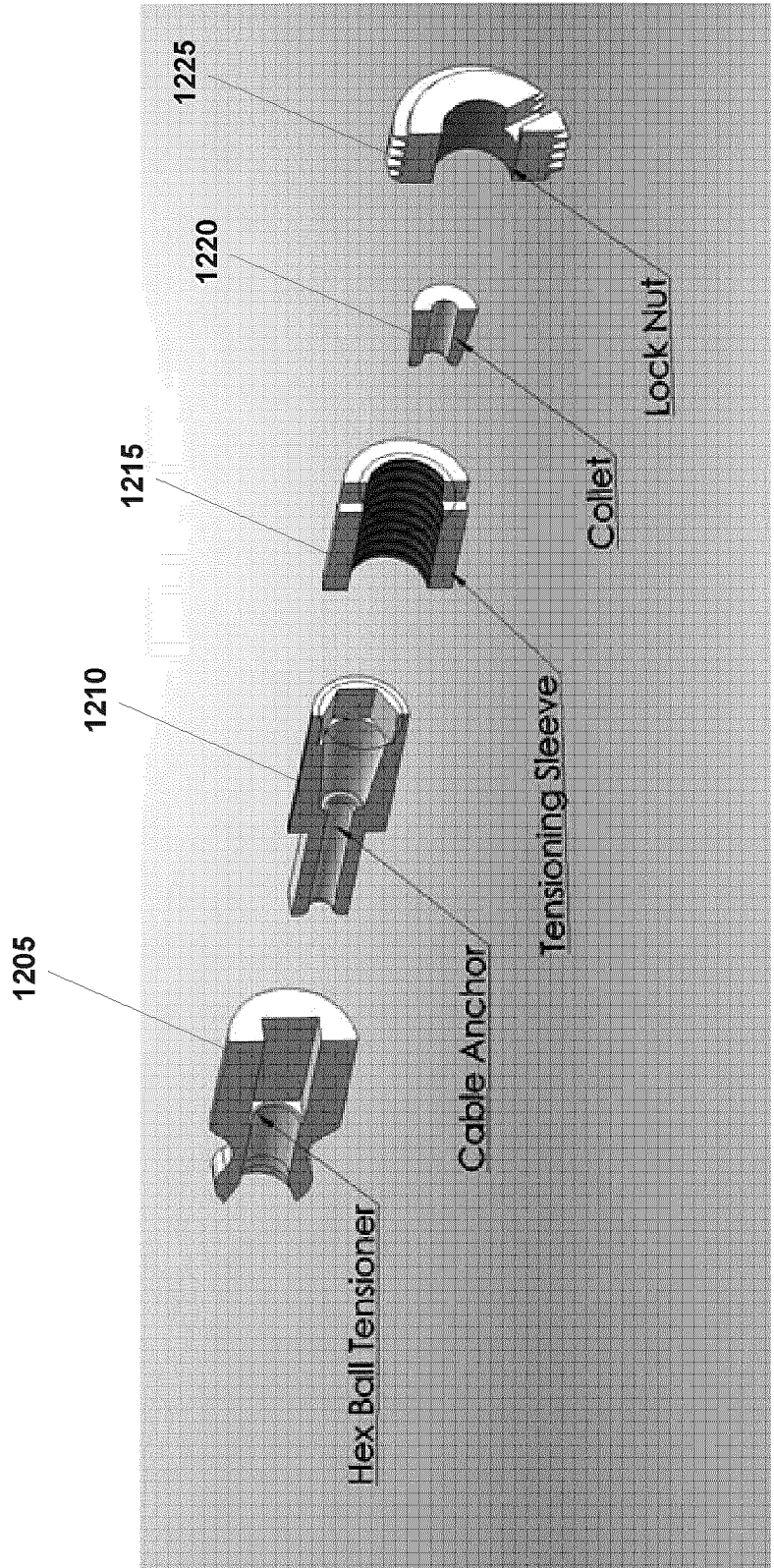

FIG. 12A

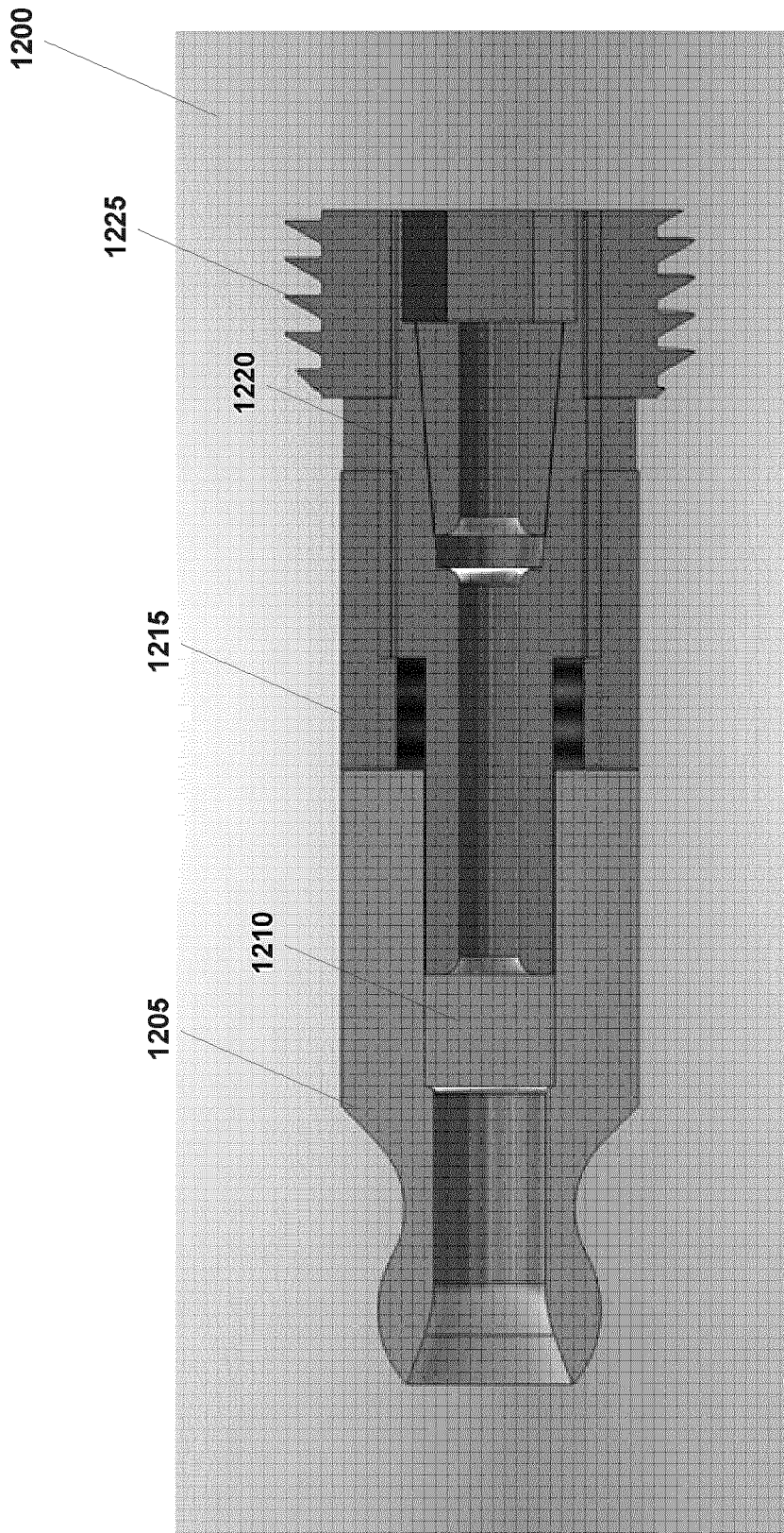

FIG. 12B

**INTERNATIONAL SEARCH REPORT**

International application No.  
PCT/CA2012/050808

<p>A. CLASSIFICATION OF SUBJECT MATTER                  IPC: <b>A61B 17/88</b> (2006.01) , <b>A61B 17/17</b> (2006.01) , <b>A61B 17/72</b> (2006.01) , <b>A61B 17/92</b> (2006.01) ,  <b>B23B 41/00</b> (2006.01) , <b>B23B 45/16</b> (2006.01)                  According to International Patent Classification (IPC) or to both national classification and IPC</p>		
<p>B. FIELDS SEARCHED</p>		
<p>Minimum documentation searched (classification system followed by classification symbols)                  A61B 17/68; 17/88; 17/17; 17/72; 17/92; B23B 41/00; 45/16; A61B</p>		
<p>Documentation searched other than minimum documentation to the extent that such documents are included in the fields searched</p>		
<p>Electronic database(s) consulted during the international search (name of database(s) and, where practicable, search terms used)                  EPOQUE (EPODOC) pelvic ring, pelvis ring, treat+, fracture, bone, flexible, rigid+, hard; stiff+; spring; intramedullary, intramedular, flexible tube, etc.</p>		
<p>C. DOCUMENTS CONSIDERED TO BE RELEVANT</p>		
<b>Category*</b>	<b>Citation of document, with indication, where appropriate, of the relevant passages</b>	<b>Relevant to claim No.</b>
X Y	US 5944719A (LEBAN, S.) 31 August 1999 (31-08-1999) *Entire document*	1, 2, 5, 10, 11, 12, 3, 4, 50, 59-67, 80, 81, 86-89
X Y	US 20080269745A1 (JUSTIN, D. F.) 30 October 2008 (30-10-2008) *Par. [0048], [0056]-[0058], [0071]-[0072], [0085]-[0089]; Figs. 5, 7, 13A-13B, 17-21*	1, 38, 42 3, 4, 40, 41, 44, 50, 57- 59
Y	US 5601550A (ESSER, R. D.) 11 February 1997 (11-02-1997) *Col. 4, lines 30-36, claims 10-15; Figs. 2-3*	4
A	US20110144645A1 (SARAVIA, H. et al.) 16 June 2011 (16-06-2011) *Entire document*	
A	US 5527310A (COLE, J. D.) 18 June 1996 (18-06-1996) *Entire document*	
A	US20130006245A1 (STONEBURNER, J. D. et al.) 3 January 2013 (03-01-2013) *Entire document*	
<p><input type="checkbox"/> Further documents are listed in the continuation of Box C.</p>		<p><input checked="" type="checkbox"/> See patent family annex.</p>
*	Special categories of cited documents :	<p>"T" later document published after the international filing date or priority date and not in conflict with the application but cited to understand the principle or theory underlying the invention</p> <p>"X" document of particular relevance; the claimed invention cannot be considered novel or cannot be considered to involve an inventive step when the document is taken alone</p> <p>"Y" document of particular relevance; the claimed invention cannot be considered to involve an inventive step when the document is combined with one or more other such documents, such combination being obvious to a person skilled in the art</p> <p>"&amp;" document member of the same patent family</p>
"A"	document defining the general state of the art which is not considered to be of particular relevance	
"E"	earlier application or patent but published on or after the international filing date	
"L"	document which may throw doubts on priority claim(s) or which is cited to establish the publication date of another citation or other special reason (as specified)	
"O"	document referring to an oral disclosure, use, exhibition or other means	
"P"	document published prior to the international filing date but later than the priority date claimed	
<p>Date of the actual completion of the international search                  29 January 2013 (29-01-2013)</p>		<p>Date of mailing of the international search report                  26 February 2013 (26-02-2013)</p>
<p>Name and mailing address of the ISA/CA                  Canadian Intellectual Property Office                  Place du Portage I, C114 - 1st Floor, Box PCT                  50 Victoria Street                  Gatineau, Quebec K1A 0C9                  Facsimile No.: 001-819-953-2476</p>		<p>Authorized officer   <b>Daniel Cormier (819) 997-2754</b></p>

**Box No. II Observations where certain claims were found unsearchable (Continuation of item 2 of the first sheet)**

This international search report has not been established in respect of certain claims under Article 17(2)(a) for the following reasons :

1.  Claim Nos. : 22-37 and 68-79  
because they relate to subject matter not required to be searched by this Authority, namely :  
  
claims 22-37 are directed to a method for treatment of the human or animal body by surgery and claims 68-79 are directed to a human or animal body part ("A bone containing a device for treating the bone"). The International Search Authority is not required to search the subject matter of these claims.
2.  Claim Nos. :  
because they relate to parts of the international application that do not comply with the prescribed requirements to such an extent that no meaningful international search can be carried out, specifically :
3.  Claim Nos. :  
because they are dependent claims and are not drafted in accordance with the second and third sentences of Rule 6.4(a).

**Box No. III Observations where unity of invention is lacking (Continuation of item 3 of first sheet)**

This International Searching Authority found multiple inventions in this international application, as follows :

1.  As all required additional search fees were timely paid by the applicant, this international search report covers all searchable claims.
2.  As all searchable claims could be searched without effort justifying additional fees, this Authority did not invite payment of additional fees.
3.  As only some of the required additional search fees were timely paid by the applicant, this international search report covers only those claims for which fees were paid, specifically claim Nos. :
4.  No required additional search fees were timely paid by the applicant. Consequently, this international search report is restricted to the invention first mentioned in the claims; it is covered by claim Nos. :

- Remark on Protest**  The additional search fees were accompanied by the applicant's protest and, where applicable, the payment of a protest fee.
- The additional search fees were accompanied by the applicant's protest but the applicable protest fee was not paid within the time limit specified in the invitation.
- No protest accompanied the payment of additional search fees.

**INTERNATIONAL SEARCH REPORT**  
Information on patent family members

International application No.  
PCT/CA2012/050808

Patent Document Cited in Search Report	Publication Date	Patent Family Member(s)	Publication Date
US5944719A	31 August 1999 (31-08-1999)	None	
US2008269745A1	30 October 2008 (30-10-2008)	CA2685046A1 EP2139432A2 JP2010524642A US2008269747A1 US8128626B2 US2008269776A1 US8147492B2 US2008269748A1 US8162943B2 US2008269750A1 US8167881B2 US2008269746A1 US2008269749A1 US2012239037A1 WO2008134287A2 WO2008134287A3	06 November 2008 (06-11-2008) 06 January 2010 (06-01-2010) 22 July 2010 (22-07-2010) 30 October 2008 (30-10-2008) 06 March 2012 (06-03-2012) 30 October 2008 (30-10-2008) 03 April 2012 (03-04-2012) 30 October 2008 (30-10-2008) 24 April 2012 (24-04-2012) 30 October 2008 (30-10-2008) 01 May 2012 (01-05-2012) 30 October 2008 (30-10-2008) 30 October 2008 (30-10-2008) 20 September 2012 (20-09-2012) 06 November 2008 (06-11-2008) 22 January 2009 (22-01-2009)
US5601550A	11 February 1997 (11-02-1997)	None	
US2011144645A1	16 June 2011 (16-06-2011)	AU2006247498A1 AU2007323566A1 AU2007323567A1 AU2007323570A1 AU2009257472A1 AU2009296243A1 CA2608693A1 CA2669737A1 CA2670263A1 CA2670438A1 CA2727453A1 CA2738478A1 CN101208053A EP1885263A1 EP2094163A2 EP2094177A2 EP2299917A1 EP2341857A2 JP2008540037A JP2010510040A JP2010510041A JP2010510042A JP2011523889A JP2012504027A US2006264950A1 US7846162B2 US2008161805A1 US7909825B2 US2007233105A1 US7914533B2 US2006264952A1 US7942875B2 US2010094347A1 US8287539B2 US2010023010A1 US8287541B2	23 November 2006 (23-11-2006) 29 May 2008 (29-05-2008) 29 May 2008 (29-05-2008) 29 May 2008 (29-05-2008) 17 December 2009 (17-12-2009) 01 April 2010 (01-04-2010) 23 November 2006 (23-11-2006) 29 May 2008 (29-05-2008) 29 May 2008 (29-05-2008) 29 May 2008 (29-05-2008) 17 December 2009 (17-12-2009) 01 April 2010 (01-04-2010) 25 June 2008 (25-06-2008) 13 February 2008 (13-02-2008) 02 September 2009 (02-09-2009) 02 September 2009 (02-09-2009) 30 March 2011 (30-03-2011) 13 July 2011 (13-07-2011) 20 November 2008 (20-11-2008) 02 April 2010 (02-04-2010) 02 April 2010 (02-04-2010) 02 April 2010 (02-04-2010) 25 August 2011 (25-08-2011) 16 February 2012 (16-02-2012) 23 November 2006 (23-11-2006) 07 December 2010 (07-12-2010) 03 July 2008 (03-07-2008) 22 March 2011 (22-03-2011) 04 October 2007 (04-10-2007) 29 March 2011 (29-03-2011) 23 November 2006 (23-11-2006) 17 May 2011 (17-05-2011) 15 April 2010 (15-04-2010) 16 October 2012 (16-10-2012) 28 January 2010 (28-01-2010) 16 October 2012 (16-10-2012)

[continued on page 5]]

## INTERNATIONAL SEARCH REPORT

International application No.  
PCT/CA2012/050808

[continuation of Information on Patent Family Members]

	US2006264951A1	23 November 2006 (23-11-2006)	
	US2008132896A1	05 June 2008 (05-06-2008)	
	US2008140078A1	12 June 2008 (12-06-2008)	
	US2009018542A1	15 January 2009 (15-01-2009)	
	US2011087227A1	14 April 2011 (14-04-2011)	
	US2011282346A1	17 November 2011 (17-11-2011)	
	US2012239038A1	20 September 2012 (20-09-2012)	
	US2013012942A1	10 January 2013 (10-01-2013)	
	WO2006124764A1	23 November 2006 (23-11-2006)	
	WO2008064346A2	29 May 2008 (29-05-2008)	
	WO2008064346A9	09 October 2008 (09-10-2008)	
	WO2008064346A3	11 December 2008 (11-12-2008)	
	WO2008064347A2	29 May 2008 (29-05-2008)	
	WO2008064347A3	04 December 2008 (04-12-2008)	
	WO2008064350A2	29 May 2008 (29-05-2008)	
	WO2008064350A3	20 November 2008 (20-11-2008)	
	WO2009009772A1	15 January 2009 (15-01-2009)	
	WO2009152270A1	17 December 2009 (17-12-2009)	
	WO2009152272A1	17 December 2009 (17-12-2009)	
	WO2009152273A1	17 December 2009 (17-12-2009)	
	WO2010037038A2	01 April 2010 (01-04-2010)	
	WO2010037038A9	27 May 2010 (27-05-2010)	
	WO2010037038A3	15 July 2010 (15-07-2010)	
	WO2010062379A1	03 June 2010 (03-06-2010)	
US5527310A	18 June 1996 (18-06-1996)	None	
US2013006245A1	03 January 2013 (03-01-2013)	AU2008228710A1	25 September 2008 (25-09-2008)
		CA2678911A1	25 September 2008 (25-09-2008)
		CA2725324A1	26 November 2009 (26-11-2009)
		CN101636119A	27 January 2010 (27-01-2010)
		EP2129309A2	09 December 2009 (09-12-2009)
		EP2309937A2	20 April 2011 (20-04-2011)
		JP2010522046A	01 July 2010 (01-07-2010)
		JP2011521718A	28 July 2011 (28-07-2011)
		US2009228008A1	10 September 2009 (10-09-2009)
		US8128627B2	06 March 2012 (06-03-2012)
		US2008287951A1	20 November 2008 (20-11-2008)
		US2009216232A1	27 August 2009 (27-08-2009)
		US2009228007A1	10 September 2009 (10-09-2009)
		WO2008116175A2	25 September 2008 (25-09-2008)
		WO2008116175A3	06 November 2008 (06-11-2008)
		WO2009143374A2	26 November 2009 (26-11-2009)
		WO2009143374A8	23 December 2010 (23-12-2010)
		WO2009143374A3	10 February 2011 (10-02-2011)