



US 20130199005A1

(19) **United States**
(12) **Patent Application Publication**
FUNG

(10) **Pub. No.: US 2013/0199005 A1**
(43) **Pub. Date: Aug. 8, 2013**

(54) **EYE FASTENER**

Publication Classification

(71) Applicant: **TEXCO HOOK & EYE TAPE LTD.**,
Kowloon (HK)

(51) **Int. Cl.**
A44B 13/00 (2006.01)

(72) Inventor: **Wing Leung FUNG**, Kowloon (HK)

(52) **U.S. Cl.**
CPC *A44B 13/0058* (2013.01)
USPC **24/698.2**

(73) Assignee: **TEXCO HOOK & EYE TAPE LTD.**,
Kowloon (HK)

(57) **ABSTRACT**

(21) Appl. No.: **13/749,125**

(22) Filed: **Jan. 24, 2013**

An eye fastener (100, 200) of the present disclosure includes two anchor portions (102, 202) defining a base plane, and an eye (106, 206) extending from the anchor portions (102, 202), each eye (106, 206) defining a plane of opening which is displaced relative to the base plane. A tape (116, 216) including an array of eye fasteners (100, 200) is also disclosed.

(30) **Foreign Application Priority Data**

Feb. 3, 2012 (EP) 12250019.2

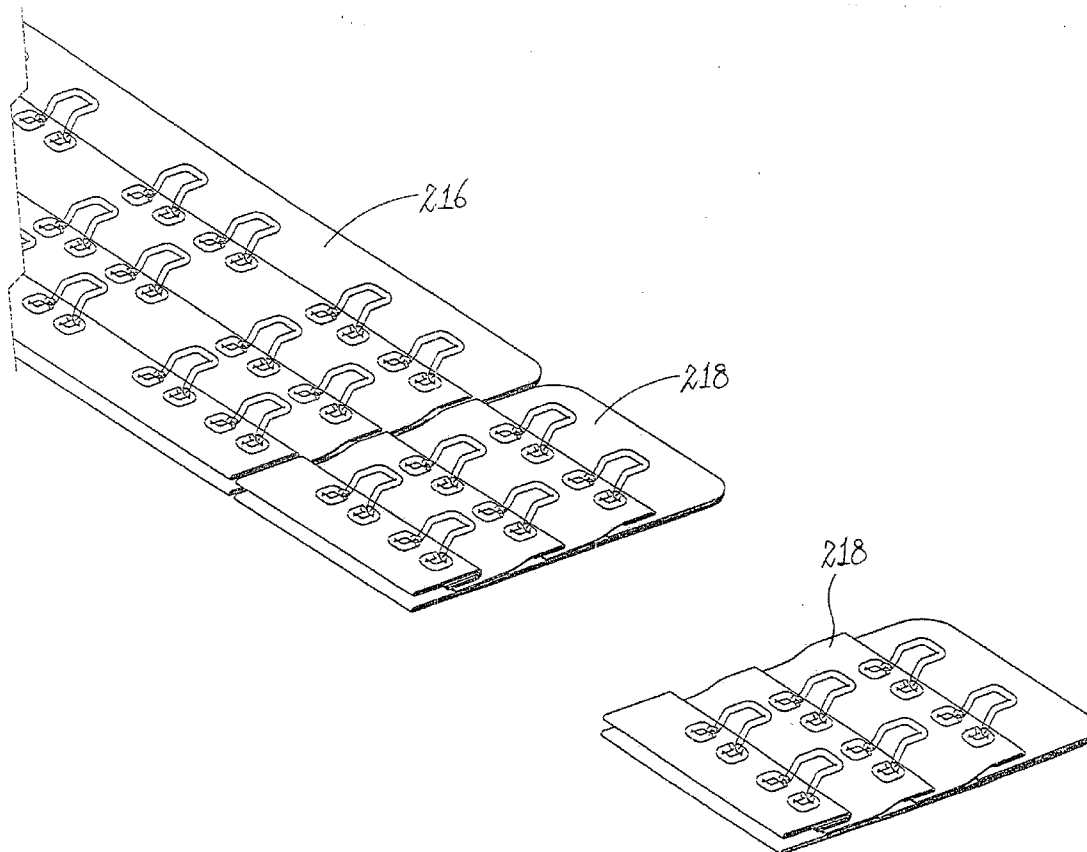

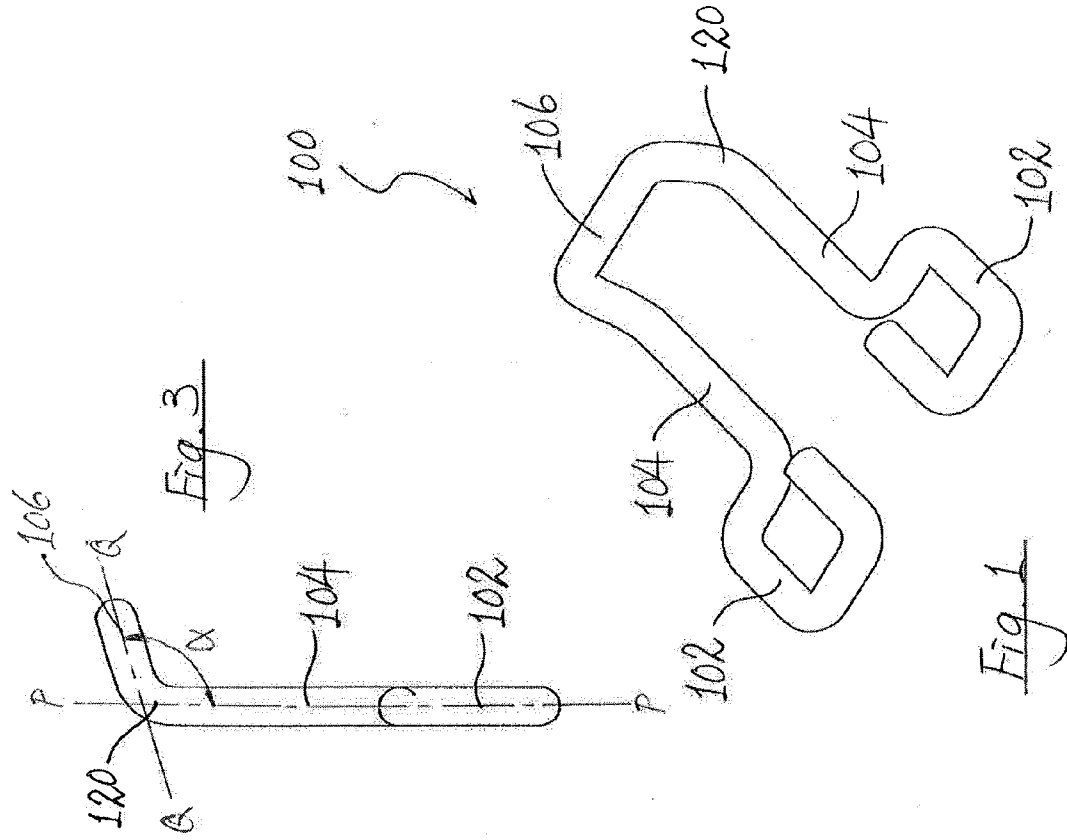

Fig. 1

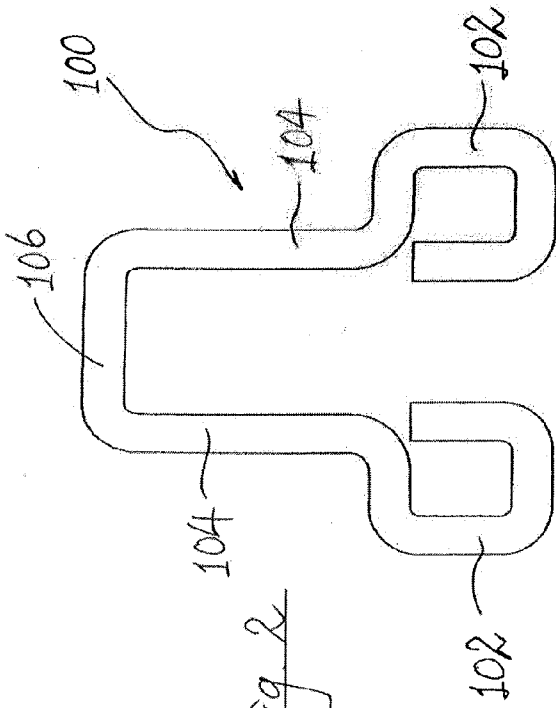

Fig. 2

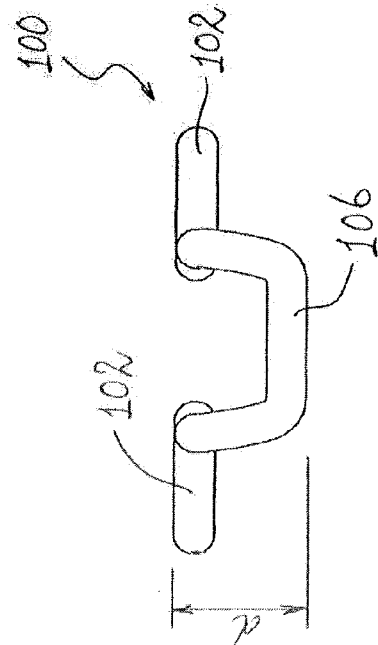

Fig. 3



Fig. 4

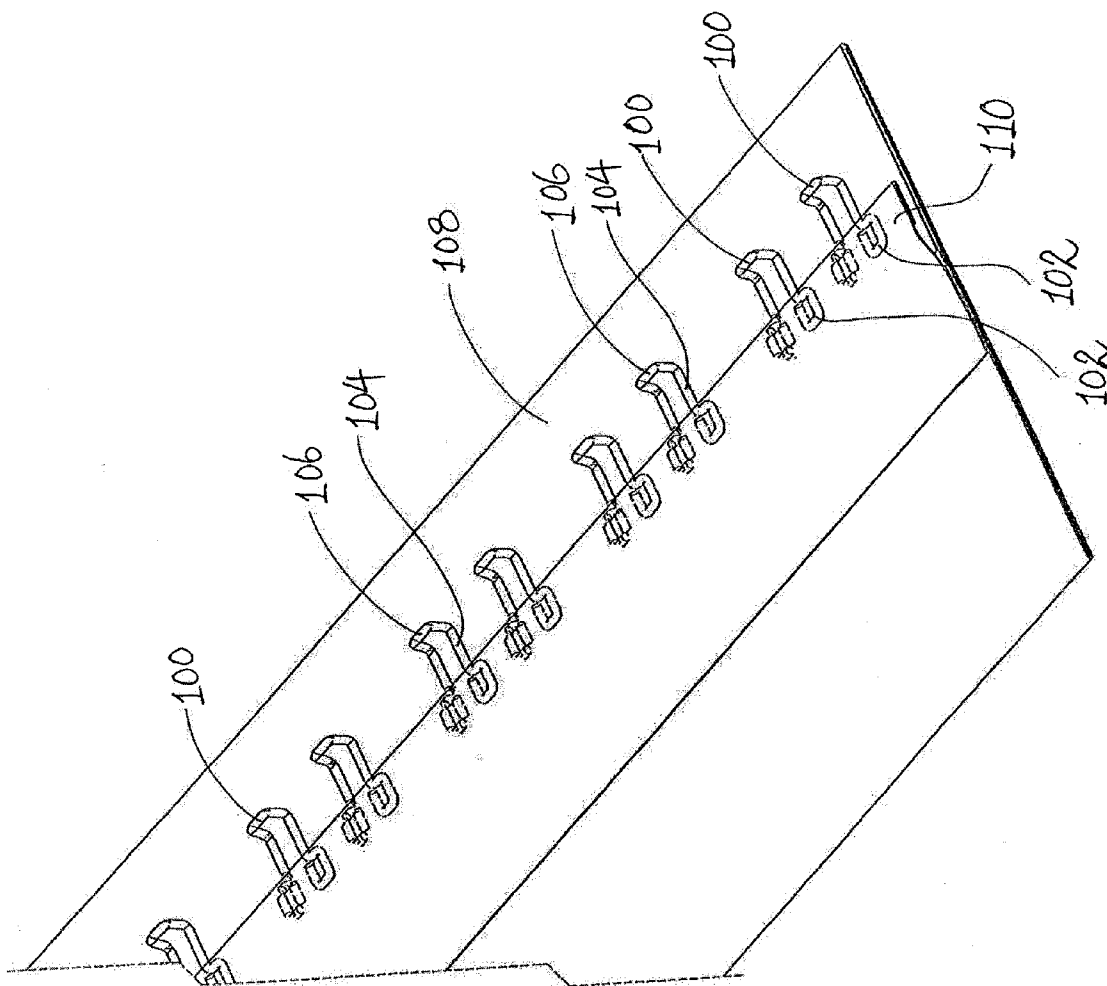

Fig. 5

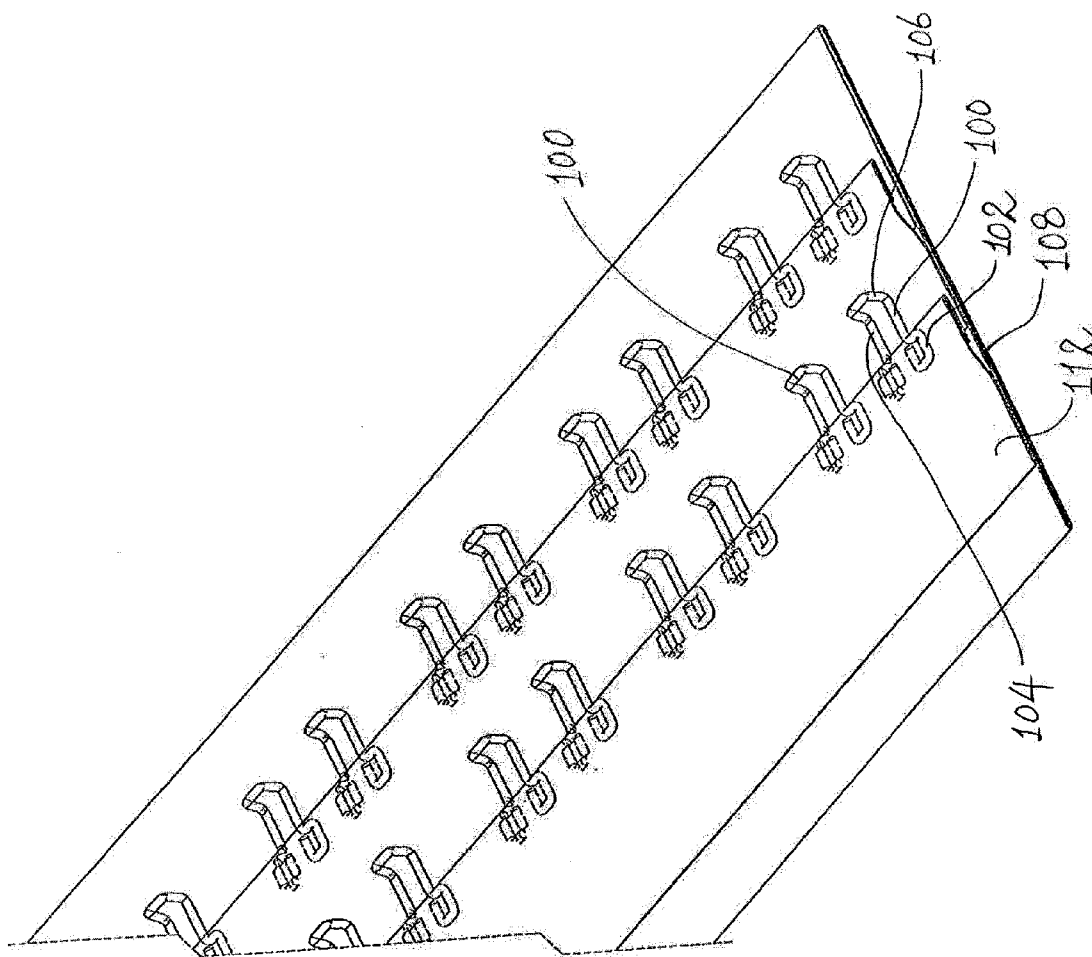

Fig. 6

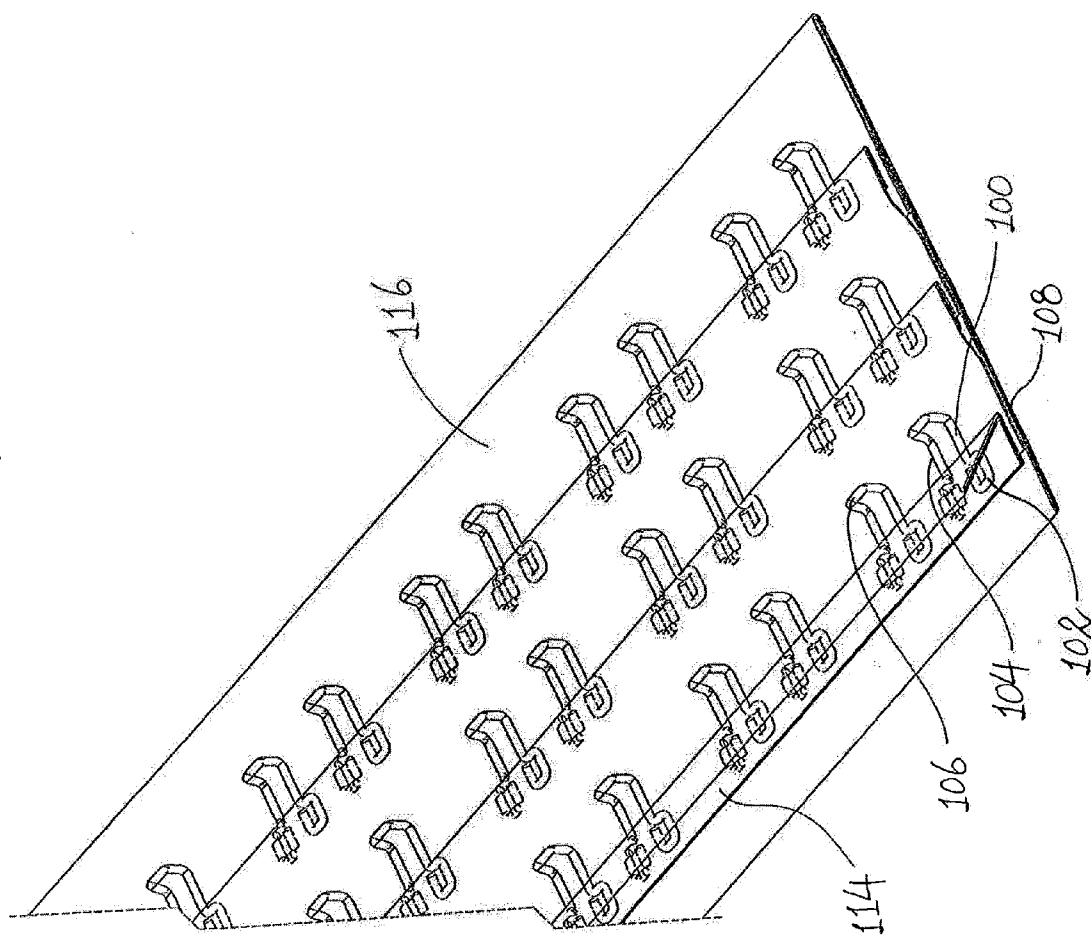

Fig. 7

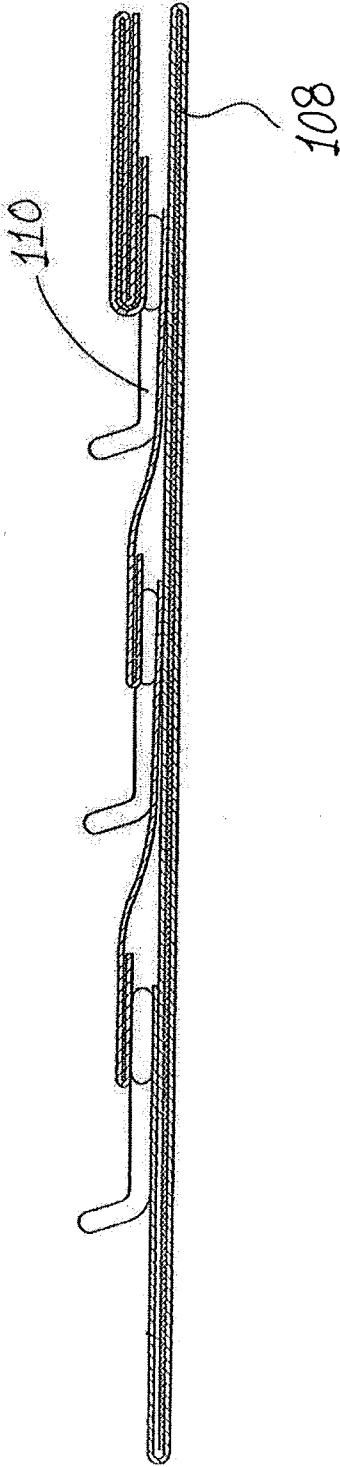

Fig. 8

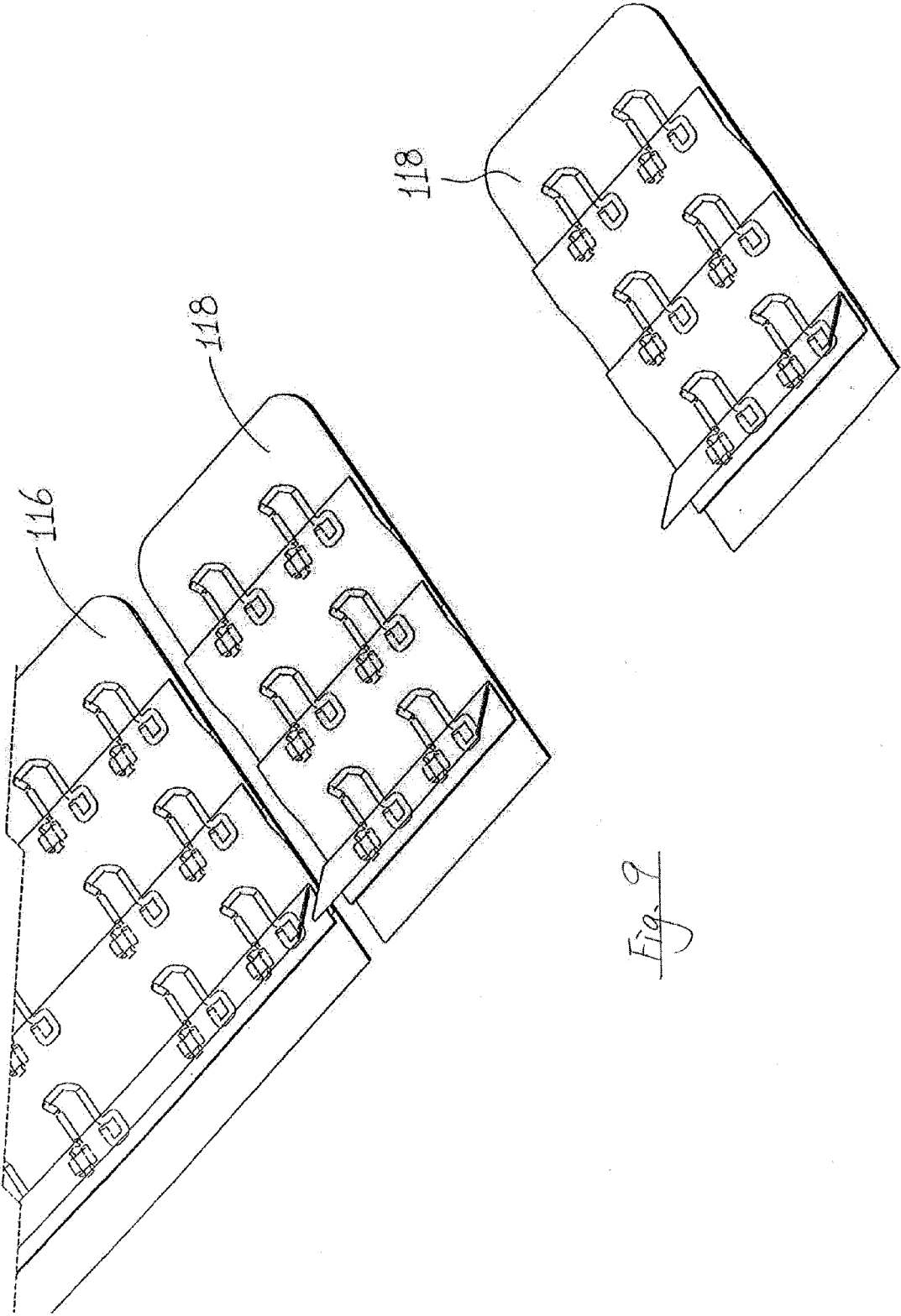
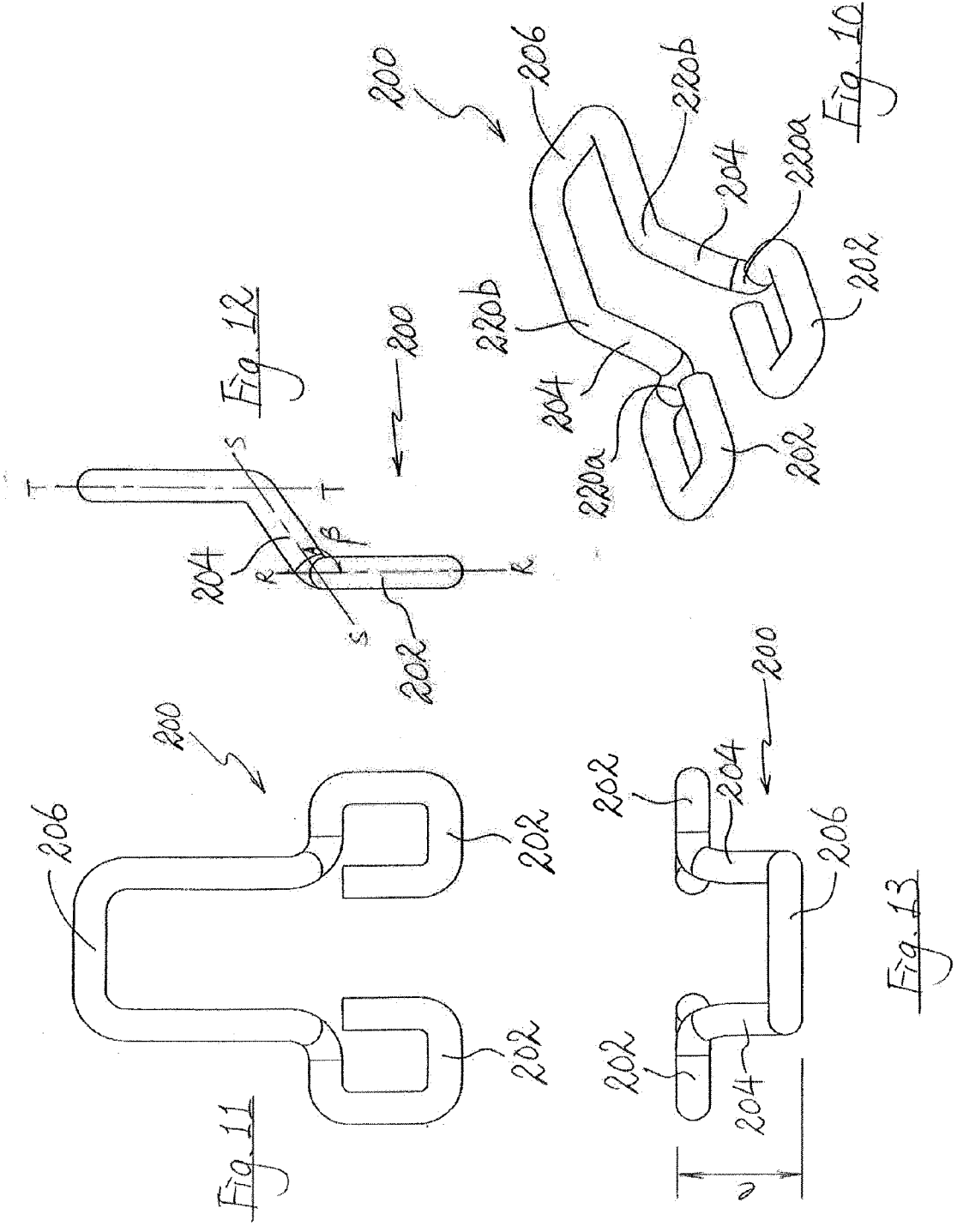

Fig. 9



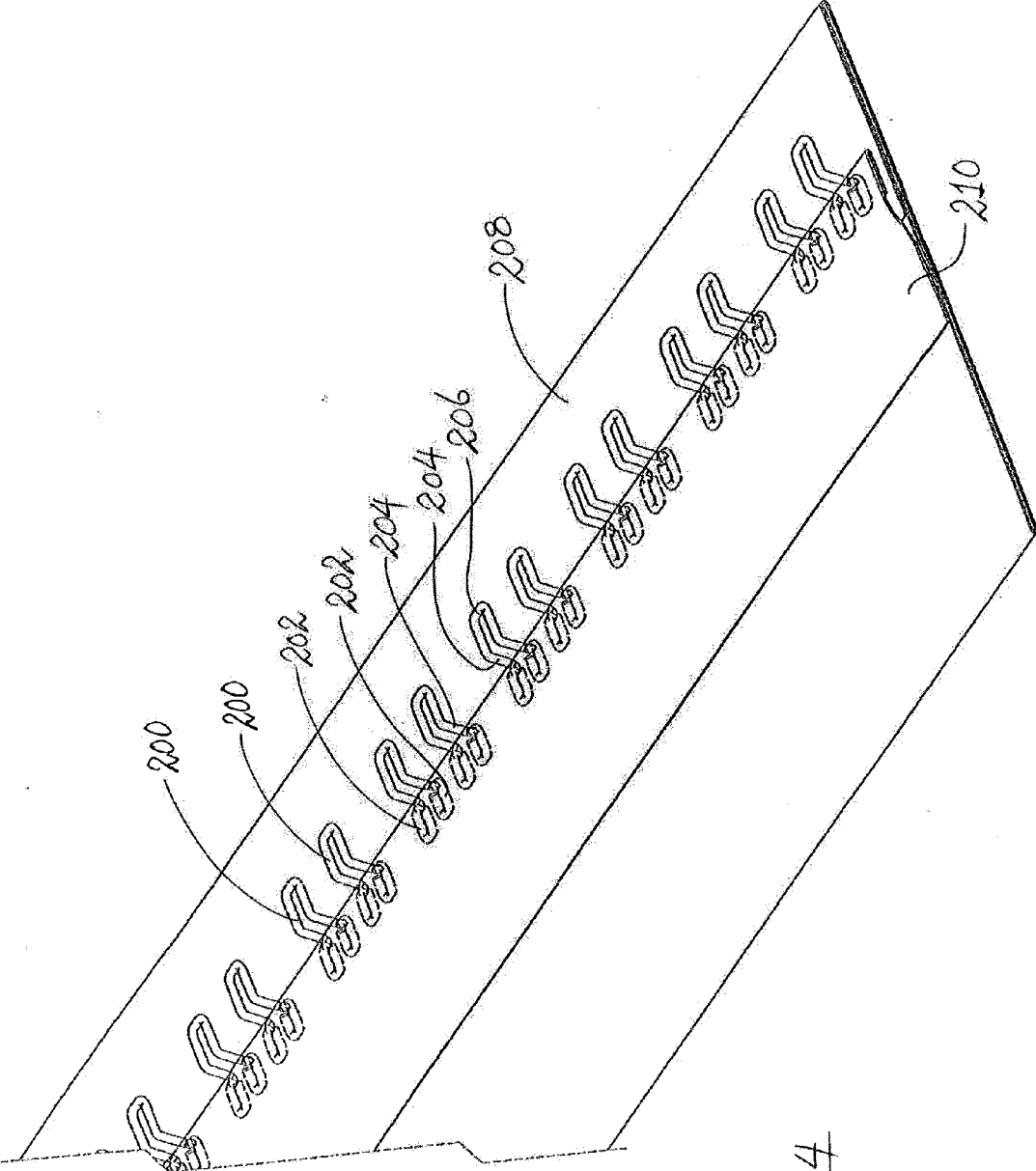

Fig. 14

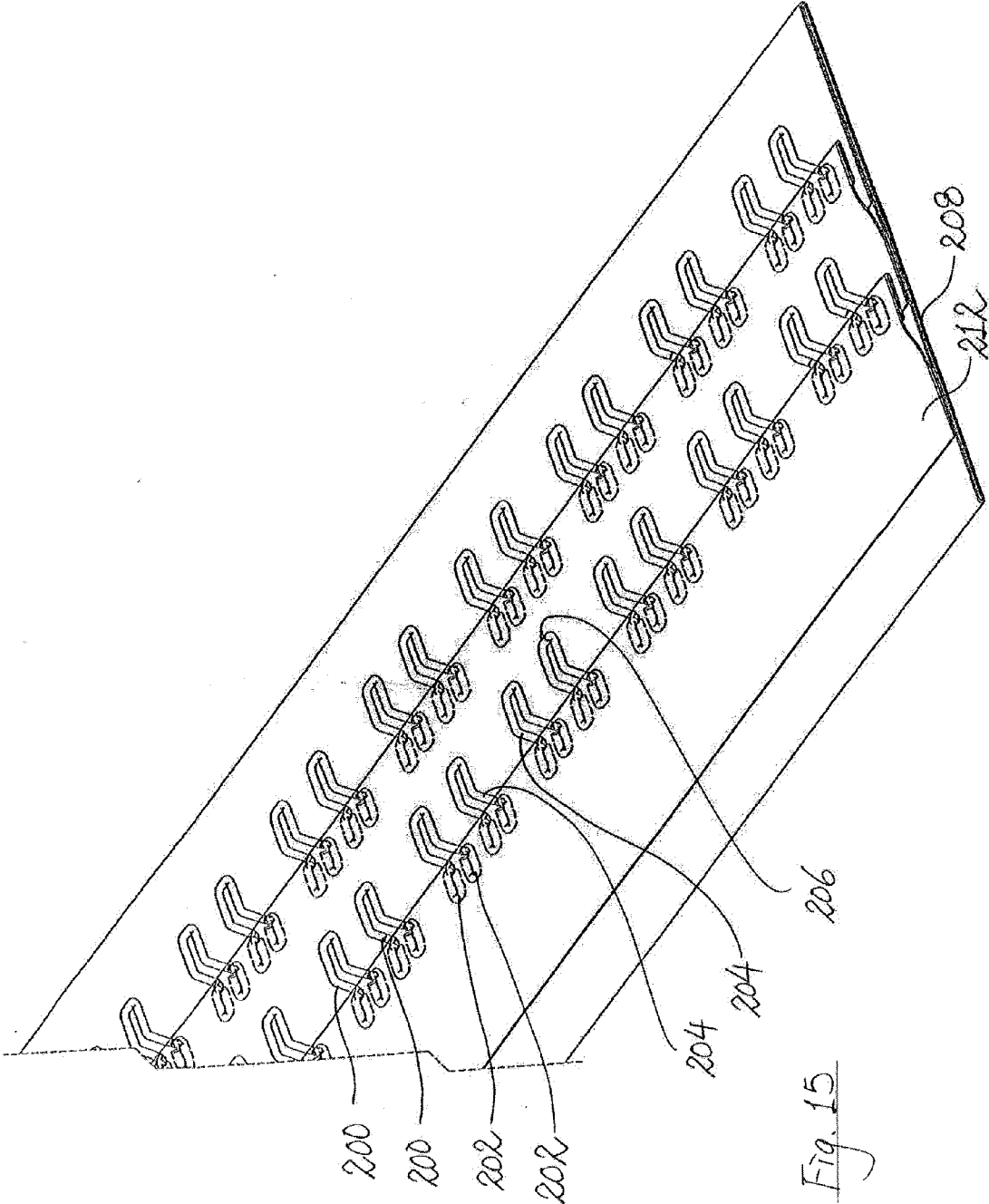
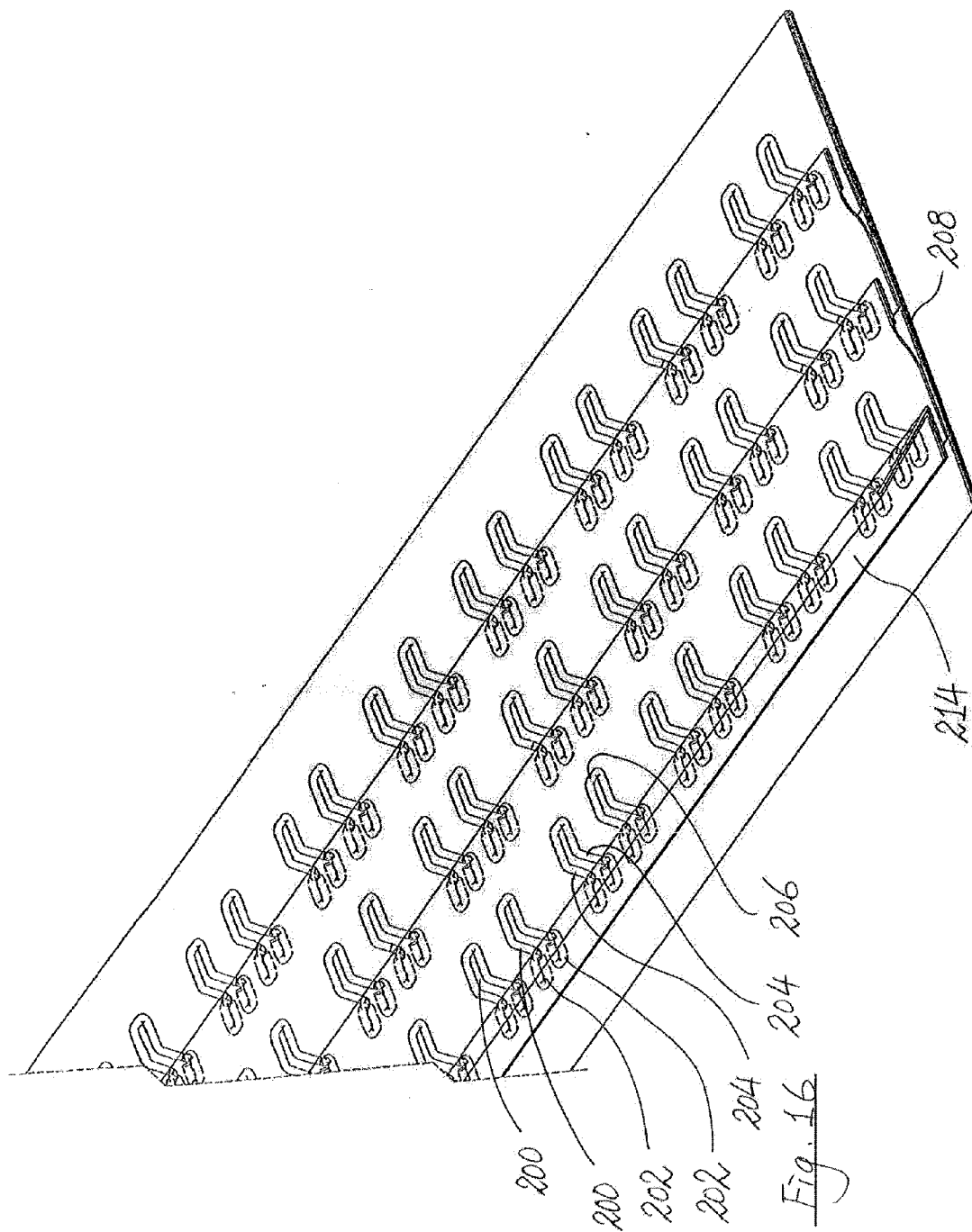

Fig. 15



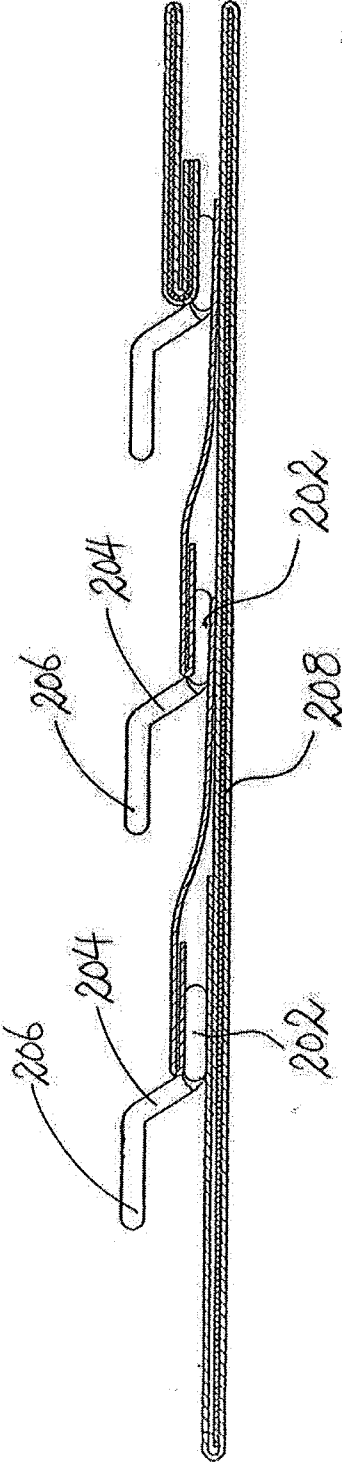

Fig. 17

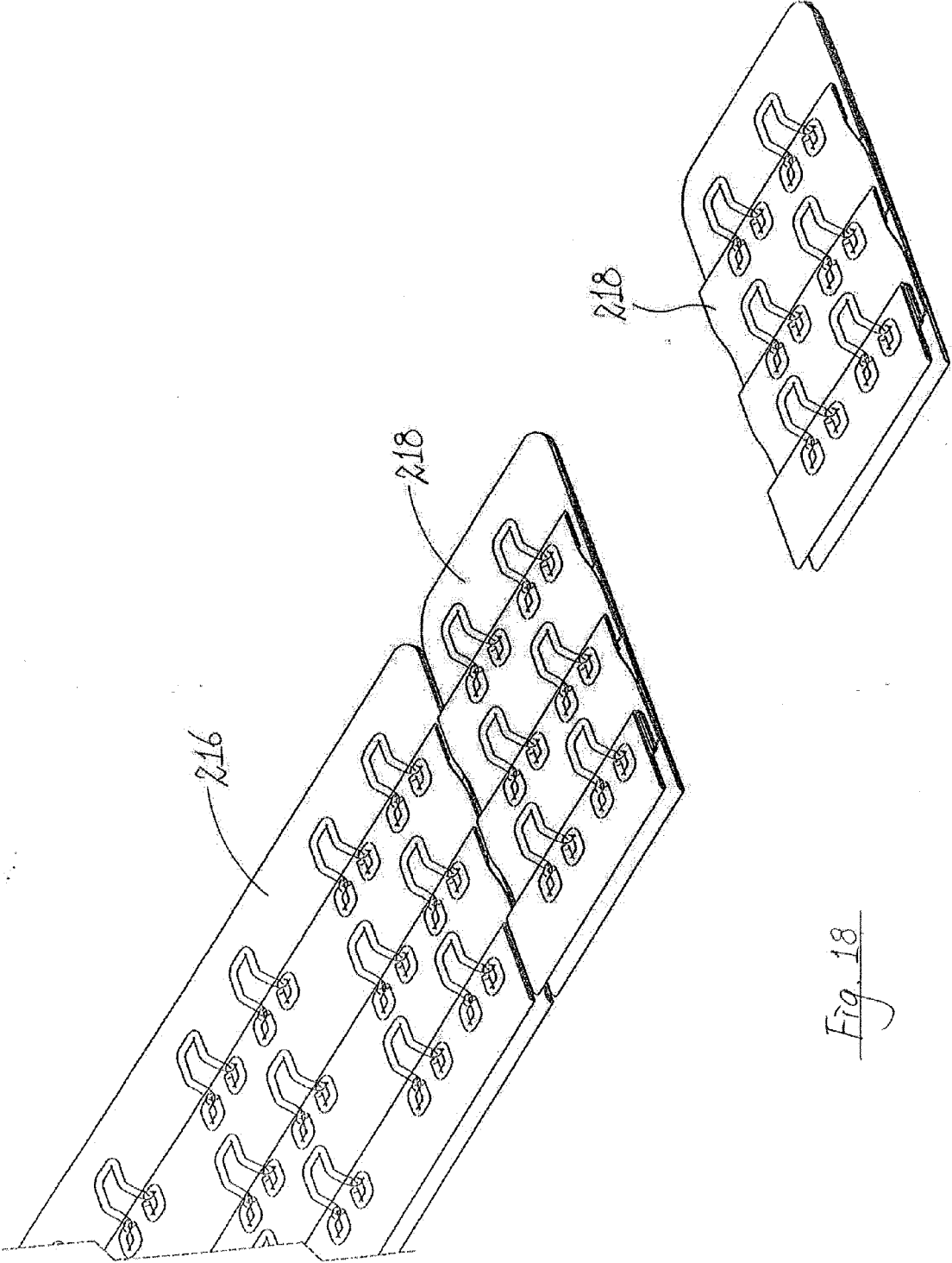
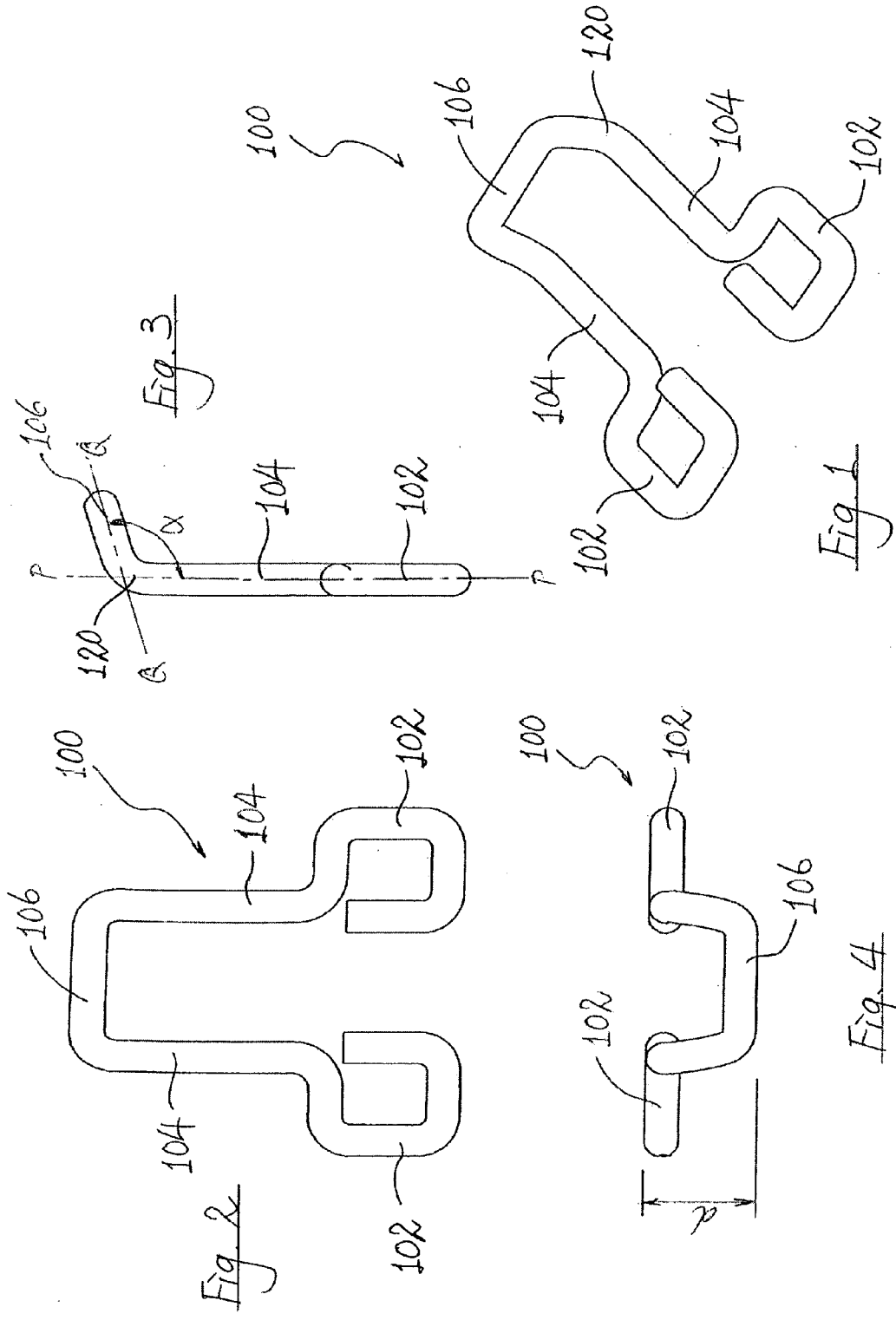

Fig. 18



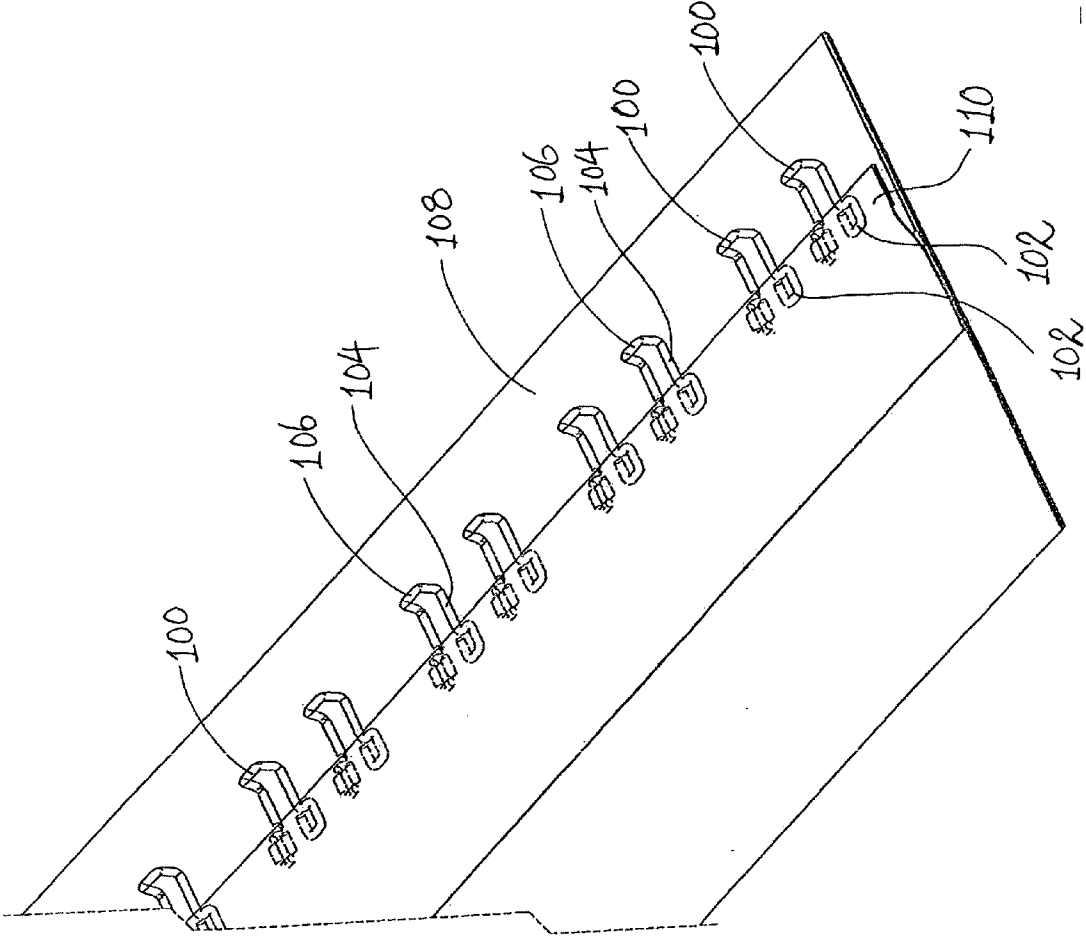

Fig. 5

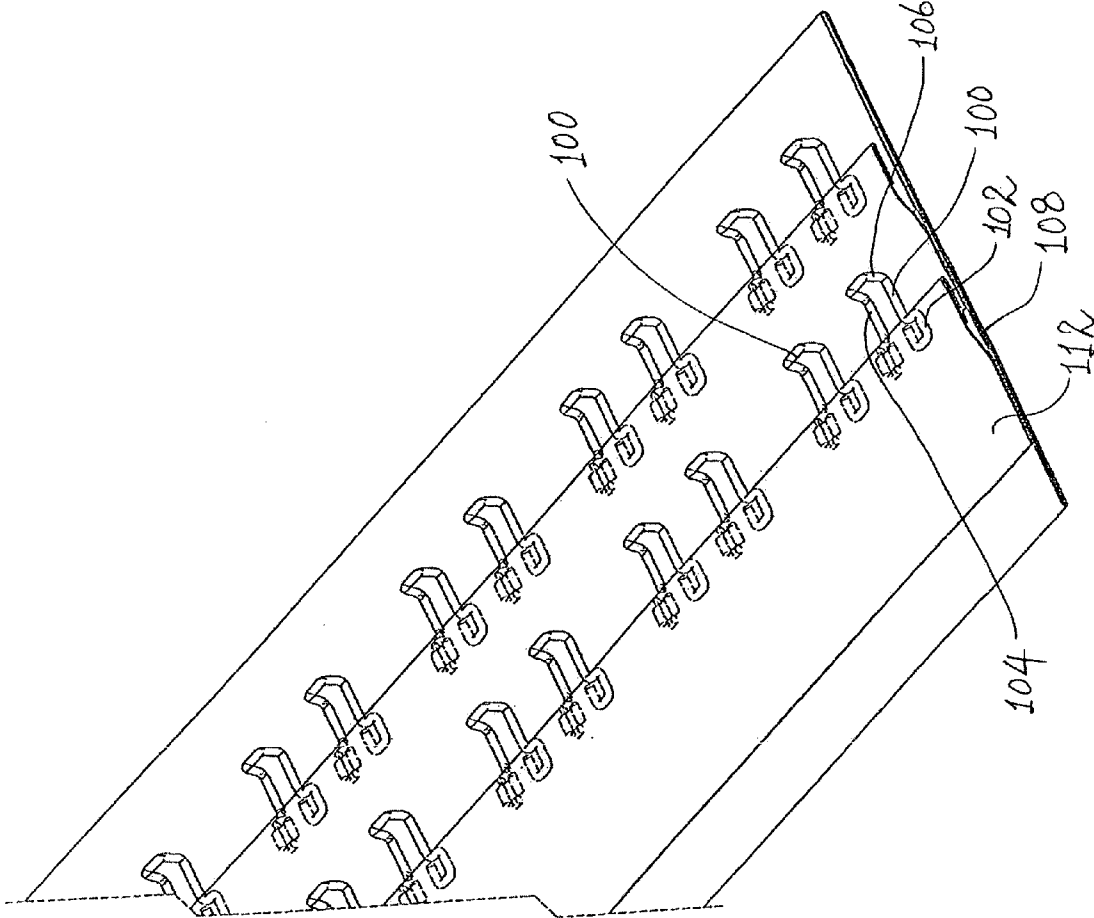

Fig. 6

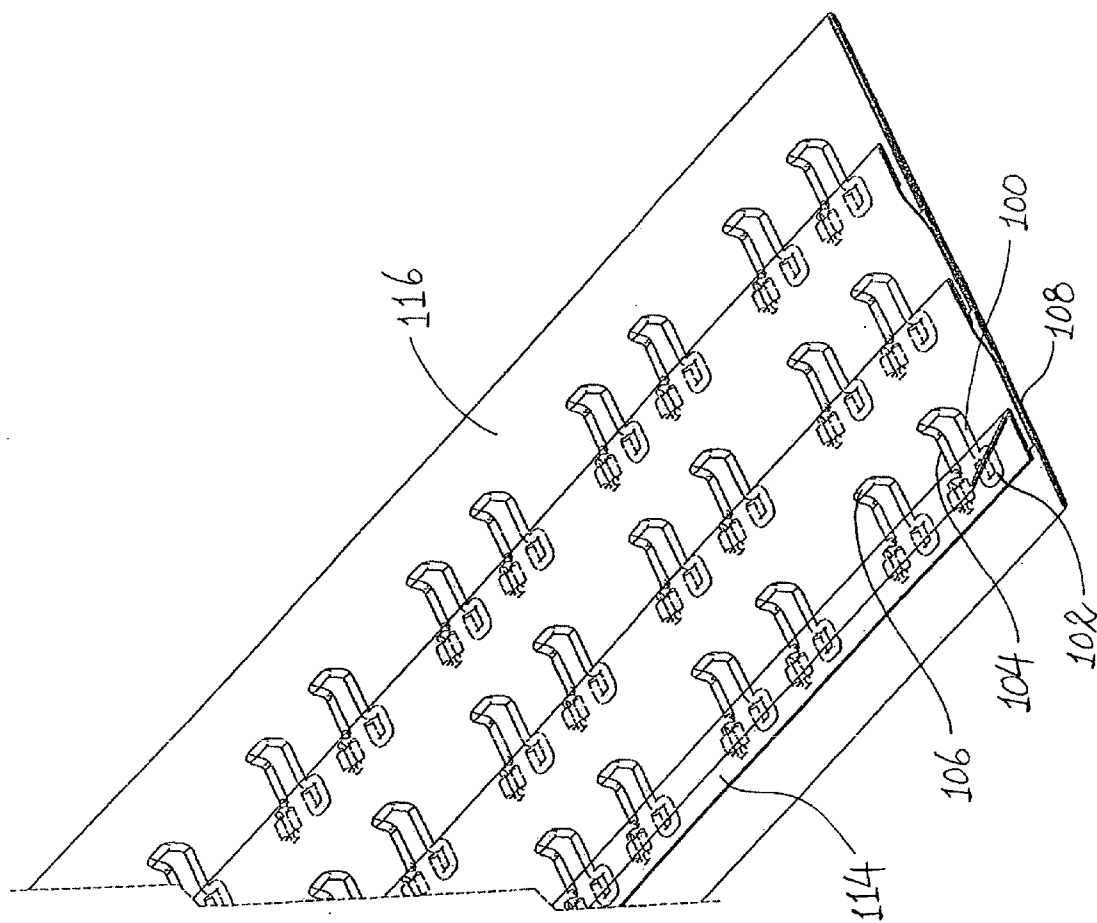

Fig. 7

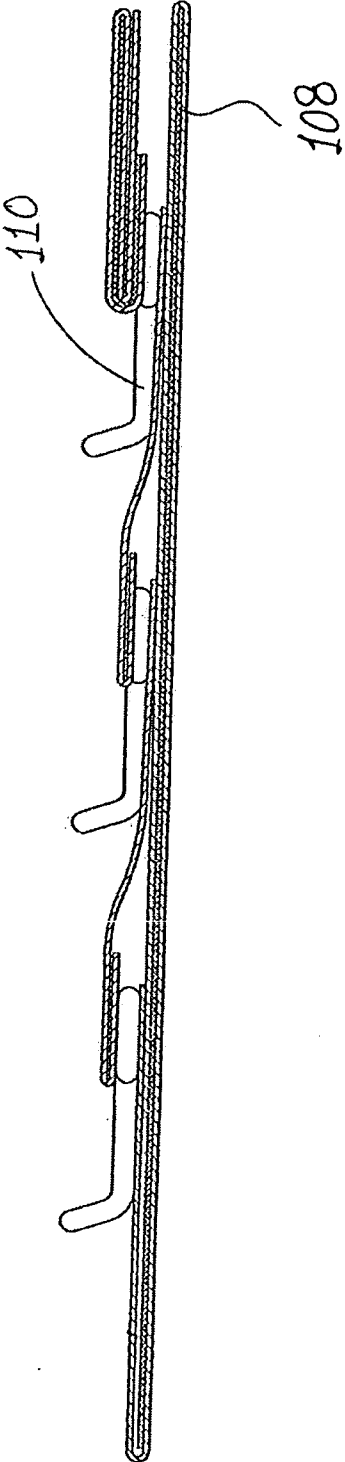

Fig. 8

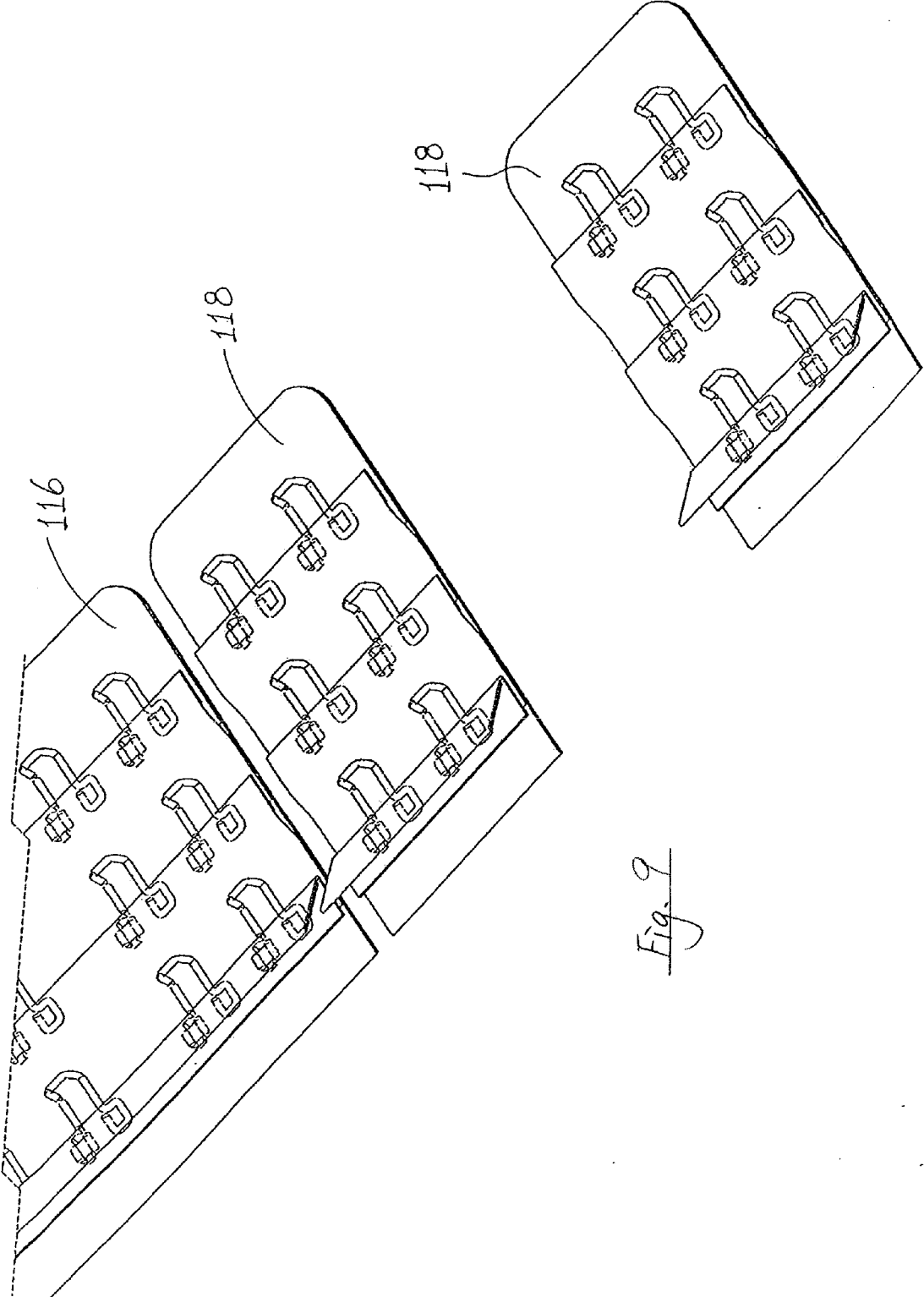
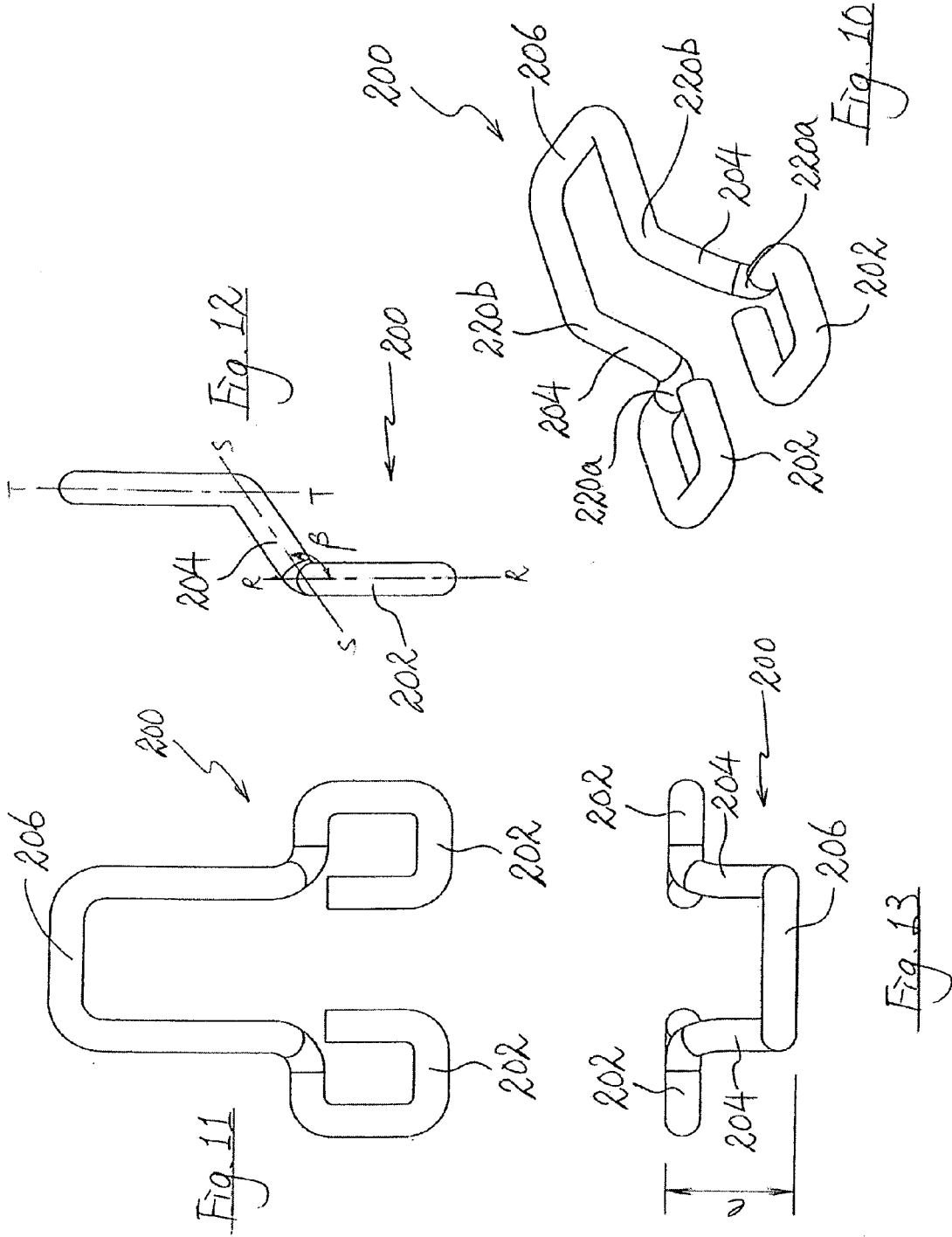

Fig. 9



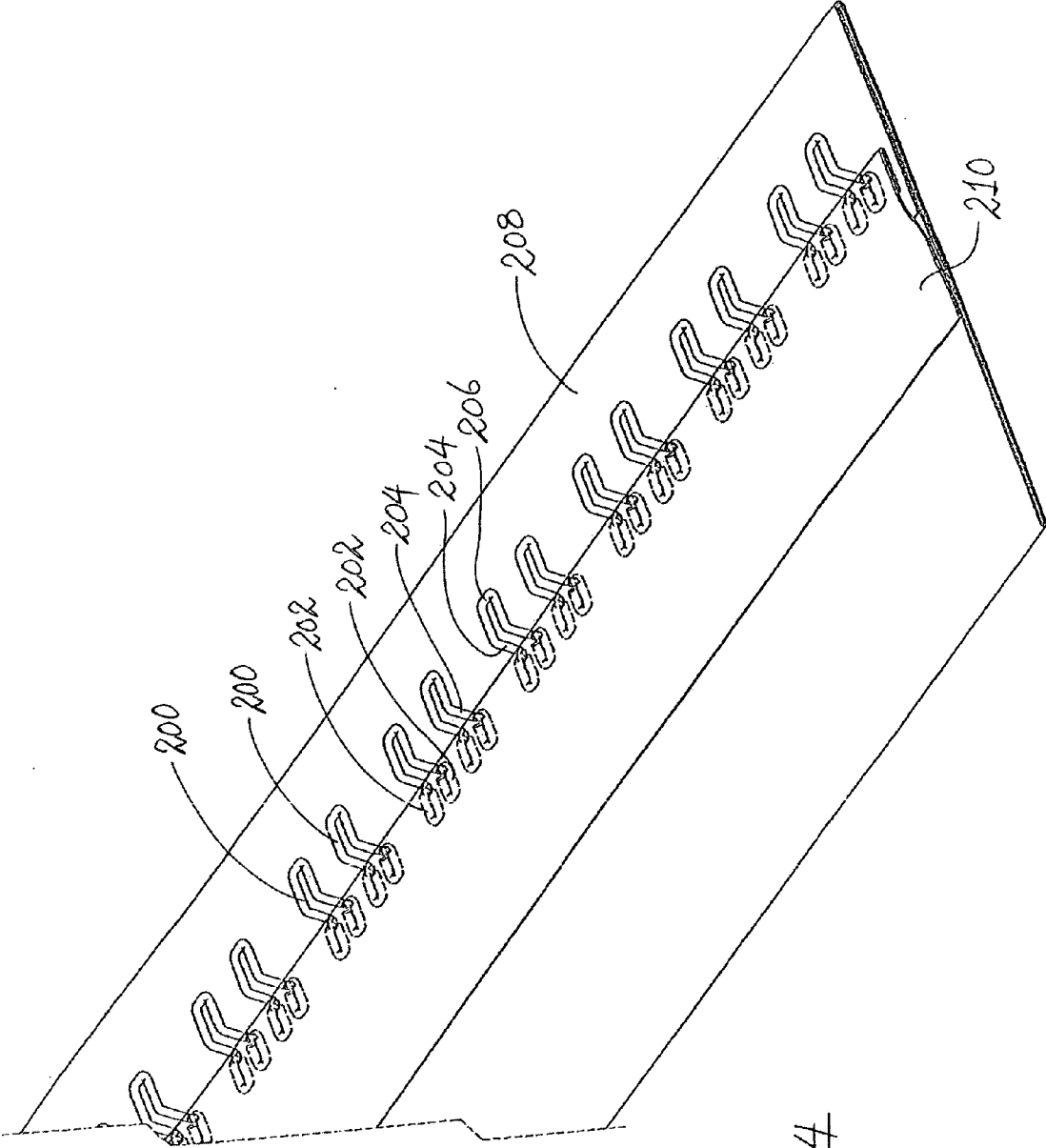

Fig 14

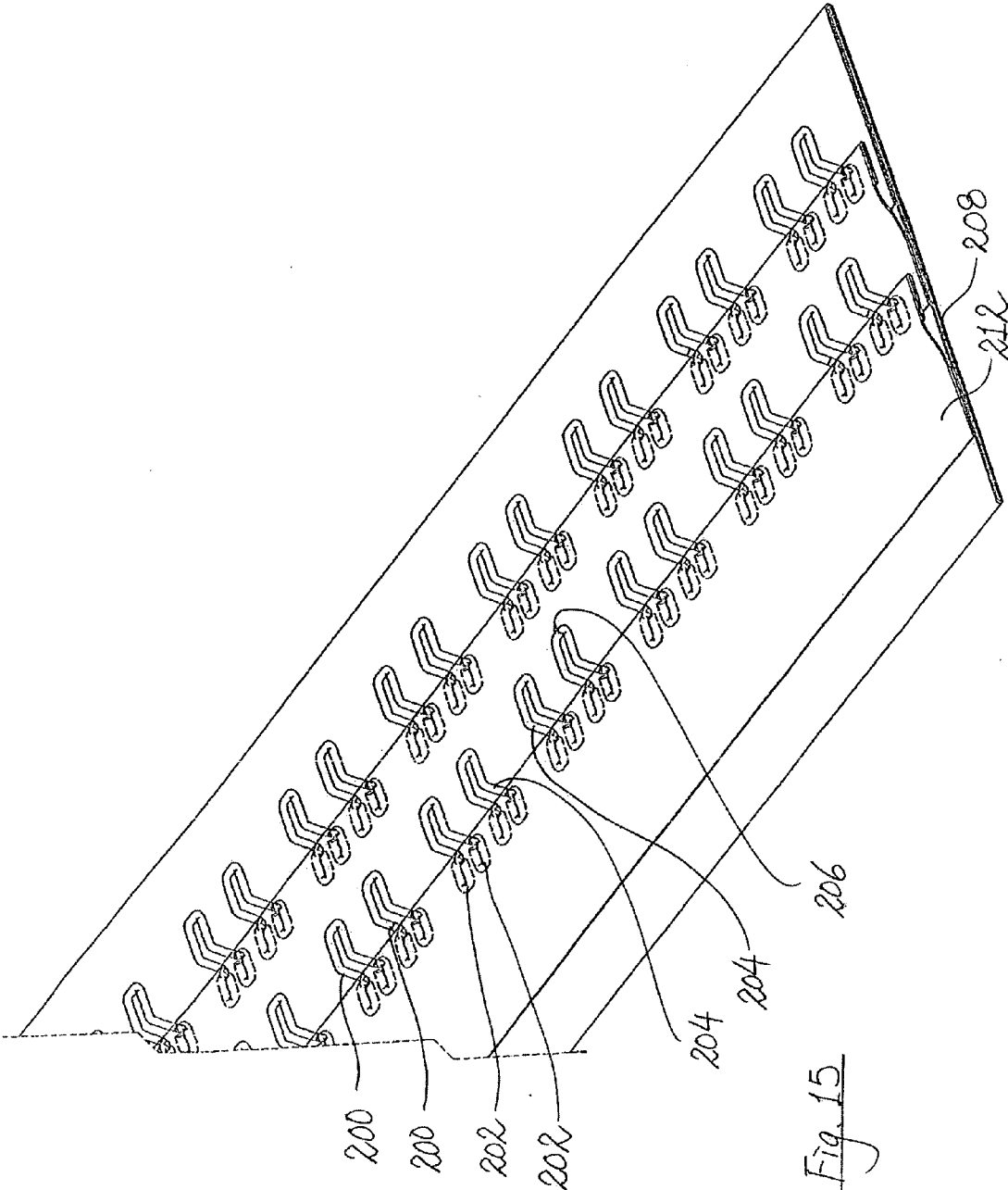
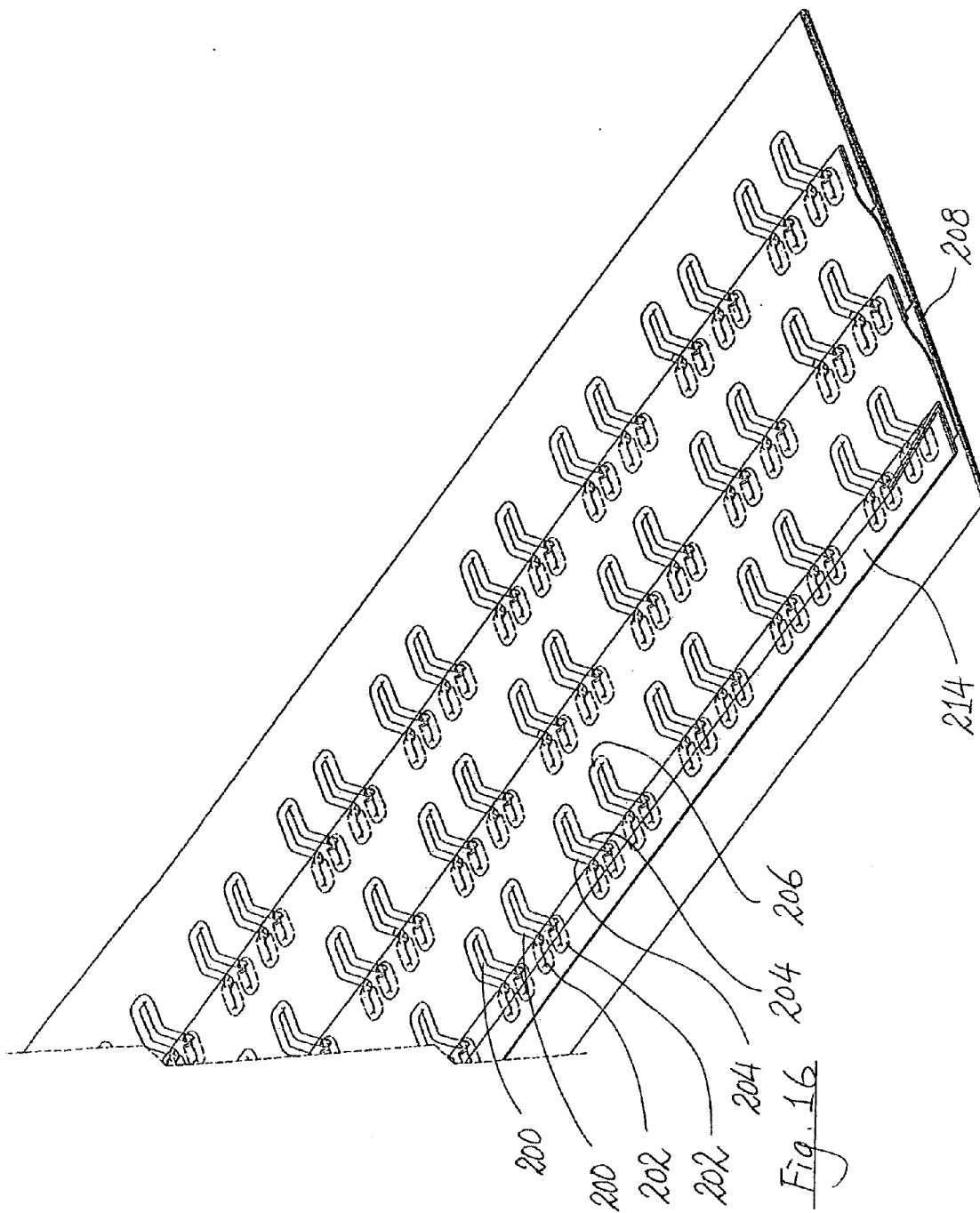

Fig. 15



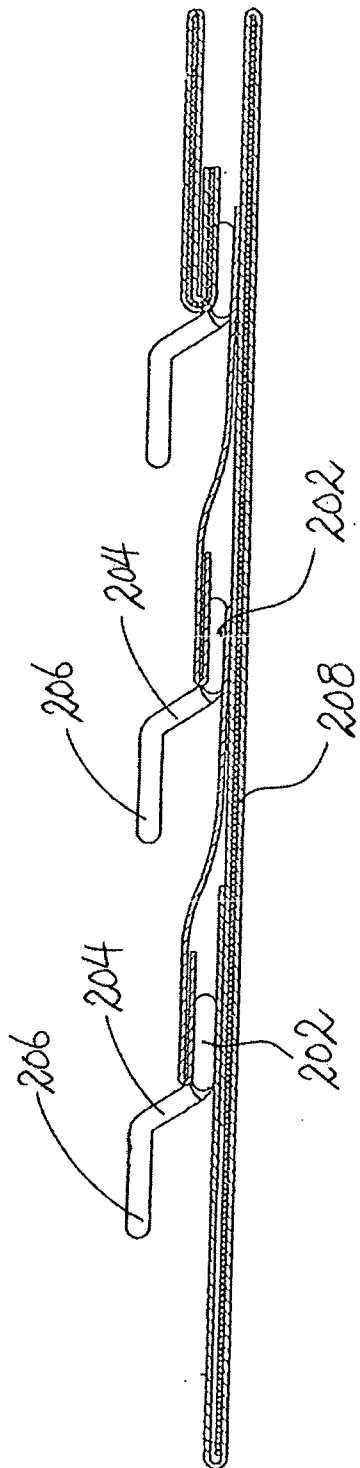

Fig. 17

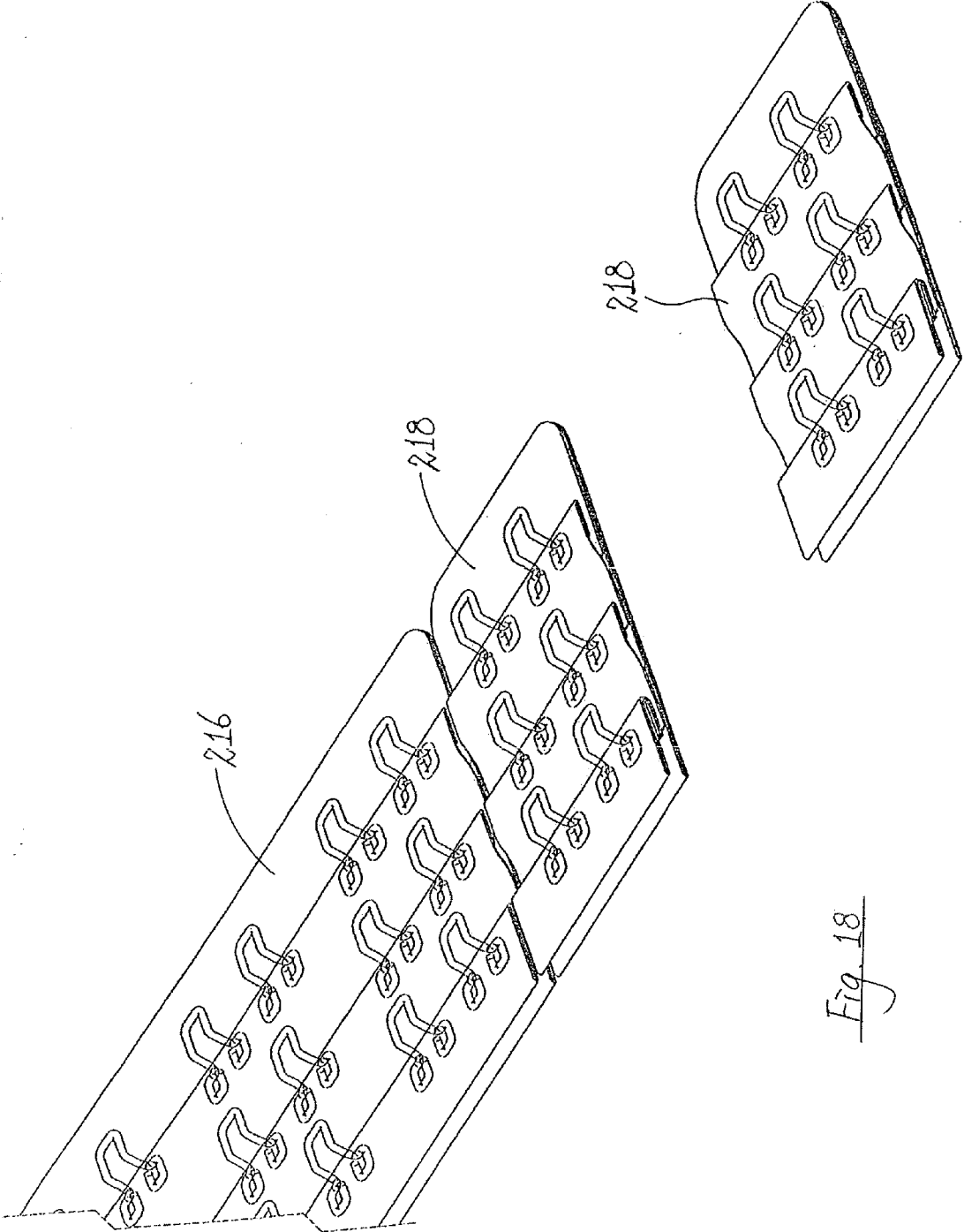

Fig. 18

EYE FASTENER

BACKGROUND OF THE INVENTION

[0001] 1. Technical Field

[0002] This invention relates to an eye fastener, in particular such a fastener suitable for forming an eye connector for use (but not exclusively) in garments items.

[0003] 2. Related Art

[0004] Many garment items, in particular lingerie (including brassieres), include connectors having hook and eye fasteners for providing flexible but firm coupling. In general, an array of hook fasteners (in rows and columns) is sewn onto a first tape, and a complementary array of eye fasteners is sewn into a second tape, and by engaging different hook fasteners and eye fasteners, a degree of lengthwise adjustment is allowed.

[0005] In such conventional hook and eye fasteners, both the eye fasteners and hook fasteners are typically formed of a stiff metal wire. The eye fasteners are generally C-shaped with two free ends sewn and received within the tape to form an opening, in which the plane defined by the opening of each eye fastener lies against the tape. It is found that when a user seeks to engage the eye fastener with a hook fastener, one has to slightly pivot the eye fastener away from the tape to further expose the plane of opening, to facilitate engagement with the hook fastener. This is relatively difficult, in particular in the case of brassieres, where the hook and eye fasteners are at the back of the user.

[0006] It is thus an object of the present invention to provide an eye fastener and a tape including at least one such eye fastener in which the above shortcoming is mitigated, or at least to provide a useful alternative to the trade and public.

SUMMARY OF THE INVENTION

[0007] According to a first aspect of the present invention, there is provided an eye fastener including a base defining a base plane, and at least an eye extending from the base and defining a plane of opening, characterized in that the plane of opening is displaced relative to the base plane.

[0008] According to a second aspect of the present invention, there is provided a tape including at least one eye fastener, the eye fastener including a base defining a base plane, and at least an eye extending from the base and defining a plane of opening, characterized in that the plane of opening is displaced relative to the base plane.

BRIEF DESCRIPTION OF THE DRAWINGS

[0009] Embodiments of eye fasteners and tapes including at least one fastener according to the present invention will now be described, by way of examples only, with reference to the present invention, in which:

[0010] FIG. 1 is a top perspective view of an eye fastener according to a first embodiment of the present invention;

[0011] FIG. 2 is a bottom view of the eye fastener shown in FIG. 1;

[0012] FIG. 3 is a side view of the eye fastener shown in FIG. 2;

[0013] FIG. 4 is an end view of the eye fastener shown in FIG. 2;

[0014] FIG. 5 shows a row of eye fasteners shown in FIG. 1 sewn to a tape;

[0015] FIG. 6 shows two rows of eye fasteners shown in FIG. 1 sewn to the tape in FIG. 5;

[0016] FIG. 7 shows three rows of eye fasteners shown in FIG. 1 sewn to the tape in FIG. 6;

[0017] FIG. 8 is an enlarged side sectional view of the tape shown in FIG. 7;

[0018] FIG. 9 shows eye connectors formed out of the tape shown in FIG. 7;

[0019] FIG. 10 is a top perspective view of an eye fastener according to a second embodiment of the present invention;

[0020] FIG. 11 is a bottom view of the eye fastener shown in FIG. 10;

[0021] FIG. 12 is a side view of the eye fastener shown in FIG. 11;

[0022] FIG. 13 is an end view of the eye fastener shown in FIG. 11;

[0023] FIG. 14 shows a row of eye fasteners shown in FIG. 10 sewn to a tape;

[0024] FIG. 15 shows two rows of eye fasteners shown in FIG. 10 sewn to the tape in FIG. 14;

[0025] FIG. 16 shows three rows of eye fasteners shown in FIG. 10 sewn to the tape in FIG. 15;

[0026] FIG. 17 is an enlarged side sectional view of the tape shown in FIG. 16; and

[0027] FIG. 18 shows eye connectors formed out of the tape shown in FIG. 16.

DESCRIPTION OF PREFERRED EMBODIMENTS

[0028] An eye fastener according to a first embodiment of the present invention is shown in FIGS. 1 to 4, and generally designated as 100. The eye fastener 100 is formed integrally of a wire (such as a metal wire), e.g. by bending. The eye fastener 100 has two anchor portions 102 (each being a free end of the eye fastener 100), two parallel leg portions 104 each extending from a respective of the anchor portions 102, and a generally C-shaped portion 106 joining, extending from and bent relative to the two leg portions 104.

[0029] The anchor portions 102 form a base, defining a base plane P-P, on which the leg portions 104 also lie. The C-shaped portion 106, which extends from the base, forms an opening ("eye") through which a hook fastener may be releasably engaged. It can be seen from FIG. 3 that the plane Q-Q defined by the C-shaped portion 106 ("plane of opening") is displaced relative to the plane P-P defined by the anchor portions 102 and leg portions 104 ("base plane"), and the two planes P-P, Q-Q are joined via bent portions 120. Although the angle α between the plane of opening Q-Q and the base plane P-P is shown in FIG. 3 as being an obtuse angle, such may alternatively be a right angle or an acute angle. The distance d between the uppermost end of the C-shaped portion 106 and the leg portions 104 (and the anchor portions 102) is from 0.5 mm to 5 mm.

[0030] As shown in FIG. 5, to produce a tape with an array of eye fasteners 100, a first row of eye fasteners 100 are assembled between a backing sheet 108 and a first layer of padding material 110. In particular, the first row of eye fasteners 100 are arranged along a straight line, with their anchor portions 102 fixed (e.g. by sewing) between the backing sheet 108 and the first layer of padding material 110, and with their leg portions 104 and C-shaped portions 106 exposed to the outside environment.

[0031] As shown in FIG. 6, a second row of eye fasteners 100 are assembled between the backing sheet 108 and a second layer of padding material 112. In particular, the second row of eye fasteners 100 are arranged along a straight line

which is parallel to the straight line along which the first row of eyes **100** are arranged. Again, the anchor portions **102** of the second row of eye fasteners **100** are fixed between the backing sheet **108** and the second layer of padding material **112**. The leg portions **104** and C-shaped portions **106** of the second row of eye fasteners **100** are also exposed to the outside environment.

[0032] Finally, as shown in FIG. 7, a third row of eye fasteners **100** are assembled between the backing sheet **108** and a third layer of padding material **114**. In particular, the third row of eye fasteners **100** are arranged along a straight line which is parallel to the straight lines along which the first and second rows of eye fasteners **100** are arranged. Again, the anchor portions **102** of the third row of eye fasteners **100** are fixed between the backing sheet **108** and the third layer of padding material **114**. The leg portions **104** and C-shaped portions **106** of the third row of eye fasteners **100** are also exposed to the outside environment.

[0033] A tape **116** with three rows of eye fasteners **100** fixed thereto is thus formed. There is of course no definite restriction on the number of rows of eye fasteners **100** which may be carried by the tape **116**. A manufacturer may decide on the number of rows of eye fasteners **100** for the tape **116** according to the use to which eye connectors formed from the tape **116** are to be put.

[0034] As shown in FIG. 8, the plane of the backing sheet **108** is parallel to the base plane P-P of the eye fasteners **100**, and is displaced relative to the plane of opening Q-Q of the eye fasteners **100**.

[0035] Turning to FIG. 9, it can be seen that eye connectors **118** each with an array of two-by-three eye fasteners **100** are formed from the tape **116**. Such eye connectors **118** may be formed by cutting the continuous tape **116** transversely by a cutter vibrated ultrasonically at intervals. The eye connectors **118** so formed may then be sewn onto semi-finished brassieres for forming final products.

[0036] An eye fastener according to a second embodiment of the present invention is shown in FIGS. 10 to 13, and generally designated as **200**. The eye fastener **200** is formed integrally of a wire (such as a metal wire), e.g. by bending. In particular, the eye fastener **200** has two anchor portions **202** (each being a free end of the eye fastener **200**), two parallel leg portions **204** extending from and bent relative to the anchor portions **202**, and a generally C-shaped portion **206** joining, extending from and bent relative to the two leg portions **204**.

[0037] The anchor portions **202** form a base, defining a base plane R-R. The leg portions **204** and the C-shaped portion collectively form an opening ("eye") through which a hook fastener may be releasably engaged. The leg portions **204** define a first plane S-S and the C-shaped portion **206** defines a second plane T-T. The first plane S-S and the second plane T-T collectively form a plane of opening. It can be seen from FIG. 12 that the plane S-S defined by the leg portions **204** (i.e. the first plane) is displaced relative to the base plane R-R, and the plane T-T defined by the C-shaped portion **206** (i.e. the second plane) is displaced relative to the first plane S-S and is parallel to the base plane R-R. The base plane R-R and the first plane S-S are joined with each other via first bent portions **220a**; and the first plane S-S and the second plane T-T are joined with each other via second bent portions **220b**. Although the angle β between the first plane S-S and the base plane R-R is shown in FIG. 12 as being an obtuse angle, such may alternatively be a right angle or an acute angle. The

distance e between the uppermost end of the C-shaped portion **206** and the anchor portions **202** is from 0.5 mm to 5 mm.

[0038] As shown in FIG. 14, to produce a tape with an array of eye fasteners **200**, a first row of eye fasteners **200** are assembled between a backing sheet **208** and a first layer of padding material **210**. In particular, the first row of eye fasteners **200** are arranged along a straight line, with their anchor portions **202** fixed (e.g. by sewing) between the backing sheet **208** and the first layer of padding material **210**, and with their leg portions **204** and C-shaped portions **206** exposed to the outside environment.

[0039] As shown in FIG. 15, a second row of eye fasteners **200** are assembled between the backing sheet **208** and a second layer of padding material **212**. In particular, the second row of eye fasteners **200** are arranged along a straight line which is parallel to the straight line along which the first row of eyes **200** are arranged. Again, the anchor portions **202** of the second row of eye fasteners **200** are fixed between the backing sheet **208** and the second layer of padding material **212**. The leg portions **204** and C-shaped portions **206** of the second row of eye fasteners **200** are also exposed to the outside environment.

[0040] Finally, as shown in FIG. 16, a third row of eye fasteners **200** are assembled between the backing sheet **208** and a third layer of padding material **214**. In particular, the third row of eye fasteners **200** are arranged along a straight line which is parallel to the straight lines along which the first and second rows of eye fasteners **200** are arranged. Again, the anchor portions **202** of the third row of eye fasteners **200** are fixed between the backing sheet **208** and the third layer of padding material **214**. The leg portions **204** and C-shaped portions **206** of the third row of eye fasteners **200** are also exposed to the outside environment.

[0041] A tape **216** with three rows of eye fasteners **200** fixed thereto is thus formed. It should of course be understood that a manufacturer may decide on the number of rows of eye fasteners **200** for the tape **216** according to the use to which eye connectors formed from the tape **216** are to be put.

[0042] As shown in FIG. 17, the plane of the backing sheet **208** is:

[0043] parallel to the base plane R-R of each eye fastener **200**,

[0044] displaced relative to the first plane S-S of the plane of opening as defined by the leg portions **204** of each eye fastener **200**, and

[0045] parallel to the second plane T-T of the plane of opening as defined by the C-shaped portion **206** of each eye fastener **200**.

[0046] Turning to FIG. 18, it can be seen that eye connectors **218** each with an array of two-by-three eye fasteners **200** are formed from the tape **216**. Such eye connectors **218** may be formed by cutting the continuous tape **216** transversely by a cutter vibrated ultrasonically at intervals. The eye connectors **218** so formed may then be sewn onto semi-finished brassieres for forming final products.

[0047] It can be seen from the foregoing discussion and the accompanying drawings that as the plane of opening of the respective eye fasteners **100**, **200** according to this invention is displaced relative to the respective base plane P-P, R-R (which lie against the respective backing sheet **108**, **208**), such allows easy engagement between eye connectors **118**, **218** and complementary hook connectors.

[0048] It should be understood that the above only illustrates examples whereby the present invention may be carried

out, and that various modifications and/or alterations may be made thereto without departing from the spirit of the invention.

[0049] It should also be understood that certain features of the invention, which are, for clarity, described in the context of separate embodiments, may be provided in combination in a single embodiment. Conversely, various features of the invention which are, for brevity, described in the context of a single embodiment, may also be provided separately or in any appropriate sub-combinations.

What is claimed is:

1. An eye fastener comprising:
a base defining a base plane, and
at least an eye extending from the base and defining a plane of opening,
wherein the plane of opening is displaced relative to the base plane.
2. The eye fastener as claimed in claim 1, wherein the plane of opening is connected to the base plane via a bent.

3. The eye fastener as claimed in claim 1, wherein the plane of opening includes a first plane and a second plane displaced relative to the first plane.

4. The eye fastener as claimed in claim 1, wherein the plane of opening is substantially perpendicular to the base plane.

5. The eye fastener as claimed in claim 3, wherein the first plane is substantially perpendicular to the base plane.

6. The eye fastener as claimed in claim 3, wherein the second plane is substantially parallel to the base plane.

7. A tape including at least one eye fastener as claimed in claim 1.

8. The tape as claimed in claim 7, further comprising a backing sheet and at least one layer of padding material on the backing sheet.

9. The tape as claimed in claim 8, wherein the base of the eye fastener is between the backing sheet and the layer of padding material.

10. The tape as claimed in claim 7, wherein the base plane of the eye fastener is substantially parallel to the backing sheet.

* * * * *