

June 7, 1949.

G. R. HOWE

2,472,076

SCRAPER GUIDE

Filed May 20, 1947

Fig. 1.

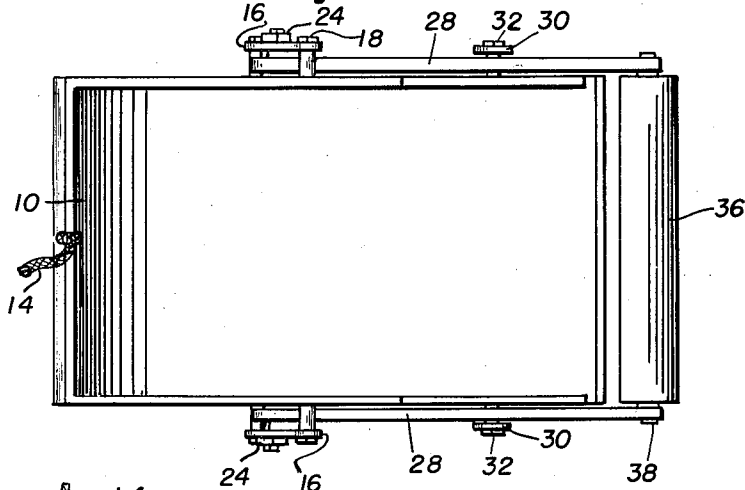

Fig. 2.

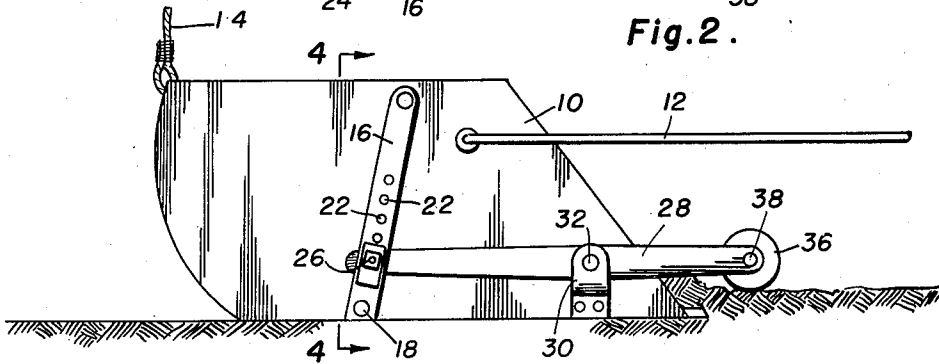

Fig. 3.

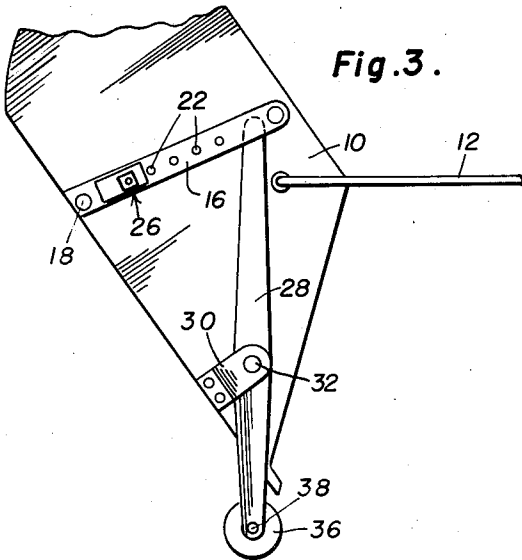
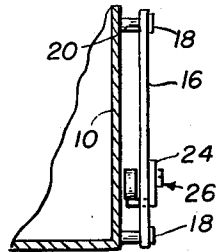

Fig. 4.



Inventor

George R. Howe

By

Clarence A. O'Brien
and Harvey B. Jacobson
Attorneys

UNITED STATES PATENT OFFICE

2,472,076

SCRAPER GUIDE

George R. Howe, Medaryville, Ind.

Application May 20, 1947, Serial No. 749,247

2 Claims. (Cl. 37-135)

1

This invention apertains to novel and useful improvements in scrapers or drag line shovels.

An object of this invention is to provide means for controlling the depth of cut taken by a conventional drag line bucket or the like.

Another object of this invention is to provide means for selectively controlling the travel of said above mentioned means.

Another object of the present invention is to provide improved, simplified seating means for said last mentioned means.

A further purpose of the present invention is to provide an extremely simple, inexpensive and satisfactorily operative device of the character described utilized in obtaining precision cutting in the usual operation of drag line buckets and the suitable equivalents.

Other objects and features of novelty shall become apparent to those skilled in the art, in following the description of the preferred embodiment of the present invention, illustrated in the accompanying drawings, wherein:

Figure 1 is a plan view of the preferred embodiment of the present invention;

Figure 2 is an elevational side view of the invention disclosed in Figure 1;

Figure 3 is an elevational view of the invention disclosed in Figure 2, showing the same in a selected position of operation in the suspended position, and

Figure 4 is a sectional detail of construction taken substantially on the line 4-4 of Figure 2 and in the direction of the arrows.

Referring now in detail to the illustrated preferred embodiment of the present invention, like reference characters are used throughout to indicate similar elements.

This invention has been conceived and developed to provide a device affording a depth control for utility with conventional drag line buckets, scoops, shovels and the like which are employed in excavating and leveling operations. It is often desirable to level certain portions of land prior to constructing roads, parks and other ostentatious edifices. Conventional leveling devices such as baffles positioned in front of or behind tractors serve the purpose of leveling, however, this mechanism does not remove the refuse and undesired products in a single operation. Accordingly, it is one of the other and secondary purposes of the present invention to also remove refuse and undesired products along with the leveling operation. Ordinary drag line buckets are utilized in retaining coal, land and the like, the resulting surface not being taken into consideration. Accordingly,

2

this invention intends to convert or further expand the utility of conventional drag line buckets in order that they may be used in relatively precision leveling operations.

For illustrative purposes, a conventional shovel or bucket 10 is disclosed having the usual tow lines 12 and dump line 14 secured thereto. A pair of brackets 16 of any suitable material, preferably metallic, are secured in spaced relation relative to the sides of the said bucket 10. Any suitable conventional securing means may be utilized such as rivets or bolts 18 having sleeves 20 interposed between the said brackets 16 and the bucket 10. A plurality of apertures 22 are provided along the longitudinal axis of the said bracket 16 and the perch 24 is received in selected apertures. This perch is preferably a right angular bracket as disclosed in Figure 4 having a bolt and nut construction 26 extending there-

through. A pair of arms 28 are pivotally secured to the forward end of the said bucket 10. The preferable pivot means comprises a pair of bearing brackets 30 riveted or otherwise secured adjacent the lower edge of the said bucket 10, having an aperture provided therein. Then, any suitable pivot pin 32 may extend through said aperture and through the arms 28, thus anchoring arm 28 to the side of the bucket 10.

Depth control means is provided at selected terminal portions of the said arms 28 and is preferably a simple roller 36 rotatively journaled on a shaft 38. This shaft extends through the terminal portions of the said arms 28 and may be fixedly secured thereto by any suitable conventional means.

The opposite ends of the said arms 28 are adapted to seat on the limiting means or brackets 24.

As the shovel or bucket is rendered operative, the roller 36 rides on the upper surface of the turf or ground and due to the bite taken, the rear portions of the said arms 28 are forced against the seating portion of the bracket means 24. If a larger or smaller bite is desired, the seating means 24 is simply positioned in another selected aperture 22. This, obviously, regulates the difference between the bottom portion of the bucket 10 and the roller 36.

In dumping, as when the bucket or shovel 10 is full, proper manipulation of the line 12 and 14 is effected and due to the weight of the roller 36, the same will assume a position so as to be unobstructive in the said dumping operation. This position is clearly viewed in Figure 3.

3

As mentioned above, it is one of the purposes of the present invention to provide a mechanically simple device. Consequently, due to the extreme simplicity of the invention a further description thereof is deemed unnecessary. However, it is apparent that various changes as to size and shape, as well as adaptability of the present invention may be employed without departing from the spirit thereof. Accordingly, limitation is sought only in accordance with the scope of the following claims.

Having described the invention, what is claimed as new is:

1. A scraper guide comprising a drag line bucket having sides, a back, a bottom and an open front, brackets, means securing one of said brackets on each side in spaced relation relative to said sides, said brackets having apertures therein, arms, means pivotally securing said arms intermediate their ends to said sides for swinging movement in a travel above and below said bottom, means carried by one pair of ends of said arms for controlling the depth of cut taken by said bucket, means disposed in selected aper-

4

tures associated with the opposite ends of said arms for limiting pivotal travel of said arms, said depth control means including a ground engaging member rotatively secured to said arms across the open end of said bucket.

2. The combination of claim 1 and the said opposite ends of said arms engaging said bracket securing means to limit the pivotal movement of said arms in one direction and engaging the means disposed in said apertures for limiting the movement of said arms in the opposite direction.

GEORGE R. HOWE.

REFERENCES CITED

The following references are of record in the file of this patent:

UNITED STATES PATENTS

Number	Name	Date
493,421	Butler -----	Mar. 14, 1893
881,330	Newman -----	Mar. 10, 1908
1,017,293	Johnson -----	Feb. 13, 1912
1,167,146	Bunnell -----	Jan. 4, 1916