



- (51) International Patent Classification:
B41M 5/00 (2006.01)
- (21) International Application Number:
PCT/US2013/031801
- (22) International Filing Date:
14 March 2013 (14.03.2013)
- (25) Filing Language: English
- (26) Publication Language: English
- (72) Inventor; and
- (71) Applicant : STONES, Bryon [US/US]; 6122 W. Josephine Road, Queen Creek, AZ 85142-8942 (US).
- (74) Agent: JENKINS, Keith, L.; 44075 W Neely Drive, Maricopa, AZ 85138 (US).
- (81) Designated States (*unless otherwise indicated, for every kind of national protection available*): AE, AG, AL, AM, AO, AT, AU, AZ, BA, BB, BG, BH, BN, BR, BW, BY, BZ, CA, CH, CL, CN, CO, CR, CU, CZ, DE, DK, DM, DO, DZ, EC, EE, EG, ES, FI, GB, GD, GE, GH, GM, GT, HN, HR, HU, ID, IL, IN, IS, JP, KE, KG, KM, KN, KP,

KR, KZ, LA, LC, LK, LR, LS, LT, LU, LY, MA, MD, ME, MG, MK, MN, MW, MX, MY, MZ, NA, NG, NI, NO, NZ, OM, PA, PE, PG, PH, PL, PT, QA, RO, RS, RU, RW, SC, SD, SE, SG, SK, SL, SM, ST, SV, SY, TH, TJ, TM, TN, TR, TT, TZ, UA, UG, US, UZ, VC, VN, ZA, ZM, ZW.

- (84) Designated States (*unless otherwise indicated, for every kind of regional protection available*): ARIPO (BW, GH, GM, KE, LR, LS, MW, MZ, NA, RW, SD, SL, SZ, TZ, UG, ZM, ZW), Eurasian (AM, AZ, BY, KG, KZ, RU, TJ, TM), European (AL, AT, BE, BG, CH, CY, CZ, DE, DK, EE, ES, FI, FR, GB, GR, HR, HU, IE, IS, IT, LT, LU, LV, MC, MK, MT, NL, NO, PL, PT, RO, RS, SE, SI, SK, SM, TR), OAPI (BF, BJ, CF, CG, CI, CM, GA, GN, GQ, GW, ML, MR, NE, SN, TD, TG).

Declarations under Rule 4.17:

- of inventorship (Rule 4.17(iv))

Published:

- with international search report (Art. 21(3))

(54) Title: APPARATUS FOR IMPROVED RECOVERY OF LATENT FINGERPRINTS

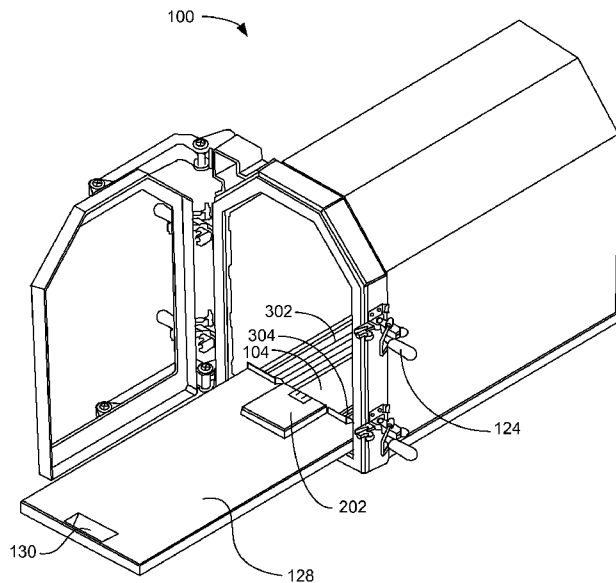

(57) Abstract: Hydrating a surface of a specimen bearing a latent fingerprint and then, by the present invention, restrictively vacuum drying the specimen leaving the fingerprint hydrated. The hydrated fingerprint is then exposed to flash heated cyanoacrylate ester in the vacuum chamber of the present invention. After drying reaches the preferred state, the cyanoacrylate ester is flash heated and selectively adheres to the condensation-hydrated latent fingerprint. The apparatus uses a controller for automatic vacuum drying and cyanoacrylate ester exposure of the latent fingerprint. The vacuum chamber is coupled to a cabinet which houses the vacuum pump, cyanoacrylate ester filter, controller, and power supply and externally supports a user interface. The operator simply puts the object in the chamber, pushes a button and the process completes automatically. Prints unrecoverable by prior art means are recovered. The door of the vacuum chamber uses a dual-hinge mechanism for improved sealing.

WO 2014/142934 A1

APPARATUS FOR IMPROVED RECOVERY OF LATENT FINGERPRINTS

FIELD OF THE INVENTION

[0001] This invention relates to an apparatus for improved recovery of latent fingerprints on nonporous surfaces for recovering fingerprints that cannot be recovered by prior art methods and apparatus. The invention further relates to an apparatus for improved recovery of latent fingerprints on nonporous surfaces for rehydrating latent fingerprints using an automatic control system with the apparatus.

BACKGROUND

[0002] Numerous methods of latent recovery have been developed and implemented resulting in cases being solved that would have been passed over in days past. The Cyanoacrylate Ester (CE) fuming process was developed in the late 1970's and is the most common method of processing currently in use for non-porous materials. Atmospheric CE is a method used to coat latent fingerprint residues with cyanoacrylate ester residue. The process involves an item being enclosed in a chamber, along with a heat source and a humidity source. The heat source is usually a coffee warmer and the humidity source warm water. The water can be introduced with a humidifier or just by placing a jar of warm water into the chamber. The liquid CE is placed into an aluminum weighing tray and heated changing the state from a liquid to a fume. The fume fills the chamber and deposits a white residue on waters and oils on the item. The resulting residue can be dusted with powders, dye stained, or photographed and is permanent until cleaned with acetone.

[0003] In the 1980's, CE fuming using vacuum in a chamber held some promise in the recovery of latent fingerprints on non-porous surfaces. The resulting prints were slight and needed to be

dye stained. Advancement to the vacuum CE fuming technique was introduced in 1989 with the addition of a heating element inside the vacuum chamber enhancing the polymerization of the cyanoacrylate ester (also known as “super glue”), changing the amount of residue on a latent fingerprint and shortening the time needed for processing. Vacuum CE with heat acceleration differs from Vacuum CE in that the CE is vaporized in a quicker fashion, similar to the atmosphere process using a hot plate. This allows for a denser concentration of CE particles to be dispersed within the chamber. Since vacuum CE is evenly dispersed in the chamber, increasing the density and number of CE particles results in a thicker deposition of CE on the ridges of the fingerprints and no deposit in the valleys. The fact that no deposition occurs in the valleys is common to all vacuum methods. Also common to all vacuum methods is the ability to reprocess an item multiple times. The exception for vacuum CE with heat acceleration when compared to vacuum CE without heat acceleration, is that the deposition of CE is much thicker when heated, resulting in having fewer processing repetitions for a quality latent print.

[0004] The drawback of both methods is that humidity is required for both. When humidity fills the chamber and deposits on the item, it deposits on both the ridge and the valley of a latent fingerprint. Most latent prints recovered are composed of sebaceous fluids and less of water content. When humidity is applied, moisture does deposit on the sebaceous ridge detail and enhance the latent print. Humidity, while enhancing a latent ridge detail, also coats the valley, preventing the latent from being processed any subsequent times. If it is processed a second time, the latent print coats white and all ridge detail is lost.

[0005] Older latent fingerprints have traditionally not even been processed when the age of the latent fingerprint that has been exposed to a hot environment (i.e. Arizona summer heat) was

discovered to be four days or more. It was deemed useless and a waste of time to go through latent processing when the result will be negative. Light latent fingerprints are subject to a similar decision making process. When a light latent fingerprint is discovered, additional processing using atmosphere CE is not possible. Therefore, the only option is to dye stain the CE ridge and hope enough dye is present to be visible using an Alternate Light Source, (ALS). An alternative to this problem is to process the item with vacuum CE with heat acceleration. Light latent fingerprints using this method of processing can be reprocessed many times to enhance CE ridge height. Often even vacuum CE with heat acceleration will not have a successful result on older latent fingerprints.

[0006] Therefore, a need exists for an apparatus and method for improved recovery of latent fingerprints on nonporous surfaces that can recover latent fingerprints that cannot be recovered by prior art means. A need also exists for an apparatus and method for improved recovery of latent fingerprints on nonporous surfaces that uses an automatic controller and can be automated to reduce the man-hours needed.

OBJECTS AND FEATURES OF THE INVENTION

[0007] A primary object and feature of the present invention is to overcome the above-mentioned problems and fulfill the above-mentioned needs.

[0008] Another object and feature of the present invention is to provide an apparatus and method for improved recovery of latent fingerprints on nonporous surfaces that can recover latent fingerprints that cannot be recovered by prior art means. Another object and feature of the present invention is to provide an apparatus and method for improved recovery of latent fingerprints on nonporous surfaces that uses an automatic controller. Another object and feature

of the present invention is to provide an apparatus and method for improved recovery of latent fingerprints on nonporous surfaces that is marketable and operates as a single unit, in which the user simply places an object suspected of having latent fingerprints into the chamber, and all operations take place in a single chamber under automatic control initiated with the push of a single button.

[0009] It is an additional primary object and feature of the present invention to provide an apparatus and method for improved recovery of latent fingerprints on nonporous surfaces that is safe, inexpensive, easy to clean, and handy. Other objects and features of this invention will become apparent with reference to the following descriptions.

SUMMARY OF THE INVENTION

[0010] In accordance with a preferred embodiment hereof, the present invention provides an apparatus for improved recovery of latent fingerprints on nonporous surfaces that can recover latent fingerprints that cannot be recovered by prior art means. The object that bears the fingerprint is first chilled and then exposed to atmospheric humidity to condense water onto the object and the fingerprint. The object, with condensation, is placed in the vacuum chamber and the chamber is pumped down towards vacuum after which the cyanoacrylate ester is flash heated. Based on the present inventor's discovery that, during exposure to vacuum, the condensation sticks longer to the sebaceous fluid which forms the finger print than to the object upon which the fingerprint rests, the cyanoacrylate ester flash heater is controlled to release cyanoacrylate ester vapors at a time when the condensation is still sticking to the sebaceous fluid but has evaporated from the object. The combination of moisture and sebaceous fluid retains the cyanoacrylate ester, providing recovery of fingerprints that would otherwise not be recoverable.

[0011] The controller employs a controller for operation of the vacuum pump and heater with monitoring of the time, internal chamber pressure, and heater temperature. The controller calculates the time to turn on the cyanoacrylate ester flash heater based on chamber pressure and turns on the cyanoacrylate ester flash heater. The controller also determines the time at which the process is complete and re-pressurizes the chamber.

[0012] The vacuum chamber has a door with a dual hinge arrangement that provides for a superior seal. In addition, the chamber features a sliding specimen tray that connects the flash heater to an outside source of electrical power when fully inserted into the chamber. The tray supports the flash heater.

BRIEF DESCRIPTION OF THE DRAWINGS

[0013] The above and other objects and advantages of the present invention will become more apparent from the following description taken in conjunction with the following drawings in which:

FIG. 1 is a front-side perspective view illustrating of an exemplary chamber for improved recovery of latent fingerprints on nonporous surfaces, according to a preferred embodiment of the present invention;

FIG. 2 is a front-side cutaway perspective view illustrating of an exemplary chamber for improved recovery of latent fingerprints on nonporous surfaces, according to a preferred embodiment of the present invention;

FIG. 3 is a front-side perspective view illustrating of an exemplary opened chamber for improved recovery of latent fingerprints on nonporous surfaces, according to a preferred embodiment of the present invention;

FIG. 4 is a front-side perspective view illustrating of an exemplary apparatus for improved recovery of latent fingerprints on nonporous surfaces, according to a preferred embodiment of the present invention;

FIG. 5 is a diagram illustrating the exemplary apparatus for improved recovery of latent fingerprints on nonporous surfaces, according to a preferred embodiment of the present invention;

FIG. 6 is a process diagram illustrating the method if using the exemplary apparatus for improved recovery of latent fingerprints on nonporous surfaces, according to a preferred embodiment of the present invention;

FIG. 7 is a front elevation view illustrating an exemplary back panel of a vacuum chamber of an exemplary apparatus for improved recovery of latent fingerprints on nonporous surfaces, according to a preferred embodiment of the present invention; and

FIG. 8 is a partial side cutaway view illustrating exemplary connections in an exemplary back panel of a vacuum chamber of an exemplary apparatus for improved recovery of latent fingerprints on nonporous surfaces, according to a preferred embodiment of the present invention.

DETAILED DESCRIPTION OF THE BEST MODES AND PREFERRED EMBODIMENTS OF THE INVENTION

[0014] FIG. 1 is a front-side perspective view illustrating of an exemplary chamber 100 for improved recovery of latent fingerprints on nonporous surfaces, according to a preferred embodiment of the present invention. Vacuum chamber 100, (hereinafter “chamber 100”)

includes housing 102 having a base 104, a door frame 106, and a door 108. Housing 102 is made sufficiently strong to avoid implosion under high vacuum. Housing 102 has a back panel 208 (see FIG. 2) having an inlet 204 (see FIG. 2) for vacuum supply, a coupling 702 (see FIG. 7) for electrical power for the flash heater 202 (see FIG. 2), and signal leads 522 (see FIG. 5) from an external controller 504 (see FIG. 5) to at least one sensor 704 (see FIG. 7) within chamber 100.

[0015] Door frame 106 is secured to front edges of housing 102 with vacuum tight joints. Door frame 106 supports four latches 124 (two of four visible in FIG. 1, one of two labeled) for securing door 108 to door frame 106 during operation of vacuum chamber 100. Door frame 106 also supports door hinge member support bracket 132. Door frame 106 provides a vacuum tight seal with door 108 when door 108 is closed and latched.

[0016] Door 108 has a transparent window 126, preferably an acrylic panel one inch thick, sealed along its edges to a window frame 120 that supports bosses 122 (two of four labeled), front-center hinges 112 and 114, and handles 110 (one of two labeled). Bosses 122 are engaged one-on-one by latches 124 to create a vacuum tight seal for the door 108 in the operational position. Hinges 112 and 114 are supported on the front exterior surface 134 of the window frame 120 and are flexibly coupled to first ends of door hinge members 116, respectively. Door hinge members 116 are also flexibly coupled at their second ends to door frame hinges 118 (one visible in this view). This dual-hinge arrangement allows the door 108 to be moved straight into the closed position, rather than being rotated into position as with conventional doors. The straight-in closure provides a better vacuum seal than is possible with hinged doors.

[0017] Specimen tray 128 rides on rails 302 and 304 (see FIG. 3) to extend for loading with a

specimen bearing a latent fingerprint to be detected and for supplying cyanoacrylate ester to the flash heater 202 (see FIG. 2). Specimen tray 128 has an indentation 130 for engaging a user's fingers for manually extending the specimen tray 128.

[0018] FIG. 2 is a front-side cutaway perspective view illustrating of an exemplary chamber 100 for improved recovery of latent fingerprints on nonporous surfaces, according to a preferred embodiment of the present invention. The right side (as the drawing is viewed) has been cut away to show features within the chamber 100. Flash heater 202 is a ceramic heater capable of rapid increases in temperature to 330°F. A thermal insulator panel 210 separates flash heater 202 from specimen tray 128 to prevent heat conduction into the specimen. Flash heater 202 can cool to ambient from 330°F in less than two minutes. In operation, an open-topped container made of heat conductive material is partially filled with cyanoacrylate and placed on top of flash heater 202. When the chamber 100 has been closed and pumped 508 (see FIG. 5) down to a predetermined vacuum, a controller 504 (see FIG. 5) turns on the flash heater 202 which vaporizes the cyanoacrylate, filling the chamber 100 with cyanoacrylate ester, which preferentially adheres to sebaceous material that makes up the ridges of the latent fingerprint, thereby enhancing the image of the fingerprint. The speed with which the cyanoacrylate is vaporized, as well as the timing of the vaporization, is important to the success of the operation.

[0019] Rear assembly 206 supports an electrical connector 702 (see FIG. 7) that couples with a complimentary electrical connector in specimen tray 128 when specimen tray 128 is positioned fully inside the chamber 100, as shown. Vacuum inlet 204 provides both vacuum supply and repressurization flow during the process cycle. A cross section of window 126 can be seen in FIG. 2.

[0020] FIG. 3 is a front-side perspective view illustrating of an exemplary opened chamber 100 for improved recovery of latent fingerprints on nonporous surfaces, according to a preferred embodiment of the present invention. Rails 302 and 304 are supported on base 104 and engage complimentary rail-riding devices on the bottom of specimen tray 128. The specimen tray 128 is stable for receiving specimens and cyanoacrylate when extended.

[0021] FIG. 4 is a front-side perspective view illustrating of an exemplary apparatus 400 for improved recovery of latent fingerprints on nonporous surfaces, according to a preferred embodiment of the present invention. The apparatus 400 includes chamber 100 and cabinet 402 along with user interface 404 supported on the outside of the cabinet 402 as well as equipment within cabinet 402, which will be discussed further in regard to FIG. 5. User interface 404 has one push button 406, a red light 408, a yellow light 410, and a green light 412. Green light 412 indicates that the inside of the chamber 100 is at atmospheric pressure and that dangerous levels of cyanoacrylate esters are not in the atmosphere within the chamber 100. The yellow light indicates either that the chamber 100 is pumping up or pumping down, and the red light indicates that the chamber 100 is at operational vacuum. Push button 406 initiates the controlled process of pumping down the chamber 100, flash heating the cyanoacrylate, waiting for deposition of the ester, and repressurizing the chamber 100.

[0022] FIG. 5 is a diagram illustrating the exemplary apparatus 400 for improved recovery of latent fingerprints on nonporous surfaces, according to a preferred embodiment of the present invention. Chamber 100 is connected, via vacuum hose 514, to vacuum pump 508 in cabinet 402. Vacuum pump 508 is preferably a 500 watt vacuum pump for a chamber 100 having dimensions of one foot width, two feet in length, and one and one-half feet in height. Output of

vacuum pump 508 goes through conduit 516 to filter 510 in cabinet 402. Filter 510 removes, among other things, cyanoacrylate ester from the air stream. The output of filter 510 is conducted via conduit 518 outside cabinet 402 as exhaust 512. Vacuum pump 508 is controlled over pump signal and vacuum power line 526 from controller 504. Electrical power is supplied via controller power line 528 to controller 504 from power supply 506. Controller 504 controls the distribution of power to the vacuum pump 508, to flash heater 202 via heater power line 520, to at least one sensor 502 via signal and power line 522, and to user interface 404, via interface power and signal line 524. Controller 504 includes a timer for measuring out predetermined wait times. At least one sensor 502 preferably includes a pressure sensor for measuring internal chamber pressure and a flash heater 202 temperature sensor.

[0023] FIG. 6 is a process diagram illustrating the method 600 of using the exemplary apparatus 400 for improved recovery of latent fingerprints on nonporous surfaces, according to a preferred embodiment of the present invention. In step 602, the specimen bearing the latent print is chilled, preferably in a conventional refrigerator. In step 604, the chilled specimen is exposed to humidity. The humidity in an ordinary office building or forensics laboratory is generally sufficient. Water from the humidity condenses on the specimen and the latent print. In step 606, the chilled and exposed specimen is placed on specimen tray 128, cyanoacrylate is placed in an open-topped container on the flash heater 202, the specimen tray 128 is slid fully into the chamber 100, and door 108 is closed and secured with latches 124. In step 608, the user presses push button 406 to initiate the process. The process proceeds under automatic control of the controller 504 by pumping 508 the chamber 100 to vacuum and applying power to flash heater 202 to vaporize the cyanoacrylate at a time when the condensed water has evaporated off the

specimen but not completely off the sebaceous material that forms the ridges of the fingerprint. In step 610, the process waits a predetermined time for the cyanoacrylate to bind with the wetted sebaceous material and then repressurizes the chamber 100. When the green light 412 comes on, latches 124 are released, door 108 is opened, and the specimen is manually removed from the chamber. In step 614, the image of the latent fingerprint is observed to determine what further action, if any, is appropriate.

[0024] FIG. 7 is a front elevation view illustrating an exemplary back panel 208 of a vacuum chamber 100 of an exemplary apparatus 400 for improved recovery of latent fingerprints on nonporous surfaces, according to a preferred embodiment of the present invention. Electrical coupling 702, which is preferably an RCA jack, for flash heater 202 is supported in an alignment key 708 on rear assembly 206. Alignment key 708 interacts with a complimentary cavity shape in the underside of specimen tray 128 to ensure alignment of the flash heater RCA connector (not shown) on the specimen tray 128 with electrical coupling 702. At least one sensor 502 and 706 are also supported on the rear assembly 206. The positions shown are exemplary, and are not a limitation of the invention.

[0025] FIG. 8 is a partial side cutaway view illustrating exemplary connections 802, 808, and 810 in an exemplary back panel 208 of a vacuum chamber 100 of an exemplary apparatus 400 for improved recovery of latent fingerprints on nonporous surfaces, according to a preferred embodiment of the present invention. Vacuum inlet 204 attaches to sealed through-coupling 802 and external fluid coupling 804, which receives vacuum line 514. Heater power line 520 attaches to external electrical coupling 808 which is in electrical communication with sealed through-coupling 806 and internal conductor 812 through rear assembly 206 and alignment key

708 to coupling 702. Signal leads 522 couple to external sensor coupling 810 and extend inwardly through rear assembly 206 and alignment key 708 to sensor 706.

[0026] Although applicant has described applicant's preferred embodiments of this invention, it will be understood that the broadest scope of this invention includes such modifications as diverse shapes and sizes and materials. Such scope is limited only by the below claims as read in connection with the above specification. Further, many other advantages of applicant's invention will be apparent to those skilled in the art from the above descriptions and the below claims.

Claims

I claim:

1. An apparatus for recovering a latent fingerprint that is on an object, the apparatus comprising:
 - a. a vacuum chamber; and
 - b. a flash heater inside said vacuum chamber.
2. The apparatus of claim 1, wherein said vacuum chamber comprises:
 - a. a specimen tray that is mounted on rails for:
 - i. sliding into and out of said vacuum chamber;
 - ii. supporting said flash heater; and
 - iii. supporting electrical connection between said flash heater and an electrical power supply; and
 - b. at least one sensor.
3. The apparatus of claim 1, wherein said vacuum chamber comprises a window door having a window frame and first and second door hinges attached to a front exterior surface of said window frame.
4. The apparatus of claim 3, wherein said vacuum chamber comprises a door frame having first and second frame hinges attached to said door frame.
5. The apparatus of claim 4, having first and second connecting members coupling said first and second door hinges to said first and second frame hinges, respectively.
6. The apparatus of claim 1, further comprising a cabinet supporting said vacuum chamber, wherein said cabinet supports a user interface on an exterior wall of said cabinet.

7. The apparatus of claim 6, wherein said cabinet internally supports:
 - a. a vacuum pump fluidically coupled to said vacuum chamber;
 - b. a filter fluidically coupled to said vacuum pump;
 - c. a power supply electrically coupled at least to a controller within said cabinet; and
 - d. said controller operable to be electrically coupled to at least two of:
 - i. said user interface;
 - ii. said vacuum pump;
 - iii. said power supply;
 - iv. said flash heater; and
 - v. at least one sensor in said vacuum chamber.
8. The apparatus of claim 1, further comprising at least one sensor within said vacuum chamber.
9. The apparatus of claim 1, further comprising a controller, operable to control:
 - a. a vacuum supply coupled to said vacuum chamber;
 - b. an electrical supply coupled to said flash heater; and
 - c. responsive to at least one of a push button on a user interface, a pressure sensor within said vacuum chamber, a temperature sensor within said vacuum chamber, and a timer within said controller.
10. The apparatus of claim 2, wherein said vacuum chamber further comprises a thermally insulating panel operable to insulate said flash heater from said specimen tray.
11. The apparatus of claim 2, further comprising a rear assembly within said vacuum chamber supporting:

- a. an electrical coupling within an alignment key, wherein said coupling is coupled to said flash heater only when said specimen tray is fully inserted into said vacuum chamber; and
 - b. said at least one sensor.
12. The apparatus of claim 1, wherein said vacuum chamber is controllable to:
- a. evaporate condensed water from a specimen in said vacuum chamber without fully evaporating water from sebaceous material forming ridges of a fingerprint on such specimen, resulting in a condensation-hydrated fingerprint; and
 - b. expose such condensation-hydrated fingerprint on such specimen in said vacuum chamber to cyanoacrylate ester for a period of time sufficient to adhere said cyanoacrylate ester to such condensation-hydrated fingerprint.
13. An apparatus for recovering a latent fingerprint that is on a specimen, the apparatus comprising:
- a. a vacuum chamber;
 - b. a flash heater inside said vacuum chamber; and
 - c. wherein said vacuum chamber comprises a specimen tray that is mounted on rails for:
 - i. sliding into and out of said vacuum chamber;
 - ii. supporting said flash heater; and
 - iii. supporting electrical connection between said flash heater and an electrical power supply.
14. The apparatus of claim 13, further comprising a controller, operable to control:

- a. a vacuum supply coupled to said vacuum chamber;
 - b. an electrical supply coupled to said flash heater; and
 - c. responsive to at least one of a push button on a user interface, a pressure sensor within said vacuum chamber, a temperature sensor within said vacuum chamber, and a timer within said controller.
15. The apparatus of claim 14, wherein said vacuum chamber is controllable by said controller to:
- a. evaporate condensed water from a specimen in said vacuum chamber without fully evaporating water from sebaceous material forming ridges of a fingerprint on such specimen, resulting in a condensation-hydrated fingerprint; and
 - b. expose such condensation-hydrated fingerprint on such specimen in said vacuum chamber to cyanoacrylate ester for a period of time sufficient to adhere a visible amount of said cyanoacrylate ester to such condensation-hydrated fingerprint.
16. The apparatus of claim 1, further comprising a cabinet supporting said vacuum chamber, wherein said cabinet supports a user interface on an exterior wall of said cabinet; wherein said cabinet internally supports:
- a. a vacuum pump fluidically coupled to said vacuum chamber;
 - b. a filter fluidically coupled to said vacuum pump;
 - c. a power supply electrically coupled at least to a controller within said cabinet; and
 - d. said controller operable to be electrically in communication with at least two of:
 - i. said user interface;
 - ii. said vacuum pump;

- iii. said power supply;
- iv. said flash heater; and
- v. at least one sensor in said vacuum chamber.

17. The apparatus of claim 13, wherein said vacuum chamber comprises:

- a. a window door having a window frame and first and second door hinges attached to a front exterior surface of said window frame;
- b. a door frame of said vacuum chamber having first and second frame hinges attached to said door frame; and
- c. first and second connecting members coupling said first and second door hinges to said first and second frame hinges, respectively.

18. The apparatus of claim 16, further comprising a rear assembly within said vacuum chamber supporting:

- a. an electrical coupling within an alignment key, wherein said coupling is coupled to said flash heater only when said specimen tray is fully inserted into said vacuum chamber; and
- b. said at least one sensor.

19. An apparatus for recovering a latent fingerprint that is on a specimen, the apparatus comprising:

- a. a vacuum chamber;
- b. a flash heater inside said vacuum chamber;
- c. wherein said vacuum chamber comprises a specimen tray that is mounted on rails for:

- i. sliding into and out of said vacuum chamber;
 - ii. supporting said flash heater; and
 - iii. supporting electrical connection between said flash heater and an electrical power supply;
- d. a controller, operable to control:
 - i. a vacuum supply coupled to said vacuum chamber;
 - ii. an electrical supply coupled to said flash heater; and
 - iii. responsive to at least one of a push button on a user interface, a pressure sensor within said vacuum chamber, a temperature sensor within said vacuum chamber, and a timer within said controller; and
- e. wherein said vacuum chamber is controllable by said controller to:
 - i. evaporate condensed water from a specimen in said vacuum chamber without fully evaporating water from sebaceous material forming ridges of a fingerprint on such specimen, resulting in a condensation-hydrated fingerprint; and
 - ii. expose such condensation-hydrated fingerprint on such specimen in said vacuum chamber to cyanoacrylate ester for a period of time sufficient to adhere a visible amount of said cyanoacrylate ester to such condensation-hydrated fingerprint.

20. The apparatus of claim 19, wherein said vacuum chamber comprises:

- a. a window door having a window frame and first and second door hinges attached to a front exterior surface of said window frame;

- b. a door frame of said vacuum chamber having first and second frame hinges attached to said door frame;
- c. first and second connecting members coupling said first and second door hinges to said first and second window frame hinges, respectively; and
- d. a rear assembly within said vacuum chamber supporting:
 - i. an electrical coupling within an alignment key, wherein said coupling is coupled to said flash heater only when said specimen tray is fully inserted into said vacuum chamber; and
 - ii. at least one of said pressure sensor and said temperature sensor.

1/7

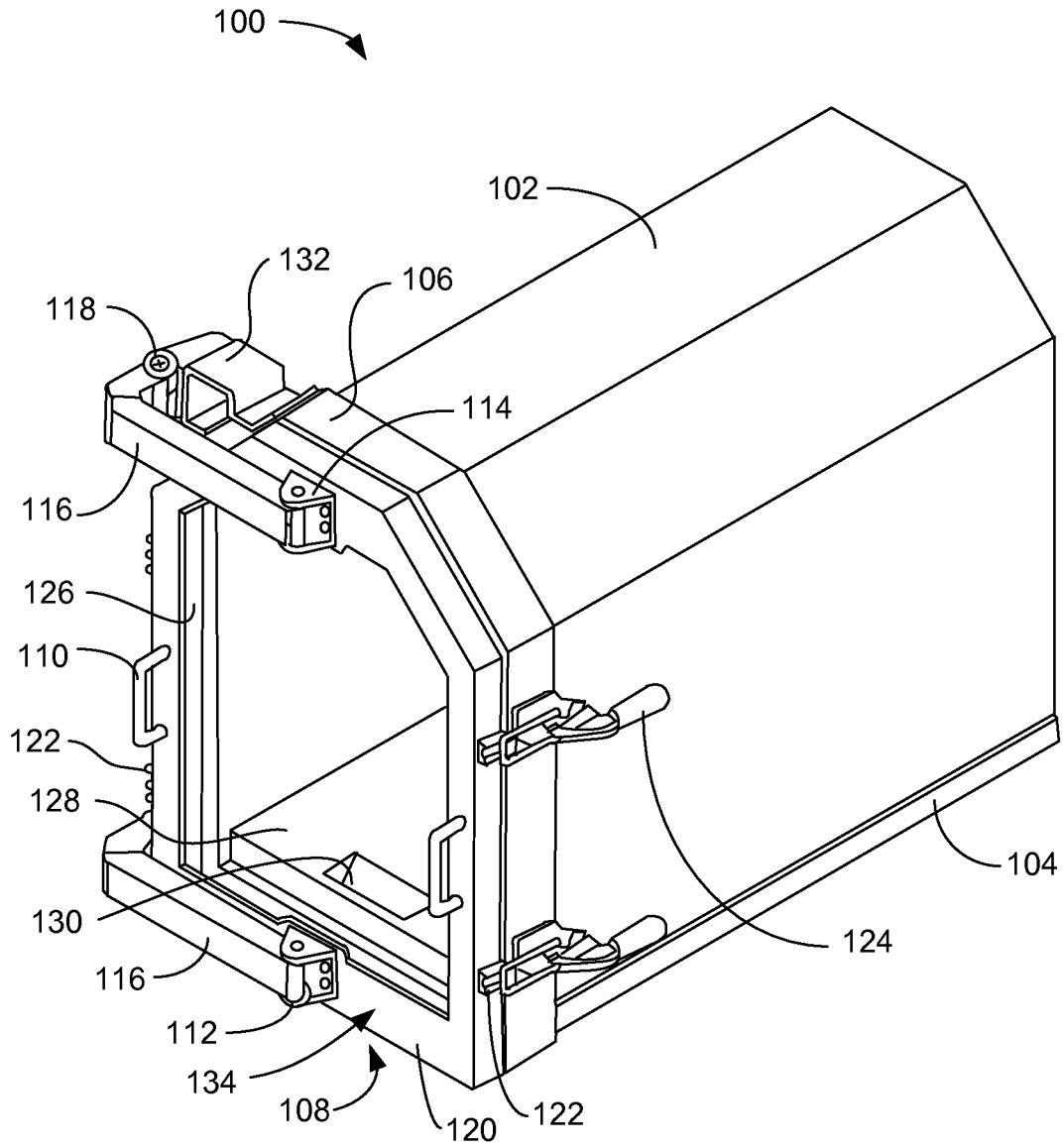

FIG. 1

2/7

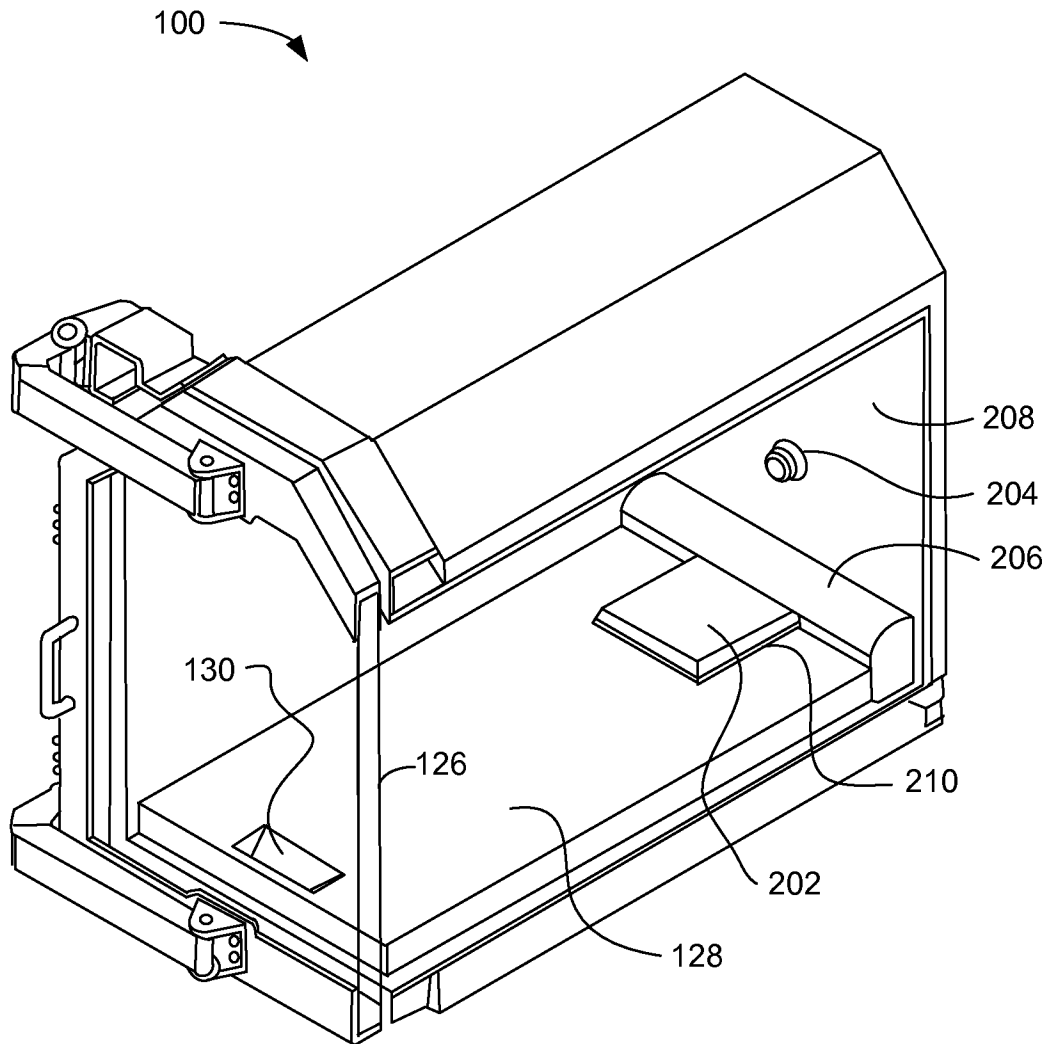

FIG. 2

3/7

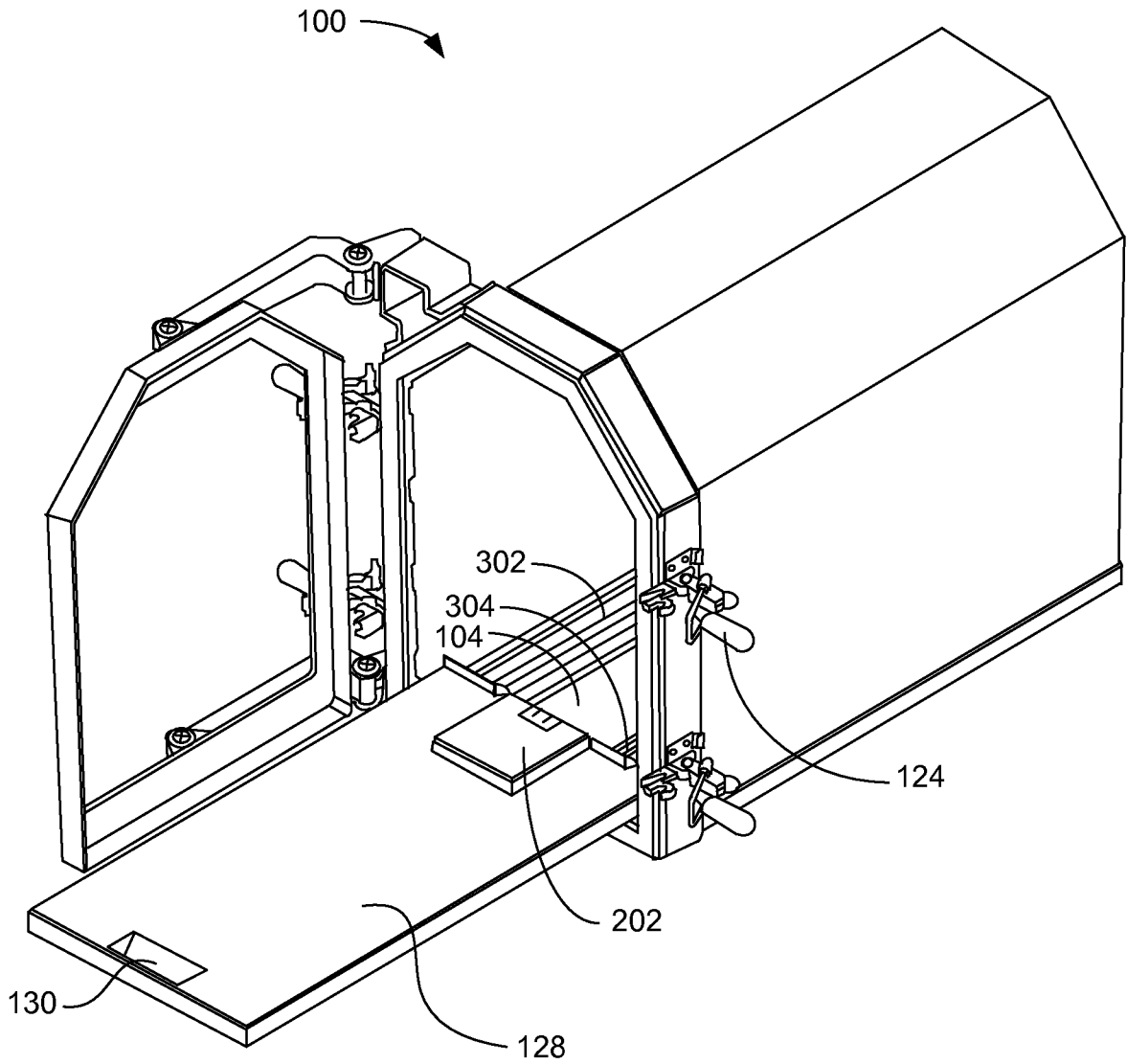

FIG. 3

4/7

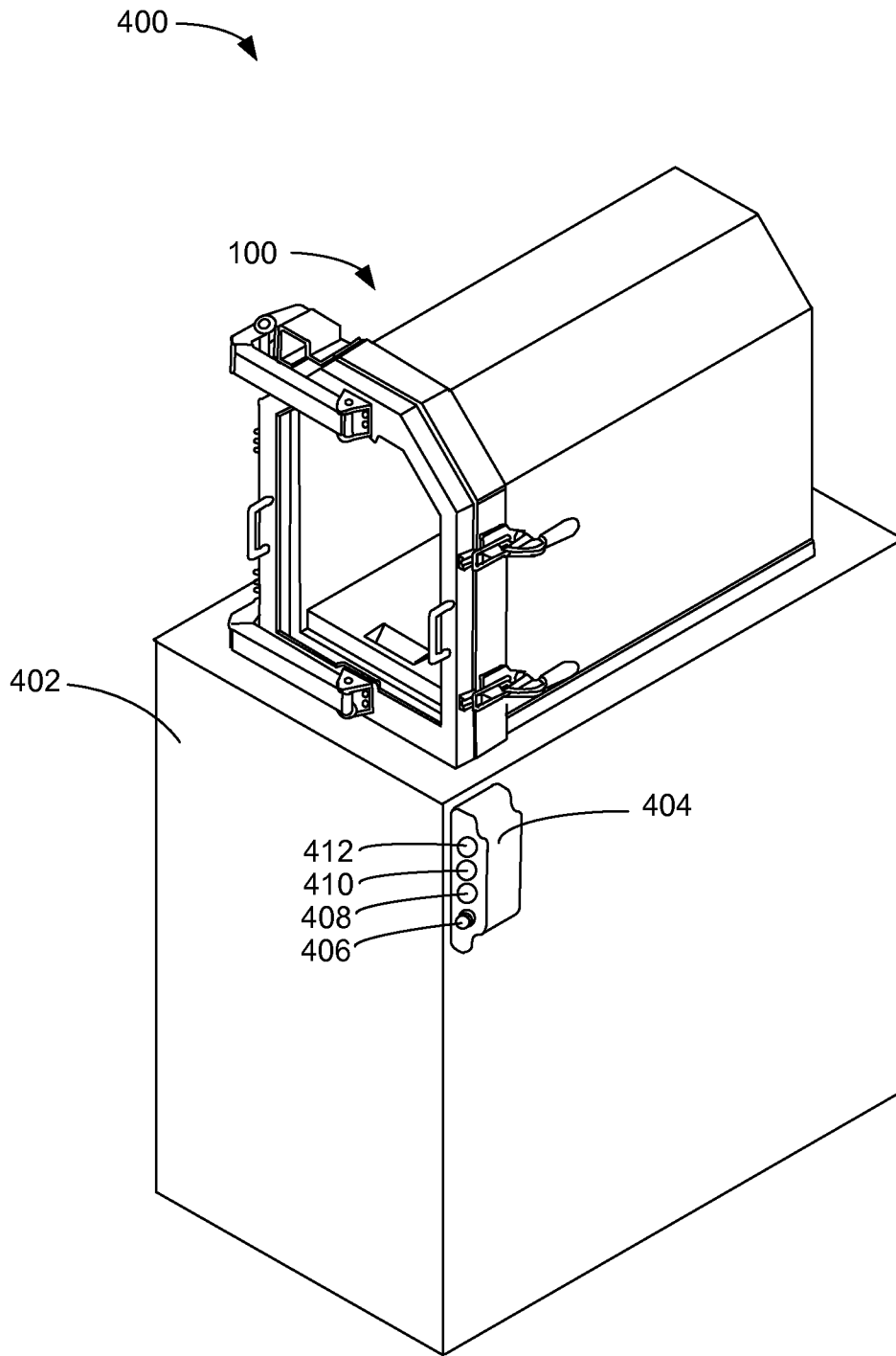

FIG. 4

5/7

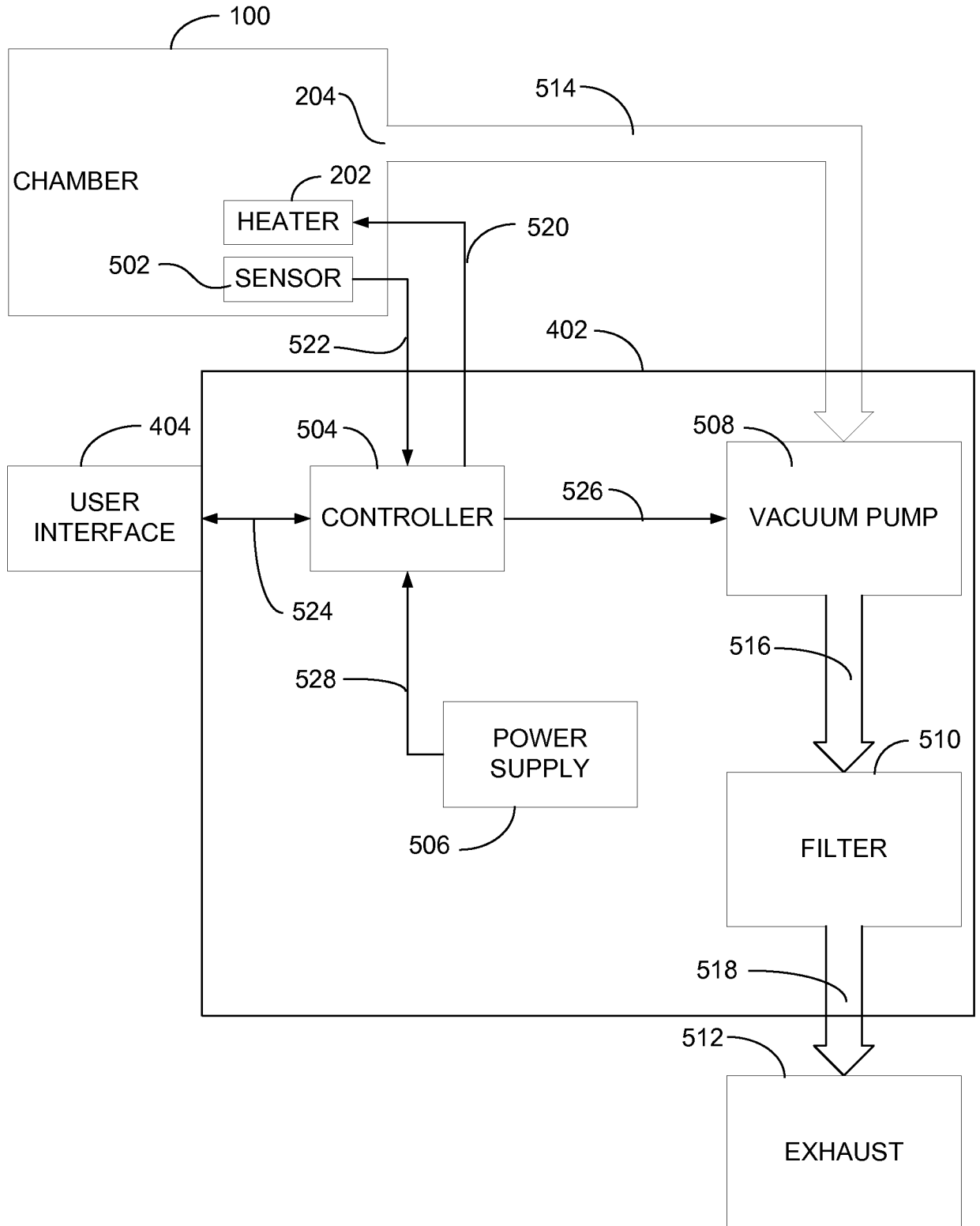

FIG. 5

6/7

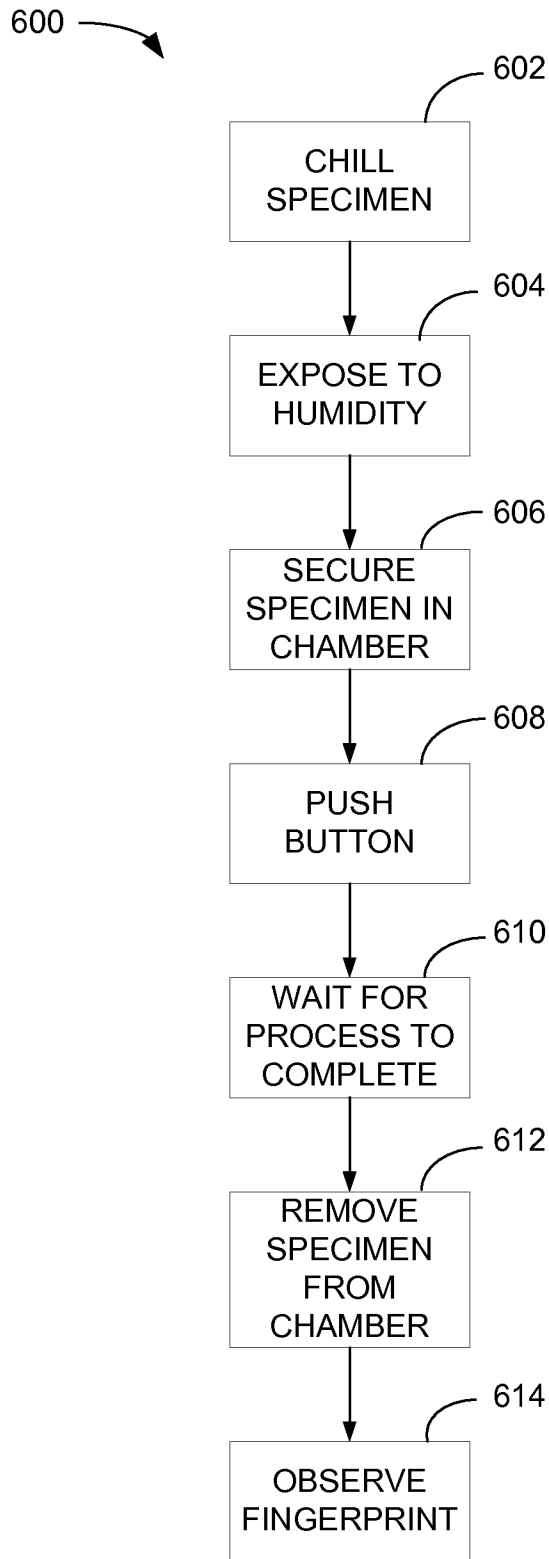

FIG. 6

7/7

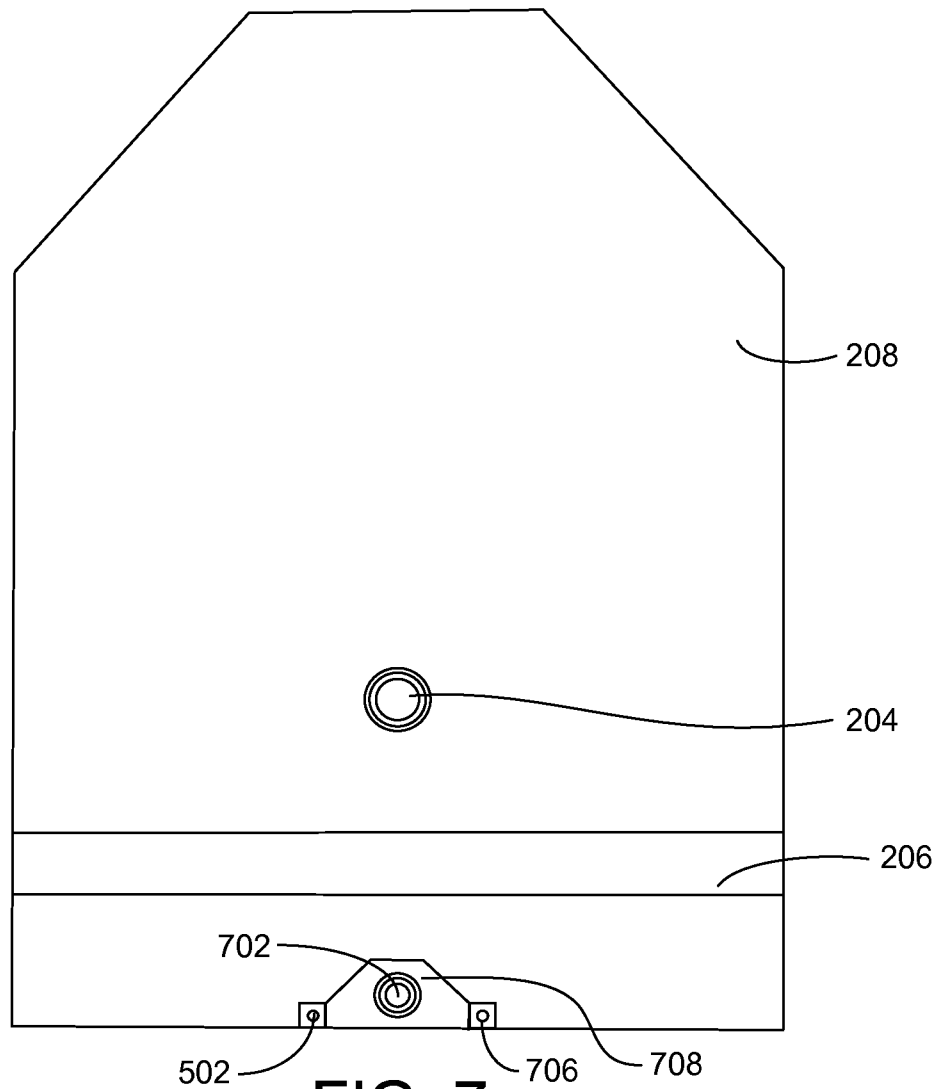

FIG. 7

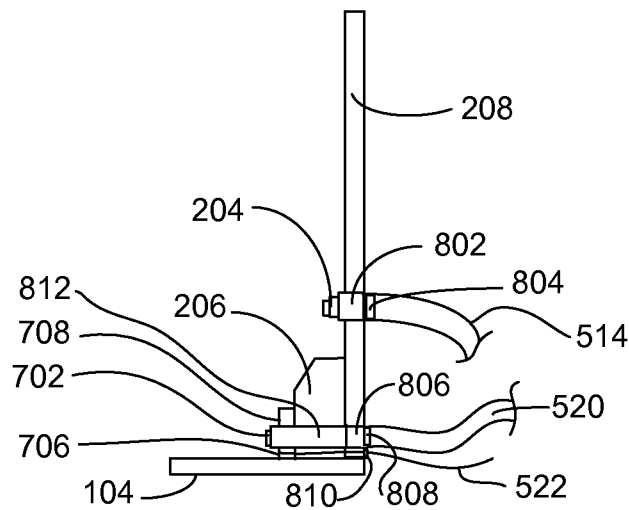

FIG. 8

INTERNATIONAL SEARCH REPORT

International application No.
PCT/US 13/31801

A. CLASSIFICATION OF SUBJECT MATTER
IPC(8) - B41M 5/00 (2013.01)
USPC - 427/145
According to International Patent Classification (IPC) or to both national classification and IPC

B. FIELDS SEARCHED
Minimum documentation searched (classification system followed by classification symbols)
USPC: 427/145

Documentation searched other than minimum documentation to the extent that such documents are included in the fields searched
USPC: 427/145; 118/50; 118/697; 118/702; all classes; NPL (text search - see terms below)

Electronic data base consulted during the international search (name of data base and, where practicable, search terms used)
PatBase; PubWEST(USPT,PGPB,EPAB,JPAB); Google
Search Terms Used: fingerprint, vacuum, flash heater, heater, tray, rails vacuum chamber, specimen tray, sample tray, door frame, cabinet, window

C. DOCUMENTS CONSIDERED TO BE RELEVANT

Category*	Citation of document, with indication, where appropriate, of the relevant passages	Relevant to claim No.
X - Y	US 2012/0141669 A1 (Stones) 07 June 2012 (07.06.2012), entire document especially Abstract; paras [0021], [0033], [0036], [0039]	1, 8, 9, 12 ----- 2-7, 10, 11, 13-20
Y	US 4,205,623 A (Mahi) 03 June 1980 (03.06.1980), entire document especially Fig 1; col 1, lns 31-41; col 2, lns 29-33	6, 7, 16, 18
Y	WO 2012/089734 A2 (Van Boven) 05 July 2012 (05.07.2012), pg 1-2; fig 1	3-5, 17, 20
Y	US 4,233,780 A (Royce) 18 November 1980 (18.11.1980), entire document especially Fig 1; col 2, lns 9-14	3-5, 17, 20
Y	US 2010/0187201 A1 (Fukuoka et al.) 29 July 2010 (29.07.2010), para [0038], [0111], [0112], [0124], [0125]	2, 10, 11, 13-20
Y	US 4,131,789 A (Tyler) 26 December 1978 (26.12.1978), abstract; col 2, ln 16-37; col 4, ln 35-52	2, 10, 11, 13-20
A	US 5,537,507 A (Mariner et al.) 16 July 1996 (16.07.1996), entire document	1-20
A	US 3,970,820 A (Mahi) 20 July 1976 (20.07.1976), abstract	1-20
A	US 6,423,946 B1 (Berka et al.) 23 July 2002 (23.07.2002), entire document	1-20
A	US 4,033,904 A (Gerlach et al.) 05 July 1977 (05.07.1977), entire document especially Fig 2; col 2, lns 66-69	1-20

Further documents are listed in the continuation of Box C.

* Special categories of cited documents:	"T" later document published after the international filing date or priority date and not in conflict with the application but cited to understand the principle or theory underlying the invention
"A" document defining the general state of the art which is not considered to be of particular relevance	"X" document of particular relevance; the claimed invention cannot be considered novel or cannot be considered to involve an inventive step when the document is taken alone
"E" earlier application or patent but published on or after the international filing date	"Y" document of particular relevance; the claimed invention cannot be considered to involve an inventive step when the document is combined with one or more other such documents, such combination being obvious to a person skilled in the art
"L" document which may throw doubts on priority claim(s) or which is cited to establish the publication date of another citation or other special reason (as specified)	"&" document member of the same patent family
"O" document referring to an oral disclosure, use, exhibition or other means	
"P" document published prior to the international filing date but later than the priority date claimed	

Date of the actual completion of the international search 08 May 2013 (08.05.2013)	Date of mailing of the international search report 19 JUN 2013
---	--

Name and mailing address of the ISA/US Mail Stop PCT, Attn: ISA/US, Commissioner for Patents P.O. Box 1450, Alexandria, Virginia 22313-1450 Facsimile No. 571-273-3201	Authorized officer: Lee W. Young PCT Helpdesk: 571-272-4300 PCT OSP: 571-272-7774
---	--