

John More

Sliding Door.

111468

PATENTED JAN 31 1871

Fig. 1.

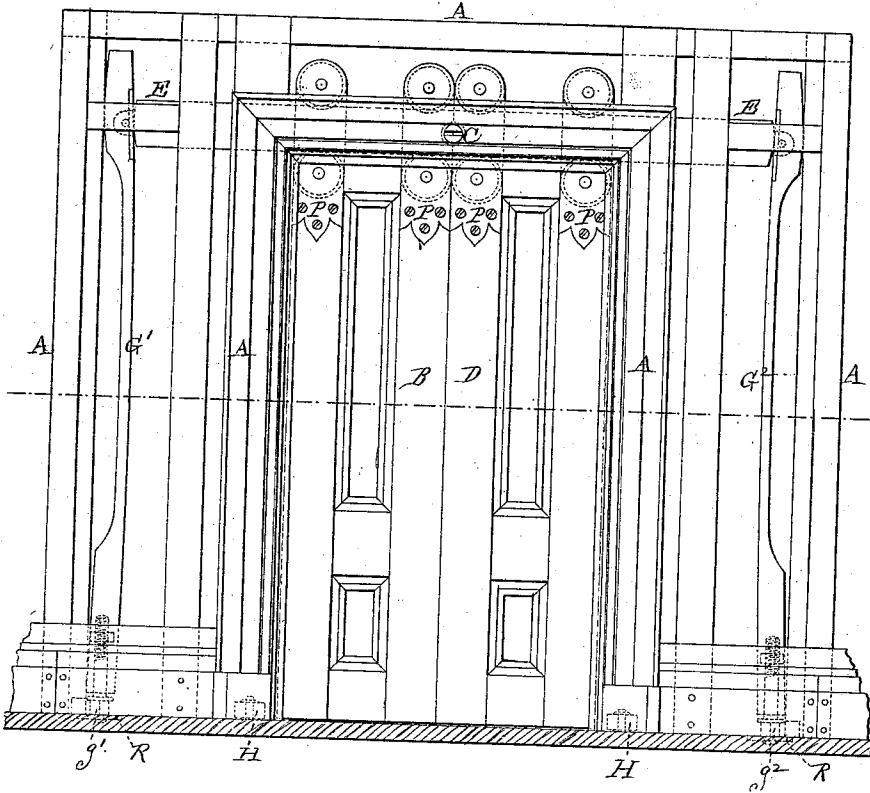
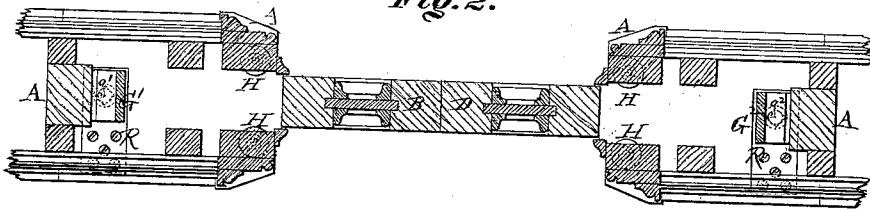

Fig. 2.



Witnesses.

*C. C. Living*  
*Wm. C. Day*

Inventor.

*John More*  
 by his attorney  
*J. D. Stetson.*

*John More*

*Sheet 2.*  
**Sliding Door.**

111468

PATENTED JAN 31 1871

*Fig. 3.*

*Fig. 4.*

*Fig. 5.*

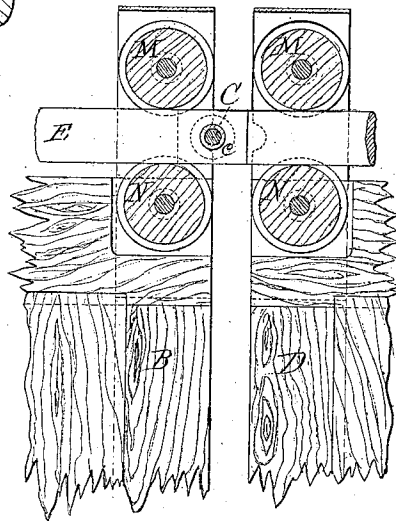
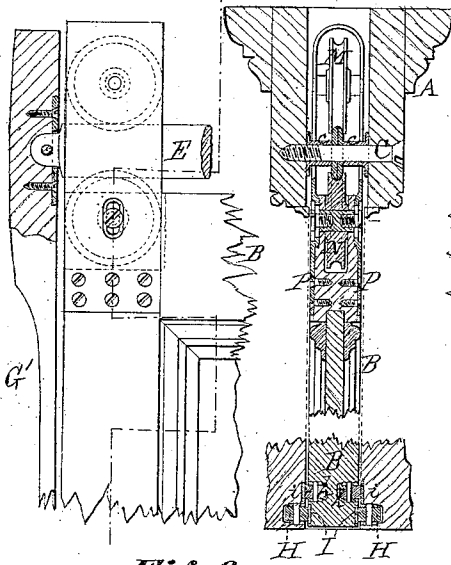

*Fig. 6.*

*Fig. 7.*

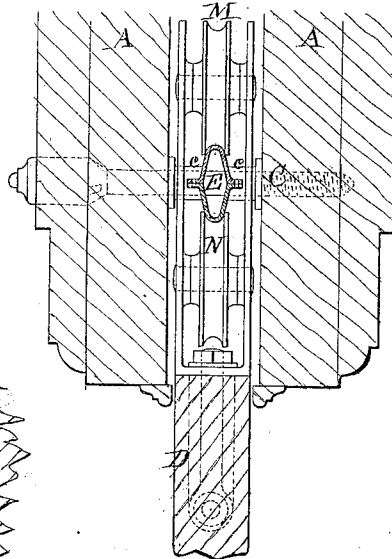
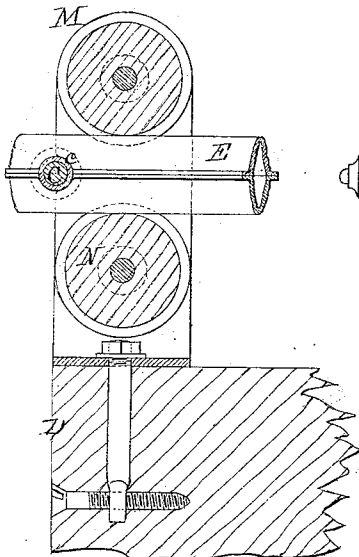

*Witnesses.*

*Fig. 8.*

*Inventor.*

*C. C. Livings*  
*Wm. C. Day*

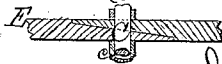

*John More*  
*by his atty J. D. Stetson*

# United States Patent Office.

JOHN MORE, OF NEW YORK, N. Y.

Letters Patent No. 111,468, dated January 31, 1871.

## IMPROVEMENT IN SLIDING-DOORS.

The Schedule referred to in these Letters Patent and making part of the same.

### To all whom it may concern:

Be it known that I, JOHN MORE, of the firm of Duke & More, builders, New York city, have invented certain new and useful Improvements in the Means of Hanging and Operating Sliding-Doors; and I do hereby declare that the following is a full and exact description thereof.

My invention, or some parts thereof, may be used with advantage in all situations where sliding-doors are employed, whether double or single, but it is more especially intended for double sliding-doors, opening by separating and sliding in opposite directions from a central line, and where, as in parlors, the length or height of the door of each part is great, relatively, to its breadth.

My doors are hung on sheaves or pulleys traversing on a rail extending across overhead and concealed in the casing.

This general arrangement has been common, but I provide means for overcoming several difficulties which have heretofore attended this class of work.

I will first proceed to describe what I consider the best means of carrying out my invention, and will afterward designate the points which I believe to be new therein.

The accompanying drawing forms a part of this specification.

Figure 1 is a side elevation of the doors and of the frame-work, with a portion of the fixed framing or casing removed, to show the arrangement of the supporting-bar, the sheaves, springs, adjusting means, &c.

Figure 2 is a horizontal section on the line S S, in fig. 1. The doors and the casing are represented thicker than will be generally constructed in practice.

Figures 3 to 8 represent details and modifications on a larger scale.

Figure 3 is a side elevation representing a portion of the door and the adjacent parts, with the door in the extreme withdrawn position. That is to say, it represents the upper back corner of the door, and the corresponding portion of the supporting-bar or way, with the upper end of a piece which serves the double function of holding up the way, and cushioning or gently stopping the door when it is slid back.

Figure 4 is a vertical section on several different planes. The parts are sectioned so as to show the exact details of construction to as full an extent as possible in a single figure. The upper portion is in the plane of a central bolt, (seen also in fig. 1, and several other figures.) Next below this the plane changes, and is taken through one of the sheaves. Afterward the plane changes again twice. The change of plane is indicated in dotted lines in fig. 3.

The figure, fig. 4, represents the chief peculiarities both at the top and bottom of the door.

Figure 5 represents the upper front corners of both parts of the door, or of both the doors with the adjacent portion of the supporting-way. In this figure the doors are represented as nearly closed.

Figure 6 represents the front upper corner of one of the doors in section. It shows the means which I propose to employ for connecting the sheaves and their housings to the door, to avoid the necessity for any external metal to appear on the face of the door.

Figure 7 is a cross-section corresponding to fig. 6. In figs. 5 and 6 the supporting-way is represented as hollow.

Figure 8 is a horizontal section of a small portion on a higher plane. It represents a section along the center of the supporting-bar or way on which the door is carried.

Similar letters of reference indicate like parts in all the figures.

A is the fixed frame-work and casing, which surrounds the door and conceals the sheaves, supporting-way, spring-strut, side sheaves, &c., so that my doors shall present only the appearance of the approved constructions of such doors.

B D are the doors or the parts which, moving independently and separating and drawing together as required, form the double door.

C is a central bolt, which forms a stop to prevent either part, B or D, from being moved out too far, and also aids in supporting the way.

The doors are recessed to match against the bolt C, or rather against the surrounding thimble, c, as represented in fig. 5.

E is a rail or stout bar, of rolled iron or other suitable material, which forms the way upon which the sheaves run.

It is supported at the center by the bolt C, and at each end by curved spring-struts, G<sup>1</sup> G<sup>2</sup>, in the manner indicated in figs. 1, 2, and 3.

The connection of each end of the way E to the adjacent surface of the strut is simple, and will be readily understood from the figure.

The connection of the curved struts G<sup>1</sup> G<sup>2</sup> to the other parts at the base is peculiar, and allows of delicate adjustment.

The weight is supported on the rounded head of a stout screw, g<sup>1</sup> g<sup>2</sup>, the thread of which takes in a nut set in the wood, as indicated in dotted lines.

When it is found that the way is a little settled at either end, a provision, not represented, being made in the casing for obtaining access to these parts, the screw g<sup>1</sup> or g<sup>2</sup> is turned sufficiently to raise the strut with its connections.

An opposite adjustment will of course lower the way at either end.

Under ordinary circumstances no special provision is necessary for raising and lowering the central bolt

C. I adjust this by ordinary means, making a new hole therefor, or elongating the old hole upward, and blocking up the bolt firmly, as will be obvious.

I guide the bottom edge of the doors by small anti-friction pulleys; I can provide these either on the door or on the casing, or both. They are mounted on vertical axes, and adapted to turn freely. Their form may be plain cylindrical, or a little swelled or barrel-shaped.

Fig. 4 shows a set of these rollers on the door, and also a corresponding set on the casing.

The rollers on the casing are marked H H, and they work against a corresponding bar or plate of brass, or other suitable material, on the door, marked I.

The set of rollers carried on the door is marked h h. They work against a corresponding bar or plate of iron, or other suitable material, on the interior of the casing, marked i.

In figs. 1 and 2 the rollers on the casing alone are represented, and in these figures the bar I on the door is omitted.

As either door is moved out and in the rollers H h serve to guide the door without allowing it to rub against the casing. They do not aid in supporting but only in guiding the door laterally.

There are two sets of sheaves at the top, both mounted on the parts of the door and traveling out and in therewith.

The upper set runs on the top of the way and supports the weight of the door.

The under set performs an important function which becomes more important in proportion as the height of the door is increased and its width narrowed.

It serves to prevent the door from assuming an inclined position; that is, when the pressure of the hand or any other force is applied near the base of the front edge of the door to push it suddenly back, the inertia of the mass of the door above, and the friction which may attend the operation of the sheaves or any other part near the top by holding back the upper portion of the door, and allowing the bottom alone to be pushed back, may throw up the back sheave and incline the whole door into a cornerwise and jammed position.

This is always liable to occur with doors as ordinarily mounted, and is particularly observable on the doors of horse-cars, and in any position where a high and narrow door is employed, running on rollers or sheaves at the top.

My lower set of sheaves traverses in contact with the lower side of the way or supporting-bar E, and resists any tendency of either the front or back edge of the door to rise.

Between the two sets of sheaves the door is rigidly held in its perfectly upright position, and moves out and in standing exactly upright.

I have marked the sheaves in the upper series M M, and the sheaves in the lower series N N.

They are mounted on the several pivots or central bolts m n, which are supported in the straps P, fixed on the upper portion of the door. I have represented two of these straps on each door, one at the front upper corner, and the other at the back upper corner, but there may be three of these straps, or any other number desired, on each portion of the door. Each of the straps carries two of the sheaves; that is, one sheave in the upper series and one sheave in the lower series.

When the door is moved violently back it is liable to strike with great force, so as to injure itself or the part against which it strikes. Sometimes the plastering of the adjacent parts of the room on one side or both sides of the door is severely strained and cracked by the repeated concussions due to this cause. It is customary to employ stops, but such stops are rigid

and unyielding. They have been solid masses of wood or metal.

I stop my doors gently and elastically by causing them to strike against the curved sides of the struts before described; that is to say, the part B of the door, when it moves back to its full extent, strikes the rounded face or side of the strut G<sup>1</sup>, and, by straightening it a little, receives an elastic resistance, and is gently stopped.

The same effect is produced by the strut G<sup>2</sup> against the part D of the door when it is moved back.

I sometimes term these parts G<sup>1</sup> G<sup>2</sup> supporting-posts or spring bars, the former referring entirely to the function of supporting and adjusting the height of the way, and the latter referring alone to their function of gently arresting the door. They perform both functions.

Although I have above called them curved struts, suggesting the idea of both functions in the single term, it will be obvious that it is not an essential requisite that they shall be curved; thus, for example, if the struts G<sup>1</sup> G<sup>2</sup> were straight, with freedom to bend back in the middle, and the striking-edge of the door were rounded, an effect corresponding very nearly with that of the curved form of the strut is produced. So, also, an analogous effect may be produced by simply glueing, screwing, or otherwise fixing a block or mass of wood or other suitable material at or near the middle of the height either of the strut G<sup>1</sup> G<sup>2</sup> or of the edge of the door. These and various other modifications may be made by any good mechanic. I prefer to cut out a portion of the thickness of each strut, as represented, so as to increase its yielding qualities, but this may not be absolutely necessary under all circumstances, especially with very heavy doors, as in barns, ware-houses, depots, and the like.

To more conveniently insert the bar E, I make it in two pieces, halved together on the bolt C, as shown in fig. 8.

I have described how my invention allows for correcting the positions of the doors in case of settling or derangement after they are mounted. It also aids in fitting the doors in the first place.

My invention allows the doors to be entirely finished and fitted in the shop. They are put in place by being properly mounted on the bar E. With either of the forms of straps P the sheaves may be reeved upon the supporting-way E, and the latter put in its place, temporarily adjusting it at a height a little above that which it is finally to assume, and leaving out the central bolt C. Now, supposing we employ only two straps, P, on each part of the door, as here represented, we open them to a greater distance apart than the width of the part to which they are to be fitted. Then the part B, being brought from the shop and placed in the door-frame A, the straps P can be moved into their proper position and firmly secured by screws or otherwise, the door being meanwhile lifted a little at the bottom by wedges or any other convenient means. Now this part of the door is mounted, and on being thrust back into its recess in the casing, the straps P, with their two sets of sheaves for the other part D, are correspondingly moved along on the bar or the way E and separated to receive the other part D of the door between them. Both being fitted and shoved back into their recesses, the bolt C, with its enveloping thimbles c, are put in place, and on lowering the spring-struts G<sup>1</sup> G<sup>2</sup> by the screws g<sup>1</sup> g<sup>2</sup>, as before described, the doors are nicely and accurately adjusted without any planing or other fitting.

I can ornament the head of the bolt C, or can cover it with any convenient ornament, as indicated in fig. 7.

I can secure the straps P by bolts p extending down into the wood and receiving cross-bolts p', as represented in figs. 6 and 7, and thus avoid presenting to

the eye any of the metal of the straps when the door is in use.

I can make the bar or way E in a single piece, as indicated in fig. 5 and the preceding figures, or in two pieces rolled hollow, as in figs. 6 and 7.

I esteem it important to mount each of the sheaves N in slots, as represented in figs. 3 and 4, so that they may be adjusted up and down within considerable limits to allow for variations in the size of the ways upon which they are applied, or for tightening up when they become loose from wear or other cause.

Modifications may be made in many of the details without departing from the principle of my invention. I have indicated the forms which, from my experience in constructing and finishing elegant dwellings, I judge to be most expedient in practice. I introduce a bearing-plate or metallic plate, R, under the rounded head of each adjusting screw  $g^1$   $g^2$ . I esteem this important in any case where heavy doors are to be supported, and still more so when the building is liable to settle from time to time, or become distorted so as to require frequent adjusting of the screws. The metal plate affords a broad, firm, and durable bearing for the screw-head.

There is a difficulty in the way of introducing the bar E in the continuous length, which my above-described modes of construction and fitting does not entirely overcome. It is highly desirable to postpone the introduction of the bar or way E and of the corresponding sheaves and straps until after the door-frame and the adjacent plastering is finished; and it is especially desirable also to be able to remove all these parts for repairs or for the substitution of new parts, without destroying any considerable portion of the casing and the adjacent parts in the building.

I accomplish all these ends by making the bar or way E in two distinct pieces, halved together upon the central bolt C, as represented in fig. 8. By this construction, which is preferably applied with the solid form of the bar, as shown in figs. 1 to 5, but may be

also applied to the hollow construction, I am able to introduce each half separately, and to afterward properly secure them together and to the central bolt C in the middle.

It will now be understood that the bar or way E, wherever it has been referred to in this specification, may be made in a single piece, and may serve with tolerable success so constructed, but that I esteem it preferable to make it in two pieces matched together, as shown in fig. 8, and that all of the foregoing description may be understood as applied to such construction. My experiments thus far with my invention have all been on this pieced form of the bar E because of the advantages thereon attending.

I claim—

1. The adjustable double series of sheaves M N, carried on the doors and adapted to work, as represented, on the single way E, when the lower series of sheaves, N, is adjustable or movable up and down to fit tightly to the way, substantially as herein specified.

2. The elastic stops  $G^1$   $G^2$ , or either of them, arranged as specified, so as to arrest the motion of the door gently, as set forth.

3. The adjusting-screws  $g^1$   $g^2$ , in combination with the step-plates R, struts  $G^1$   $G^2$ , and way or rail E, which supports the sliding doors, as specified.

4. The bar or way E, made in two pieces halved together when connected to the central bolt C, and adapted to be adjusted up and down at each end, so as to carry the sheaves which support the double door, and to allow the sheaves and the bar E itself to be easily introduced and removed, in the manner and for the purposes herein set forth.

In testimony whereof I have hereunto set my name in presence of two subscribing witnesses.

JOHN MORE.

Witnesses:

WM. C. DEY,  
C. C. LIVINGS.