

(19) World Intellectual Property
Organization
International Bureau



(43) International Publication Date
19 February 2004 (19.02.2004)

PCT

(10) International Publication Number
WO 2004/014543 A1

- (51) International Patent Classification⁷: **B01J 19/00**, B01L 3/00
- (21) International Application Number: PCT/NL2002/000538
- (22) International Filing Date: 9 August 2002 (09.08.2002)
- (25) Filing Language: English
- (26) Publication Language: English
- (71) Applicant (for all designated States except US): **AVANTIUM INTERNATIONAL B.V.** [NL/NL]; 29,Zekeringsstraat, NL-1014 BV Amsterdam (NL).
- (71) Applicant and
- (72) Inventor (for US only): **NAGY, Anton, John** [US/NL]; Lijnbaansgracht 165 II, NL-1016 VX Amsterdam (NL).
- (74) Agent: **BROOKHUIS, H.J.A.**; Exter Polak & Charlouis B.V., P.O. Box 3241, NL-2280 GE Rijswijk (NL).
- (81) Designated States (national): AE, AG, AL, AM, AT, AU, AZ, BA, BB, BG, BR, BY, BZ, CA, CH, CN, CO, CR, CU, CZ, DE, DK, DM, DZ, EC, EE, ES, FI, GB, GD, GE, GH, GM, HR, HU, ID, IL, IN, IS, JP, KE, KG, KP, KR, KZ, LC, LK, LR, LS, LT, LU, LV, MA, MD, MG, MK, MN, MW, MX, MZ, NO, NZ, OM, PH, PL, PT, RO, RU, SD, SE, SG, SI, SK, SL, TJ, TM, TN, TR, TT, TZ, UA, UG, US, UZ, VC, VN, YU, ZA, ZM, ZW.
- (84) Designated States (regional): ARIPO patent (GH, GM, KE, LS, MW, MZ, SD, SL, SZ, TZ, UG, ZM, ZW), Eurasian patent (AM, AZ, BY, KG, KZ, MD, RU, TJ, TM), European patent (AT, BE, BG, CH, CY, CZ, DE, DK, EE, ES, FI, FR, GB, GR, IE, IT, LU, MC, NL, PT, SE, SK, TR), OAPI patent (BF, BJ, CF, CG, CI, CM, GA, GN, GQ, GW, ML, MR, NE, SN, TD, TG).
- Published:
— with international search report

[Continued on next page]

(54) Title: INTRODUCING REAGENTS INTO A LABORATORY REACTOR

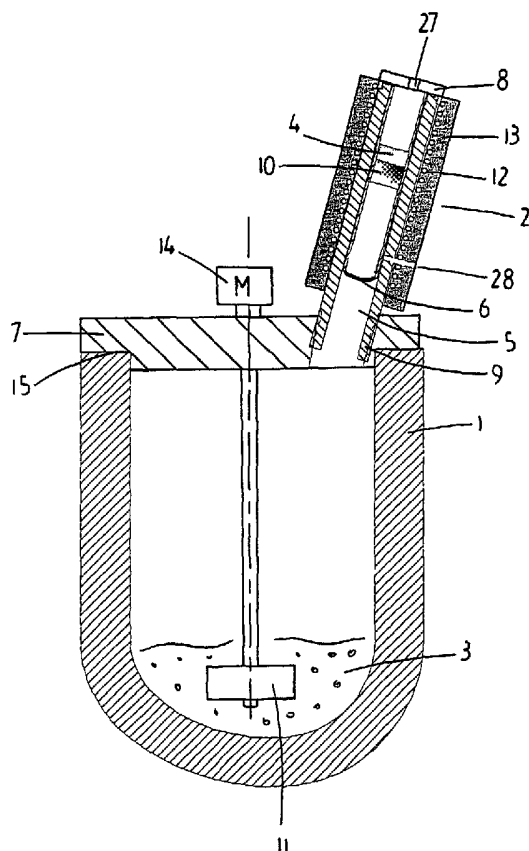

(57) Abstract: A method and device for conducting chemical experiments, wherein a second reactant is added to a first reactant. The method comprising the following steps: - introducing a first reactant in a reactor vessel and isolating it from the atmosphere, - introducing a predetermined quantity of a second reactant in a batch storage vessel, and isolating it from the atmosphere, - wherein the reactor vessel and the batch storage vessel are interconnected via a transfer passage provided with a closure that can be opened on command, so that the second reactant can be introduced into the reactor vessel, - wherein the closure is of a type that opens when a predetermined pressure difference is applied between the batch storage vessel and the reactor vessel, and - creating the predetermined pressure difference between the reactor vessel and the batch storage vessel, so that the closure in the transfer passage that interconnects the batch storage vessel and the batch reactor vessel opens and the second reactant is introduced into the reactor vessel.

WO 2004/014543 A1



For two-letter codes and other abbreviations, refer to the "Guidance Notes on Codes and Abbreviations" appearing at the beginning of each regular issue of the PCT Gazette.

INTRODUCING REAGENTS INTO A LABORATORY REACTOR

The invention relates to a method and a device for conducting a laboratory chemical experiment involving multiple chemical reactants in a reactor vessel, in particular a batch reactor vessel, which is isolated from the atmosphere.

5

In laboratory chemical experiments, at least two chemical substances or mixtures (so-called reactants) are brought together in order to react under predetermined process conditions. Often, these desired process conditions differ significantly from the conditions in the laboratory itself, as they may include for example an elevated process temperature, an elevated process pressure or the absence of oxygen and/or moisture. Moreover, these desired process conditions often have to be controlled accurately.

15

In current practice, the substances or mixtures participating in the reaction are first brought together in a batch reactor vessel. Then, the batch reactor vessel is closed and thus isolated from the atmosphere and brought to the desired process conditions. A significant disadvantage of this method is that the actual reaction is likely to start before the desired process conditions are reached. This makes interpretation of the results of the experiments difficult, which is especially adverse in combinatorial research experiments where multiple experiments are conducted (in parallel) and the results of the experiments compared to each other.

25

Therefore, it is desirable to create desired process conditions, possibly including an elevated process pressure in the reactor vessel before introducing the second reactant into the reactor vessel.

30

It is the aim of the present invention to overcome one or more of the drawbacks mentioned above.

The present invention provides a method for conducting chemical experiments, wherein a second reactant is added to a first reactant, the method comprising the following steps:

- introducing a first reactant in a reactor vessel and isolating it from the atmosphere,
- introducing a predetermined quantity of a second reactant in a batch storage vessel, and isolating it from the atmosphere,
- wherein the reactor vessel and the batch storage vessel are interconnected via a transfer passage provided with a closure that can be opened on command, so that the second reactant can be introduced into the reactor vessel,
- wherein the closure is of a type that opens when a predetermined pressure difference is applied between the batch storage vessel and the reactor vessel, and
- creating the predetermined pressure difference between the reactor vessel and the batch storage vessel, so that the closure in the transfer passage that interconnects the batch storage vessel and the batch reactor vessel opens and the second reactant is introduced into the reactor vessel.

The present invention also provides a method for opening a closure in a transfer passage between a reactor vessel, in particular a batch reactor vessel, and a batch storage vessel, comprising the following steps:

- applying a first pressure in the reactor vessel and a second pressure in the batch storage vessel, which first pressure is essentially equal to the second pressure,
- modifying at least one of the first and second pressure so that a pressure difference is created between the reactor vessel and the batch storage vessel that is large enough to open the closure in the transfer passage between the reactor vessel and the batch storage vessel.

Moreover, the present invention provides a device for conducting a laboratory chemical experiment involving multiple chemical reactants in a reactor vessel, which is isolated from the atmosphere. The device according to the invention comprises a batch storage vessel, which can also be isolated from the atmosphere, for storing a predetermined quantity of a second reactant, which quantity is adapted to the amount of second reactant that is required for an experiment. In the device according to the invention, the reactor vessel and the batch storage vessel are interconnected via a transfer passage provided with a closure that can be opened on command, so that the second reactant can be introduced into the reactor vessel. The device according to the invention is characterised in that the closure is of a type that opens when a predetermined pressure difference is applied between the batch storage vessel and the reactor vessel.

When conducting a laboratory chemical experiment using the device according to the invention, a first reactant (which can be a mixture) is introduced in the reactor vessel and the contents of the reactor vessel is then isolated from the outside atmosphere. A predetermined quantity of a second reactant is introduced in the batch storage vessel and the content of the batch storage vessel is isolated from the outside atmosphere as well. The quantity of the second reactant introduced in the reactor vessel is adapted to the amount of second reactant that the experiment to be conducted requires.

Advantageously, prior to adding the second reactant to the first reactant in the reactor vessel, the predetermined process conditions are substantially established in both the reactor vessel and the batch storage vessel, so that the reaction starts under optimal process conditions as the second reactant is introduced into the reactor vessel.

The advantage of this is that when the second reactant comes into contact with the first reactant, the predetermined process conditions are already present, so the start of the reaction takes place under optimal process conditions. This improves the quality of the measured data during the experiment, in particular during the first stage of the reaction, significantly.

More advantageously, the pressure in the batch storage vessel is somewhat higher than the pressure in the reactor vessel prior to opening the closure. This facilitates the introduction of the second reactant into the reactor vessel, even when a high absolute pressure is present in the reactor vessel.

In the device according to the invention, the reactor vessel and the batch storage vessel are interconnected by a transfer passage provided with a closure. The opening of this closure establishes an open connection between the batch storage vessel and the reactor vessel via the transfer passage, allowing the second reactant to be displaced from the batch storage vessel via the transfer passage into the reactor vessel, adding it to the first reactant. Still, the interconnected chambers of the reactor vessel and the batch storage vessel and the transfer passage remain isolated from the atmosphere.

The closure in the transfer passage is of a pressure responsive type that opens when a predetermined pressure difference is applied between the batch storage vessel and the reactor vessel. Such a closure could be e.g. a pressure responsive valve, a plug seated in a corresponding seat or, most preferably, a frangible closure, preferably a bursting or rupture disc.

In order to open such a closure on command, a first pressure is applied in the reactor vessel and/or a second pressure is applied in the batch storage vessel. A pressure difference is created between the reactor vessel and the batch storage vessel, such that the predetermined opening pressure difference of the

closure is reached or exceeded, such that the closure opens and the second reactant is introduced into the reactor vessel.

5 Preferably, the first pressure and the second pressure are first essentially equal, so that no or just small resulting forces are exerted on the closure. This way, the construction of the closure can be kept light and of small dimensions. Then, at least one of the pressures is changed in order to create the pressure difference that is required for opening the closure.

10

Preferably, the first pressure and the second pressure are essentially equal to the desired process pressure.

15 Preferably, the first pressure and the second pressure are created by introducing a fluid such as a gas, a vapour or a liquid into the reactor vessel and batch storage vessel respectively.

20 Sometimes, the second reactant needs to be pre-treated before introduction into the reactor vessel. For those cases, the fluid that is used to apply the second pressure, is preferably used as well for pre-treating the second reactant before the second reactant is introduced into the reactor vessel.

25 Preferably, the fluid that provides the second pressure in the batch storage vessel, is used as well for bringing the second reactant to essentially the desired process conditions, for example with respect to pressure, temperature and/or atmosphere.

30 Preferably, the fluid that provides the first pressure in the reactor vessel, is used as well for bringing the first reactant to essentially the desired process conditions, for example with respect to pressure, temperature and/or atmosphere.

35 The method according to the invention can be applied to a single laboratory reactor, or multiple reactors, e.g. to an array of

laboratory reactors, such as found in high throughput experimentation.

Preferably, the device according to the invention comprises
5 pressure means for applying a pressure difference between the batch storage vessel and the reactor vessel in order to open the closure.

Preferably, the smallest predetermined pressure difference
10 between the batch storage vessel and the reactor vessel at which the closure in the transfer passage is adapted to open, is 100mbar to 15 bar, preferably 5 to 8 bar. Ultimately, the pressure difference required to introduce the second reactant is a function of the absolute pressure in both the reactor vessel
15 and the storage vessel. At higher pressures a particular pressure difference will result in a lower convective gas flow due to compression. It is, therefore, necessary to use higher pressure drops to introduce the second reactant when working at higher absolute pressures.

20

The pressure difference at which the closure has to open can be optimised for each specific experiment, for example by using bursting discs of different materials and/or structure, such as different thickness. This is advantageous especially wherein the
25 second reactant is a solid e.g. a powder. In those cases, the efficiency of the transport of the second reactant from the batch storage vessel to the reactor vessel depends on the flow rate of the fluid from the batch storage vessel to the reactor vessel. This flow rate, in turn, depends on the pressure
30 difference between these vessels.

Preferably, the pressure means comprise first flow means that are adapted to apply a first pressure in the reactor vessel, and second flow means that are adapted to apply a second pressure in
35 the batch storage vessel. These first flow means and/or the second flow means are preferably adapted to use a fluid, such as

a gas, a vapour or a liquid, to establish the first pressure and/or the second pressure respectively.

5 Preferably, the fluid introduced by the second flow means is adapted to pre-treat the second reactant, before the second reactant is introduced into the reactor vessel.

10 Preferably, the second flow means are adapted to bring the second reactant to essentially the desired process conditions, for example with respect to pressure, temperature and/or atmosphere.

15 Preferably, the first flow means are adapted to bring the first reactant to essentially the desired process conditions, for example with respect to pressure, temperature and/or atmosphere.

20 For the cases in which the second reactant is solid or in a powdery form, the batch storage vessel preferably comprises a support to hold the solid or powdery second reactant at a distance from the closure while the closure is shut. This support can for example be made of quartz wool.

25 Possibly, multiple batch storage vessels are associated with a single reactor vessel. Moreover, it is envisaged that multiple devices according to the invention are used as an array of devices to conduct combinatorial research experiments. In this case, a parallel arrangement of reactor vessels, each associated with at least one batch storage vessel, is advantageously used to screen an large number of systems in a short time, for
30 example in catalyst screening or rapid process optimisation studies.

35 Advantageously, the reactor vessel comprises agitation means such as a stirrer or static mixer.

Advantageously, the reactor vessel and/or the batch storage vessel are thermally insulated.

Advantageously, the reactor vessel comprises heating and/or cooling means.

5 Advantageously, the batch storage vessel comprises heating and/or cooling means.

Advantageously, the batch storage vessel is detachably secured to the reactor vessel, for example by means of a screw thread
10 connection. For example, the reactor vessel has a lid, and the batch storage vessel is screwed onto that lid.

Exemplary embodiments of the device according to the invention will be described in detail below, with reference to the
15 drawing.

The drawing shows in:

- Fig. 1. an overview of a first device according to the invention,
- 20 Fig. 2. the batch storage vessel with integrated transfer passage and closure in more detail,
- Fig. 3. diagrammatical representation of a second device according to the invention comprising a first and a second gas flow means,
- 25 Fig. 4. diagrammatical representation of a third device according to the invention comprising a third gas flow means.

Fig. 1 shows an overview of a device according to the invention.
30 The device comprises a batch reactor vessel 1 having a reaction chamber for receiving a first reactant 3 and a batch storage vessel 2 having a storage chamber for receiving a second reactant 4. As explained the first and second reactant 3, 4 can be composed of one or more components.

35

The reactor vessel 1 allows for isolation of the reaction chamber from the atmosphere and the storage vessel 2 allows for isolation of the storage chamber from the atmosphere.

5 The batch reactor vessel 1 and the batch storage vessel 2 are interconnected by a connector member having a transfer passage 5. A closure 6 is provided for keeping said passage 5 closed as will be explained below.

10 In the embodiment shown in Fig. 1, the closure 6 is a frangible seal 6, in this example a domed bursting disc, and the connector member including the transfer passage 5 and the frangible seal 6 are integrated in the batch storage vessel 2.

15 The frangible seal 6 could be e.g. a metal member, a graphite member, a glass member, a plastic member or a quartz member. Also, other materials that are suitable for the specific process conditions can be used. In this embodiment a dome metal member 6 is welded on the lower end of a tubular body forming the storage
20 chamber of the batch storage vessel 2.

Batch reactor vessel 1 can be isolated from the atmosphere by closing lid 7, which is provided with sealing means such as an O-ring. Batch storage vessel 2 is releasably mounted on the lid
25 7, in this example by means of screw thread 9, that provides an airtight closure. Batch storage vessel 2 has an internal storage chamber that is isolated from the atmosphere by means of lid 8.

In an advantageous application of the embodiment shown in Fig.1
30 and 2, the second reactant is a catalyst 4, e.g. in a powdery form. In the batch storage vessel 2, the catalyst 4 is held at a distance from the frangible seal 6 by support 10, which is made of quartz wool here. Fig. 2 shows the batch storage vessel in more detail.

35

Fig. 3 shows diagrammatically a general layout of the device according to the invention, comprising pressure means for applying a pressure difference over the frangible seal 6.

5 The pressure means comprise first flow means 30 and second flow means 20. The first flow means 30 here comprise accordingly a reservoir 31 for a fluid, a flow controller 35 (such as a mass-flow controller, a volumetric flow controller or any kind of pump), a supply line 32, a discharge line 33, a pressure control
10 valve 34, an inlet 37 and an optional outlet 38. The second flow means 20 here comprise a reservoir 21 for a fluid, a flow controller 25 (such as a mass-flow controller, a volumetric flow controller or any kind of pump), a supply line 22, a discharge line 23, a pressure control valve 24, an inlet 27 and an outlet
15 28.

When conducting a laboratory chemical experiment using the method and the device according to the invention, a first reactant 3 is introduced in the batch reactor vessel 1 and the
20 contents of the batch reactor vessel is isolated from the outside atmosphere by closing the lid 7 of the batch reactor vessel 1. The lid 7 of the batch reactor vessel 1 is equipped with suitable sealing means 15 to provide a gas-tight closure.

25 Then, a predetermined quantity of catalyst 4 is introduced in the batch storage vessel 2 and the content of the batch storage vessel 2 is isolated from the outside atmosphere as well. The quantity of the catalyst 4 introduced in the batch storage vessel 2 is adapted to the amount of catalyst that the
30 experiment to be conducted requires.

While the frangible seal 6 is still closed, the batch reactor vessel 1 is pressurised to the first pressure using the first flow means 30 introducing a pressurised fluid into the vessel 1.
35 Additionally, the predetermined process conditions are substantially established in the batch reactor vessel 1. This is preferably also achieved by means of the fluid supplied by the

first flow means 30, e.g. by introducing said fluid at a suitable pressure and temperature. Said fluid, such as a gas, a vapour or a liquid, flows from the reservoir 31 through supply line 32 to batch reactor vessel 1, and is optionally discharged
5 again via discharge line 33. Thus, batch reactor vessel 1 is pressurised and for example heated, cooled, and/or purged.

Simultaneously, the batch storage vessel 2 is pressurised to the second pressure and additionally conditioned accordingly by a
10 fluid supplied by the second flow means 20. In addition, the catalyst 4 may also be pre-treated by the fluid supplied by the second flow means 20. Moreover, in some cases the first reactant will be pre-treated by the first flow means 30. For example, if the second reactant 4 is a catalyst, reduction is often a
15 desired pre-treatment. In the shown embodiment, this pre-treatment can for instance be carried out by an H₂-gas flow established by the second flow means 20 through the batch storage vessel 2.

20 Preferably, the first pressure is substantially equal to the second pressure, e.g. during the pre-treatment of the first and/or second reactant. This way, no or just small resulting forces are exerted during said phase on the closure 6, so that the construction of the closure 6 can be kept light and of small
25 dimensions.

After pressurising the batch reactor vessel 1 to the first pressure and the batch storage reactor vessel 2 to the second pressure and, if any, conditioning and pre-treating of the
30 contents of either of the vessels, a predetermined pressure difference (for example 5 bar) between the batch storage vessel 2 and the batch reactor vessel 1 is created. Preferably, this relatively small pressure difference is created by changing the settings of the pressure control valves 24, 34. Preferably, the
35 pressure in the batch storage vessel 2, controlled by pressure control valve 24 is higher than the pressure in the batch

reactor vessel 2, which is controlled by pressure control valve 34.

5 Due to the pressure difference, the frangible seal 6 will break or rupture. By the combined influence of pressure and gravity the catalyst 4 is introduced in the batch reactor vessel 1.

10 In a different embodiment that is not shown in the drawing, the closure 6 is a valve, e.g. a valve that is normally closed under spring action. When a pressure difference between the batch reactor vessel 1 and the batch storage vessel 2 is created that is sufficiently large, the valve will open against the spring action. This embodiment is suitable in those cases where
15 contamination of the closure by the second reactant will not hinder the operation of the moving parts of the closure, such as when the second reactant is a gas, a vapour or a liquid.

In another exemplary embodiment that is not shown in the drawing the closure is a plug, seated in a corresponding seat. The plug
20 can be held in its seat for example by friction. The plug is displaced from its seat by applying a pressure difference between the batch storage vessel and the batch reactor vessel. In that case, the pressure difference between the batch storage vessel and the batch reactor vessel has to be large enough to
25 overcome the retaining force between the plug and its seat, for example the friction.

As is shown in Fig. 1 and 2, the batch reactor vessel 1 can be equipped with a stirrer 11 driven by a motor 14, and the batch
30 storage vessel 2 can be provided with heating means 12 and thermal insulation 13.

Fig. 4 shows a different possible embodiment of the pressure means.

35

Initially, a pre-treatment gas flows from a reservoir 41 via a flow controller 45 to the supply lines 42 and 43. Valve 46 is

open, so the batch reactor vessel 1 acquires essentially the same pressure as the supply line 42. Meanwhile, gas flows via supply line 43, capillary 48 (optional) through batch storage vessel 2, where the catalyst 4 is pre-treated, for example
5 reduced. Pressure control valve 47 controls the pressure in the system.

When the pre-treatment of the catalyst 4 has been completed, valve 49 is closed. The system is then pressurised to
10 essentially the predetermined process pressure. Then, valve 46 is closed, and the pressure in the batch storage vessel is increased to break the frangible seal 6, in order to introduce the catalyst 4 into the batch reactor vessel.

15 In a different embodiment that is not shown in the drawing, a batch reactor vessel may be associated with multiple batch storage vessels.

In a different embodiment that is not shown in the drawing, an
20 array of devices according to the invention may be used for conducting combinatorial research experiments.

C L A I M S

1. Method for conducting chemical experiments, wherein a second reactant is added to a first reactant, the method comprising the following steps:
- 5 - introducing a first reactant in a reactor vessel and isolating it from the atmosphere,
 - introducing a predetermined quantity of a second reactant in a batch storage vessel, and isolating it from the atmosphere,
 - 10 - wherein the reactor vessel and the batch storage vessel are interconnected via a transfer passage provided with a closure that can be opened on command, so that the second reactant can be introduced into the reactor vessel,
 - 15 - wherein the closure is of a type that opens when a predetermined pressure difference is applied between the batch storage vessel and the reactor vessel, and
 - creating the predetermined pressure difference between the reactor vessel and the batch storage vessel, so that the closure in the transfer passage that interconnects the batch storage vessel and the batch reactor vessel opens and the second reactant is introduced into the reactor vessel.
 - 20
 - 25
2. Method according to claim 1, in which - prior to opening the closure - a first pressure is created in the reactor vessel and a second pressure is created in the batch storage vessel, and in which the first and second pressure are first brought to an essentially equal value, after which at least one of the first and second pressure is changed in order to create the predetermined pressure difference that is required for opening the closure.
- 30
3. Method according to claim 1 or 2, in which the first pressure and the second pressure are created by introduction of a pressurised fluid into the reactor vessel and batch storage vessel respectively, such as a gas, a vapour or a liquid.
- 35

4. Method according to any of the preceding claims, in which the first pressure and the second pressure at the time of opening the closure are essentially equal to a desired process
5 pressure for conducting the experiment.

5. Method according to claim 3, in which the fluid that is used to create the second pressure, is used as well for pre-treating the second reactant before the second reactant is
10 introduced into the reactor vessel.

6. Method according to claim 3 or 5, in which the fluid that is used to create the second pressure, is used as well for bringing the second reactant to essentially the desired process
15 conditions, for example with respect to pressure, temperature and/or atmosphere.

7. Method according to any of the claims 3, 5, 6, in which the fluid that is used to create the first pressure, is used as well for bringing the first reactant to essentially the desired
20 process conditions, for example with respect to pressure, temperature and/or atmosphere.

8. Method for opening a closure in a transfer passage
25 between a reactor vessel, in particular a batch reactor vessel, and a batch storage vessel, comprising the following steps:
- applying a first pressure in the reactor vessel and a second pressure in the batch storage vessel, which first pressure is essentially equal to the second pressure,
30 - modifying at least one of the pressures so that a pressure difference is created between the reactor vessel and the batch storage vessel that is large enough to open the closure in the transfer passage between the reactor vessel and the batch storage vessel.

35

9. Method, according to any of the preceding claims, applied to an array of devices according to claims 10-36.

10. Device for conducting laboratory chemical experiments,
5 involving multiple chemical reactants in a reactor vessel, in particular a batch reactor vessel, which has an internal reaction chamber which can be isolated from the atmosphere, which device comprises a batch storage vessel, which has an internal storage chamber, which can be isolated from the
10 atmosphere, for storing a predetermined quantity of a second reactant,
and in which the reactor vessel and the batch storage vessel are interconnected via a transfer passage provided with a closure that can be opened on command, so that the second reactant can
15 be introduced into the reactor vessel,
characterised in that,
the closure is of a type that opens when a predetermined pressure difference is applied between the batch storage vessel and the reactor vessel.

20

11. Device according to claim 10, in which the device comprises pressure means for applying a pressure difference between the batch storage vessel and the reactor vessel in order to open the closure.

25

12. Device according to claim 10 or 11, in which the smallest pressure difference between the batch storage vessel and the batch reactor vessel at which the closure is adapted to open, is 100mbar to 15 bar, preferably 5 to 8 bar.

30

13. Device according to any of the claims 10-12, in which the pressure means comprise first flow means that are adapted to apply a first pressure in the reactor vessel, and second flow means that are adapted to apply a second pressure in the batch
35 storage vessel.

14. Device according to claim 13, in which the first flow means and/or the second flow means are adapted to introduce a pressurised fluid into the reactor vessel and batch storage vessel respectively, such as a gas, a vapour or a liquid, to
5 create the first pressure and/or the second pressure respectively.

15. Device according to claim 13 or 14, in which the second flow means are adapted to introduce a fluid into the batch
10 storage vessel which fluid effects a pre-treatment of the second reactant, before the second reactant is introduced into the reactor vessel.

16. Device according to any of the claims 13-15, in which
15 the fluid introduced by the second flow means is conditioned to bring the second reactant to essentially the desired process conditions, for example with respect to pressure, temperature and/or atmosphere.

20 17. Device according to any of the claims 13-16, in which the first flow means are adapted to bring the first reactant to essentially the desired process conditions, for example with respect to pressure, temperature and/or atmosphere.

25 18. Device according to any of the claims 10-17, in which the closure is a valve.

19. Device according to any of the claims 10-17, in which
the closure is a frangible seal.

30

20. Device according to claim 19, in which the frangible seal is a bursting disc, preferably of inert material.

21. Device according to claim 20, in which the material of
35 the bursting disc is graphite, quartz, glass, metal or plastic.

22. Device according to any of the claims 10-17, in which

the closure is a plug, seated in a corresponding seat and which plug is displaceable from said seat due to a pressure difference between the batch storage vessel and the reactor vessel.

5 23. Device according to any of the claims 10-22, in which the batch storage vessel comprises a support to hold a solid or powdery second reactant at a distance from the closure while the closure is shut.

10 24. Device according to claim 23, in which the material of the support is quartz wool.

25. Device according to any of the claims 10-24, in which the reactor vessel and/or batch storage comprises agitation
15 means such as e.g. a stirrer or a static mixer.

26. Device according to any of the claims 10-25, in which the reactor vessel and/or the batch storage vessel are thermally insulated.

20

27. Device according to any of the claims 10-26, in which the reactor vessel and/or batch storage vessel comprises heating and/or cooling means.

25 28. Device according to any of the claims 10-27, in which the reactor vessel has a lid and that the batch storage vessel is detachably secured to the lid of the reactor vessel, for example by means of a screw thread connection.

30 29. Device according to any of the claims 10-28, in which multiple batch storage vessels are associated with a reactor vessel.

35 30. Batch storage vessel according to any of the claims 10-29.

31. Batch storage vessel with integrated transfer passage, according to any of the claims 10-29.

32. Batch storage vessel with integrated transfer passage and closure, according to any of the claims 10-29.

5 33. Reactor vessel, in particular a batch reactor vessel, suitable for use together with a batch storage vessel according to any of the claims 10-32.

10 34. Reactor vessel, in particular a batch reactor vessel, with integrated transfer passage suitable for use together with a batch storage vessel according to of the claims 10-32.

15 35. Reactor vessel with integrated transfer passage and closure suitable for use together with a batch storage vessel according to any of the claims 10-32.

36. Array of devices according to any of the claims 10-35.

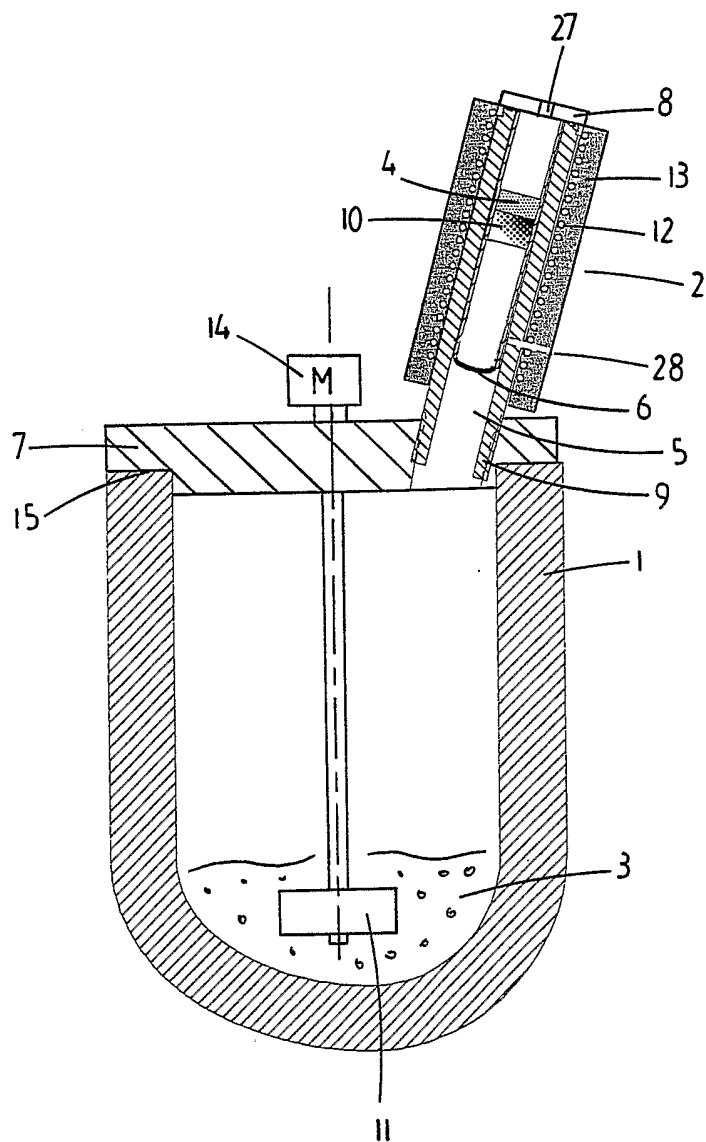

Fig. 1

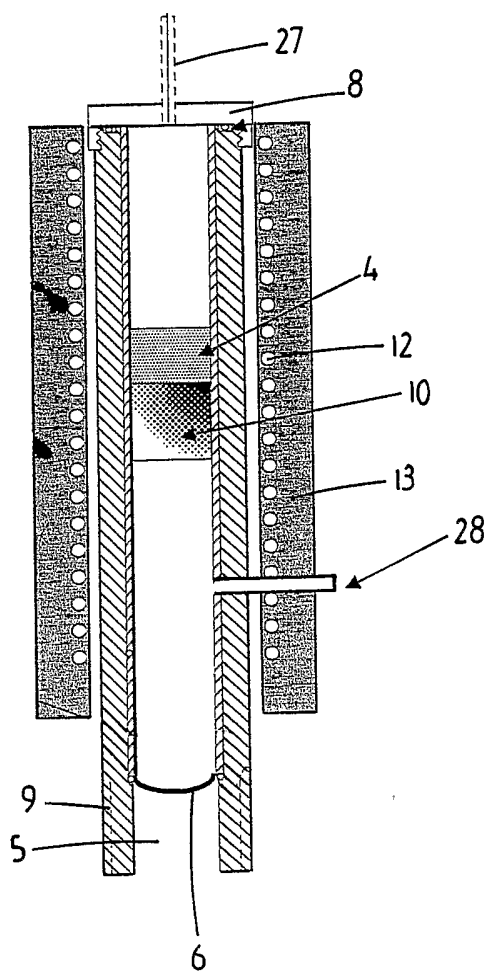

Fig. 2

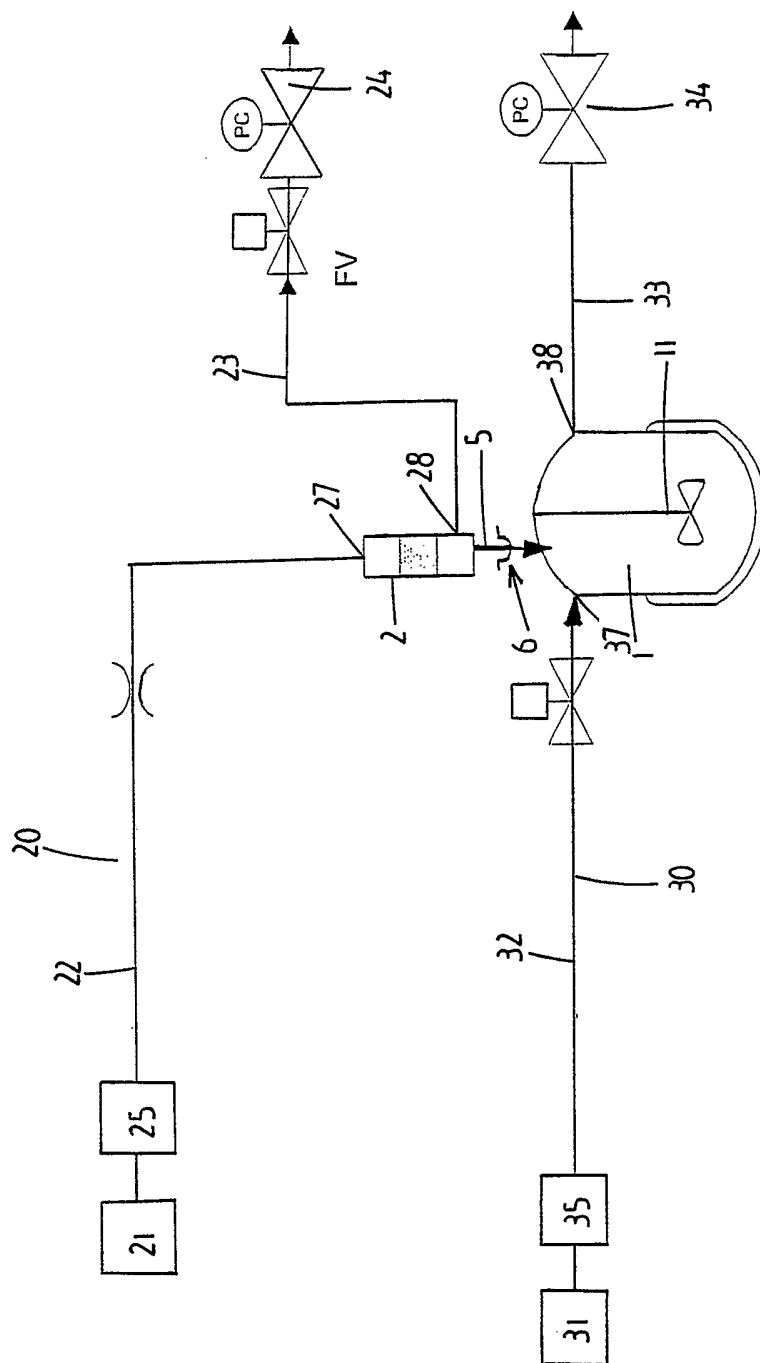

Fig. 3

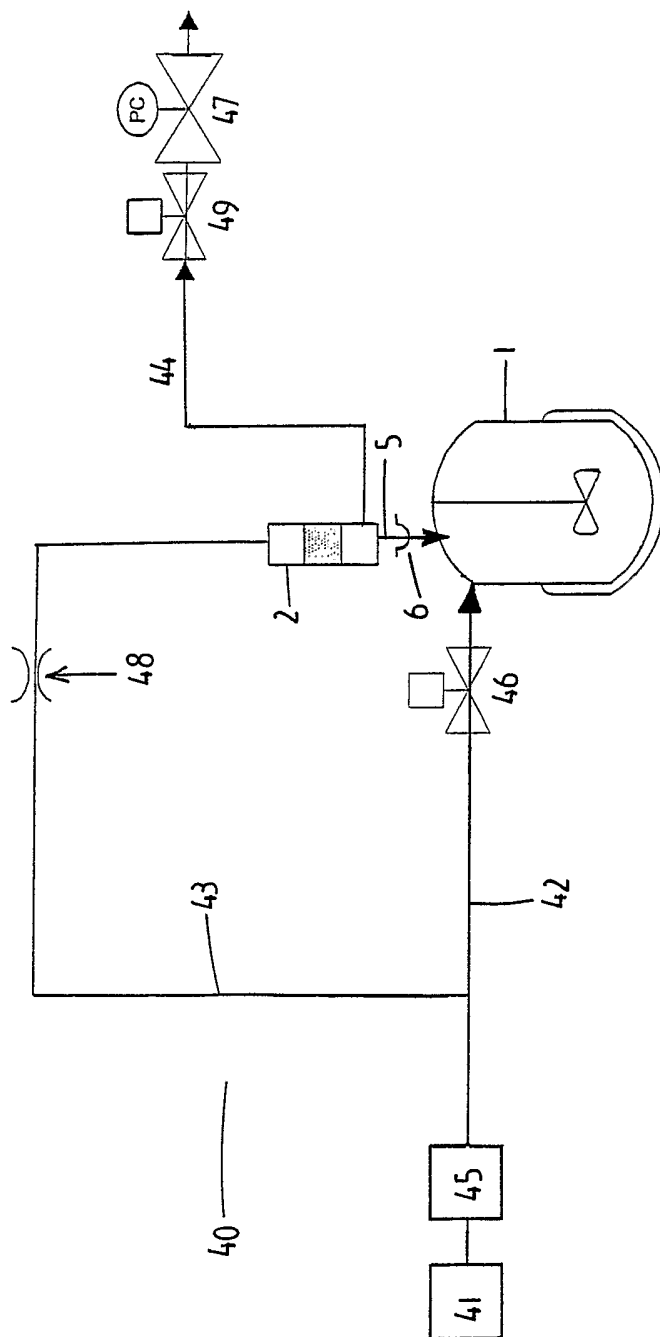

Fig. 4

INTERNATIONAL SEARCH REPORT

International Application No
PCT/NL 02/00538

A. CLASSIFICATION OF SUBJECT MATTER
IPC 7 B01J19/00 B01L3/00

According to International Patent Classification (IPC) or to both national classification and IPC

B. FIELDS SEARCHED

Minimum documentation searched (classification system followed by classification symbols)
IPC 7 B01J B01L

Documentation searched other than minimum documentation to the extent that such documents are included in the fields searched

Electronic data base consulted during the international search (name of data base and, where practical, search terms used)

EPO-Internal, WPI Data, PAJ

C. DOCUMENTS CONSIDERED TO BE RELEVANT

Category °	Citation of document, with indication, where appropriate, of the relevant passages	Relevant to claim No.
X	WO 02 43854 A (HTE AG ;SCHUNK STEPHAN ANDREAS (DE)) 6 June 2002 (2002-06-06) page 9, line 14 -page 11, line 16 -----	1-36
X	WO 98 10866 A (ALPHAHELIX AB ;MALMQVIST MATS (SE)) 19 March 1998 (1998-03-19) page 6, line 29 -page 7, line 25 page 9, line 12 - line 24; figures 1,2 -----	10, 19, 22, 26-36

Further documents are listed in the continuation of box C.

Patent family members are listed in annex.

° Special categories of cited documents :

- *A* document defining the general state of the art which is not considered to be of particular relevance
- *E* earlier document but published on or after the international filing date
- *L* document which may throw doubts on priority claim(s) or which is cited to establish the publication date of another citation or other special reason (as specified)
- *O* document referring to an oral disclosure, use, exhibition or other means
- *P* document published prior to the international filing date but later than the priority date claimed

- *T* later document published after the international filing date or priority date and not in conflict with the application but cited to understand the principle or theory underlying the invention
- *X* document of particular relevance; the claimed invention cannot be considered novel or cannot be considered to involve an inventive step when the document is taken alone
- *Y* document of particular relevance; the claimed invention cannot be considered to involve an inventive step when the document is combined with one or more other such documents, such combination being obvious to a person skilled in the art.
- *&* document member of the same patent family

Date of the actual completion of the international search

9 April 2003

Date of mailing of the international search report

17/04/2003

Name and mailing address of the ISA

European Patent Office, P.B. 5618 Patentlaan 2
NL - 2280 HV Rijswijk
Tel. (+31-70) 340-2040, Tx. 31 651 epo nl,
Fax: (+31-70) 340-3016

Authorized officer

Veefkind, V

INTERNATIONAL SEARCH REPORT

 Internat'l Application No
 PCT/NL 02/00538

Patent document cited in search report		Publication date	Patent family member(s)	Publication date
WO 0243854	A	06-06-2002	DE 10059633 A1	20-06-2002
			AU 1707902 A	11-06-2002
			WO 0243854 A2	06-06-2002
			US 2002089868 A1	11-07-2002

WO 9810866	A	19-03-1998	AT 220951 T	15-08-2002
			AU 725668 B2	19-10-2000
			AU 4406897 A	02-04-1998
			CN 1230904 A ,B	06-10-1999
			DE 69714269 D1	29-08-2002
			DE 69714269 T2	27-03-2003
			DK 925113 T3	18-11-2002
			EP 0925113 A1	30-06-1999
			ES 2181028 T3	16-02-2003
			JP 2001508644 T	03-07-2001
			PL 332047 A1	16-08-1999
			WO 9810866 A1	19-03-1998
			US 6432694 B1	13-08-2002
