

No. 711,432.

Patented Oct. 14, 1902.

W. A. LORENZ & W. H. HONISS.

JAR SEALING APPARATUS.

(Application filed Jan. 5, 1901.)

(No Model.)

2 Sheets—Sheet 1.

Fig. 1

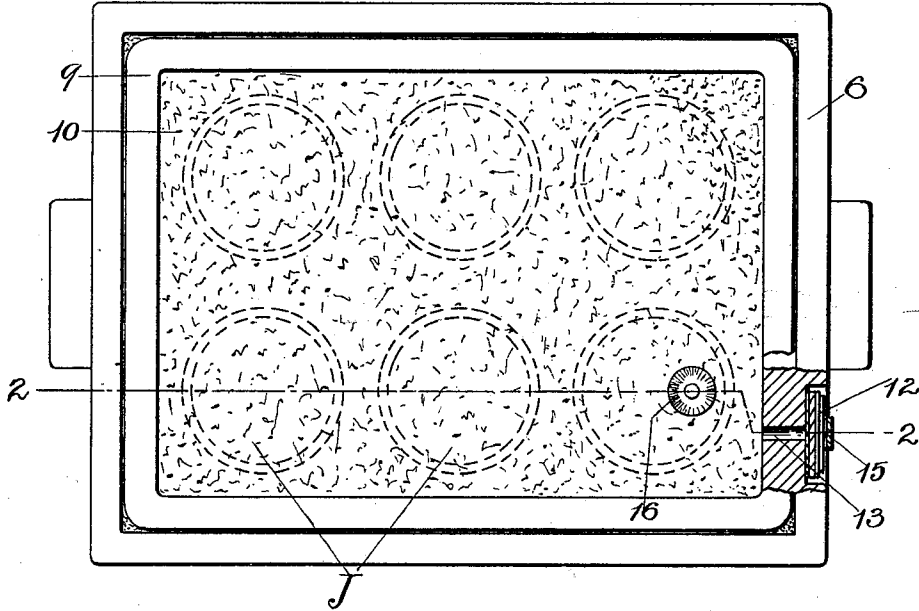

Fig. 2

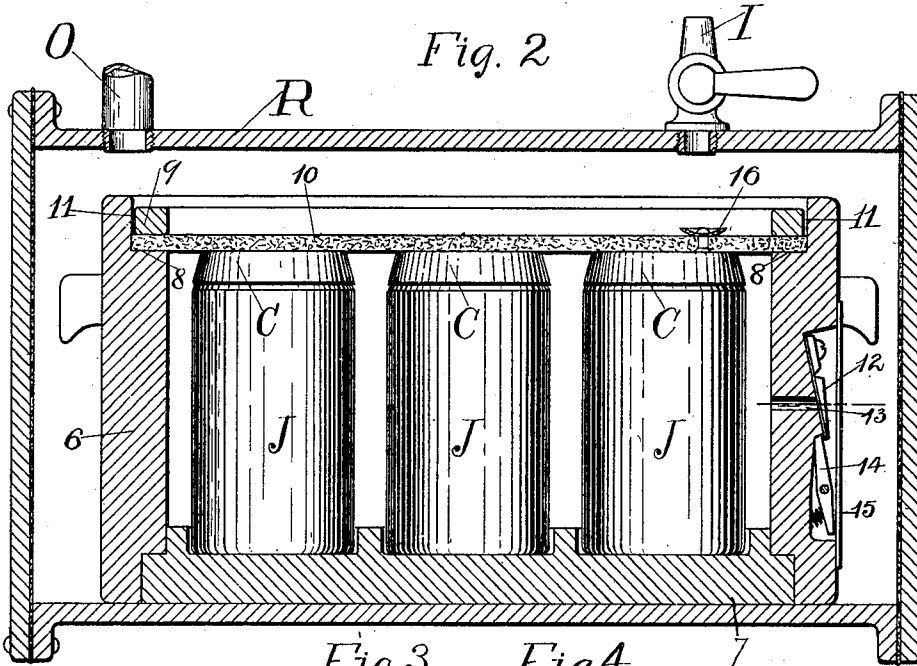
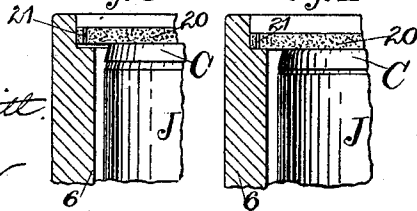

Fig. 3

Fig. 4



Witnesses:
Joseph Meritt.
H. Mallner

Inventors:
William A. Lorenz
W. H. Honiss.

No. 711,432.

Patented Oct. 14, 1902.

W. A. LORENZ & W. H. HONISS.
JAR SEALING APPARATUS.

(Application filed Jan. 5, 1901.)

(No Model.)

2 Sheets—Sheet 2.

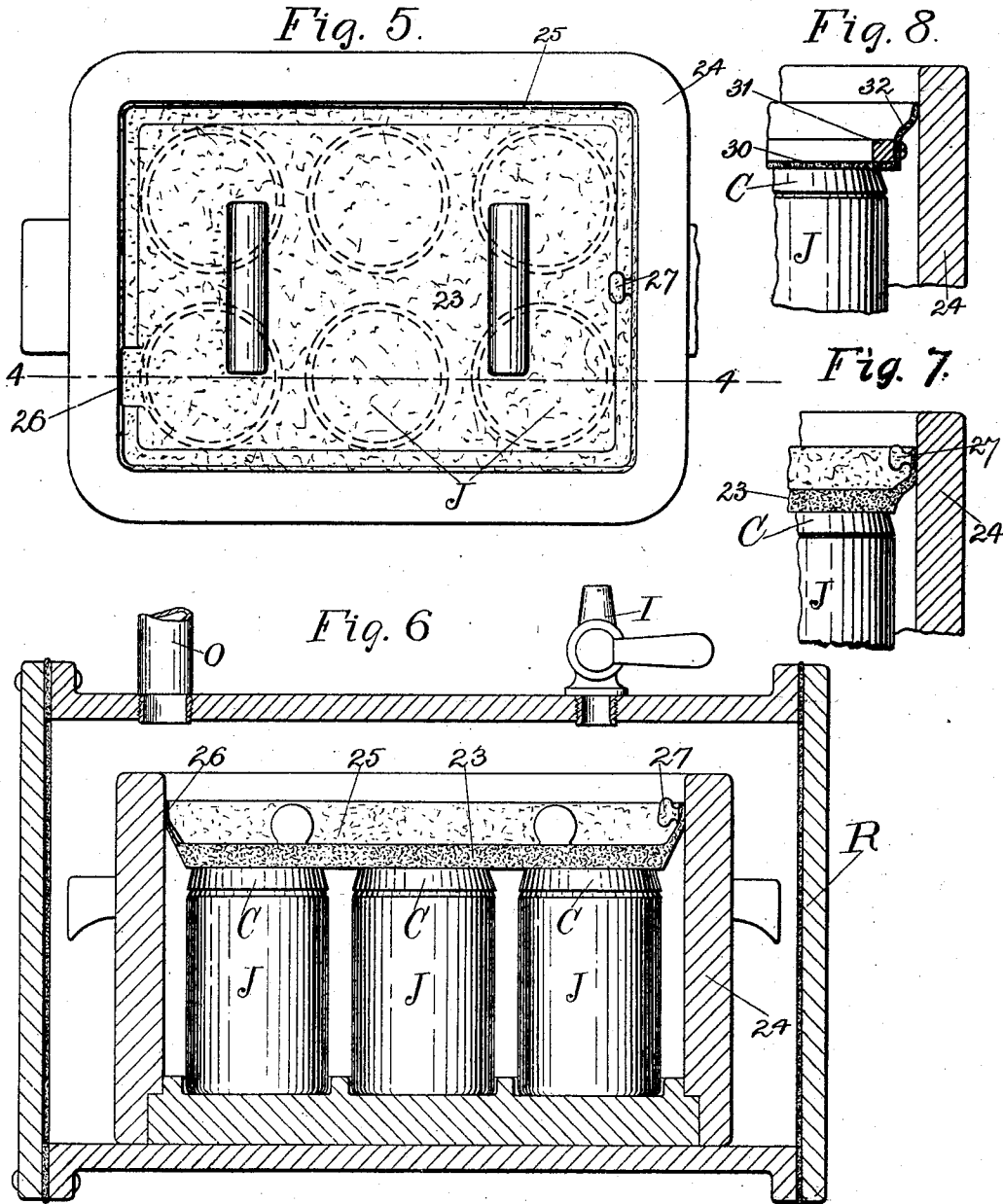

Witnesses:
Joseph Merritt
H. Mallin

Inventors
William A. Lorenz
W. H. Honiss.

UNITED STATES PATENT OFFICE.

WILLIAM A. LORENZ AND WILLIAM H. HONISS, OF HARTFORD, CONNECTICUT, ASSIGNORS TO THEMSELVES, AND BEECH-NUT PACKING COMPANY, OF CANAJOHARIE, NEW YORK, A CORPORATION OF NEW YORK.

JAR-SEALING APPARATUS.

SPECIFICATION forming part of Letters Patent No. 711,432, dated October 14, 1902.

Application filed January 5, 1901. Serial No. 42,175. (No model.)

To all whom it may concern:

Be it known that we, WILLIAM A. LORENZ and WILLIAM H. HONISS, citizens of the United States of America, and residents of Hartford, in the county of Hartford and State of Connecticut, have invented certain new and useful Improvements in Jar-Sealing Apparatus, of which the following is a specification.

This invention comprises an improved apparatus for exhausting and hermetically sealing jars, cans, and similar receptacles.

Figure 1 of the drawings is a plan view of this apparatus. Fig. 2 is a side view thereof in section, taken along the line 2 2 of Fig. 1, representing the apparatus loaded with jars and in position within a receiver for the exhausting and sealing operation. Figs. 3 and 4 are fragmentary side views in section, showing in two positions of service a modification of the presser. Fig. 5 is a plan view of a modified form of the presser of the previous figures; and Fig. 6 is a side view thereof in section, taken along the line 6 6, the latter view also representing the apparatus within a receiver. Fig. 7 is a fragmentary side view illustrating the operation of the readmitted air in sealing the edges of the presser of Fig. 6 against the side wall of the receiver. Fig. 8 is a similar fragmentary view illustrating another modified construction of the presser.

Nearly all hermetically-sealed jars are closed after the air is exhausted from the interior of the jar by means of a cap and an annular gasket inclosing the mouth of the jar. During the time that the air is being exhausted it is desirable to allow the caps to rest lightly upon the gaskets in order to permit of the ready exit of the air from the interior of the jar. Hence at this time the caps are liable to become displaced or tilted, either in the handling or by the outward movement of the air, and if the caps are sealed in this tilted position they do not make a satisfactory and permanent joint. Moreover, on account of inequalities and irregularities in the jars, the caps, or the gaskets, or all together, it frequently happens that the caps while thus supported lightly upon the gaskets rest only upon the higher or larger por-

tions thereof, leaving intermediate openings, which while facilitating the ready exit of the air from the jars are liable to allow the subsequently readmitted air-pressure to reënter the jars before the caps are forced down hard enough or far enough to close those openings.

It is the object of this invention to provide an apparatus whereby the caps may, if desired, be allowed to rest loosely upon their gaskets during the exhausting operation without allowing them to become tilted and which will be automatically operated upon by the readmitted air to force the caps squarely down upon the gaskets and seal the jars without allowing any of the readmitted air to reach the interiors of the jars.

Our improved apparatus consists of an open-sided jar-receptacle 6, having a base 7 for supporting and partially inclosing the jars J. The base may be integral with the side of the receptacle 6 or may be a part of the receiver R of the vacuum apparatus. A jar-presser 10 is fitted to the side walls of the receptacle, and this presser is preferably composed of a flat sheet of rubber or similar flexible material substantially impervious to air. The form of presser shown in Figs. 1 and 2 is preferred by us because of its simplicity and inexpensiveness, and when this form is used the interior walls of the receptacle are preferably recessed, as best shown in Fig. 2, to provide a shoulder 8, located substantially at the plane of the tops of the jar-caps C for supporting the margin of the presser 10, and thus forming a practically air-tight joint, sealing the interior of the receptacle against the readmission of the air. It may in some cases be found desirable to employ a weight 9, of suitable material, resting upon the margins of the presser above the shoulders 8, to improve the contact of the presser with those shoulders. It is also advisable to fit the edges of the presser closely against the sides of the recess, which may readily be done by employing a metallic templet for cutting or trimming the edges of the presser 10 to the proper size.

The form of presser shown in Figs. 1 and 2 not only serves to prevent readmission of air to the interior of the receptacle, but is liable

to impede, at least to some extent, the exit of air therefrom during the exhausting operation. Therefore it is desirable to employ in connection with this form of presser an outlet-aperture 13 and a return check-valve 12 for the exit of the air within the jars and their receptacle during the exhausting operation. In order to enable the check-valve to be opened quickly and readily after the apparatus is removed from the receiver, it is preferably provided with an opening-key 14. The key and the valve 12 should be so placed as to be readily accessible to the operator without being liable to accidental or inadvertent displacement, and to this end it is found convenient to place them in a suitable recess in the walls of the receptacle. In order to further protect the key and the valve, a guard 15, consisting of a narrow strip of metal, may be fastened over the recess, leaving sufficient room for the operator to reach the key 14 with his finger. A button, as 16, will be found convenient for lifting and handling the presser.

The mode of operation of this apparatus is as follows: The filled jars being placed in the receptacle with their gaskets and caps in position, the presser 10 is placed in its seat upon the shoulders 8. The weight 9, if employed, is placed in position and the apparatus is transferred to the receiver R, having an outlet or exhaust pipe O and an inlet-valve I. During the exhausting operation the air from the interior of the jars passes freely out between the caps and their gaskets and through the outlet-aperture 13, the return check-valve 12 lifting readily at a very slight pressure. When a suitable vacuum has been produced, the air is readmitted through the inlet-valve I and operates to close the return check-valve 12 and the presser 10 firmly down upon their respective seats, thereby preventing the readmission of air to the interior of the receptacle and of the jars, and therefore excluding it from the jars. The vacuum within the receptacle and the jars being thus maintained, the readmitted air-pressure is exerted to its full extent upon the outer side of the presser, thus forcing the presser downwardly and carrying the caps with it to their sealing positions. The flexibility of the presser 10 enables the pressure to be applied equally upon all of the jars in spite of the variations which often exist in their respective heights.

In the modified form of presser 20 shown in Figs. 3 and 4 the edge of the presser itself is utilized to form a return check-valve. The outlet-aperture 21 is located above the shoulder 8, by which the aperture is closed, as shown in Fig. 4, when the air is readmitted. During the exhausting operation the edge of the presser rises, as in Fig. 3, thus uncovering the aperture, or the height of the shoulder may be such that the jars before sealing may support the presser somewhat above the shoulder, against which it will subsequently

be moved as the readmitted air forces down the caps.

In the modification shown in Figs. 5 and 6 the presser 23 is provided with upwardly-turned edges 25, of a suitable thickness and flexibility to enable them to conform closely to the interior walls of the receptacle 24, thereby enabling those edges to serve as gaskets for hermetically sealing the open side of the receptacle and also enabling the edge or some portion thereof to serve as a return check-valve for the air, permitting its exit during the exhausting operation and preventing its return when readmitted to the receiver R. By reducing the thickness of a portion of the edge, as at 26, that portion will serve well as a valve, opening to very slight interior pressure, while closing against the return pressure and preventing it from reëntering the receptacle. A button 27, attached to one edge of the presser, will enable it to be readily opened by the operator after the receptacle, with its sealed jars, has been removed from the receiver. The mode of operation of this device is like that of the apparatus of Figs. 1 and 2 above described, excepting that the edges of this modified presser will be forced downwardly along the side walls of the receptacle by the readmitted pressure, as substantially illustrated in Fig. 7.

In the modification shown in Fig. 8 the presser 30, which is shown to be considerably thinner than in the preceding figures, is reinforced by a frame 31. The joint between the presser and the side walls of the receptacle is in this case made by means of a flexible gasket 32. The operation of this device is also substantially like that of the forms hereinbefore described.

The jar-receptacle may be adapted to receive any number of jars, and where the nature of their contents permits the jars may be inverted or be placed on their sides. The entire apparatus may also be modified as to construction and arrangement in many ways which will suggest themselves to those skilled in the art.

We claim as our invention—

1. In combination with an exhausting apparatus, a removable open-sided jar-receptacle, and a jar-presser closing the open side of the receptacle, and flexibly movable in relation to each jar.

2. In a jar-sealing apparatus, the combination of a receiver from which air is exhausted, an open-sided jar-receptacle for containing jars, a flexible presser adjacent to the jars or caps and closing the open side of the receptacle, means for exhausting air from the receiver and the receptacle, and means for readmitting air to the receiver and directing it to automatically press the jars and caps together.

3. In a jar-sealing apparatus, the combination of an open-sided jar-receptacle, a flexible jar-presser substantially closing the open side of the receptacle, means for exhausting the

air from both sides of the presser, and means for readmitting air-pressure and directing it against the outer side of the presser.

4. In a jar-sealing apparatus, the combination of an open-sided jar-receptacle, a flexible jar-presser closing the open side of the receptacle, a seat in the receptacle for the marginal edges of the presser, means for exhausting the air from both sides of the presser, and means for readmitting the air-pressure and directing it against the outer side of the presser.

5. In a jar-sealing apparatus, the combination of an open-sided jar-receptacle, a flexible jar-presser closing the open side of the receptacle, means for holding the marginal edge of the presser in contact with the receptacle, means for exhausting air from both sides of the presser, and means for readmitting the air-pressure and directing it against the outer side of the presser.

6. In combination with an exhausting apparatus, a removable open-sided jar-receptacle, a flexible jar-presser for hermetically closing the open side of the receptacle, and a return check-valve.

7. In a jar-sealing apparatus, the combination of an open-sided jar-receptacle, a flexible jar-presser having a flexible edge for closing the open side of the receptacle, means for exhausting air from both sides of the presser, and means for readmitting the air-pressure and directing it against the outer side of the presser.

Signed at Hartford, Connecticut, this 29th day of December, 1900.

WILLIAM A. LORENZ.
WM. H. HONISS.

Witnesses:

JOSEPH MERRITT,
CHAS. F. SCHMELZ.