

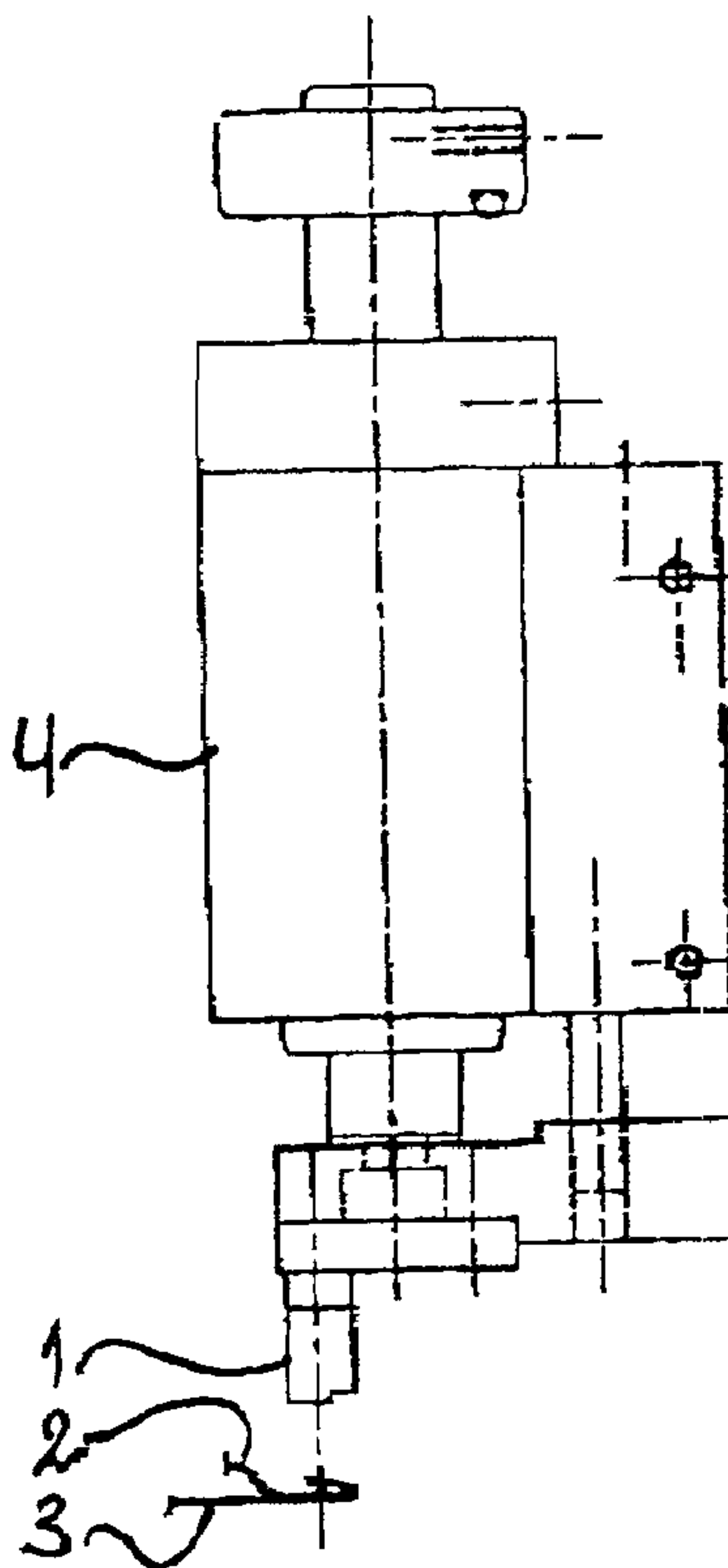

(86) Date de dépôt PCT/PCT Filing Date: 2004/05/25
 (87) Date publication PCT/PCT Publication Date: 2005/12/08
 (45) Date de délivrance/Issue Date: 2011/03/29
 (85) Entrée phase nationale/National Entry: 2006/11/03
 (86) N° demande PCT/PCT Application No.: EP 2004/005752
 (87) N° publication PCT/PCT Publication No.: 2005/115675

(51) Cl.Int./Int.Cl. *B23K 11/14* (2006.01),
B23K 11/00 (2006.01), *B23K 11/25* (2006.01)
 (72) Inventeur/Inventor:
PIETERMAN, KAREL, NL
 (73) Propriétaire/Owner:
AL-S TECHNOLOGY BV, NL
 (74) Agent: MCFADDEN, FINCHAM

(54) Titre : PROCÉDE ET SYSTÈME POUR CONTROLER DES SOUDURES SUR BOSSAGE DE MANIÈRE NON DESTRUCTIVE ET EN TEMPS REEL ET SYSTÈME POUR METTRE EN OEUVRE CE PROCÉDE, COMPRENANT DES MOYENS DE DETECTION DE FORCE ET DES MOYENS DE DETECTION DE DEPLACEMENT
 (54) Title: METHOD AND SYSTEM FOR REAL-TIME NON-DESTRUCTIVE TESTING OF PROJECTION WELDS AND SYSTEM FOR IMPLEMENTING SUCH A METHOD COMPRISING FORCE SENSOR MEANS AND DISPLACEMENT SENSOR MEANS



(57) Abrégé/Abstract:

The present invention generally relates to a method for manufacturing a projection weld connection between at least two parts (2,3) of a workpiece, whereby said workpiece remains blemish free, whereby said method is characterized by the fact that it

(57) **Abrégé(suite)/Abstract(continued):**

comprises automated real-time verification of the quality of the individual weld, with out the use of destructive testing. The invention also relates to a system (1,4) implementing said method comprising, among other features, force sensor means and displacement sensor means.

(12) INTERNATIONAL APPLICATION PUBLISHED UNDER THE PATENT COOPERATION TREATY (PCT)

(19) World Intellectual Property
Organization
International Bureau



(43) International Publication Date
8 December 2005 (08.12.2005)

PCT

(10) International Publication Number
WO 2005/115675 A1

(51) International Patent Classification⁷: **B23K 11/14**,
11/00, 11/25

(21) International Application Number:
PCT/EP2004/005752

(22) International Filing Date: 25 May 2004 (25.05.2004)

(25) Filing Language: English

(26) Publication Language: English

(71) Applicant: **AL-S TECHNOLOGY BV** [NL/NL]; Print-
erweg 39, NL-3800 AP Amersfoort (NL).

(72) Inventor: **PIETERMAN, Karel**; Australiëring 61,
NL-3823 XL Amersfoort (NL).

(74) Common Representative: **VAN ASSEN, Jann Willem
Bernard**; Verbeekstraat 8, 2332 CA Leiden (NL).

(81) Designated States (*unless otherwise indicated, for every
kind of national protection available*): AE, AG, AL, AM,

AT, AU, AZ, BA, BB, BG, BR, BW, BY, BZ, CA, CH, CN,
CO, CR, CU, CZ, DE, DK, DM, DZ, EC, EE, EG, ES, FI,
GB, GD, GE, GH, GM, HR, HU, ID, IL, IN, IS, JP, KE,
KG, KP, KR, KZ, LC, LK, LR, LS, LT, LU, LV, MA, MD,
MG, MK, MN, MW, MX, MZ, NA, NI, NO, NZ, OM, PG,
PH, PL, PT, RO, RU, SC, SD, SE, SG, SK, SL, SY, TJ, TM,
TN, TR, TT, TZ, UA, UG, US, UZ, VC, VN, YU, ZA, ZM,
ZW.

(84) Designated States (*unless otherwise indicated, for every
kind of regional protection available*): ARIPO (BW, GH,
GM, KE, LS, MW, MZ, NA, SD, SL, SZ, TZ, UG, ZM,
ZW), Eurasian (AM, AZ, BY, KG, KZ, MD, RU, TJ, TM),
European (AT, BE, BG, CH, CY, CZ, DE, DK, EE, ES, FI,
FR, GB, GR, HU, IE, IT, LU, MC, NL, PL, PT, RO, SE, SI,
SK, TR), OAPI (BF, BJ, CF, CG, CI, CM, GA, GN, GQ,
GW, ML, MR, NE, SN, TD, TG).

Published:

— with international search report

*For two-letter codes and other abbreviations, refer to the "Guid-
ance Notes on Codes and Abbreviations" appearing at the begin-
ning of each regular issue of the PCT Gazette.*

(54) Title: METHOD AND SYSTEM FOR REAL-TIME NON-DESTRUCTIVE TESTING OF PROJECTION WELDS AND SYSTEM FOR IMPLEMENTING SUCH A METHOD COMPRISING FORCE SENSOR MEANS AND DISPLACEMENT SENSOR MEANS

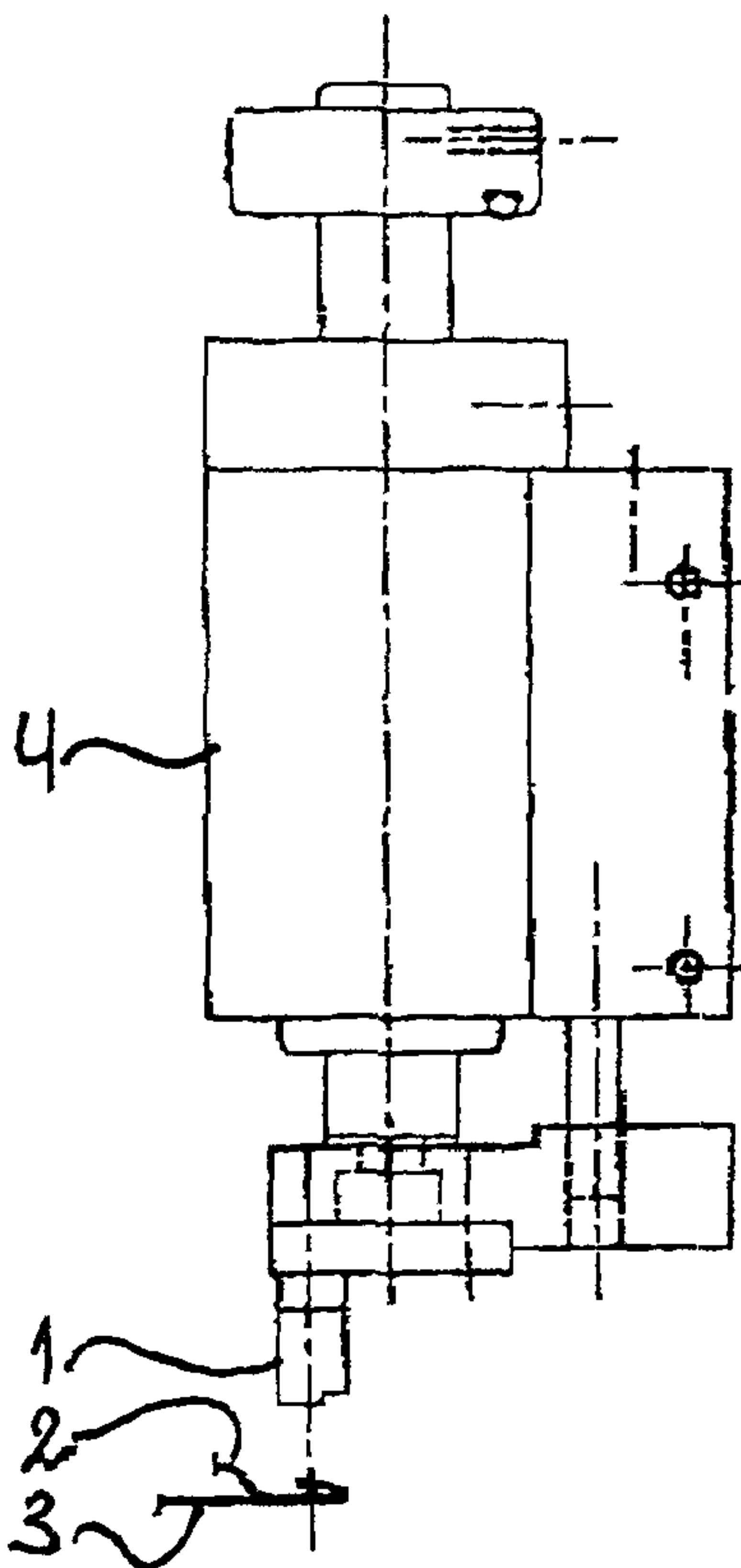

(57) Abstract: The present invention generally relates to a method for manufacturing a projection weld connection between at least two parts (2,3) of a workpiece, whereby said workpiece remains blemish free, whereby said method is characterized by the fact that it comprises automated real-time verification of the quality of the individual weld, with out the use of destructive testing. The invention also relates to a system (1,4) implementing said method comprising, among other features, force sensor means and displacement sensor means.

WO 2005/115675 A1

METHOD AND SYSTEM FOR REAL-TIME NON-DESTRUCTIVE TESTING OF PROJECTION WELDS AND SYSTEM FOR IMPLEMENTING SUCH A METHOD COMPRISING FORCE SENSOR MEANS AND DISPLACEMENT SENSOR MEANS

The present invention generally relates to a method
5 for manufacturing a projection weld connection between at least two parts of a workpiece, whereby said workpiece remains blemish free, characterised by the fact that said method comprises automated real-time verification of the quality of the individual weld, without the use of des-
10 tructive testing, and the invention also relates to a system implementing the method.

The present invention concerns the well-known process of projection welding. In this process a first part of a
15 workpiece, for instance a metal plate, has a protruding deformation that is generally referred to as 'projection'. If this part of the workpiece is to be welded to a second part of the workpiece, for instance also a metal plate, both parts are mechanically pressed together at the
20 location of the projection and a pulse of current of short duration is applied at this same location. This causes the two parts to be welded together at the location of the projection.

A serious disadvantage of this type of welding
25 process used to be the fact that the welding electrode leaves a visible imprint in the outer plate surface, that requires further finishing by for instance grinding. US patent 6 455 801 provides a solution to this disadvantage and makes it possible to manufacture a projection weld and
30 leave the parts to be welded blemish free. The present invention as described below, uses one of the methods known from prior art, for instance the method described in the aforementioned patent, that make it possible to manufacture a projection weld without leaving visible traces on the

workpiece.

A further serious disadvantage of present methods for projection welding is the fact that, for instance in industrial welding, where many welds may be present in the same workpiece, it is very difficult to verify if an individual weld has been manufactured according to the required quality standards. Present systems known from prior art use current monitoring systems to determine the quality of projection welds produced. These systems only give a general indication of the average quality of a series of welds, but can not determine weld quality for an individual weld. Presently the only systems available that enable testing of weld quality of individual welds are highly sophisticated and costly measuring systems. Application of such systems is economically infeasible for most industrial applications of projection welding.

A third point of interest is the fact that the quality of a resulting weld in projection welding depends to a large extent on factors like the shape, dimensions and structural integrity of the projections. If these are flawed, for instance the height of a projection is not according to standards, the projection is not present at all or the projection has structural damage, the melting of the projection during the welding process does not take place in a controlled way which may result not only in an inadequate weld connection, but may also cause structural damage to the workpiece. In case of a flawed projection, no welding current should be applied to avoid further damage. For this, however, it is necessary to verify the dimensional and structural integrity of every projection, just before the welding current is applied. Systems presently known from prior art do not provide an adequate solution for this requirement.

The present invention aims to remedy the aforementioned disadvantages associated with the prior art. To achieve this a method for manufacturing a projection weld connection between at least two parts of a workpiece is proposed, whereby said workpiece remains blemish free, characterised by the fact that said method comprises automated real-time verification of the quality of the individual weld, without the use of destructive testing and without the need for costly sophisticated equipment.

10 A system implementing the method according to the present invention is also proposed.

A further advantageous aspect of the method according to the present invention, is the fact that a measure of the quality of every individual weld produced can be calculated automatically from real-time measurement of one or more parameters of the welding process.

The method for manufacturing a projection weld according to the present invention, is furthermore advantageously characterised by the fact that said method comprises automated verification of the structural integrity of the projection in the workpiece before the welding current is applied.

25 In addition to the aforementioned aspects of the method for manufacturing a projection weld according to the invention, the method is characterised by the fact that said method further comprises automated verification of the dimensional integrity of the projection in the workpiece before the welding current is applied.

The invention further proposes a system implementing the method of the present invention, whereby said system is

characterised by the fact that it at least comprises:

- a welding head suitable for projection welding;
- positioning means to position said welding head on a first part of at least two parts of a workpiece, between
5 which a projection weld has to be established;
- driving means mechanically connected to said welding head, enabling exercising such vertical force on said first part of said workpiece by means of the welding head, that said first part is pressed onto a second part of
10 same workpiece. This driving means may be of any suitable type, for instance pneumatic, hydraulic, electro motor and may be mechanically connected to the welding head by means of a driving shaft;
- force sensor means enabling measurement of the
15 mechanical force that said welding head exercises on the workpiece;
- displacement sensor means enabling measurement of the vertical displacement of said welding head;
- power transformer with low inductance which has one
20 terminal of the secondary side electrically connected to the welding head and the other terminal electrically connected to the workpiece.

In a preferred embodiment of the system according to
25 the invention the mechanical connection between said driving system and said welding head comprises at least one part that is made of a compressible material which exhibits a constant ratio between mechanical force applied to the material, and the resulting displacement. Such part of
30 compressible material may be part of a driving shaft between a piston and the welding head.

Said force sensor in the system according to the present invention may advantageously be a piezo-electric

force sensor.

A system implementing the method according to the present invention may furthermore advantageously be characterised by the fact that said system comprises electronic means that at least provide the following functionalities:

- control of said driving means to regulate the force that is exercised by said welding head on said workpiece. This can for instance be achieved by commonly available microcontrollers;
- control of the welding current by switching on or off said power transformer;
- measurement of the current through said secondary terminals of said power transformer;
- read out, conversion and storage of the signals provided by said pressure sensor means and said displacement sensor means. Many of the commonly available sensors even comprise integrated electronic means that deliver the measurement values in digital form, which facilitates datacommunication, conversion and storage of the measurements;
- storage of relevant data for each individual weld created;
- data communication with external datacommunications or telecommunications equipment or networks;
- input of data and control information by means of a keypad;
- output of data and control information by means of a display. This may be for instance a Liquid Crystal Display (LCD) or a standard CRT monitor of suitable type.

The aforementioned electronic means of the system according to the present invention may advantageously

comprise a microprocessor. Almost any standard microprocessor will nowadays be able to provide most of the aforementioned functionalities.

5 Because welding processes may be hazardous to the human health and because of the fact that many industrial welding processes are highly automated, some of said electronic means of the system according to the present invention may advantageously be located in a remote system
10 unit that is connected to the rest of the system by means of an electric cable or by means of other suitable datacommunications or telecommunications means. This enables control of the system from, for instance, a central control room.

15

For some applications it may be advantageous that said remote system unit of the system according to the present invention is a hand-held terminal.

20 In the following a preferred embodiment of a system implementing the method according to the present invention will be described. The following description and the attached drawings will show to the reader in more detail how the invention remedies the aforementioned disadvantages
25 associated with the prior art. However, the reader should observe that description and drawings are merely meant to illustrate application of the invention and should in no way be regarded as limiting the scope of the present invention.

30

Figures 1A - 1C show partly cross-sectional views of a specific embodiment of the system implementing the method according to the present invention;

Figure 2 shows a partly cross-sectional view of a

slightly modified embodiment of the system implementing the method according to the present invention;

Figure 3 shows a typical time-force curve which has
5 resulted from measurements during manufacture of an adequate projection weld with the system implementing the method according to the present invention; and

Figure 4 is a flow diagram showing the relationship
between the measurements of force and current and the
10 verification of the structural integrity of the projection and the quality of the weld.

Figures 1A - 1C show a particular embodiment of a system implementing the method according to the present invention for manufacturing a projection weld connection between at least
15 two parts of a workpiece. In the Figures 1A - 1C two plate material parts (2) and (3) of a workpiece are to be welded together using projection welding. The system comprises a welding head (1) that is suitable for projection welding. In this example we assume that the upper part (2) of the
20 workpiece has an upwardly protruding deformation (not shown in the figures) which shall hereafter be referred to as the 'projection'. This projection is located under welding head (1) where the dashed line through the welding head (1) intersects the plate material parts (2) and (3). The lower
25 part (3) is furthermore folded back around the edge of the upper part (2) in such a way that the piece of plate material that is folded back, extends over the area where the projection is located. This particular configuration of the plate material parts (2) and (3) has been proposed in US
30 Patent 6 455 801 as a method for manufacturing projection welds in plate material parts leaving the welded parts blemish free. In this example it is merely used to illustrate the general state of the art and shall in no way be regarded as limiting application of the present invention. The system
35 implementing the method according to the present invention

furthermore comprises driving means (4) mechanically connected to welding head (1) and suitable to exercise such vertical force on the welding head that the plate material parts (2) and (3) and the folded-back part of part (3) are pressed together in the area where the projection is situated. In this example a piston driving means is assumed, which is operated pneumatically. The system also comprises a power transformer (not shown in the figures) with low inductance which has one terminal of the secondary side electrically connected to the welding head, and the other terminal electrically connected to the workpiece. The mechanical connection between the driving means and welding head (1) further comprises a part that is made of a compressible material which exhibits a constant ratio between mechanical force applied to the material, and the resulting displacement. The function of said compressible part is in this particular embodiment of a system implementing the method of the present invention performed by a mechanical spring (6) (shown in Figure 2) located within driving means (4). Now if this system would be used in standard projection welding, as shown in Figures 1A - 1C, the driving means would be operated to lower the welding head (1) onto the folded-back part of plate material part (3) and said folded-back part and the plate material parts (2) and (3) would be pressed together at the location of the projection. Then a pulse of current of short duration would be applied through the welding head (1) and the plate material parts (2) and (3) would be welded together at the location of the projection. As mentioned earlier standard projection welding methods and systems presently do not offer adequate and economically feasible solutions for reliable real-time testing of the weld quality of individual projection welds, which may have serious

consequences like, for instance, inadequate weld connections or serious structural damage to the workpiece. To enable reliable testing of individual projection welds, the system implementing the method according to the present invention further comprises a force sensor means enabling measurement of the mechanical force that the welding head (1) exercises on the plate material parts (2) and (3) of the workpiece, and a displacement sensor means enabling measurement of the vertical displacement of said welding head. Said force sensor means may advantageously be a piezo-electric force sensor. Figure 2 shows an embodiment of the system implementing the method of the present invention with a piezo-electric force sensor located in the mechanical connection between the driving means (4) and the welding head (1). With the system implementing the method according to the present invention it is also possible to measure the current through the secondary terminals of the power transformer, which are electrically connected to the welding head (1) and the workpiece consisting of plate material parts (2) and (3) respectively. For the sake of clarity of this description the following assumption is made: to enable verification of the structural integrity of a projection, the average amount of pressure that the projection must be able to withstand when it is undamaged and structurally correct, is known before the welding current is applied.

In this particular embodiment of a system implementing the method according to the present invention the system is operated by means of a hand-held terminal, connected to the rest of the system by commonly known connection means and methods, and equipped with a microprocessor and a suitable software program, a keyboard and a liquid crystal (LCD) display. The hand-held terminal is furthermore equipped with commonly known electronic

means enabling:

- control of the driving means (4) to regulate the force that is exercised by the welding head (1) on the workpiece;
- control of the welding current by switching on or off
5 said power transformer;
- measurement of the current through said secondary terminals of said power transformer;
- read out, conversion and storage of the measurement signals provided by said piezo-electric force sensor and
10 said displacement sensor means;
- storage of relevant data for each individual weld created;
- data communication with external datacommunications or telecommunications equipment or networks.

15 Using the described embodiment of a system implementing the method of the invention, the process to manufacture a projection weld passes through the following stages:

- the welding head (1) is positioned on the workpiece
20 consisting of the two plate material parts (2) and (3), directly above the said projection in part (3);
- a valve is opened and compressed air flows into the piston of driving means (4) causing the welding head (1) to start exercising a mechanical force on the workpiece;
- 25 - if a predetermined force has been reached and the displacement sensor has not measured any unusual vertical displacement since the force was applied, it is assumed that the structural integrity of the projection is correct. If there would have been however unusual vertical
30 displacement, it would be assumed that there, for instance, was no projection present in the plate material part (3) or that it collapsed prematurely. In this case the welding process is aborted to avoid structural damage to the workpiece caused by applying the welding current to a

flawed projection;

- an electronic power switch is activated and the welding current is applied;

5 - during the usual melting and collapse of the projection causing the two parts of the workpiece to be welded together, the vertical force on the workpiece, the vertical displacement of the welding head (1) and the welding current are measured continuously and the measured values are stored in said hand-
10 held terminal;

- the microprocessor in the hand-held terminal processes the measurements and compares the resulting characteristics to average characteristics of projection welding processes that have resulted in adequate weld connections. If the
15 characteristics match within certain boundaries, it is concluded that an adequate projection weld has been achieved and the process is repeated for the next weld.

Figure 3 shows a typical time-force curve which has resulted from measurements during manufacture of an adequate
20 projection weld with the system implementing the method according to the present invention. It can be seen in the figure that the force is increased until a predetermined level has been reached from which can be concluded that the projection was structurally correct. Then the welding current
25 is applied during a few milliseconds. It can be seen that the force decreases very rapidly when the projection melts and collapses. The welding current is switched off and a constant force remains to press the parts of the workpiece together until an adequate projection weld has been achieved.

30 With reference to Figure 4, this figure shows flow diagram describing the relationship between the measurements of force and current and the verification of the structural integrity of the projection (first decision) and the quality of the weld (second decision).

35

11a

The method according to the present invention for
manufacturing a projection weld connection between at least
5 two parts of a workpiece, and the system implementing said
method offers a solution that enables reliable real-time

10

15

20

25

30

testing of the quality of projection welds. This may avoid serious structural damage to the workpieces, and can provide valuable data to assure a permanent high quality of the projection welds in industrial welding processes, for
5 instance by early detection of wear of stamps that are used to create projections in the material of parts that are to be welded together, so that maintenance can be scheduled efficiently. In addition to this it enables to store data concerning every single projection weld for later
10 reference.

All parts of the described embodiment of the system implementing the method of the present invention are commonly available and can be manufactured by using com-
15 monly available materials and commonly known production methods.

CLAIMS:

1. A method of manufacturing a projection weld connection for plates of a workpiece wherein one of the plates to be welded has a projection, the method comprising the steps of:

placing the plates to overlap each other to provide an upper plate and a lower plate;

pressing the plates from one side at a location of the projection with driving means connected to a welding head;

welding the plates together at the location of the projection with a pulse of current of a short duration, the current being applied to the upper plate from a side of the driving means and being removed from the lower plate which workpiece remains blemish free on a side opposite the location of the projection,

wherein the structural integrity of the projection in the workpiece is automatically verified before the welding current is applied, which structural integrity of the projection in said workpiece is verified by measuring with one force sensor in the welding head and a compressible part in the driving means whether said projection can withstand a predetermined mechanical pressure exercised by the welding head and automated real time verification of the quality of the weld by continuously measuring the weld force in the welding head during the weld operation, without the use of destructive testing.

2. The method for manufacturing a projection weld according to claim 1, wherein said one force sensor is a piezo-electric force sensor.

3. The method for manufacturing a projection weld

- 14 -

according to claim 1 or 2, wherein continuous measurements of the pressure exercised by the welding head on the workpiece, welding current are carried out during the welding and are stored to determine a quality measure for every individual projection weld.

4. A system for implementing the method of any one of claims 1 to 3, comprising:

a welding head suitable for projection welding;

positioning means to position said welding head on a first part of at least two parts of the workpiece, between which a projection weld has to be established;

driving means mechanically connected to said welding head and containing a compressible part enabling exercising a vertical force on said first part of said workpiece by means of the welding head such that said first part is pressed onto a second part of the workpiece;

a power transformer with low inductance which has one terminal of a secondary side electrically connected to the welding head and the other terminal electrically connected to the workpiece, characterized in that, said system further comprises electronic means that at least provide the following functionalities;

control of said driving means to regulate the force that is exercised by said welding head on said workpiece;

control of the welding current by switching on/off said power transformer;

force sensor means enabling measurement of a mechanical force that the welding head exercises on the workpiece;

measurement of the mechanical force that the welding head exercises on the workpiece;

- 15 -

measurement of the current through said secondary terminals of said power transformer;

read out, conversion and storage of the welding current and mechanical pressure measurements;

storage of relevant data for each individual weld created;

data communication with external datacommunications or telecommunications equipment of networks;

input of data and control information by means of a keypad;

output of data and control information by means of a display.

5. The system according to claim 4, wherein all of said electronic means except the force regulation and the force sensor are located in a remote system unit that is connected to the force sensor by means of an electric cable or other suitable datacommunications or telecommunications means.

6. The system according to claim 5, wherein said remote system unit is a hand-held terminal.

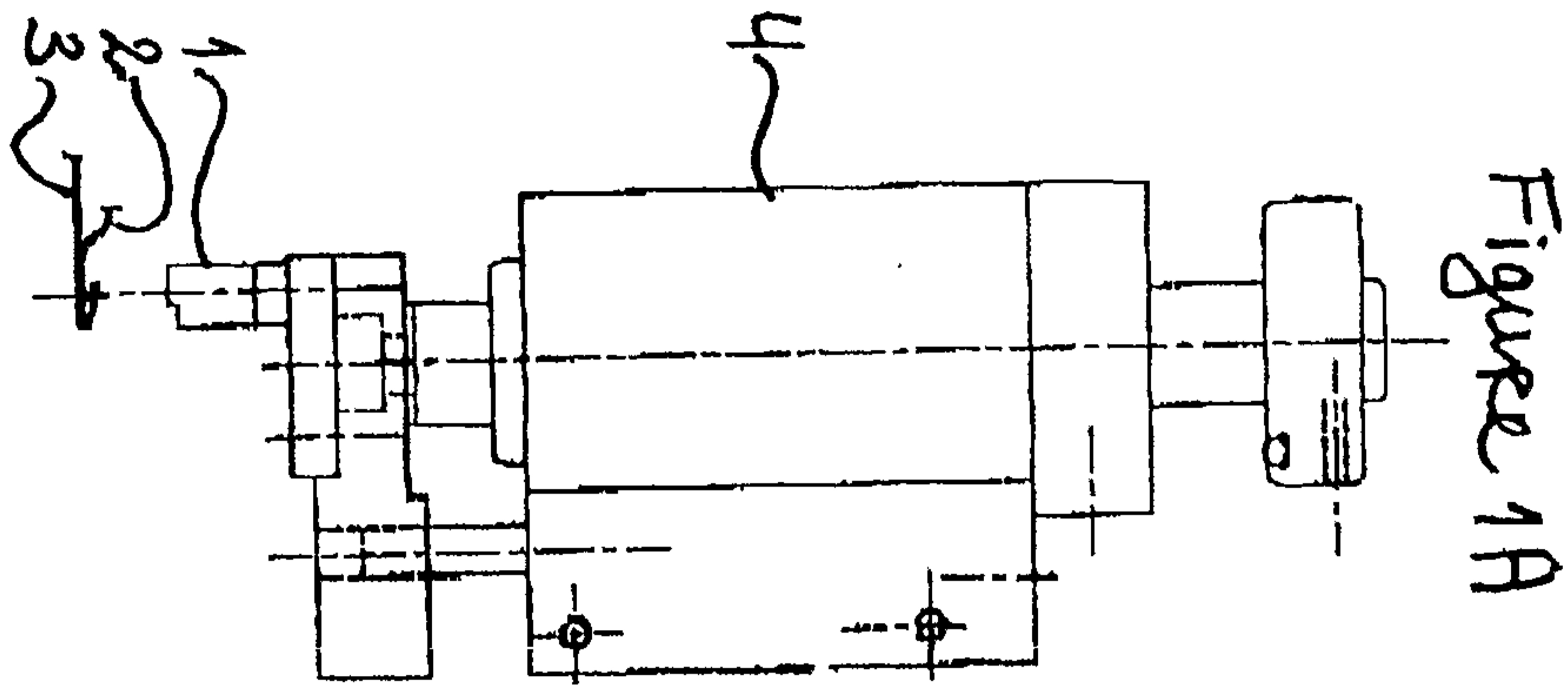

Figure 1A

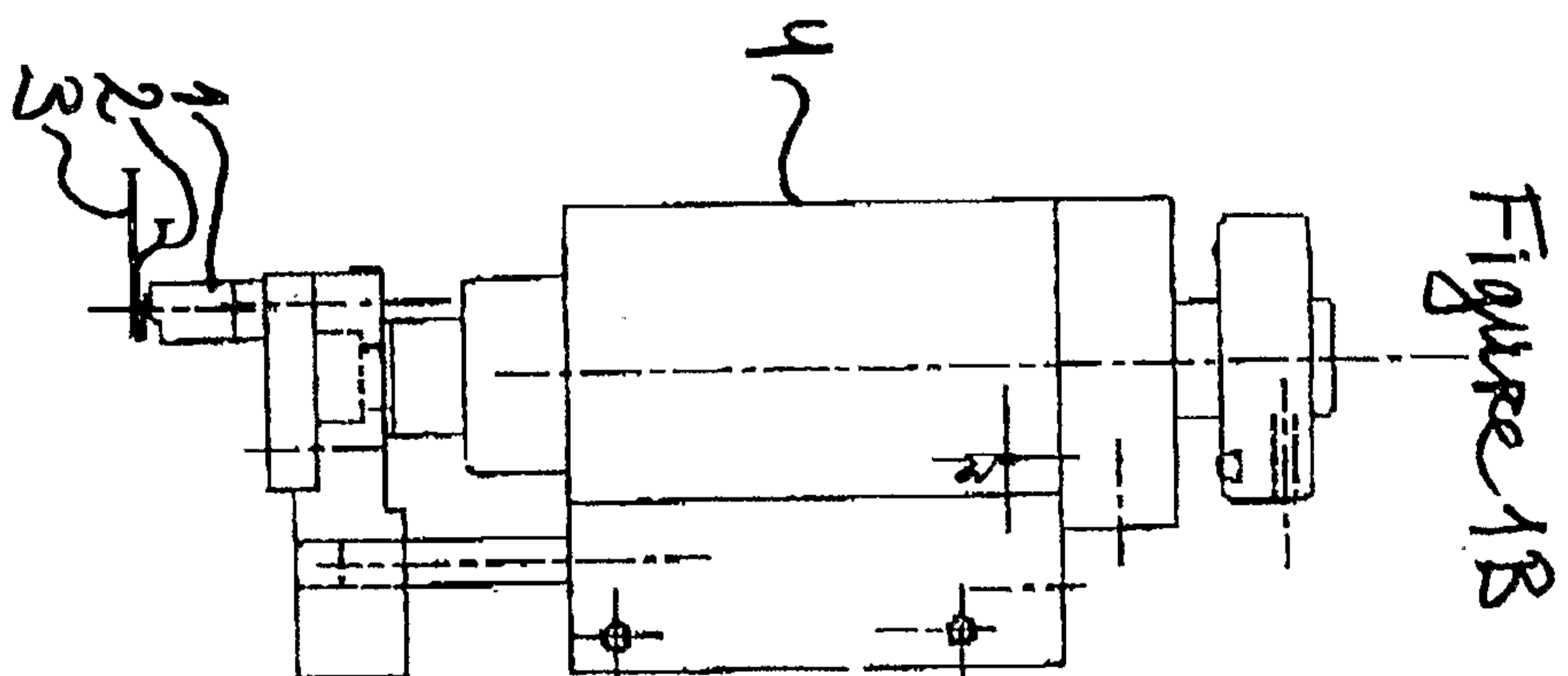

Figure 1B

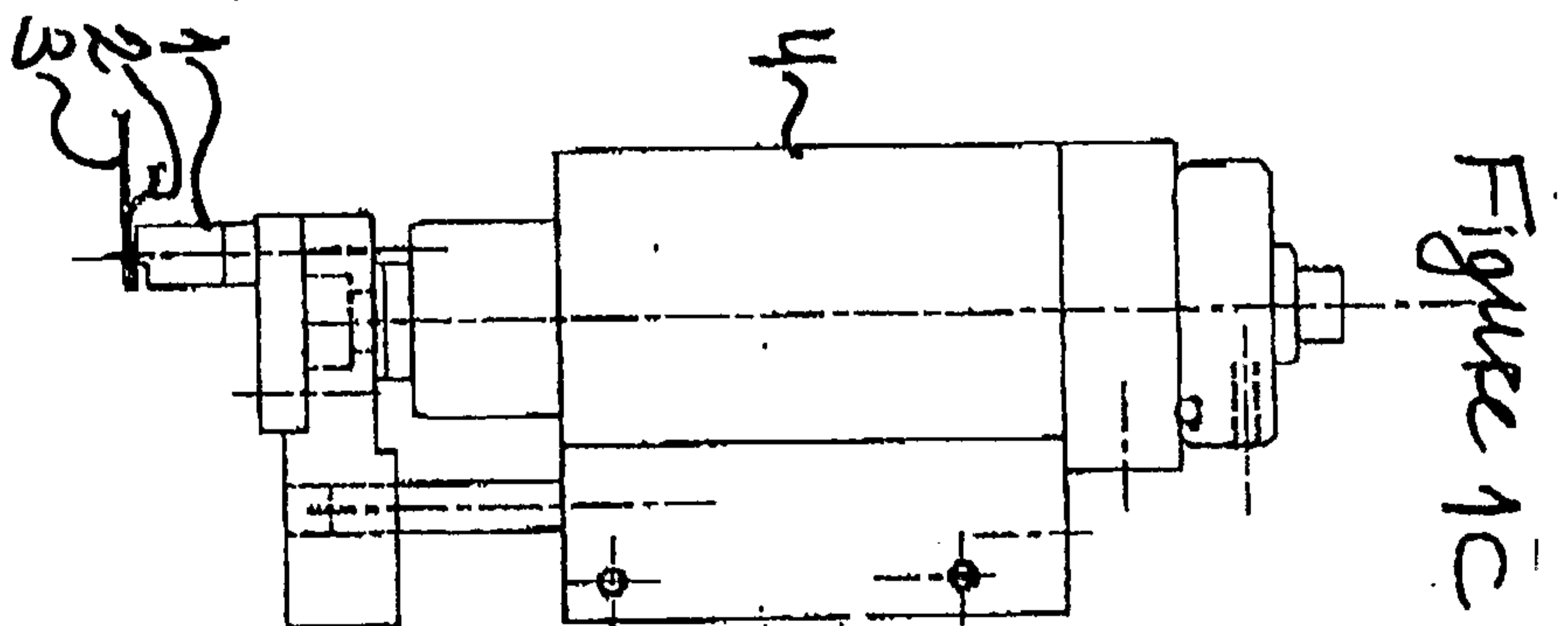

Figure 1C

Figure 2

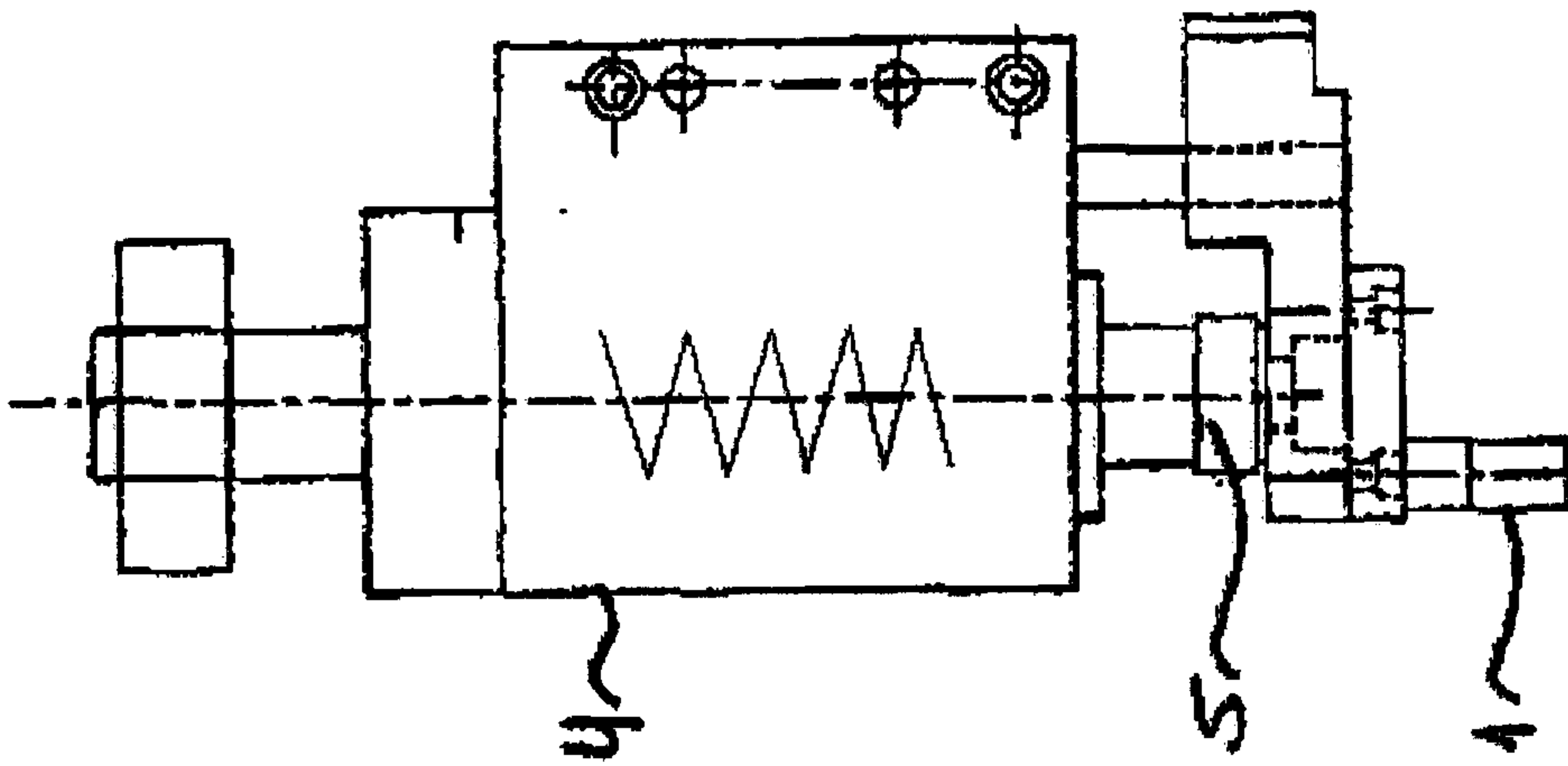

Figure 3

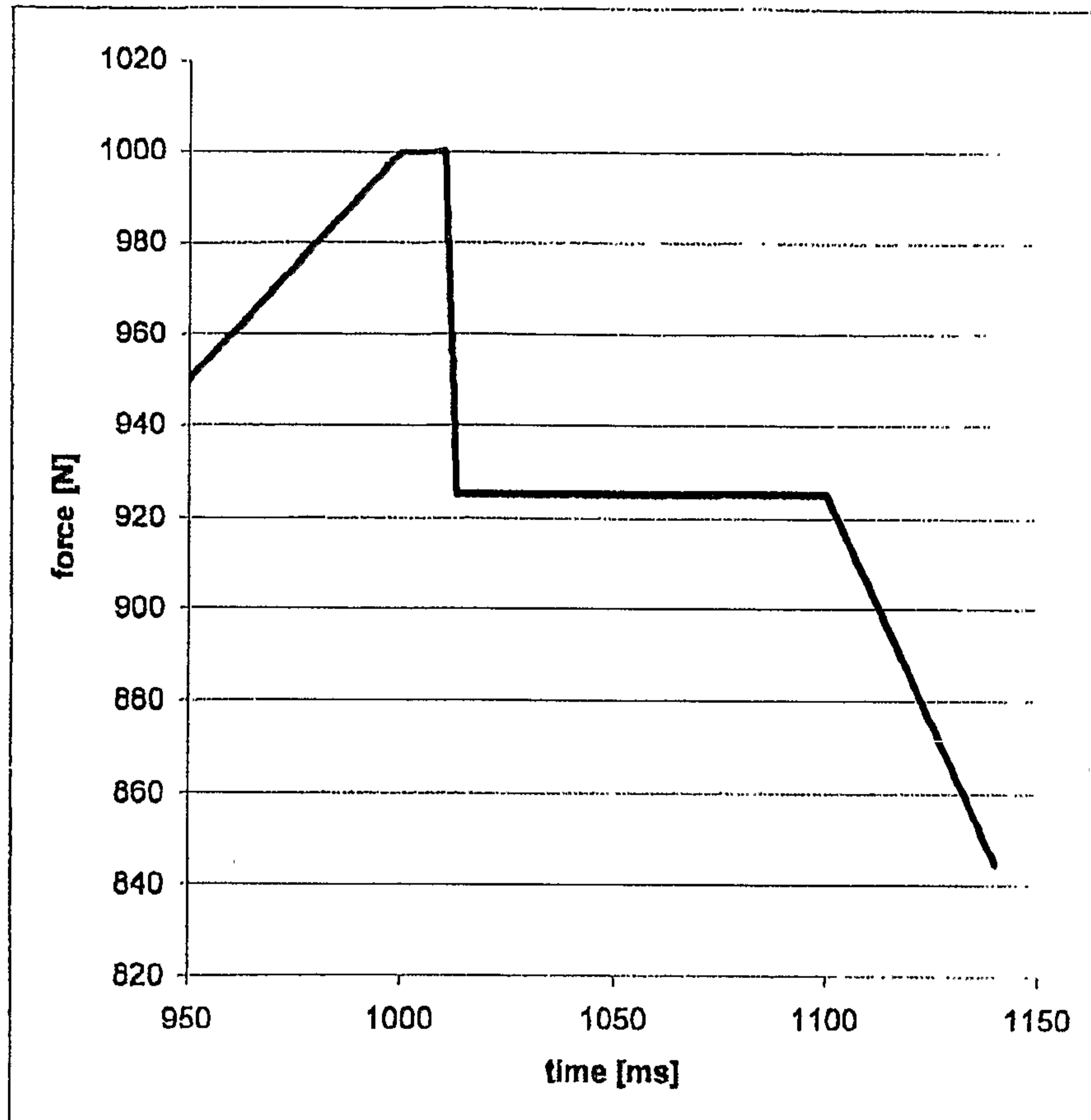

Figure 4

