



INTERNATIONAL APPLICATION PUBLISHED UNDER THE PATENT COOPERATION TREATY (PCT)

<p>(51) International Patent Classification⁴ : B65B 3/06</p>	<p>A1</p>	<p>(11) International Publication Number: WO 90/03919 (43) International Publication Date: 19 April 1990 (19.04.90)</p>
<p>(21) International Application Number: PCT/US89/04465 (22) International Filing Date: 6 October 1989 (06.10.89) (30) Priority data: 257,627 14 October 1988 (14.10.88) US (71) Applicant: ELKAY MANUFACTURING COMPANY [US/US]; 2222 Camden Court, Oak Brook, IL 60521 (US). (72) Inventors: BAKER, Henry, E. ; R.F.D. 2, Northfield Road, Litchfield, CT 06759 (US). BAKER, John, B. ; 306A Maple Street, Litchfield, CT 06759 (US). BAKER, David, H. ; 23 Old Farms Road, Litchfield, CT 06759 (US). BAKER, Peter, K. ; 42 Arch Bridge Road, Bethlehem, CT 06751 (US). DONSELMAN, Edward, H. ; 818 South Saxby Avenue, Freeport, IL 61032 (US). KATZ, Ronald, C. ; 12 Kent Court, Willowbrook, IL 60514 (US).</p>		<p>(74) Agents: SHEPPARD, Berton, Scott et al.; Leydig, Voit & Mayer, One IBM Plaza, Suite 4600, Chicago, IL 60611 (US). (81) Designated States: AT (European patent), AU, BE (European patent), BR, CH (European patent), DE (European patent), DK, FI, FR (European patent), GB (European patent), IT (European patent), JP, KR, NL (European patent), NO, SE (European patent). Published <i>With international search report.</i></p>

(54) Title: LIQUID CONTAINER SUPPORT AND HYGIENIC LIQUID DISPENSING SYSTEM

(57) Abstract

A hygienic liquid dispensing system (10) having a cap (50) to close the opening of an inverted liquid container (15) is disclosed. The cap (50) has a lid portion (53) to overlie and sealingly close the opening and an annular skirt portion (55) extending axially away from the lid (53) to surround a portion of the container neck (51). The lid portion (53) is provided with an axially inwardly extending recess (60) including an outer sleeve (62) and an inner plug portion (70) integrally formed with a frangible connection (75) therebetween. A feed tube (45) is dimensioned for forcible insertion into the recess (60) for breaking the frangible connection (75) and separating the plug portion (70) from the sleeve (62) to permit the discharge of liquid from the container (15). A mounting apparatus (25) is also provided to fit on the upper portion (26) of a cabinet (20) and defines an annular ring (24) for supporting the inverted container (15) thereon which also defines a tapered entry portion (27) extending downwardly and inwardly from the annular ring (24) for receiving the inverted container (15) therein.

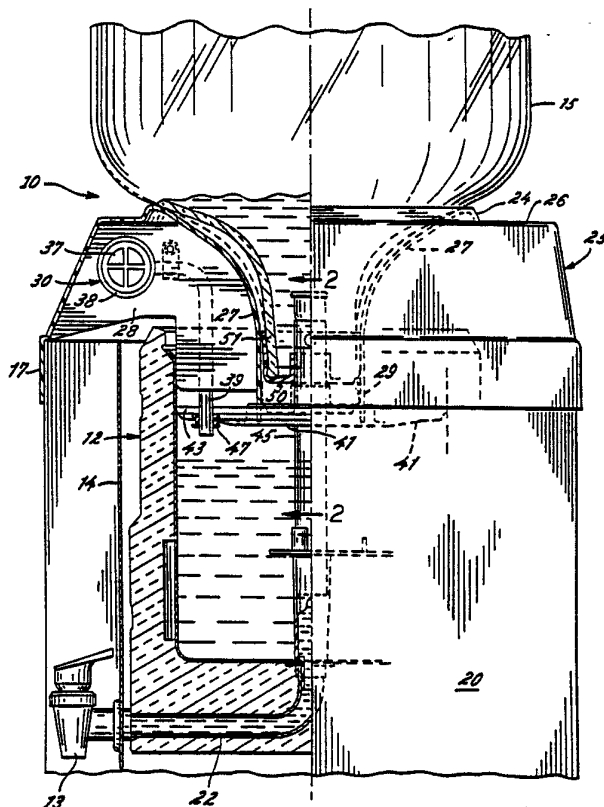

FOR THE PURPOSES OF INFORMATION ONLY

Codes used to identify States party to the PCT on the front pages of pamphlets publishing international applications under the PCT.

AT	Austria	ES	Spain	MG	Madagascar
AU	Australia	FI	Finland	ML	Mali
BB	Barbados	FR	France	MR	Mauritania
BE	Belgium	GA	Gabon	MW	Malawi
BF	Burkina Fasso	GB	United Kingdom	NL	Netherlands
BG	Bulgaria	HU	Hungary	NO	Norway
BJ	Benin	IT	Italy	RO	Romania
BR	Brazil	JP	Japan	SD	Sudan
CA	Canada	KP	Democratic People's Republic of Korea	SE	Sweden
CF	Central African Republic	KR	Republic of Korea	SN	Senegal
CG	Congo	LI	Liechtenstein	SU	Soviet Union
CH	Switzerland	LK	Sri Lanka	TD	Chad
CM	Cameroon	LU	Luxembourg	TG	Togo
DE	Germany, Federal Republic of	MC	Monaco	US	United States of America
DK	Denmark				

LIQUID CONTAINER SUPPORT AND HYGIENIC LIQUID DISPENSING SYSTEMFIELD OF THE INVENTION

The present invention relates generally to liquid dispensers, and more particularly concerns an inverted water bottle container support, hygienic delivery system and a hygienic cap for use in such systems.

BACKGROUND OF THE INVENTION

A cooler and dispenser for bottled water normally has a cooling reservoir within which the inverted neck of a water bottle is disposed. Water flows from the bottle until the water level closes the bottle neck and typically a refrigeration system cools the reservoir and the water being held there. Additionally, some systems are provided with an additional tank, supplied with water from the reservoir, and have a heating system which provides hot water. Water is dispensed by draining the reservoir, usually through a faucet. When the water level falls below the inverted bottle neck, air in the reservoir can enter the bottle, bubble to the top, and release more water to maintain the water level in the reservoir.

Some systems are provided with a cap over the neck of the water bottle so that upon inverting, water is contained until the water bottle is properly inserted into the water cooler. In order to provide fluid communication, these types of water coolers are often provided with a feed tube which pierces the cap upon insertion of the inverted bottle in the cooler and provides a conduit to dispense water into the reservoir. Water coolers of this general type can be found in U.S. Patent No. 4,699,188 to Baker et al.

It sometimes becomes necessary to replace a partially empty water bottle with a new water bottle

containing either the same liquid or a different liquid, or otherwise remove a partially filled water bottle. In conventional systems, however, upon removal, water is discharged through the neck of the water bottle without control. One solution to a similar problem is presented as a resealable plug-type fitting for use with flexible bag containers and is described in U.S. Patent No. Re. 32,354 to Chester Savage, assignor to Scholle Corporation. An improved hygienic liquid dispensing system for use in water bottle coolers which allows for the removal of a partially filled water bottle is necessary.

OBJECTS AND SUMMARY OF THE INVENTION

It is a primary object of the present invention to provide a hygienic liquid dispensing system which allows for the removal of a partially filled liquid container.

It is a related object of the present invention to provide a system whereby removal of the liquid container causes the liquid to be sealed within the container.

It is a more detailed object of the present invention to provide a cap for a water bottle which, upon inverting the water bottle and inserting the water bottle into a water cooler, allows for the flow of water and upon removal of the water bottle will seal any remaining liquid inside the water bottle.

It is an additional object of the present invention to provide a means for retrofitting existing water cooler systems with a hygienic system.

The above objects are accomplished in accordance with the present invention which provides a liquid container support and hygienic delivery system for

dispensing liquid from an inverted container having a depending neck defining an opening into a dischargeable reservoir open at its upper end and housed within a cabinet.

A mounting is adapted to fit on the upper portion of the cabinet and defines an annular ring for supporting the inverted container thereon. The mounting means also defines a tapered entry portion extending downwardly and inwardly from said annular ring for receiving the inverted container neck therein. There is also provided a means for sealingly closing the open upper end of the reservoir and for supporting an upstanding feed tube dimensioned to penetrate into the container neck to provide a hygienic flow path for delivering liquid from the inverted container into the reservoir.

More specifically, a hygienic cap is provided for use with the system having a lid portion adapted to overlie and sealingly close the opening in the bottle neck. Also provided is an annular skirt extending axially away from the lid portion to surround a portion of the bottle neck and an axially inwardly extending recess formed therein including a first annular sleeve portion located generally centrally in the lid portion and integrally connected thereto and a second annular plug portion connected to the inner end of the sleeve portion and extending axially inwardly therefrom. A closed inner end of the plug portion for normally closing the recess is provided and a frangible connection between the plug portion and the sleeve portion is adapted to be broken so that the plug portion axially separates from the sleeve portion when forcibly inserting a feed tube into the recess to permit the discharge of liquid from the container. Additionally, there is

provided a means for retaining the plug portion on the feed tube so that, upon removal of the feed tube, the plug portion is drawn into the sleeve portion of the cap recess and reseals the liquid in the container.

These and other features and advantages of the invention will be more readily apparent upon reading the following description of a preferred exemplified embodiment of the invention and upon reference to the accompanying drawings wherein:

BRIEF DESCRIPTION OF THE DRAWINGS

FIGURE 1 is a fragmentary side elevation view of the water bottle cooler and hygienic liquid dispensing system including the hygienic cap of the present invention, with certain portions broken away in section;

FIG. 2 is a section taken substantially along line 2-2 in FIG. 1 showing the partial insertion of the water bottle in the hygienic liquid dispensing system according to the present invention;

FIGS. 3a and 3b are fragmentary sections taken substantially along line 3-3 in FIG. 2 showing a detachable connection between an adaptor unit of the hygienic liquid dispensing system and an existing water bottle cooler;

FIGS. 4a, 4b and 4c are enlarged, fragmentary side elevation views, partly in section, showing insertion and removal of the feed tube with respect to the hygienic cap in the hygienic liquid dispensing system according to the present invention; and

FIG. 5 is a fragmentary perspective view showing an alternative adaptor unit having a tapered side wall sitting on top of a water cooler housing.

While the invention will be described and

disclosed in connection with certain preferred embodiments and procedures, it is not intended to limit the invention to those specific embodiments. Rather it is intended to cover all such alternative embodiments and modifications as fall within the spirit and scope of the invention.

DETAILED DESCRIPTION OF THE PREFERRED EMBODIMENTS

Turning now to the drawings, there is shown in greater detail, a bottled water cooler 10 including a cabinet 20 of the type having an open-topped cooling reservoir 12 which is disposed to receive the inverted neck of a bottle 15 containing water or the like. Typically, the reservoir 12 and its contents are subjected to temperature control by a refrigeration system and/or a heating system (not shown), in the lower portion of the cabinet 20, and water is taken from the reservoir through a drain pipe 22 and a faucet 13 mounted on a cabinet front panel 14. In the illustrated cooler 10, the front panel 14 is recessed within the cabinet periphery so as to set the faucet 13 back into the cabinet and thus prevent inadvertent contact.

In keeping with the invention, a mounting adapter 25 is disposed on the upper portion of the water cooler cabinet 20. To properly support the inverted water bottle, the mounting adapter 25 is provided with an annular ring 24 on its upper portion 26 and in order to properly receive and guide the inverted water bottle 15, the mounting adapter 25 is provided with a tapered entry portion 27 extending downwardly and inwardly from the annular ring 24 on the upper portion 26 of the mounting adapter 25. The entry portion 27 is formed with a lower end 29 having a length greater than the container neck 51, so that

substantially all of the weight of the inverted water bottle is supported by the annular ring 24 of the mounting adapter 25 rather than by the water bottle neck. In the illustration of FIG. 1, the mounting adapter 25 is provided with downwardly extending side walls 17 and also includes internal stiffening ribs 28 interconnecting the side walls 17, the raised upper portion 26 and the tapered entry portion 27 so as to support the annular ring 24.

As more particularly depicted in FIG. 2, in the preferred embodiment, an annular diaphragm element 41 coupled to the lower end 29 of the entry portion 27 of the mounting adapter 25 sealingly closes the upper portion of the reservoir 12 and supports an upstanding feed tube 45 whose operation is described in greater detail below.

In order that the hygienic liquid dispensing system may be retrofitted to existing water coolers, the diaphragm/feed tube configuration described above carries a flexible peripheral member 43 for sealingly engaging and closing the open end of the reservoir 12. To facilitate the retrofitting between the mounting adapter and an existing water cooler having the diaphragm/feed tube connection, a quick disconnect means is provided having bayonet-type tab fittings 33 on the diaphragm and complementary lugs 34 on the lower end 29 of the entry portion 27 of the mounting adapter 25. As shown in greater detail in FIGS. 3a and 3b, one or more of the bayonet-type tab fittings 33 may be provided with centering detent-like dimples 35 for engagement with complementary recesses 36 formed in the upper surface of the lugs 34 to insure proper engagement of the quick disconnect means. It will be understood, of course, that other suitable attachment means may be provided,

if desired.

Pursuant to another feature of the preferred embodiment, and as depicted in FIGS. 1 and 2, an air filter 30 is provided with a filter element 37, having a filter medium removably fitted on the housing 38 of the filter 30. A conduit 39 is connected to the filter housing 38 and passes via a grommet 47, through the diaphragm element 41, so that air cannot enter the reservoir except by passing through the filter medium. A more detailed description of the filter 30 can be found in U.S. Patent No. 4,834,267, issued May 30, 1989 to Schroer et al. and is hereby incorporated by reference. It will also be appreciated with reference to FIG. 1, that the filter 30 may be conveniently located under the raised upper portion 26 of the mounting adapter 25.

In keeping with the invention, a hygienic cap 50 for a liquid dispensing system is shown in FIGS. 4a, 4b and 4c. As is conventional with water bottles, a neck portion 51 defines a discharge opening through which liquid may dispense. In order to seal liquid within the bottle, hygienic cap 50 is provided with a lid portion 53 adapted to overlie and sealingly close the discharge opening defined by the neck 51. Additionally, an annular skirt portion 55 of the cap 50 extends axially away from the periphery of the lid portion 53 and is adapted to surround a portion of the neck 51 so as to sealingly retain contact with the neck portion 51 of the water bottle. As will become more apparent below, the hygienic cap 50 is provided with an axially inwardly extending recess 60 formed integrally with or otherwise connected to the lid portion 53. The axially inwardly extending recess 60 includes a first annular sleeve portion 62

which is located generally centrally in the lid portion 53 and is preferably integrally connected thereto.

In keeping with the present invention, a second annular plug portion 70 is connected to the inner end of the first annular sleeve portion 62 and extends axially inwardly therefrom. As shown in the illustrated embodiment, the second annular plug portion 70 is provided with a closed inner end 71 to fully seal liquid within the inverted water bottle.

In keeping with another important aspect of the invention, the second annular plug portion 70 is preferably integral with the first annular sleeve portion 62 and is connected thereto through a frangible connection 75 in order to allow the plug portion 70 to be axially separated from the sleeve portion 62 upon the forceable insertion of a feed tube 45 into the inwardly extending recess 60 to facilitate the discharge of liquid from the inverted water bottle. The frangible connection 75 includes an area of the recess which has reduced wall thickness at the inner end of the sleeve 62 where the plug portion 70 is connected thereto. This single piece construction not only reduces assembly time but also avoids separation and loss of the plug portion. To this end, in the preferred embodiment, the cap 50 is formed in a single piece. However, it will be appreciated that a two-piece construction may sometimes be advantageous. In this regard, the multiple pieces may thereafter be assembled in a one-piece configuration either by spin welding, sonic welding, chemical bonding or the like.

In order to temporarily secure the plug 70 on the feed tube 45 when the feed tube is inserted in the recess 60, the plug portion 70 is formed with an

internal gripping rib 72. In a complementary way, so that the feed tube 45 may retain the plug portion 70 upon insertion of the feed tube into the inwardly extending recess 60, feed tube 45 is provided with an annular groove 42 formed in its outside surface. In order to facilitate proper insertion of the feed tube 45 in recess 60, and proper mating engagement between the gripping rib 72 of the plug portion 70 and the annular groove 42 of feed tube 45, feed tube 45 may be provided with an upper portion 44 of reduced diameter and a tapered annular ramp portion 63 adjacent the annular groove 42 for guiding the annular gripping rib 72 into the annular groove 42.

Upon further insertion of the feed tube into the recess 60, the frangible connection 75 is broken, thereby allowing the extension of the feed tube 45 into the neck of the inverted water bottle. In a conventional manner, feed tube 45 is formed with an internal bore 46 and at least one radial inlet 48 communicating therewith to allow the dispensing of liquid from the interior of the inverted water bottle to the reservoir 12 as more fully described in the above mentioned U.S. Patent No. 4,699,188 to Baker et al. As is apparent and in order to allow fluid flow, the inlet 48 is spaced from the end of the feed tube 45 by a distance that is greater than the internal depth of the plug 70.

As shown in FIG. 4b, the exterior surface of the feed tube 45 is dimensioned with respect to the interior of the first annular sleeve portion 62 so that a sealing engagement is effected upon insertion of the feed tube 45 into the recess 60 and the inverted water bottle.

In keeping with another important aspect of the invention, the hygienic liquid dispensing system is

provided with means for resealing the inverted water bottle upon removal of the water bottle from the cooler or, conversely, upon removal of the feed tube from the hygienic cap 50. Upon removal of feed tube 45 from the inverted water bottle 15, annular groove 42 retains the annular plug portion 70 of hygienic cap 50 until the plug portion is fully drawn into the axially inwardly extending recess 60 of lid portion 53. In the preferred embodiment, the plug portion 70 is formed with an outside annular surface dimensioned to sealingly fit within the sleeve portion 62 when the feed tube 45 is withdrawn from the recess 60. For this purpose, the plug 70 is preferably formed with a tapered lead-in section 69 adjacent the frangible connection 75 for guiding the plug 70 into the sleeve 62 when the feed tube 45 is withdrawn from the recess 60. Adjacent its closed end 71, the plug portion 70 is also preferably provided with an annular flange 73 in order to prevent the plug portion 70 from being removed from the hygienic cap 60. In the preferred embodiment, the external annular flange 73 is dimensioned to seat on the inner end of the sleeve 62 when the plug 70 is drawn into the sleeve. Additionally, in order to sealingly engage the plug portion 70 with the first annular sleeve portion 62 of the hygienic cap, plug portion 70 is provided with an external annular recess 77 which sealingly cooperates with a radially inwardly projecting bead 76 of sleeve portion 62. Moreover, this external annular groove/internally projecting bead combination provides a gripping means that will allow the feed tube 45 to mate with and retain the plug portion 70 prior to the plug portion becoming slideably disengaged with respect to the sleeve portion 62.

In the preferred embodiment, a hygienic cap 50 is also provided with a line of weakness 80 on the skirt 55 extending toward the lid portion 53 and a pull tab 85 extending axially from the skirt. Pull tab 85 is provided to facilitate manually tearing the skirt 55 along the line of weakness 80 when the cap 50 is removed from the container. Additionally, the cap is formed to receive a protective seal 84 covering the recess 60 to prevent contaminants from entering therein. The protective seal 84 also serves to indicate whether the cap has been tampered with prior to insertion of the feed tube 45 into the recess 60.

An alternate embodiment of the invention is illustrated in FIG. 5 wherein the mounting adapter 25a is designed to be positioned on top of an existing water cooler 10a having a flat upper surface. The above described hygienic water bottle system having the hygienic cap, feed tube and mounting diaphragm is housed within the cooler 10a, but is not shown here.

We claim as our invention:

1. A hygienic cap for a liquid dispensing container having a neck defining a discharge opening, said cap comprising, in combination, a lid portion adapted to overlie and sealingly close said opening, and an annular skirt portion extending axially away from said lid portion and adapted to surround a portion of said neck, said lid portion having an axially inwardly extending recess formed therein including a first annular sleeve portion located generally centrally in said lid portion and integrally connected thereto and a second annular plug portion connected to the inner end of said sleeve portion and extending axially inwardly therefrom, said plug portion having a closed inner end for normally closing said recess, and means defining a frangible connection between said plug portion and said sleeve portion, said connection being adapted to be broken and said plug portion axially separated from said sleeve portion upon the forceable insertion of a feed tube into said recess in order to permit the discharge of liquid from said container.

2. A hygienic cap as defined in claim 1 wherein said plug is formed with internal gripping means therein for temporarily securing said plug on said feed tube when said feed tube is inserted in said recess and said frangible connection is broken.

3. A hygienic cap as defined in claim 1 wherein said plug is formed with an outside annular surface dimensioned to fit within and seal said sleeve portion when said feed tube is withdrawn from said recess.

4. A hygienic cap as defined in claim 3 wherein said outside annular surface of said plug is formed with sealing means for engaging complementary sealing means formed on the inside of said sleeve portion when said plug is drawn into said sleeve portion.

5. A hygienic cap as defined in claim 4 wherein said plug sealing means includes an annular groove formed in the outside surface thereof and said complementary sleeve sealing means includes a radially inwardly projecting bead dimensioned to seat in said groove when said plug is drawn into said sleeve portion.

6. A hygienic cap as defined in claim 5 wherein said plug portion being dimensioned to reseal said recess when said plug is drawn into said sleeve portion upon the withdrawal of said feed tube therefrom.

7. A hygienic cap as defined in claim 4 wherein said plug sealing means includes an external annular flange formed adjacent the closed end thereof, said flange being dimensioned to seat on the inner end of said sleeve portion when said plug is drawn into said sleeve portion.

8. A hygienic cap as defined in claim 1 wherein said sleeve portion and said plug portion are integrally formed with said cap and said frangible connection includes an area of said recess having a reduced wall thickness at the inner end of said sleeve where said plug portion is connected thereto.

9. A hygienic cap as defined in claim 3 wherein said plug is formed with a tapered lead-in section adjacent said frangible connection for guiding said plug into said sleeve portion when said feed tube is withdrawn from said recess.

10. A hygienic cap as defined in claim 1 wherein said skirt is formed with a line of weakness extending toward said lid portion and a pull tab extending axially from said skirt to facilitate manually tearing said skirt along said line of weakness when said cap is removed from said container.

11. A hygienic cap as defined in claim 1 wherein said lid portion is formed to receive a protective seal covering said recess to prevent contaminants from entering therein and also serving to indicate if said cap has been tampered with prior to insertion of said feed tube into said recess.

12. A hygienic liquid dispensing system comprising, in combination, a cap adapted to close the discharge opening of a liquid container, said cap having a lid portion adapted to overlie and sealingly close said opening and an annular skirt portion extending axially away from said lid portion and adapted to surround a portion of the container neck,

said lid portion having an axially inwardly extending recess formed therein, said recess including an outer sleeve portion and an inner plug portion integrally formed with a frangible connection therebetween, and a feed tube dimensioned for forcible insertion into said recess for breaking said frangible connection and separating said plug portion from said sleeve portion to permit the discharge of liquid from said container.

13. A hygienic dispensing system as defined in claim 12 wherein said plug is formed with internal gripping means therein and said feed tube is formed with complementary external gripping means for securing said plug on said feed tube when said feed tube is inserted in said recess and said frangible connection is broken.

14. A hygienic dispensing system as defined in claim 12 wherein said feed tube is formed with an internal bore and a radial inlet communicating therewith, said inlet being spaced from the end of said feed tube by a distance that is greater than the internal depth of said plug.

15. A hygienic dispensing system as defined in claim 13 wherein said internal gripping means includes a radially inwardly projecting annular lip formed on said plug and said external gripping means includes an annular groove formed in the tip portion of said feed tube.

16. A hygienic dispensing system as defined in claim 15 wherein said feed tube is formed with a tapered annular ramp portion adjacent said groove for guiding said tip into annular lip on said plug.

17. A hygienic dispensing system as defined in claim 15 wherein said feed tube being dimensioned for close fitting sealing relation with the inside diameter of said recess to prevent leakage of liquid therebetween when said feed tube is inserted into said recess.

18. A hygienic dispensing system as defined in claim 15 wherein said feed tube is formed with a tip portion having a reduced cross sectional diameter for insertion into said plug portion of said recess.

19. A liquid container support and hygienic delivery system for dispensing liquid from an inverted container having a depending neck defining an opening into a dischargeable reservoir open at its upper end and housed within a cabinet, comprising, in combination,

mounting means adapted to fit on the upper portion of said cabinet and defining an annular ring for supporting said inverted container thereon, said mounting means also defining a tapered entry portion extending downwardly and inwardly from said annular ring for receiving said inverted container neck therein, said entry portion having a lower end and a length greater than that of said container neck when said inverted container is supported on said annular ring,

means coupled to said lower end of said entry portion for sealingly closing said open upper end of

said reservoir and for supporting an upstanding feed tube dimensioned to penetrate into said container neck to provide a hygienic flow path for delivering liquid from said inverted container into said reservoir.

20. A system as defined in claim 19 wherein said means for supporting said feed tube includes a substantially annular diaphragm element coupled to said lower end of said entry portion of said mounting means.

21. A system as defined in claim 20 wherein said diaphragm element carries a flexible peripheral member for sealingly engaging and closing said open upper end of said reservoir.

22. A system as defined in claim 19 wherein said coupling means is detachably connected to said lower end of said entry portion to permit ready removal therefrom.

23. A system as defined in claim 20 wherein said diaphragm element is formed with quick-disconnect means for coupling said diaphragm element to said lower end of said entry portion.

24. A system as defined in claim 23 wherein said quick disconnect means includes cooperating bayonet-type fittings on said diaphragm and said lower end of said entry portion.

25. A system as defined in claim 19 wherein said coupling means is provided with an aperture therein outboard of said lower end of said entry

portion for admitting air into said reservoir as liquid is discharged therefrom.

26. A system as defined in claim 25 including air filter means connected to said aperture for filtering the air admitted into said reservoir.

27. A system as defined in claim 26 wherein said mounting means includes a portion adapted to be raised above said cabinet and said filter means is disposed under said raised portion.

28. A system as defined in claim 19 wherein said mounting means includes a portion adapted to be raised above said cabinet by downwardly extending side walls and includes internal ribs interconnecting said side walls and said tapered entry portion.

29. A system as defined in claim 19 wherein said liquid container is provided with a cap at least partially surrounding said neck and having an internal recess including a sleeve portion and sealing plug portion connected thereto and said upstanding feed tube is disposed for entry into said recess to separate said plug from said sleeve when said container is inverted and lowered onto said support ring.

30. A system as defined in claim 29 wherein said feed tube includes an internal bore and a radial inlet communicating therewith, said inlet being spaced from the tip end of said feed tube by a distance greater than the internal depth of said plug portion of said recess.

31. A system as defined in claim 29 wherein said plug is formed with internal gripping means therein and said feed tube is formed with complementary external gripping means for securing said plug on said feed tube when said feed tube is inserted in said recess and said frangible connection is broken.

32. A system as defined in claim 31 wherein said internal gripping means includes a radially inwardly projecting annular lip formed on said plug and said external gripping means includes an annular groove formed in the tip portion of said feed tube.

33. A system as defined in claim 29 wherein said plug is dimensioned to sealingly fit within said sleeve when said inverted container is lifted off said support ring and said feed tube is withdrawn from said recess.

1/4

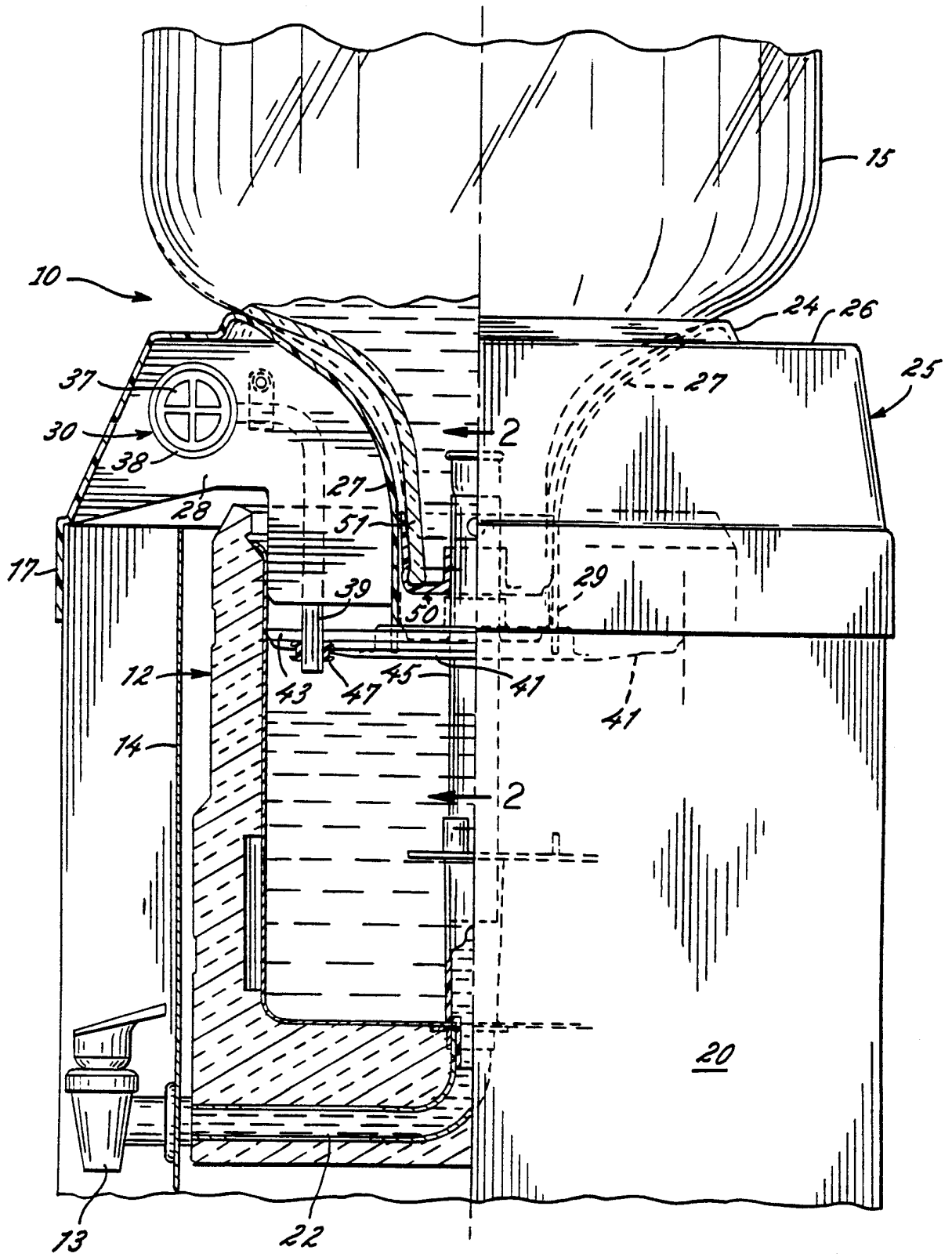

FIG. 1

2/4

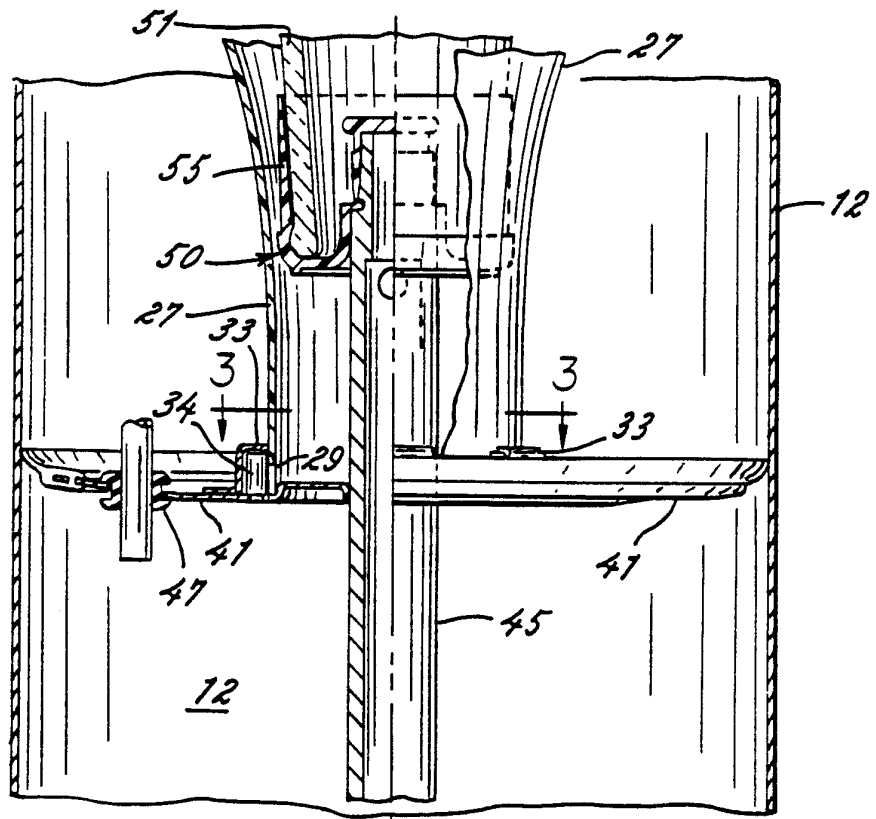

FIG. 2

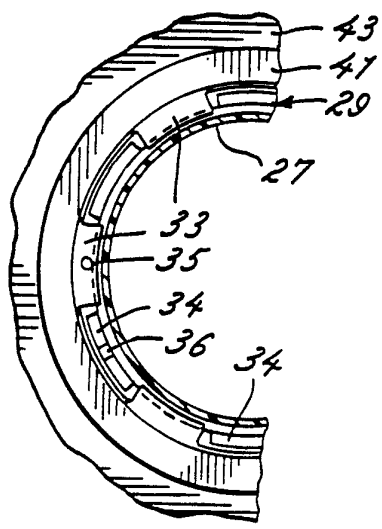

FIG. 3a

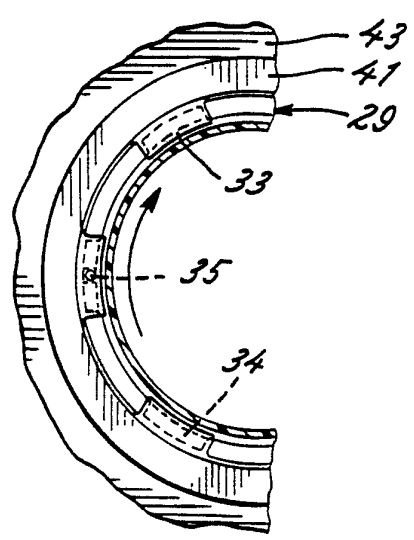
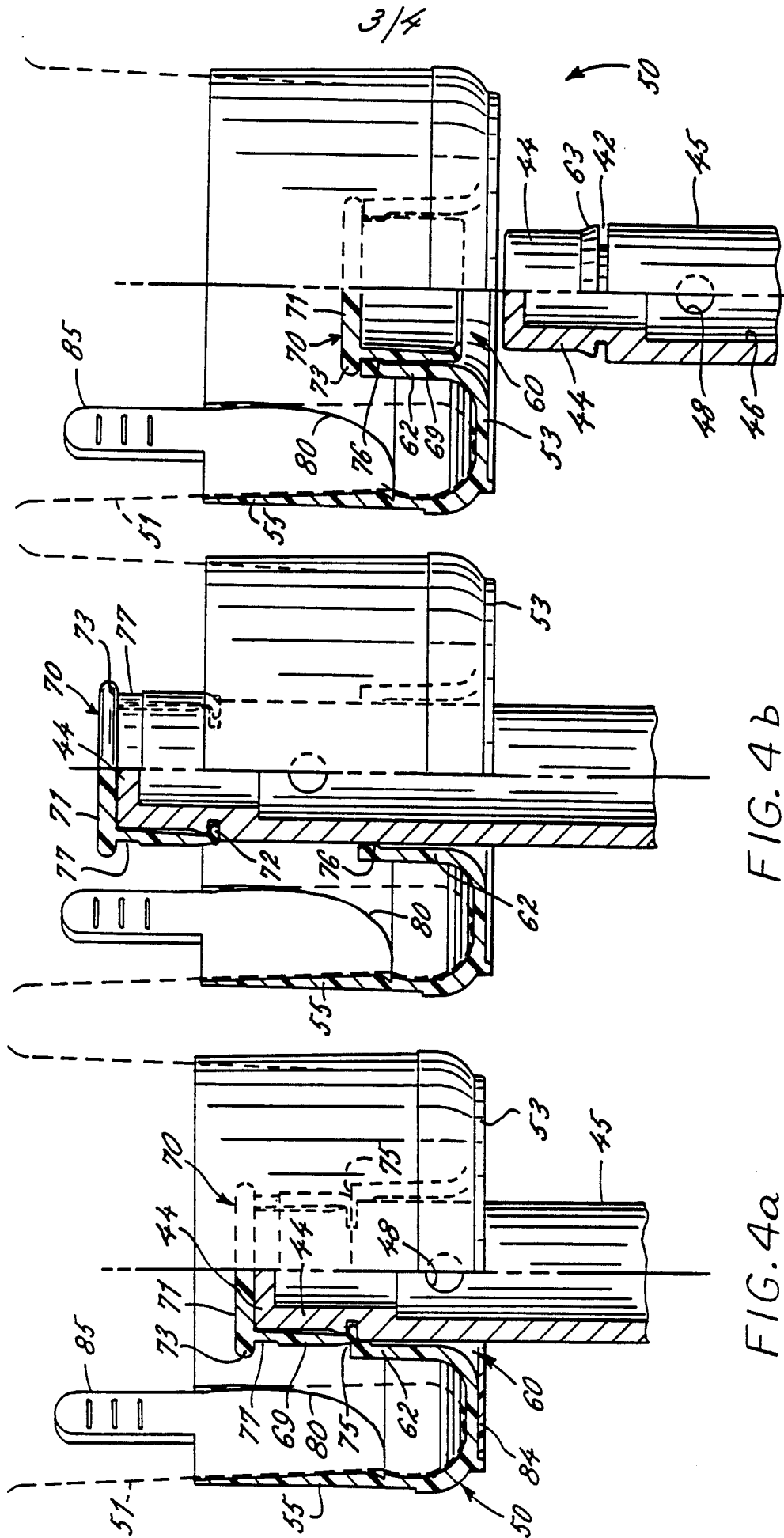

FIG. 3b



F/4

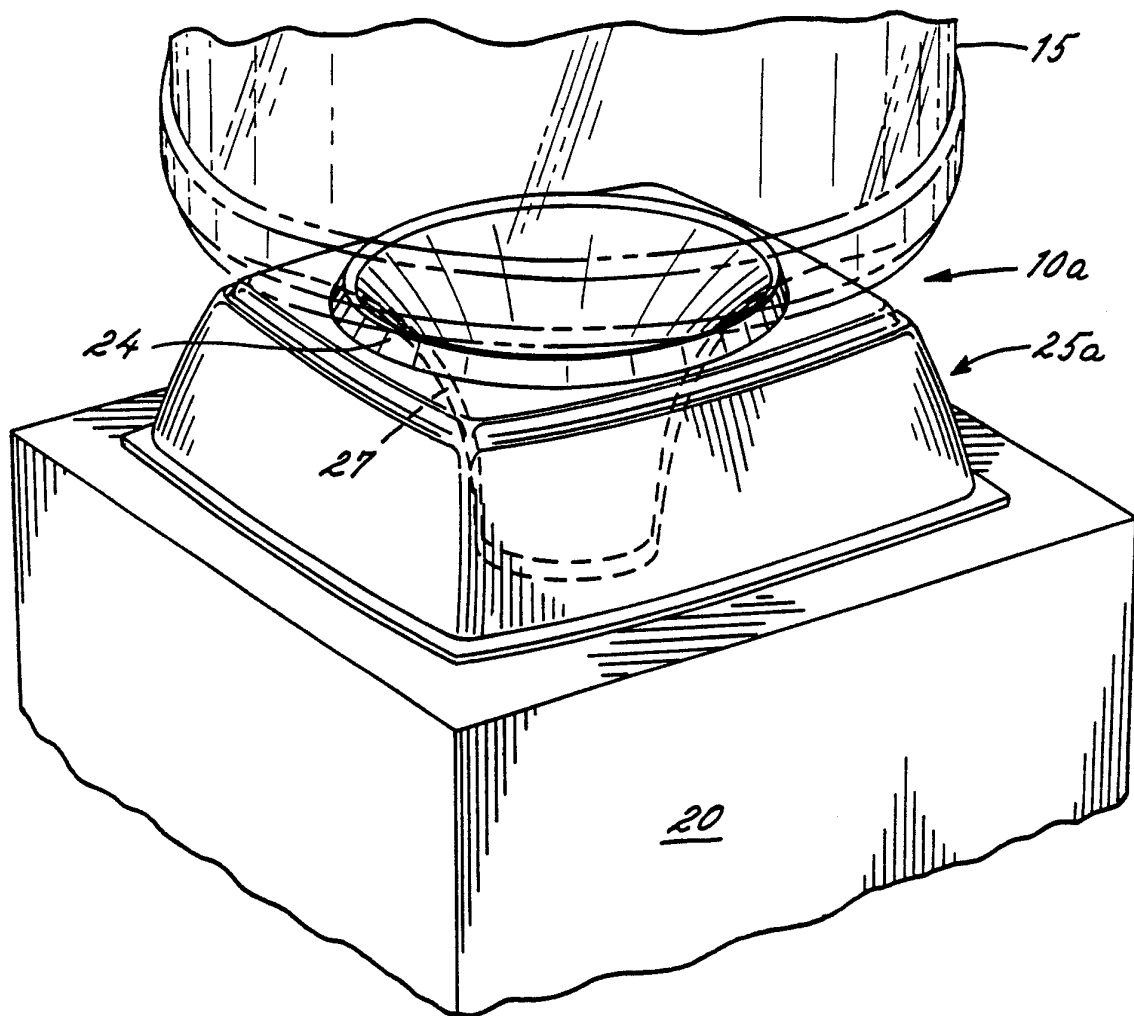

FIG. 5

INTERNATIONAL SEARCH REPORT

International Application No. PCT/US89/04465

I. CLASSIFICATION OF SUBJECT MATTER (if several classification symbols apply, indicate all) ⁶

According to International Patent Classification (IPC) or to both National Classification and IPC

IPC(4): B65B 3/06

II. FIELDS SEARCHED

Minimum Documentation Searched ⁷

Classification System	Classification Symbols
U.S. C1	141/18, 285, 319-322, 330-332, 348-350, 363-366

Documentation Searched other than Minimum Documentation
to the Extent that such Documents are Included in the Fields Searched ⁸

III. DOCUMENTS CONSIDERED TO BE RELEVANT ⁹

Category [*]	Citation of Document, ¹¹ with indication, where appropriate, of the relevant passages ¹²	Relevant to Claim No. ¹³
Y	US,A, Re.32,354 (SAVAGE) 17 Feb., 1987 See entire document	1-33
Y	US,A, 4,699,188 (BAKER et al.) 13 Oct., 1987 See entire document	1-33
Y	US,A, 4,597,423 (CHENOT) 1 July, 1986 See entire document	19-33
Y	US,A, 2,811,272 (LAWLOR) 29 Oct., 1957 See entire document	19-33
Y	US,A, 4,239,130 (ALTADONNA) 16 Dec., 1980 See entire document	23-24
Y,P	US,A, 4,834,267 (SCHROER et al.) 30 May, 1989 See entire document	1-33
Y,P	US,A, 4,846,236 (DERUNTZ) 11 July, 1989 See entire document	19-33
Y	US,A, 4,717,051 (LECLERC) 5 Jan., 1988 See entire document	1-18
Y	US,A, 1,976,007 (CULLEN et al.) 9 Oct., 1934 See entire document	19-33
Y	US,A, 4,267,945 (MAYNARD, JR.) 19 May, 1981 See entire document	19-33

^{*} Special categories of cited documents: ¹⁰

"A" document defining the general state of the art which is not considered to be of particular relevance

"E" earlier document but published on or after the international filing date

"L" document which may throw doubts on priority claim(s) or which is cited to establish the publication date of another citation or other special reason (as specified)

"O" document referring to an oral disclosure, use, exhibition or other means

"P" document published prior to the international filing date but later than the priority date claimed

"T" later document published after the international filing date or priority date and not in conflict with the application but cited to understand the principle or theory underlying the invention

"X" document of particular relevance; the claimed invention cannot be considered novel or cannot be considered to involve an inventive step

"Y" document of particular relevance; the claimed invention cannot be considered to involve an inventive step when the document is combined with one or more other such documents, such combination being obvious to a person skilled in the art.

"&" document member of the same patent family

IV. CERTIFICATION

Date of the Actual Completion of the International Search

30 November 1989

Date of Mailing of this International Search Report

21 DEC 1989

International Searching Authority

ISA/US

Signature of Authorized Officer

J. Casimer Jacyna
J. Casimer Jacyna