

(12) **EUROPEAN PATENT APPLICATION**

(21) Application number: **87307911.5**

(51) Int. Cl.4: **E05B 33/00**

(22) Date of filing: **08.09.87**

(30) Priority: **13.09.86 GB 8622120**

(43) Date of publication of application:
23.03.88 Bulletin 88/12

(84) Designated Contracting States:
BE DE FR IT NL

(71) Applicant: **Chubb & Son's Lock and Safe Company Limited**
Manor House Manor Lane
Feltham Middlesex, TW13 4JQ(GB)

(72) Inventor: **White, Malcolm John**
28 Birchwood Road Parkside
Lichfield Staffordshire(GB)

(74) Representative: **Obee, Robert William**
Racal Group Services Ltd. Group Legal
Department Richmond Court 309 Fleet Road
Fleet, Hants. GU13 8BU(GB)

(54) **Locking mechanisms.**

(57) The mechanism for locking the main boltwork of a safe or vault door includes a lock having a bolt 1 with a pivoted drop-arm 3 engageable in the slot 10 of a rotatable drive disc 6. For enabling and disabling the coupling of the arm 3 to the disc 6 there is an electromechanical actuator 12. This comprises a magnetisable element 11 pivoted within a coil 13 and a passing between the poles of a permanent magnet 14. Reverse pulses of current through the coil 13 therefore cause the element 11 to flip between two stable positions. In the locking position of the actuator (Fig 1) the element 11 prevents the arm 3 from dropping into the slot 10. When a correct code is entered into an associated user-authentication device the coil 13 is pulsed to flip the element 11 clear of the arm 3. The disc 6 can therefore be turned to pick up the head of the arm 3 (Fig 2) and withdraw the bolt (Fig 3).

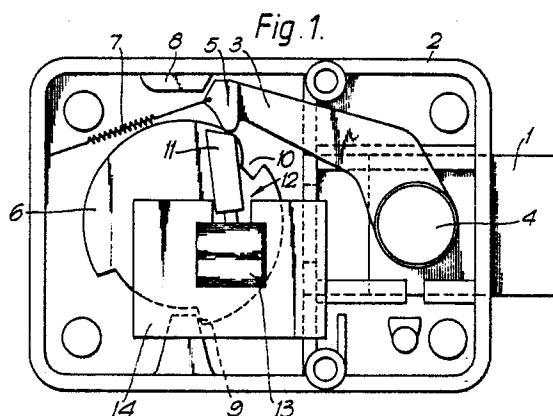

EP 0 260 860 A1

Locking Mechanisms

The present invention relates to locking mechanisms. More particularly, though not exclusively, the invention seeks to provide an electromechanical locking mechanism which can be used in an electronically-controlled code-recognition lock for safes and the like security enclosures, which is mechanically simple and highly reliable in operation, and operable with minimal power consumption.

In one aspect the invention accordingly resides in a locking mechanism comprising a bolt or other such locking member movable between locking and unlocking positions; a manually or otherwise operable control member adapted to be coupled to the locking member for moving the latter between its locking and unlocking positions; and an electromechanical actuator arranged for selectively disabling or enabling the coupling of the control member to the locking member such as to move the latter from its locking to its unlocking position.

In a preferred embodiment, said actuator comprises first magnetic means including an element of magnetisable material and means for applying a pulsed magnetising field thereto, the said magnetisable material being such that said element is capable of repeated reversals of its magnetic polarity in response to the application thereto of magnetising pulses of reverse senses and is capable of remaining magnetised with the last-induced polarity between such pulses; and second magnetic means for providing a predetermined magnetic field to interact with the remanent magnetism of said element; whereby said actuator is biased by the magnetic interaction between said element and said second magnetic means to move to a first or a second position respectively to disable or enable said coupling of the control member to the locking member, in dependence upon the sense of the last-applied said pulse.

Typically, the magnetisable element in the aforesaid actuator may be in the form of a bar pivoted at one end and surrounded by a coil through which the magnetising pulses are applied, while the aforesaid second magnetic means comprise a permanent magnet defining opposed poles between which the opposite end of the bar lies, whereby the bar is influenced at any instant to pivot towards one or other of the permanent magnet poles in dependence upon the sense of the last-induced polarity of the bar. The said opposite end of the bar, or a member carried by it, can therefore serve as an abutment to block or free the aforesaid coupling of the control member to the locking member in the two respective pivotal positions of the bar.

In use of an actuator as defined above, since only a pulse of magnetising energy is required to reverse and retain the polarity of the magnetisable element little power is consumed in switching the actuator between its two states, as distinct from e.g. the conventional solenoid which consumes power for the whole of the time that it is in the "energised" state. Furthermore, by remaining magnetised with the last-induced polarity between pulses the magnetisable element in effect "remembers" its most recent command so that, for example, if the actuator is blocked or otherwise restrained from moving into its position appropriate to that command at the instant when the corresponding pulse is given, it will nevertheless move into and remain in the correct position under the remanent magnetic influence as soon as the aforesaid restraint is removed, without having to be pulsed again at that time. The particular advantages of this characteristic in the context of an actuator for use in a preferred safe lock mechanism will appear from the ensuing description.

In a preferred embodiment of the aforesaid mechanism the control member is in the form of a rotatable disc or sector having a coupling notch in its periphery, and an arm is articulated to the locking member having a head adapted to engage in said notch; in the locking position of the mechanism the head of said arm lying in a position out of driving engagement with said notch and preferably facing an abutment to resist forced movement of the locking member towards its unlocking position; and said actuator serving in a first position to block movement of said head into driving engagement with said notch such as to enable the control member to move the locking member to its unlocking position.

These and other aspects of the present invention will now be more particularly described, by way of example, with reference to the accompanying drawings, in which:

Figure 1 shows the mechanism of an electronically-controlled safe lock, with its cap removed, in the locked condition;

Figure 2 is a similar view of the mechanism of Figure 1, in the condition in which it has been freed for unlocking;

Figure 3 is a similar view of the mechanism of Figures 1 and 2, in the unlocked condition; and

Figure 4 is a sectional view, to an enlarged scale, through the electromechanical actuator of the mechanism of Figures 1 to 3.

The lock shown in the drawings is intended principally for use in locking the main boltwork of a safe or vault door, and its layout and dimensions are chosen so that the unit may be interchangeable with known keyless combination locks, such as that marketed by the present applicants under the designation 7L08. It has a bolt 1 which can be extended and retracted from the case 2 and to which a drop-arm 3 is pivoted at 4. The arm 3 has a laterally-extended head 5 at its end opposite to its connection with the bolt, which in the normal locked condition of the mechanism illustrated in Figure 1 lies on the periphery of a rotatable disc 6, onto which it is drawn by a spring schematically indicated at 7. In this condition the head 5 faces a fixed abutment 8 in the lock case to resist forced retraction of the bolt 1.

The disc 6 is freely rotatable by hand through the agency of an external knob or handle (not shown), within limits set by a stop 9A, but is normally held lightly in the rest position shown in Figure 1 by means of a detent spring (not shown). It has a notch 10 in its periphery which, when the disc is turned anti-clockwise (in the sense of the drawing) away from its rest position underlies the head 5 of the drop-arm, and into which the head is biased to engage by the spring 7 so as to establish a drive connection between the disc 6 and bolt 5. Normally, however, the head 5 is blocked from moving into full engagement with the notch 10 and free of the abutment 8 by the presence of the actuating member 11 of a bistable electromechanical actuator 12. The actuator 12 is similar to the actuators shown in our copending United Kingdom patent application No. 2142374, comprising a magnetising coil 13 within which the actuating member 11 is pivoted, and a rectangular horseshoe permanent magnet 14 surrounding the coil 13, with the actuating member extending through the gap between the poles of the permanent magnet. That part of the actuating member 11 which extends within the coil 13 and between the associated permanent magnet poles is made from a magnetisable material having a low energy requirement for reversing its magnetic polarity coupled with a high remanence, such as a heat-treated element of the cobalt-iron-vanadium alloy marketed by Telcon Metals Limited under the name "Chromindur".

An example of the construction of an actuator 12 for use in this lock mechanism is shown in Figure 4. A bar 11A (which may be laminated) of Chromindur is fitted at one end with a plastics cap 11B by which it is pivotally borne in a pair of recesses 13B formed inside the coil bobbin 13A. The bar 11A extends out of the bobbin 13A to lie between the poles P1 and P2 of the associated field magnet 14 and its upper end is fitted with a plastics tip piece 11C. The actuator is assembled

by passing the Chromindur bar 11A with its cap 11B through the bottom of the coil bobbin 13A and snapping on the tip piece 11C. The coil is then assembled to the magnet 14 which retains the actuating member against ejection through the bottom of the bobbin.

The actuating member 11 can be flipped between two positions (as indicated by comparing its positions in Figures 1 and 2) in response to pulses of electricity passed through the associated coil 13 in opposite directions. For example, if it is assumed that the magnet pole P1 is a North and P2 a South, then if an electrical pulse is sent through the associated coil 13 in the direction such as to induce a North pole at the bottom end of the Chromindur element 11A within the coil and a South pole at the top end of that element between the poles P1 and P2, then the element will be attracted by pole P1 and repelled by pole P2 so as to pivot the actuating member into the position in which it is shown in Figure 1, being its locking position. The remanence of the element 11A is sufficient to keep the actuating member in that position until an electrical pulse is sent through the coil 13 in the opposite direction, whereupon the induced polarity of the element 11A is reversed so that its end between the poles P1 and P2 now becomes a North, and it will be influenced oppositely by the permanent magnet poles to pivot the actuating member into the position in which it is shown in Figure 2, being its release position.

In use, magnetising pulses are supplied to the coil 13 from an electronic control circuit (not shown) associated with a code-input or recognition device such as a numeric keypad, card-reader, biometric sensor or the like, so that the coil 13 is pulsed to move the actuating member out of its Figure 1 position and into its Figure 2 position only when a correct code or other indication of the user's authority to operate the lock has been entered. A timing circuit may also be included to restrict possible operation of the actuator to its release position only to specified periods of the day.

Assuming that the actuator has been flipped to its release position, the disc 6 can now be turned to pick up the drop-arm 3 as shown in Figure 2. Turning the disc further anti-clockwise (in the sense of the drawing) thereafter retracts the bolt 1 to the Figure 3 position, through the coupling established between the drop-arm head 5 and notch 10.

The operation of the control circuit may provide for an unlocking "window" of limited duration following operation of the actuator 12 to its release position, after which the coil 13 will be automatically pulsed again to return the member 11 to its locking position (shown in dotted line in Figure 3), or a separate locking pulse may be given under

user control. The bolt 1 can be thrown out again, (either before or after the actuator has been flipped back to its locking position), by turning the disc 6 clockwise to drive the drop-arm 3 rightwards through the engagement of its head 5 in the notch 10. In doing so, if the actuator has already been flipped back to its locking position the head 5 will come up against the side of the actuating member 11 and displace it temporarily back to its release position, the mechanism passing through a condition equivalent to that shown in Figure 2 at this point. From this condition, continued clockwise rotation of the disc 6 will serve to throw out the drop-arm head 5 from the notch 10 through the action of the cam surfaces 5A and 10A of these elements, so that the disc and drop-arm return to the relationship shown in Figure 1. If the locking pulse has already been given, as soon as the head 5 rises clear of the end of the actuating member 11 the latter will flip back to its locking position by the interaction of its remanent magnetism with the field of the permanent magnet 14. Otherwise, it will move back to its locking position when the subsequent locking pulse is given. It will be seen that the actuating member 11 is not loaded by the drop-arm in the normal locked condition of the mechanism.

It has been mentioned that during the time between pulses through the actuator coil 13, the last-induced polarity of the magnetisable element 11A is retained, so that this polarity serves effectively as a "memory" of the most recent command signal, i.e. "lock" or "release". The potential importance of this characteristic during the bolt-throwing sequence of the illustrated lock has already been explained. It is also of importance in the following circumstances. That is to say it may occur that at the time when a "release" command is given a user may have already turned the disc 6 from the Figure 1 position to align the notch 10 with the head 5, so that the drop-arm is resting on the actuating member 11 and the latter is prevented from moving at the instant when the coil 13 is pulsed to reverse its polarity. However, the magnetic influence on the actuating member remains so that as soon thereafter as the disc 6 is turned again to lift the drop-arm slightly the actuator will flip over to its "release" position and the bolt 1 can be withdrawn, without any further energisation of the coil 13.

Claims

1. A locking mechanism comprising a bolt (1) or other such locking member movable between locking and unlocking positions; and a manually or otherwise operable control member (6) adapted to

be coupled to the locking member (1) for moving the latter between its locking and unlocking positions; characterised by an electromechanical actuator (12) arranged for selectively disabling or enabling the coupling of the control member (6) to the locking member (1) such as to move the latter (1) from its locking to its unlocking position.

2. A mechanism according to claim 1 wherein said actuator (12) comprised first magnetic means including an element (11A) of magnetisable material and means (13) for applying a pulsed magnetising field thereto, the said magnetisable material being such that said element (11A) is capable of repeated reversals of its magnetic polarity in response to the application thereto of magnetising pulses of reverse senses and is capable of remaining magnetised with the last-induced polarity between such pulses; and second magnetic means (14) for providing a predetermined magnetic field to interact with the remanent magnetism of said element (11A); whereby said actuator (12) is biased by the magnetic interaction between said element (11A) and said second magnetic means (14) to move to a first or a second position respectively to disable or enable said coupling of the control member (6) to the locking member (1), in dependence upon the sense of the last-applied said pulse.

3. A mechanism according to claim 2 wherein said magnetisable element is in the form of a bar (11A) pivoted at one end and surrounded by a coil (13) through which the magnetising pulses are applied, while the aforesaid second magnetic means comprise a permanent magnet (14) defining opposed poles (P1, P2) between which the opposite end of the bar (11A) lies, whereby the bar (11A) is influenced at any instant to pivot towards one or other of the permanent magnet poles (P1, P2) in dependence upon the sense of the last-induced polarity of the bar (11A).

4. A mechanism according to claim 3 wherein the opposite end of said bar (11A), or a member (11C) carried by it, serves as an abutment to block or free the aforesaid coupling of the control member (6) to the locking member (1) in the two respective pivotal positions of the bar (11A).

5. A mechanism according to any preceding claim wherein the control member is in the form of a rotatable disc (6) or sector having a coupling notch (10) in its periphery, and an arm (3) is articulated to the locking member (1) having a head (5) adapted to engage in said notch (10); in the locking position of the mechanism the head (5) of said arm (3) lying in a position out of driving engagement with said notch (10); and said actuator (12) serving in a first position to block movement of said head (5) into driving engagement with said

notch (10) such as to enable the control member (6) to move the locking member (1) to its unlocking position.

6. A mechanism according to claim 5 wherein in the locking position thereof the head (5) of said arm (3) faces an abutment (8) to resist forced movement of the locking member (1) towards its unlocking position.

5

10

15

20

25

30

35

40

45

50

55

5

Fig. 1.

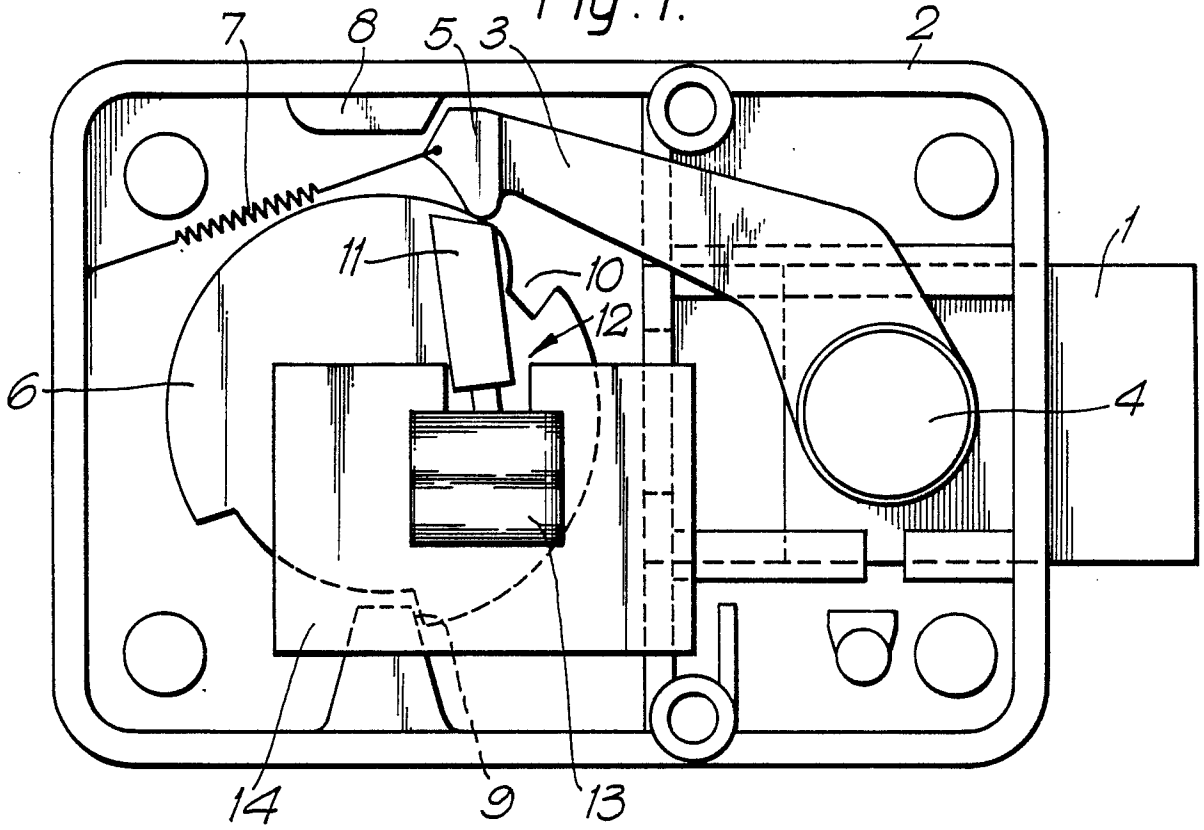

Fig. 2.

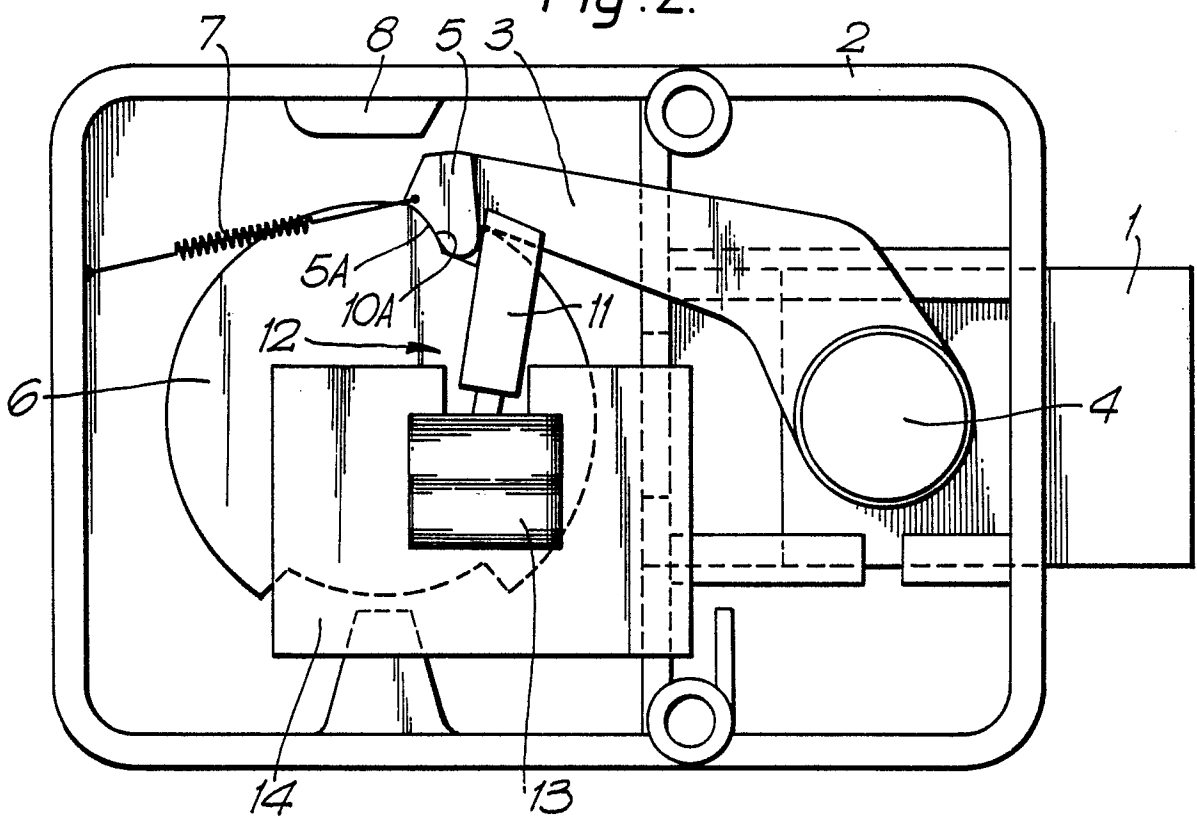

Fig. 3.

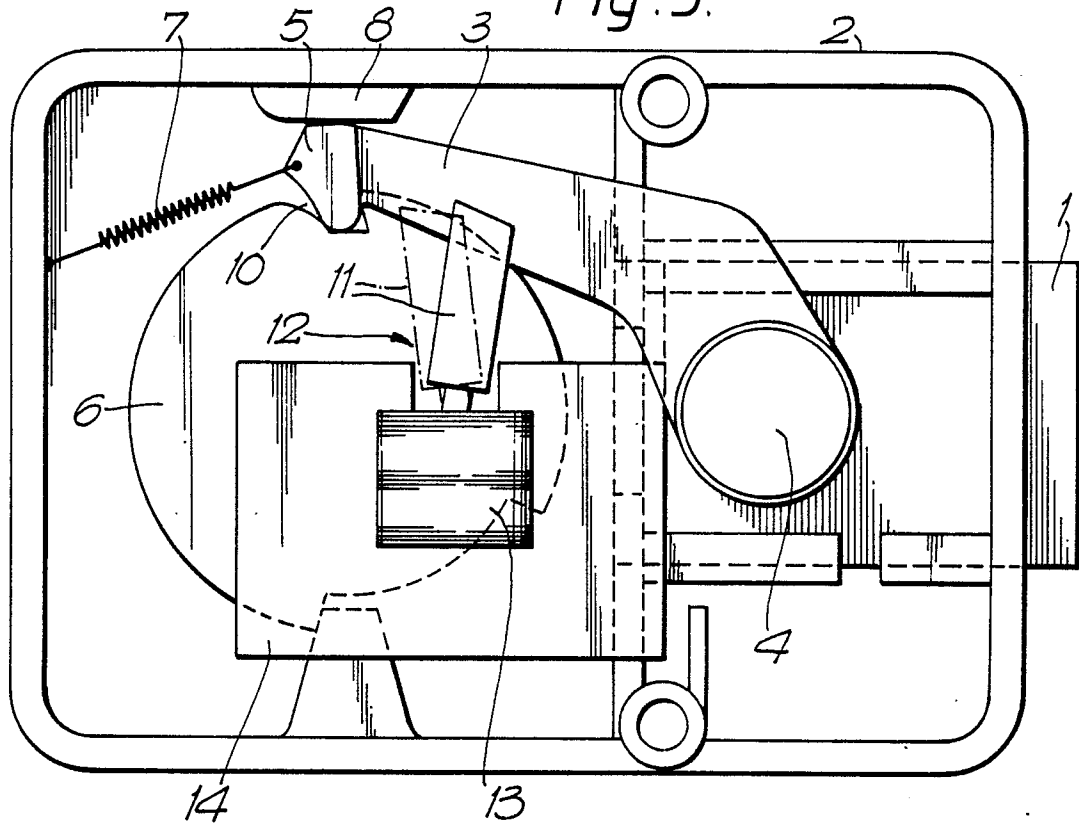
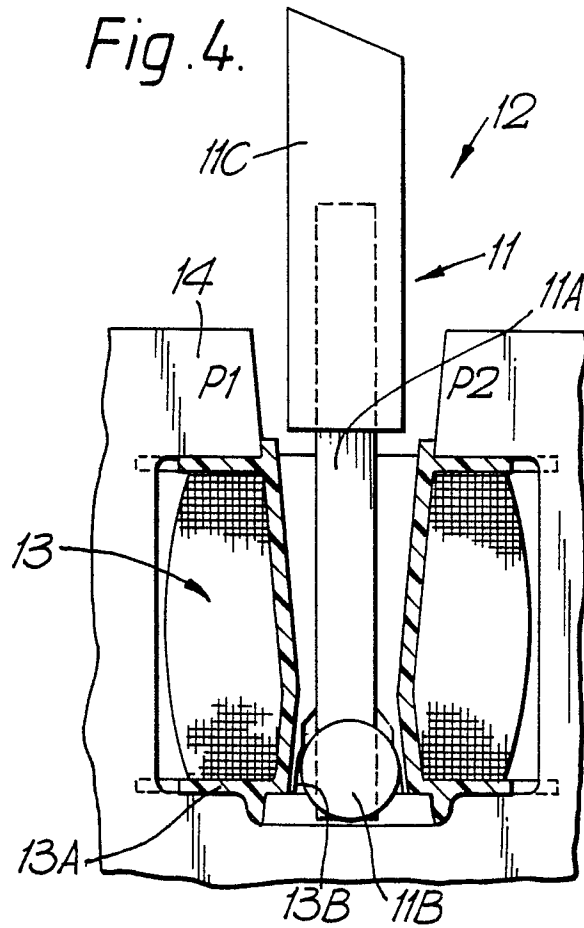

Fig. 4.





EP 87307911.5

DOCUMENTS CONSIDERED TO BE RELEVANT			EP 87307911.5
Category	Citation of document with indication, where appropriate, of relevant passages	Relevant to claim	CLASSIFICATION OF THE APPLICATION (Int. Cl. 4)
A	CH - A5 - 606 717 (FERTIGBAU- TECHNIK HANS STEURER) * Fig. 1-3; column 6 * --	1,5	E 05 B 33/00
A	FR - B1 - 2 225 601 (DAEMPA A/S) * Fig. 1-3; page 6 * ----	1,5,6	
			TECHNICAL FIELDS SEARCHED (Int. Cl. 4)
			E 05 B
The present search report has been drawn up for all claims			
Place of search VIENNA		Date of completion of the search 12-11-1987	Examiner CZASTKA
CATEGORY OF CITED DOCUMENTS X : particularly relevant if taken alone Y : particularly relevant if combined with another document of the same category A : technological background O : non-written disclosure P : intermediate document		T : theory or principle underlying the invention E : earlier patent document, but published on, or after the filing date D : document cited in the application L : document cited for other reasons & : member of the same patent family, corresponding document	