

No. 824,235.

PATENTED JUNE 26, 1906.

N. L. DAMON.  
MOLD FOR MAKING ARTIFICIAL STONE.

APPLICATION FILED JUNE 26, 1905.

2 SHEETS—SHEET 1.

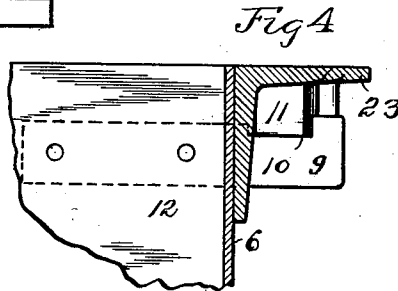
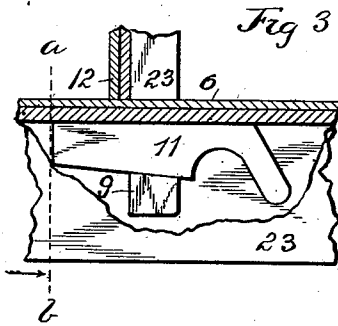
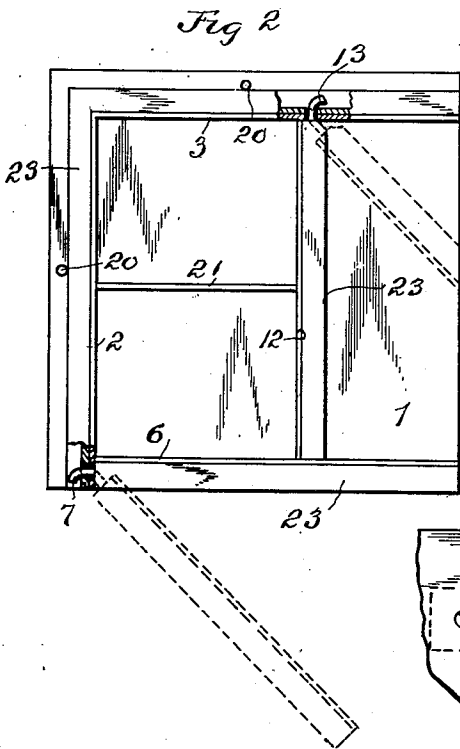
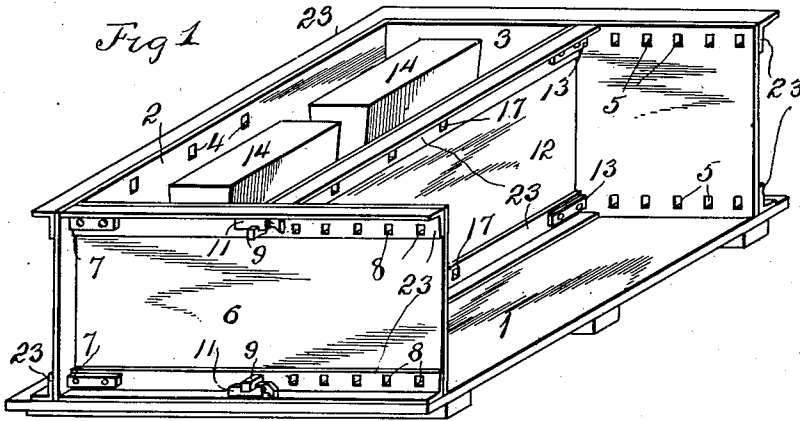

Witnesses:

*R. Hamilton*  
*R. H. House*

Inventor

*Nelson L. Damon*

By

*Warren D. House*

his Attorney

No. 824,235.

PATENTED JUNE 26, 1906.

N. L. DAMON.  
MOLD FOR MAKING ARTIFICIAL STONE.

APPLICATION FILED JUNE 26, 1905.

2 SHEETS—SHEET 2.

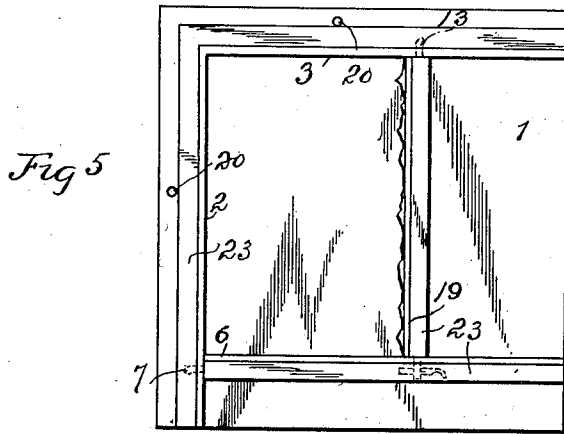

Fig 5

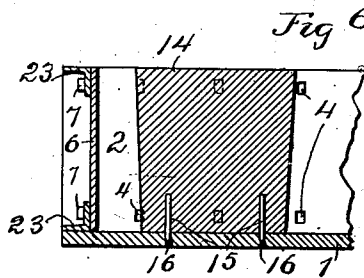

Fig 6

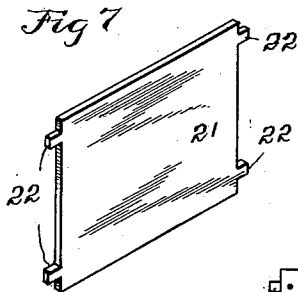

Fig 7

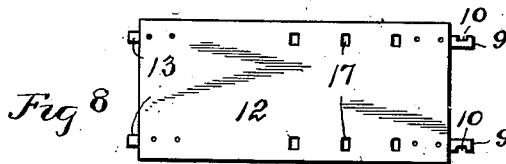

Fig 8



Fig 9



Fig 10

Witnesses  
*R. Hamilton.*  
*R. C. House*

Inventor  
*Nelson L. Damon*  
 By *Warren D. House*  
 his Attorney

# UNITED STATES PATENT OFFICE.

NELSON L. DAMON, OF CARTHAGE, MISSOURI.

## MOLD FOR MAKING ARTIFICIAL STONE.

No. 824,235.

Specification of Letters Patent.

Patented June 26, 1906.

Application filed June 26, 1905. Serial No. 267,016.

*To all whom it may concern:*

Be it known that I, NELSON L. DAMON, a citizen of the United States, residing at Carthage, in the county of Jasper and State of Missouri, have invented certain new and useful Improvements in Molds for Making Artificial Stone, of which the following is a specification.

My invention relates to improvements in molds for making artificial-stone blocks or columns.

The object of my invention is to provide a mold which may be adapted to form blocks or columns of different dimensions, means being provided by which the sides of the mold may be horizontally adjusted relative to each other, so as to produce blocks of different widths and lengths.

My invention is adapted to be used in the production of blocks or columns having plain or fancy faces.

The peculiarities of my invention are hereinafter fully described and claimed.

In the accompanying drawings, Figure 1 is a perspective view of the mold, the side member shown having a plain face. Fig. 2 is a top view of the mold shown in Fig. 1, the cores being removed and a dividing-plate shown. In this view the right-angled member is partly broken away to show the hooks of the side and end members. In this view the side and end members are shown in dotted lines as being partly removed. Fig. 3 is a horizontal sectional view of portions of the side and end members and showing the device for locking said members together. Fig. 4 is a vertical section taken on the dotted line *ab* of Fig. 3. Fig. 5 is a plan view of the mold, showing as a part thereof the side member having a rock face. Fig. 6 is a vertical sectional view of a portion of the mold, taken longitudinally and centrally through one of the cores. Fig. 7 is a perspective view of the dividing-plate. Fig. 8 is a side elevation of the plain side member. Figs. 9 and 10 represent, respectively, two side members of different lengths, each having a fancy or rock face.

Similar characters of reference denote similar parts.

1 denotes the ordinary supporting-plate, sometimes called the "pallet," upon which rest the sides of the mold. Upon the supporting-plate 1 is mounted a right-angled vertical member, the two arms 2 and 3 of which form, respectively, one side and one

end of the mold. The side arm 2 is provided with a longitudinally-arranged series of holes 4, disposed one row above the other. The end arm 3 is provided with two rows of holes 5, similarly arranged. The end member 6 comprises a vertical plate provided with two hooks 7, disposed at one end, one above the other, and adapted to enter, respectively, the holes in the upper and lower rows of the side arm 2. The member 6 is provided with two rows of holes 8, arranged longitudinally one row above the other and adapted to receive therein, respectively, two projections 9, each provided with a lateral notch 10. Two keys, preferably wedge form and denoted by 11, are adapted to be mounted upon the outer side of the member 6 in the notches 10, respectively. The projections 9 are at one end of a side member comprising a vertical longitudinally-arranged plate 12, the other end of which is provided with two hooks 13, adapted to enter, respectively, the holes 5 in the arm 3.

14 denotes two vertical rectangular downwardly-tapering cores adapted to be placed upon the plate 1 between the different members forming the sides of the mold. The lower end of each core 14 is provided with a plurality of vertical pins 15, adapted to be inserted in holes 16, provided in the plate 1. The side member 12 is provided with two rows of holes 17, disposed in longitudinal rows, one row above the other.

18 and 19 denote, respectively, two side members, one longer than the other, each provided with a rock-face and each having at one end the projections 9 and at the other end the hooks 13. The plates 12, 18, and 19 are interchangeable. When one of these is used, the end member 6 has the hooks 7 inserted in those holes 4 which are disposed to correspond with the length of the side member used. In assembling the parts the cores 14 are properly placed on the plate 1. The side member 12, 18, or 19, as the case may be, has the hooks 13 inserted in these holes 5, suitable for positioning the side member for the width of stone desired. The end member 6 is then placed on the plate 1 with its hooks 7 in the proper holes 4 and then swung to a position in which the projections 9 will enter the proper holes 8, after which the keys 11 are inserted in the notches 10, thus rigidly locking the side and end members together. The cementitious material is then tamped in the mold around the cores 14, after which the

cores and keys 11 are removed, following which the side and end members are disengaged from each other and from the right-angled member. The right-angled member  
 5 may then be withdrawn from the plate 1, after which the plate, with the molded block thereon, may be removed and the cores, together with the right-angled member and the side and end members, may be assembled  
 10 upon another supporting-plate 1 and the operation repeated.

In column construction the plate 1 is dispensed with, the side and end members of the mold being mounted upon the top of the  
 15 block previously formed. To prevent side movement of the mold members on the plate 1, vertical pins 20, two of which are shown in Fig. 2, may be inserted in suitably-disposed holes in the plate 1 and outside the mold  
 20 members.

When it is desired to transversely divide the block, I employ a vertical dividing-plate 21, movable to different positions between the side arm 2 and the side member 12 and  
 25 toward and from the end arm 3. The dividing-plate 21 is provided with four projections 22, disposed two at each end, one above the other, and adapted to enter similarly-located holes 4 and 17 in the side arm 2 and  
 30 side member 12, respectively. In Fig. 2 the dividing-plate 21 is shown positioned so as to divide the block in two equal parts.

In order to reinforce them, the end and side members 6 and 12 and the two arms of the right-angled member are preferably provided upon their outer sides and adjacent  
 35 their upper and lower edges, respectively, with longitudinally-disposed angle-bars 23, rigidly secured to the plates forming the bodies of said members. The perforations  
 40 4, 5, 8, and 17 extend transversely through said angle-bars.

Various modifications of my invention may be resorted to without departing from  
 45 its spirit.

Having thus described my invention, what I claim, and desire to secure by Letters Patent, is—

1. In a mold, the combination with a right-angled member two arms of which form  
 50 respectively one end and one side of the mold one arm having two longitudinally-arranged rows of perforations, one row being disposed above the other, the other arm having two  
 55 holes disposed one above the other, of an end member provided at one end with two hooks adapted to be inserted in said two holes and having two rows of holes arranged one row above the other, a side member provided at  
 60 one end with two hooks adapted to engage respectively the holes in the upper and lower rows of the right-angled member and provided at the other end with two projections adapted to be inserted respectively in the  
 65 holes of the upper and lower rows of the end

member, and releasable means for locking the side and end members together.

2. In a mold, the combination with a right-angled member, the two arms of which form  
 70 respectively one end and one side of the mold, one arm having two longitudinally-arranged rows of holes disposed one row above the other, the other arm having two holes disposed one above the other, of an end member  
 75 having two hooks adapted to enter said two holes and provided with two rows of holes disposed one row above the other, a side member having at one end two hooks adapted to enter respectively the holes in the two  
 80 rows of the right-angled member and provided at its other end with two projections adapted to enter respectively the holes in the upper and lower rows in the end member, each projection having a notch, and two  
 85 wedges adapted to be inserted respectively in the notches of said projections, and disposed upon the outer side of the end member.

3. In a mold, the combination with a right-angled member, two arms of which form  
 90 respectively one end and one side of the mold, each arm having two longitudinally-arranged rows of holes disposed one row above the other, an end member having two hooks for engaging respectively the holes in the upper  
 95 and lower rows of the side arm and provided with two longitudinally-arranged rows of holes disposed one row above the other, a side member having two hooks for engaging the holes in the upper and lower rows respectively  
 100 of the end arm and provided with two projections adapted to enter respectively the holes in the upper and lower rows of the end member, and two wedges adapted to be mounted respectively between the projections of the side member and the outer side  
 105 of the end member.

4. In a mold, the combination with a right-angled member, the two arms of which form  
 110 respectively one end and one side of the mold, of an end member hinged at one end to the side arm, a side member hinged at one end to the end arm and provided with means for releasably engaging the end arm, and a vertical  
 115 dividing-plate adjustable toward and from the end arm and provided with means for being secured at its ends to the side arm and side member respectively.

5. In a mold, the combination with a right-angled member, the two arms of which form  
 120 respectively one end and one side of the mold, each arm having two holes disposed one above the other, of an end member having two hooks for engaging respectively the holes in one arm, said end member having two  
 125 holes disposed one above the other, a side member having two hooks for engaging respectively the holes in the end arm and provided with two projections for insertion through the holes in the end member, two  
 130 keys for engaging respectively said two pro-

jections and the outer side of the end member, and a vertical dividing-plate adjustable toward and from the end arm and provided at its ends with means for being secured to the side arm and side member respectively.

5 6. In a mold, the combination with a right-angled member, the two arms of which form respectively one end and one side of the mold, the end arm having two holes disposed one  
10 above the other, and the side arm having two rows of holes disposed longitudinally one above the other, of an end member having two hooks for engaging respectively the holes in the upper and lower rows of the side arm,  
15 the end member having two holes disposed one above the other, a side member having two hooks for engaging the holes in the end arm and provided with two longitudinally-arranged rows of holes disposed one row  
20 above the other and having also two projections for insertion through the holes in the end member, two keys for engaging respectively said projections and the outer side of the end member, and a vertical dividing-  
25 plate having four projections disposed two at each end, the projections on the dividing-plate being adapted to enter respectively the holes in the upper and lower rows of the side arm and side member.

30 7. In a mold, the combination with a right-angled member, the two arms of which form respectively, one end and one side of the mold, the end arm having two longitudinally-arranged rows of holes disposed one row above  
35 the other, the side arm having two rows of holes arranged longitudinally one row above the other, of an end member having at one end two hooks for engaging respectively the

holes in the upper and lower rows in the side arm and having also two rows of holes disposed longitudinally one row above the other,  
40 a side member having at one end two hooks for insertion respectively in the holes in the upper and lower rows of the end arm, and having at its other end two projections for  
45 insertion respectively through the holes in the upper and lower rows of the end member, two locking-keys for engaging respectively said two projections and the outer side of the end member, and a horizontal plate  
50 for supporting said members.

8. In a mold, the combination with a right-angled member, two arms of which form respectively one end and one side of the mold, each arm having two longitudinally-arranged  
55 rows of holes disposed one row above the other, of an end plate having at one end two hooks for engaging the holes of the upper and lower rows in the side arm, the end plate having two longitudinally-arranged rows of holes  
60 disposed one row above the other, a side member having two hooks for insertion in the holes of the upper and lower rows of the end arm and provided also with two end projections and having a transverse notch, said end  
65 projections being adapted to enter the holes in the upper and lower rows of the end member, and two wedge-form keys mounted on the outside of the end member in the notches respectively of the said two projections.

In testimony whereof I affix my signature in presence of two witnesses.

NELSON L. DAMON.

Witnesses:

E. L. WILLIAMS,  
D. N. DAMON.