



(51) International Patent Classification:

A61F 13/537 (2006.01) B32B 5/04 (2006.01)  
A61F 13/472 (2006.01) B32B 5/24 (2006.01)  
A61F 13/475 (2006.01) B32B 37/14 (2006.01)  
B32B 3/10 (2006.01)

(21) International Application Number:

PCT/SE2015/050671

(22) International Filing Date:

10 June 2015 (10.06.2015)

(25) Filing Language:

English

(26) Publication Language:

English

(71) Applicant: SCA HYGIENE PRODUCTS AB [SE/SE];  
S-405 03 Göteborg (SE).

(72) Inventors: JÖNEGREN, Åsa; c/o SCA Hygiene Products  
AB, S-405 03 Göteborg (SE). KALENTUN, Pia; c/o SCA  
Hygiene Products AB, S-405 03 Göteborg (SE). EDRUD,  
Susanna; c/o SCA Hygiene Products AB, S-405 03 Göte-  
borg (SE). HANSSON, Morgan; c/o SCA Hygiene  
Products AB, S-405 03 Göteborg (SE). ANDERSSON,  
Susanne; c/o SCA Hygiene Products AB, S-405 03 Göte-  
borg (SE).

(74) Agent: SCA HYGIENE PRODUCTS AB; SCA IP De-  
partment, 405 03 Göteborg (SE).

(81) Designated States (unless otherwise indicated, for every

kind of national protection available): AE, AG, AL, AM,  
AO, AT, AU, AZ, BA, BB, BG, BH, BN, BR, BW, BY,  
BZ, CA, CH, CL, CN, CO, CR, CU, CZ, DE, DK, DM,  
DO, DZ, EC, EE, EG, ES, FI, GB, GD, GE, GH, GM, GT,  
HN, HR, HU, ID, IL, IN, IR, IS, JP, KE, KG, KN, KP, KR,  
KZ, LA, LC, LK, LR, LS, LU, LY, MA, MD, ME, MG,  
MK, MN, MW, MX, MY, MZ, NA, NG, NI, NO, NZ, OM,  
PA, PE, PG, PH, PL, PT, QA, RO, RS, RU, RW, SA, SC,  
SD, SE, SG, SK, SL, SM, ST, SV, SY, TH, TJ, TM, TN,  
TR, TT, TZ, UA, UG, US, UZ, VC, VN, ZA, ZM, ZW.

(84) Designated States (unless otherwise indicated, for every

kind of regional protection available): ARIPO (BW, GH,  
GM, KE, LR, LS, MW, MZ, NA, RW, SD, SL, ST, SZ,  
TZ, UG, ZM, ZW), Eurasian (AM, AZ, BY, KG, KZ, RU,  
TJ, TM), European (AL, AT, BE, BG, CH, CY, CZ, DE,  
DK, EE, ES, FI, FR, GB, GR, HR, HU, IE, IS, IT, LT, LU,  
LV, MC, MK, MT, NL, NO, PL, PT, RO, RS, SE, SI, SK,  
SM, TR), OAPI (BF, BJ, CF, CG, CI, CM, GA, GN, GQ,  
GW, KM, ML, MR, NE, SN, TD, TG).

Declarations under Rule 4.17:

— as to applicant's entitlement to apply for and be granted a  
patent (Rule 4.17(ii))

Published:

— with international search report (Art. 21(3))

(54) Title: ABSORBENT PRODUCT COMPRISING INLET MATERIAL

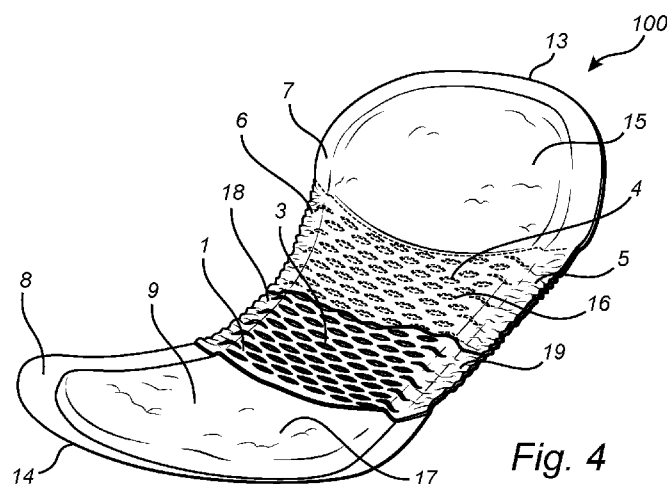

Fig. 4

(57) Abstract: Absorbent product comprising a liquid pervious topsheet, a liquid impervious backsheet and an absorbent core enclosed between the liquid pervious topsheet and liquid impervious backsheet. The absorbent product has in its longitudinal direction a crotch part and two end parts. The absorbent product comprises at least in its crotch part an inlet material having a plurality of openings. The plurality of openings in the inlet material are formed from a plurality of slits extending in the transversal direction of the absorbent product and that openings have been formed from the slits by expanding the continuous inlet material in the longitudinal direction of the absorbent product. The liquid inlet material has in its transversal direction of the absorbent product a central region and two edge regions. The openings are located in the central region so that the central region of the material with the plurality of openings has a lesser degree of elasticity than the edge regions.



## ABSORBENT PRODUCT COMPRISING INLET MATERIAL

### TECHNICAL FIELD

- 5 The present invention relates to an absorbent product comprising a liquid pervious topsheet, a liquid impervious backsheet and an absorbent core enclosed between the liquid pervious topsheet and liquid impervious backsheet. The absorbent product has in its longitudinal direction a crotch region and two end regions wherein at least the crotch region comprises an  
10 inlet material having a plurality of openings.

### BACKGROUND

For absorbent products such as incontinence shields there are high requirements that they are discreet, soft and comfortable to wear and at the same time have a reliable security against leakage.

- 15 Incontinence shields have to be sized and configured to fit in the limited space available in the crotch portion of the underwear so the products are by necessity designed with a relatively small width. For this reason, a particular problem with such products is that they may leak at the side edges, before the full absorption capacity of the product has been utilized.

20

- Side leakage may occur as a consequence of absorbed fluid being dispersed equally fast in all directions from the point where the fluid enters the product. This will lead to the fluid escaping the product at the side edges before being distributed to the end portions. Another cause of side leakage may be when  
25 the intake capacity of the product is insufficient to allow all fluid that is exuded onto the product to directly enter inside the product. Instead, the fluid will flow on the top sheet and out over the side edges where it can leak out and soil the wearer's clothing.

The urine fluid is normally not exuded in a steady flow but as sudden gushes of relatively large volume under high pressure and during a very short time period.

- 5 Accordingly, it would be desirable if the incontinence shield was able to receive and contain the emitted fluid with corresponding speed.

Although the prior art liquid inlet material may alleviate the side leakage problem to some extent, there is still a need for further improvements of the  
10 side leakage security for the kind of absorbent article that is worn in the crotch portion of an undergarment.

## DESCRIPTION

In accordance with the invention, there is provided an absorbent product  
15 having improved leakage security and fit.

The absorbent product comprising a liquid pervious topsheet, a liquid impervious backsheet and an absorbent core enclosed between the liquid pervious topsheet and liquid impervious backsheet. The absorbent product  
20 has in its longitudinal direction a crotch part and two end parts wherein the absorbent product at least in its crotch part comprises an inlet material having a plurality of openings. The plurality of openings in the inlet material is formed from slits extending in the transversal direction of the absorbent product that have been expanded in the longitudinal direction of the  
25 absorbent product. The liquid inlet material has in the transversal direction of the absorbent product a central region and two edge regions. The openings are located in the central region so that the central region of the material with the plurality of openings has a lesser degree of elasticity than the edge regions.

An effect of having a central region of the material with slits and edge regions of the material without slits will, after the material has been extended so that openings have been formed from the slits, lead to different elasticity in different regions of the material. The openings in the central region of the inlet material will give the material in this region a lower degree of elasticity than the edge regions free from openings. A greater degree of elasticity of the edge regions than in the central region of the crotch part is advantageous since the edge region of the inlet material will function as leg elastics and has a greater elasticity than the central part of the inlet material. The absorbent product may also obtain a bowl shape in the crotch region as a result of an elastic contraction of the edge regions of the inlet material having a greater elasticity than the central region of the inlet material.

Another advantage with edge regions without openings is that the edges may function also as liquid edge barriers decreasing the risk for side leakage.

One advantage with openings in the central region of the inlet material is that the liquid inlet into the product is improved. An alternative way of creating openings in a material would be to punch/perforate. However, a slitting method is advantageous over punching/perforating since no material is cut out from the web. This saves money due to less waste of material and also improves the handling in the production process by avoiding having a lot of small pieces cut out from the material that may otherwise contaminate both the process equipment and the final product.

The inlet material has to be able to absorb sudden gushes of relatively large volume during a very short time period and with the present disclosure it is possible to provide an inlet material with a plurality of openings and leg elastic material, of the same continuous material sheet.

Since the edge regions extending in the longitudinal direction of the absorbent product will function as leg elastics and support in creating a bowl shape in the crotch area, there is no need for a separate material sheet/element to create the leg elastics. The inlet material and the material for the leg elastics are the same continuous material sheet.

The inlet material may be located between the top sheet and the absorbent core or the inlet material may be the liquid permeable top sheet or part thereof.

The inlet material may have a greater width than the absorbent core. If the absorbent core comprises more than one layer, the inlet material may have a greater width than at least one of the layer in the absorbent core.

The central region of the inlet material may have a greater width, at least in the crotch part of the absorbent product, than the absorbent core. An advantage by having a greater width of the central region of the inlet material than the absorbent core, is that the plurality of openings extends over the absorbent core and also a part outside the absorbent core in the transversal direction of the product so there will be a part of the absorbent product located in the transversal direction between the absorbent core and the leg elastic region which is the edge region, with not so much material (no absorbent core and an inlet material with a plurality of openings), and this part will, due to a hinge effect, make it easier for the edge region with greater elasticity to retract the absorbent product into a bowl shaped product.

The inlet material has in the transversal direction of the absorbent product two edge regions and a central region between the edge regions and the

edge region may be at least 5 mm along the whole side edge of the product. Otherwise, it will be more difficult for the edge regions to function as leg elastics and retract the absorbent product into a bowl shape in the crotch region.

5

The width of the opening in the longitudinal direction of the absorbent product may be 0.2 to 3.0, or 0.5 to 1.0 of the length of the opening in the transversal direction.

- 10 The inlet material may have been extended 30% to 200% from the original length of the unexpanded inlet material.

The inlet material may be hydrophobic. An advantage with a hydrophobic material is that hydrophobic edge regions free of openings will function as liquid barriers and will decrease the risk for edge leakage. Also, a hydrophobic inlet material is preferred from a skin care view since a dry surface close to the user's skin may decrease the risk for bacterial growth and skin irritations.

- 20 The liquid inlet material may be of a foam material. An advantage to have a foam material as liquid inlet material is that such a product is experienced as soft and is also aesthetically pleasing for many users. The ability of a foam material to spring back, to return to substantially its original form after having been exposed to outer loading is also an important property. Since the foam material has a continuous structure, it exhibits good pliability and also ability to spring back following outer loading.

25

Foam material may have an open cell structure or a closed cell structure. Foam used as a liquid-receiving foam layer in an absorbent product, is often foam with open cells so that the liquid easily enters the foam and also the absorbent core below. However, with the slit openings it is possible also to use foam having closed cells. An advantage with foam comprising closed cells is that the liquid will not easily enter the foam structure itself, and therefore the foam material will be kept in a more dry condition than foam with open pore cells that are connected with each other.

10 The inlet material may also be a fibrous material, for example a nonwoven or laminate thereof.

The distance between the openings in the liquid inlet material may be 1.5 to 5.0 mm, or 1.5 to 2.5 mm. An advantage with a rather short distance between the openings is that the total open area will be high and the inlet rate will be fast.

The total open area of the openings in the horizontal plane of the inlet material in the central region is 40 to 70 % of the total area in the horizontal plane of the inlet material in the central region.

20

The slits may have a slit length between 5.0 to 20.0 mm, 7.0 to 20 mm, 10.0 to 20.0. By having a slit length that is at least 5 mm, or at least 7 mm, or at least 10.0 mm the urine will reach the absorbent core below the inlet material more easily.

25

The absorbent product may have a narrower width in the crotch part and may be broader in the end parts. The reason for this is to shape the product to

optimizing the fit to the body during use. However, it may be advantageous for process reasons to have the central region of the inlet material located substantially parallel to a longitudinal center line in the longitudinal direction of the absorbent product and not following the outer contour of the absorbent product.

The slits may be provided in staggered rows extending in the transversal direction of the absorbent product and has a slit distance B between the ends of two mutually sequential slits in the staggered row, a slit length A, and a row distance C between two adjacent rows.

The inlet material and the layer directly beneath the inlet material may have different color. This is an advantage since the plurality of openings will be visualized more distinct. For example, the inlet material may be colored or a layer between the inlet material and the absorbent core may be colored. A layer between the inlet material and the absorbent core may for example be a nonwoven. If the absorbent core/or part of the absorbent core has a shape with a less extension than the inlet material it may be an advantage if a material layer directly beneath the inlet material is colored since the less extension of the absorbent core beneath the colored layer will not so easily be recognized by the user.

The absorbent product may be an incontinence shield. The slit openings in the central region and the slit free edge regions improve the urine inlet rate as well as the bowl shape, which is especially advantageous for this kind of absorbent products.

The length of the inlet material in the longitudinal direction of the absorbent product may be 20 to 80% of the absorbent product in the longitudinal direction.

5 The absorbent product has a front end part and a back end part and a crotch part located between the front end part and the back end part.

The length of the front end part in its longitudinal direction of the absorbent product may be shorter than the length of the back end part in the longitudinal direction of the absorbent product.

10 The length of the back end part in its longitudinal direction of the absorbent product may be shorter than the length of the front end part in the longitudinal direction of the absorbent product.

The total length of the incontinence shield may be 15 to 50 cm. The total length of the incontinence shield may be less than 50 cm, or less than 30 cm.

15 The length of the inlet material in the longitudinal direction of the incontinence shield may be 20 to 80% of the total length of the incontinence shield in the longitudinal direction.

## SHORT DESCRIPTION OF FIGURES

Figure 1A shows a top view of a slit inlet material according to an embodiment of the invention before it has been expanded.

5

Figure 1B shows a top view the inlet material according to Fig. 1A after it has been expanded, i.e. after the slits have been opened to form openings.

10 Figure 2 shows a cross-sectional view of an incontinence shield according to an embodiment of the invention.

Figure 3 shows the incontinence shield of Figure 2, seen from the side which will be facing the user when it is worn.

15 Figure 4 also shows the incontinence shield of Figure 2, seen from the side which will be facing the user when it is worn.

## DETAILED DESCRIPTION OF THE FIGURES

The invention will now be described by means of examples referring to Fig  
20 1A-B and Figures 2-4. Figure 1A shows a top view of a slit inlet material according to an embodiment of the invention before it has been expanded. Figure 1A shows a top view of the inlet material 1 after provision of transversal slits 2. The slits 2 in Fig. 1A are straight, but may have any suitable shape such as for example wave-shaped. The slits 2 are provided in  
25 staggered rows extending in the transversal direction of the inlet material 1 having a slit length A and a slit distance B between the ends of two mutually

sequential slits in the staggered row, and a row distance C between two adjacent rows. The inlet material 1 has in its transversal direction a central region 4 with slits and two edge regions 5, 6 without slits.

- 5 Figure 1B shows a top view of the inlet material 1 according to Fig. 1A after it has been expanded in the direction transversal to the slit 2 direction, i.e. after the slits 2 have been opened to form openings 3.

Figure 2 shows a cross-sectional view of the different layers in the  
10 incontinence shield according to an embodiment of the invention. The incontinence shield 100 comprises a liquid permeable topsheet 7, a liquid impermeable backsheet 8, and an absorbent core 9 enclosed between the topsheet 7 and the backsheet 8, and an inlet material 1 arranged between the topsheet 7 and the absorbent core 9. The incontinence shield 100 has in  
15 its longitudinal direction a front end part 15, a back end part 17 and a crotch part 16 intermediate the front end part 15 and the back end part 17. The inlet material 1 is located in the crotch part 16 of the product and the length of the front end part 15 in its longitudinal direction of the incontinence shield 100 is shorter than the length of the back end part 17 in the longitudinal direction of  
20 the incontinence shield 100. The crotch part 16 is a portion which is intended to be placed against the crotch of a wearer during use of the product and to constitute the main acquisition area for body fluid that reaches the incontinence shield 100.

The topsheet 7 and the backsheet 8 of the incontinence shield 100 extend  
25 together laterally outside of the absorbent core 9 along the whole circumference of the absorbent core 9. The topsheet 7 consists of any material which is suitable for the purpose, i.e. soft and liquid pervious. Examples of commonly found topsheet 7 materials are nonwoven materials, perforated plastic films, plastic or textile mesh, and fluid permeable foam

layers. Laminates consisting of two or more topsheet materials are also commonly employed, as are top sheets consisting of different materials within different parts of the fluid permeable wearer-facing surface.

The backsheet 8 is fluid impermeable. However, backsheet materials that are only fluid repellent may be used particularly in instances where relatively small amounts of urine are expected to be taken up. The backsheet 8 is commonly constituted by a thin, flexible, fluid-impermeable plastic film, but fluid-impermeable nonwoven materials, fluid impermeable foams and fluid impermeable laminates are also contemplated within the scope of the invention. The backsheet 8 may be breathable, implying that air and/or vapor may pass through the backsheet 8. Furthermore, the backsheet 8 may have an outer, garment-facing surface of a textile material such as nonwoven.

The absorbent core 9 may be made up of any suitable absorbent or fluid uptake material as known in the art, such as one or more layers of cellulose fluff pulp, foam, fibre waddings, etc. The absorbent core 9 may contain fibers or particles of highly absorbent polymer material, commonly known as superabsorbents, which are materials having the ability to absorb and retain large quantities of fluid upon formation of a hydrogel. The superabsorbents may be mixed with cellulose fluff pulp and/or may be arranged in pockets or layers in the absorbent core 9. The fibres may be pulp fibres and the superabsorbent material may be polyacrylate-based particles. The absorbent core 9 may further incorporate components for improving the properties of the absorbent core 9. Some examples of such components are binder fibers, fluid-dispersing materials, wetness indicators etc., as known in the art. The incontinence shield 100 has an elongate, generally rectangular shape when fully extended in all directions. Any suitable shape may be used for the absorbent product, such as hourglass shape, trapezoidal shape, etc. The incontinence shield has a transversal rear end edge 14 intended to be orientated rearwards during use of the absorbent article, and a front end edge 13 intended to be facing forwards towards the abdomen of the wearer. The incontinence shield 100 may further include fastening means for

fastening of the absorbent product inside a supporting pant garment, such as a pair of underpants. The fastening means may be in the form of two longitudinally extending bands of pressure sensitive adhesive arranged on the garment-facing surface of the backsheet 8. The fastening means can be covered by a releasable protective layer, e.g. a siliconized paper, a nonwoven or any other releasable material as is known in the art. Before placing the absorbent product in the supporting pant garment, the protective layer is removed from the fastening means to expose the adhesive and make it available for fastening to the pant garment.

10

The fastening means is optional to the invention and may be omitted, if desired. When using an adhesive fastening means, any suitable adhesive pattern may be used such as full coating of the backsheet, one or more longitudinal adhesive band, transverse bands, dots, circles, curves, stars, etc.

15

The inlet material 1 in Fig. 2 is situated above the absorbent core 9 and beneath and in direct contact with the topsheet 7. The absorbent core 9 of the incontinence shield 100 comprises one absorbent layer, but the absorbent core 9 may also comprise two or more absorbent layers. The absorbent core 9 may be homogeneous structures or may in themselves be layered structures such as absorbent laminates of the same or different materials. The absorbent layers may have uniform thickness or may vary in thickness in different parts of the layers. Similarly, the basis weight and composition may vary within the absorbent layers. By way of example, an absorbent layer may comprise a mixture of absorbent and/or non-absorbent fibers and superabsorbent material, wherein the ratio of superabsorbent material to fibers may vary in the layer. The absorbent core 9 may have any suitable shape, such as an hourglass shape with widened end portions and a

20  
25

narrow portion in the crotch portion, or a rectangular shape. The inlet material 1 in the incontinence shield illustrated in figures 2-4 has a rectangular shape.

Figure 3 shows the incontinence shield of Figure 2, seen from the side which will be facing the user when it is worn. In figure 3 the edge regions 5, 6 of the inlet material 1 is forming the leg elastics 18, 19. The edge regions 5, 6 have a greater elasticity than the central region 4 of the inlet material 1 and functions as leg elastics 18,19. The leg elastics 18,19 are the edge regions 5,6 of the inlet material 1. Figure 4 also shows the incontinence shield (100) of Figure 2, seen from the side which will be facing the user when it is worn. In figure 4 the bowl shape of the incontinence shield 100 formed by the elastic contraction of the edge regions 5,6 of the inlet material 1 is illustrated. The incontinence shield 100 described in figures 2-4 is only one illustration of an absorbent product suitable for the present invention.

## CLAIMS

1. Absorbent product comprising a liquid pervious topsheet (7), a liquid  
impervious backsheet (8) and an absorbent core (9) enclosed between the  
5 liquid pervious topsheet (7) and liquid impervious backsheet (8), having in its  
longitudinal direction a crotch part (16) and two end parts (15,17) wherein the  
absorbent product at least in its crotch part (16) comprises an inlet material  
(1) having a plurality of openings (3),

c h a r a c t e r i z e d in that the plurality of openings (3) in the inlet material  
10 (1) are formed from a plurality of slits (2) extending in the transversal  
direction of the absorbent product and that openings (3) have been formed  
from the slits (2) by expanding the continuous inlet material (1) in the  
longitudinal direction of the absorbent product (100) , and that the liquid inlet  
material (1) in the transversal direction of the absorbent product (100) has a  
15 central region (4) and two edge regions (5,6) and that the plurality of  
openings (3) are located in the central region (4) so that the central region (4)  
of the inlet material with the plurality of openings (3) has a lesser degree of  
elasticity than the edge regions (5,6).

20 2. Absorbent product (100) according to claim 1, wherein the edge regions  
(5,6) of the inlet material (1) has a greater elasticity than the central region  
(4) of the inlet material (1).

3. Absorbent product according to claim 2, wherein the crotch part (16) has a  
25 bowl shape.

4. Absorbent product (100) according to any of claims 1-3, wherein the inlet  
material (1) is located in the crotch part (16) only.

5. Absorbent product (100) according to any of previous claims, wherein the inlet material (1) is located between the top sheet (7) and the absorbent core (9).

5

6. Absorbent product (100) according to any of claims 1-4, wherein the inlet material (1) is the liquid permeable top sheet (7) or part thereof.

7. Absorbent product (100) according to claim 5 or 6, wherein the inlet material (1) at least in the crotch part (16) has a greater width than the absorbent core (9).

10

8. Absorbent product (100) according to claim 7, wherein the central region (4) of the inlet material (1) at least in the crotch part (16) also has a greater width than the absorbent core (9).

15

9. Absorbent product (100) according to any of claims 5-8, wherein the liquid pervious topsheet (7) and the liquid impervious backsheet (8) have substantially same or greater width in the crotch part (16) than the inlet material (1).

20

10. Absorbent product (100) according to any of previous claims, wherein the edge regions (5,6) have a width that is of least 5.0 mm.

11. Absorbent product (100) according to any of previous claims, wherein the length of the openings (3) in the transversal direction of the absorbent product are 5.0 to 20.0 mm, 7.0 to 20.0 mm or 10.0 to 20.0 mm.
- 5 12. Absorbent product (100) according to any of previous claims, wherein the width of the openings (3) in the longitudinal direction of the absorbent product (100) is 0.2 to 3.0, or 0.5 to 1.0 of the length of the opening (3) in the transversal direction.
- 10 13. Absorbent product (100) according to any of previous claims, wherein the inlet material (1) has been extended 30% to 200% from the original length of the unexpanded inlet material.
- 15 14. Absorbent product (100) according to any of previous claims, wherein the inlet material (1) is hydrophobic.
- 15 15. Absorbent product (100) according to any of previous claims, wherein the inlet material (1) is a foam material.
- 20 16. Absorbent product (100) according to any of claim 1-12, wherein the inlet material (1) is a nonwoven.
17. Absorbent product (100) according to any of previous claims, wherein the distance between the openings (3) are 1.5 to 5.0 mm, or 1.5 to 2.5 mm.

18. Absorbent product (100) according to any of previous claims, wherein the total open area in the horizontal plane of the product formed by the plurality openings (3) in the central region (4) is 40% to 70 % of the total area in the horizontal plane in the central region (4).

5

19. Absorbent product (100) according any of previous claims, wherein the inlet material (1) and the layer directly below the inlet material have different colors.

10 20. Absorbent product (100) according to any of previous claims, wherein the absorbent product is an incontinence shield (100).

15 21. Incontinence shield (100) according to claim 20, wherein the length of the inlet material (1) in the longitudinal direction of the incontinence shield is 20 to 80% of the total length of the incontinence shield (100) in the longitudinal direction.

20 22. Incontinence shield (100) according to any of claims 20-21, wherein the incontinence shield (100) is less than 50 cm, or less than 30 cm in its longitudinal direction.

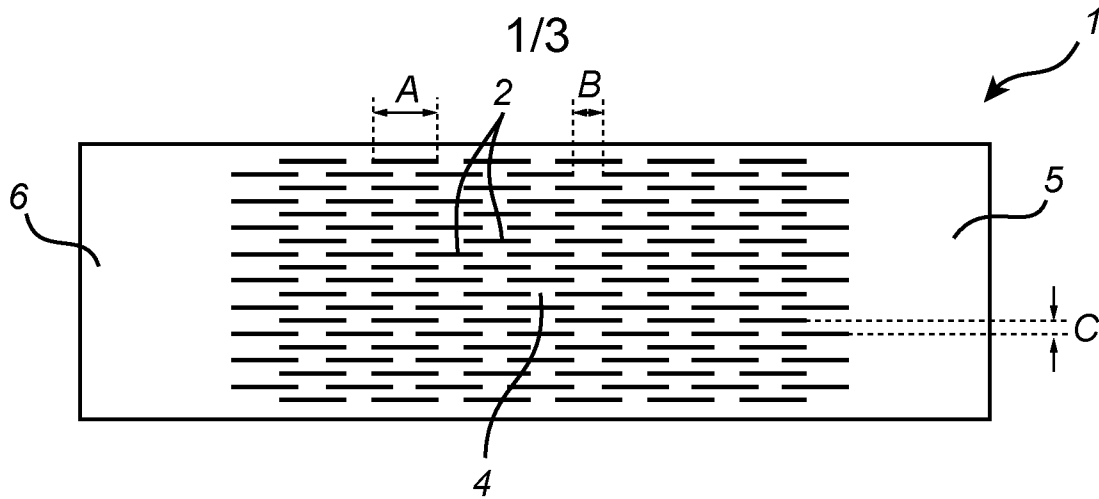

Fig. 1A

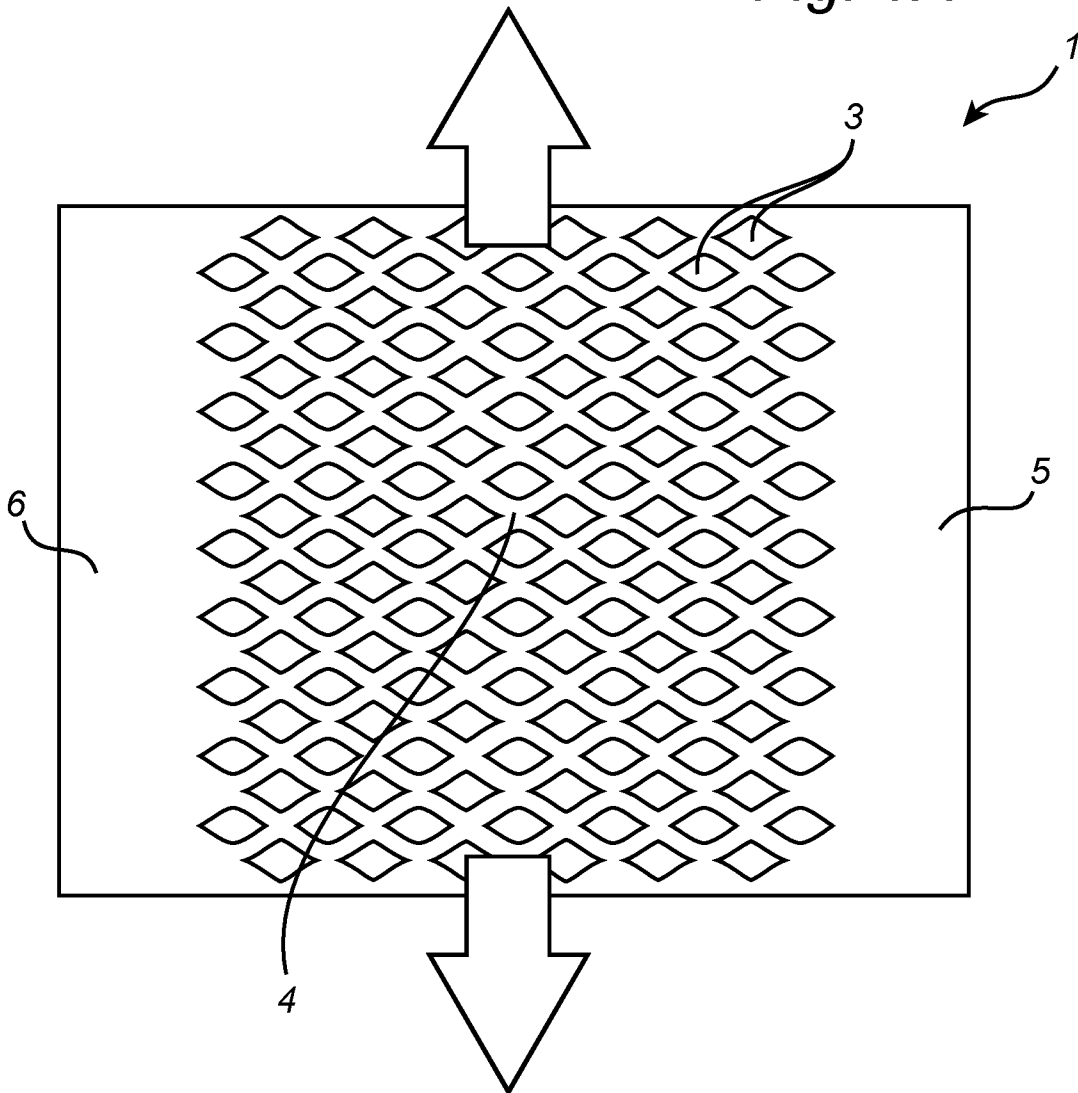
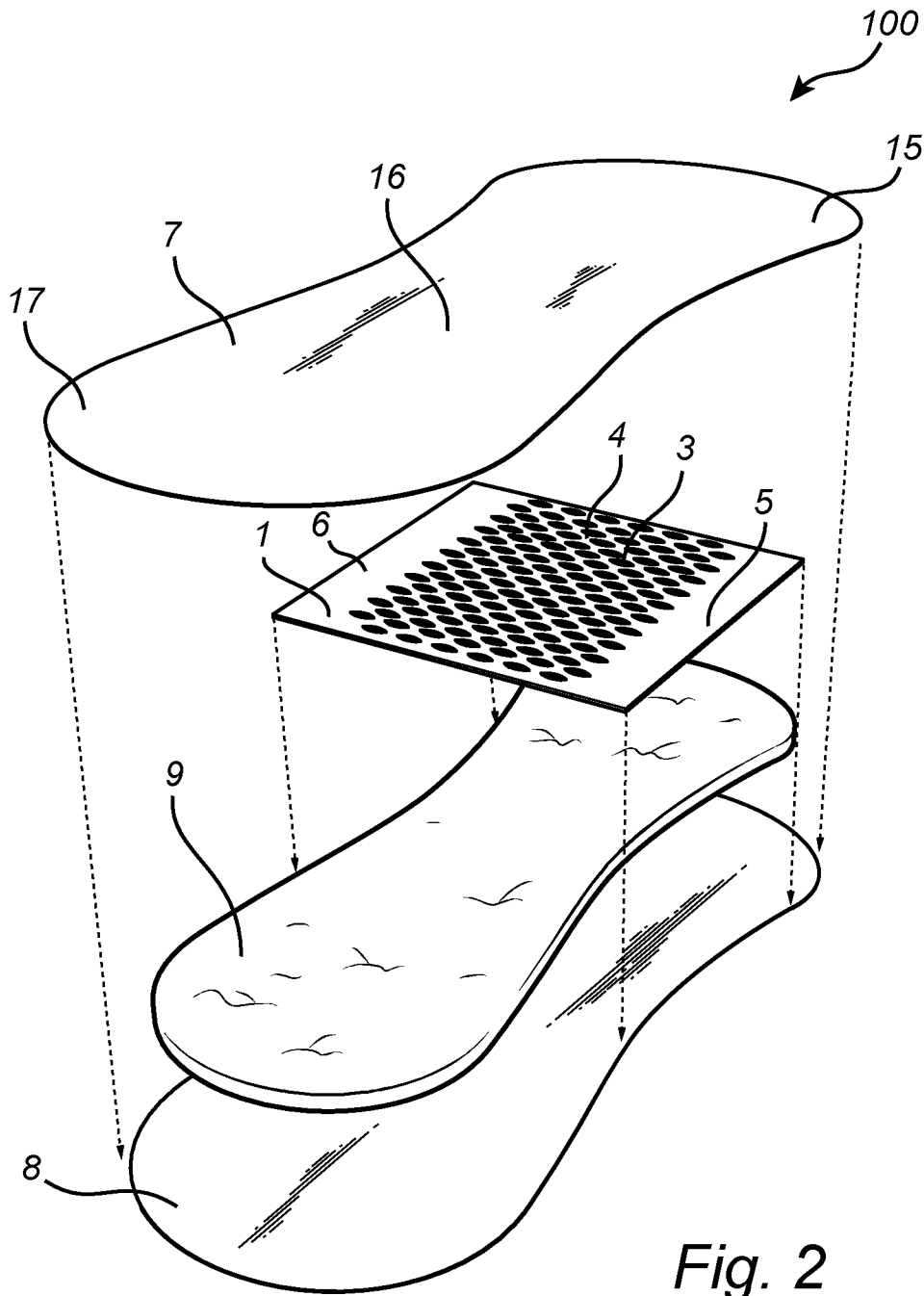

Fig. 1B



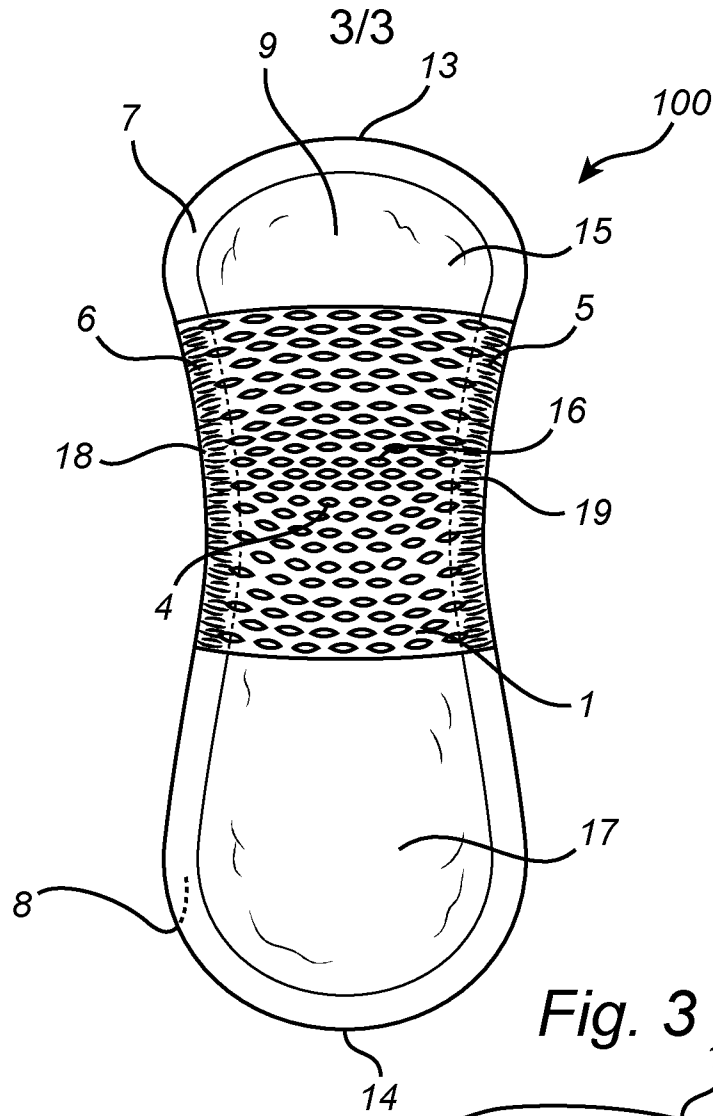

Fig. 3

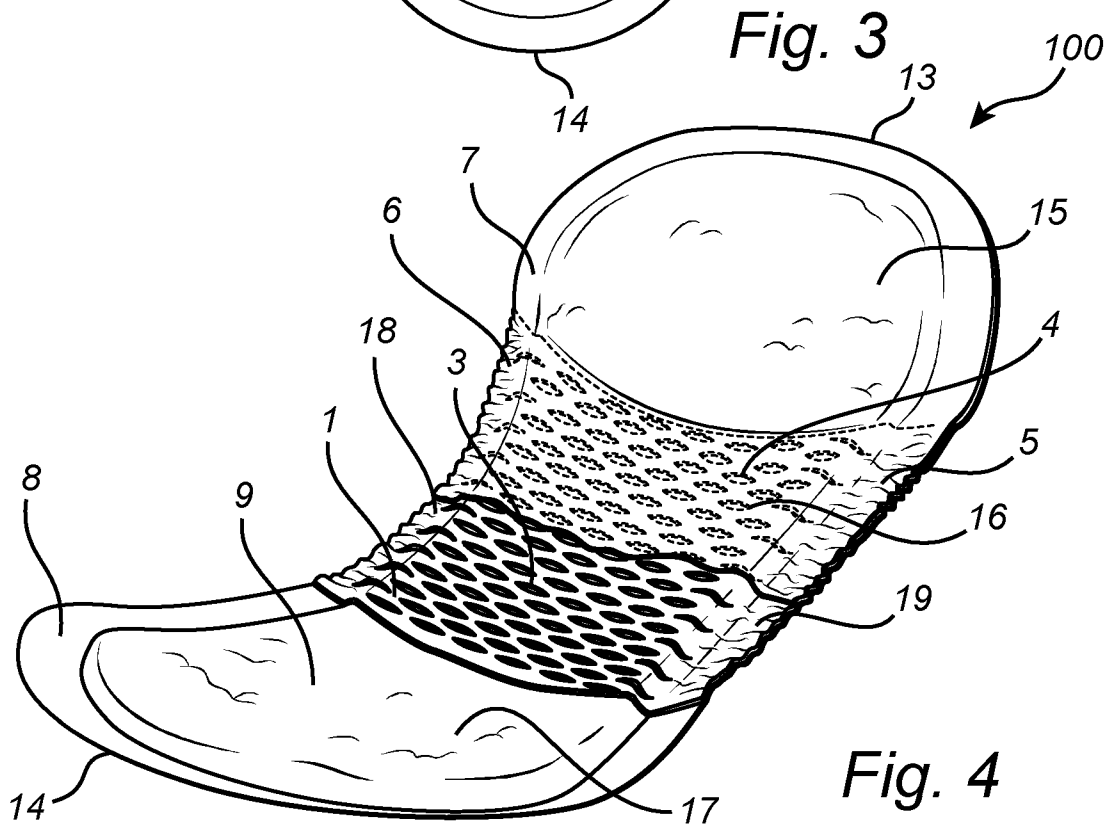

Fig. 4

## INTERNATIONAL SEARCH REPORT

International application No.  
PCT/SE2015/050671

A. CLASSIFICATION OF SUBJECT MATTER		
IPC: see extra sheet		
According to International Patent Classification (IPC) or to both national classification and IPC		
B. FIELDS SEARCHED		
Minimum documentation searched (classification system followed by classification symbols)		
IPC: A61F, B32B		
Documentation searched other than minimum documentation to the extent that such documents are included in the fields searched		
SE, DK, FI, NO classes as above		
Electronic data base consulted during the international search (name of data base and, where practicable, search terms used)		
EPO-Internal, PAJ, WPI data, BIOSIS, COMPENDEX, MEDLINE		
C. DOCUMENTS CONSIDERED TO BE RELEVANT		
Category*	Citation of document, with indication, where appropriate, of the relevant passages	Relevant to claim No.
A	WO 9301781 A1 (PROCTER & GAMBLE), 4 February 1993 (1993-02-04); page 26, paragraph [0003] - page 27, paragraph [0001]; page 67, paragraph [0003] - page 72, paragraph [0004]; figures 1-7 --	1-22
A	US 5611790 A (OSBORN III THOMAS W ET AL), 18 March 1997 (1997-03-18); column 18, line 55 - column 18, line 63; column 19, line 19 - column 19, line 21; column 27, line 16 - column 27, line 25; column 70, line 62 - column 74, line 20; figures 16,84-87 --	1-22
<input checked="" type="checkbox"/> Further documents are listed in the continuation of Box C. <input checked="" type="checkbox"/> See patent family annex.		
* Special categories of cited documents: "A" document defining the general state of the art which is not considered to be of particular relevance "E" earlier application or patent but published on or after the international filing date "L" document which may throw doubts on priority claim(s) or which is cited to establish the publication date of another citation or other special reason (as specified) "O" document referring to an oral disclosure, use, exhibition or other means "P" document published prior to the international filing date but later than the priority date claimed "T" later document published after the international filing date or priority date and not in conflict with the application but cited to understand the principle or theory underlying the invention "X" document of particular relevance; the claimed invention cannot be considered novel or cannot be considered to involve an inventive step when the document is taken alone "Y" document of particular relevance; the claimed invention cannot be considered to involve an inventive step when the document is combined with one or more other such documents, such combination being obvious to a person skilled in the art "&" document member of the same patent family		
Date of the actual completion of the international search 29-01-2016		Date of mailing of the international search report 02-02-2016
Name and mailing address of the ISA/SE Patent- och registreringsverket Box 5055 S-102 42 STOCKHOLM Facsimile No. + 46 8 666 02 86		Authorized officer John Sjöberg Telephone No. + 46 8 782 28 00

## INTERNATIONAL SEARCH REPORT

International application No.  
PCT/SE2015/050671

C (Continuation). DOCUMENTS CONSIDERED TO BE RELEVANT		
Category*	Citation of document, with indication, where appropriate, of the relevant passages	Relevant to claim No.
A	WO 2011115537 A1 (SCA HYGIENE PROD AB ET AL), 22 September 2011 (2011-09-22); abstract; page 1, line 1 - page 1, line 12; figure 2e --	1-22
A	WO 2014085974 A1 (KIMBERLY CLARK CO ET AL), 12 June 2014 (2014-06-12); abstract; page 34, line 21 - page 35, line 12; figure 3 --	1-22
A	WO 9901098 A1 (MOELNLYCKE AB ET AL), 14 January 1999 (1999-01-14); abstract; page 9, line 22 - page 9, line 36 --	1-22
A	WO 2006102974 A1 (CONCEPTS FOR SUCCESS ET AL), 5 October 2006 (2006-10-05); abstract; claims 1, 8 --	1-22
A	CA 2019455 A (MOKRY PATTI J), 8 November 1991 (1991-11-08); abstract; figure 1 -- -----	1-22

**Continuation of:** second sheet

**International Patent Classification (IPC)**

**A61F 13/537** (2006.01)

**A61F 13/472** (2006.01)

**A61F 13/475** (2006.01)

**B32B 3/10** (2006.01)

**B32B 5/04** (2006.01)

**B32B 5/24** (2006.01)

**B32B 37/14** (2006.01)

## INTERNATIONAL SEARCH REPORT

Information on patent family members

International application No.

PCT/SE2015/050671

WO	9301781 A1	04/02/1993	AT	142468 T	15/09/1996
			AT	155032 T	15/07/1997
			AT	149823 T	15/03/1997
			AT	148831 T	15/02/1997
			AT	143247 T	15/10/1996
			AT	174208 T	15/12/1998
			AU	662350 B2	31/08/1995
			AU	735795 B2	12/07/2001
			AU	662757 B2	14/09/1995
			AU	2402592 A	23/02/1993
			AU	2399392 A	23/02/1993
			AU	2383192 A	23/02/1993
			AU	2383092 A	23/02/1993
			AU	5951498 A	01/10/1998
			AU	5844198 A	04/06/1998
			AU	4021995 A	29/02/1996
			AU	4021895 A	29/02/1996
			AU	2507695 A	14/09/1995
			AU	2507595 A	14/09/1995
			AU	2421392 A	23/02/1993
			AU	2420492 A	23/02/1993
			AU	8307898 A	24/12/1998
			AU	8189298 A	15/10/1998
			AU	5954298 A	01/10/1998
			BR	9205320 A	05/04/1994
			BR	9205330 A	16/11/1993
			BR	9205329 A	05/10/1993
			CA	2092197 C	20/07/1999
			CA	2092203 C	06/07/1999
			CA	2092202 C	16/03/1999
			CA	2092199 C	13/06/2000
			CA	2092198 C	23/03/1999
			CA	2243115 A1	24/01/1993
			CA	2243108 A1	24/01/1993
			CA	2243106 C	22/10/2002
			CA	2243056 C	05/11/2002
			CA	2243053 C	19/11/2002
			CA	2243049 C	12/11/2002
			CA	2243039 C	12/11/2002
			CA	2195690 C	30/01/2001
			CA	2092204 C	23/12/1997
			CA	2243119 A1	24/01/1993
			CA	2243117 A1	24/01/1993
			CA	2243117 A1	24/01/1993

## INTERNATIONAL SEARCH REPORT

Information on patent family members

International application No.

PCT/SE2015/050671

WO	9301781 A1	04/02/1993	AT	142468 T	15/09/1996
			AT	155032 T	15/07/1997
			AT	149823 T	15/03/1997
			AT	148831 T	15/02/1997
			AT	143247 T	15/10/1996
			AT	174208 T	15/12/1998
			AU	662350 B2	31/08/1995
			AU	735795 B2	12/07/2001
			AU	662757 B2	14/09/1995
			AU	2402592 A	23/02/1993
			AU	2399392 A	23/02/1993
			AU	2383192 A	23/02/1993
			AU	2383092 A	23/02/1993
			AU	5951498 A	01/10/1998
			AU	5844198 A	04/06/1998
			AU	4021995 A	29/02/1996
			AU	4021895 A	29/02/1996
			AU	2507695 A	14/09/1995
			AU	2507595 A	14/09/1995
			AU	2421392 A	23/02/1993
			AU	2420492 A	23/02/1993
			AU	8307898 A	24/12/1998
			AU	8189298 A	15/10/1998
			AU	5954298 A	01/10/1998
			BR	9205320 A	05/04/1994
			BR	9205330 A	16/11/1993
			BR	9205329 A	05/10/1993
			CA	2092197 C	20/07/1999
			CA	2092203 C	06/07/1999
			CA	2092202 C	16/03/1999
			CA	2092199 C	13/06/2000
			CA	2092198 C	23/03/1999
			CA	2243115 A1	24/01/1993
			CA	2243108 A1	24/01/1993
			CA	2243106 C	22/10/2002
			CA	2243056 C	05/11/2002
			CA	2243053 C	19/11/2002
			CA	2243049 C	12/11/2002
			CA	2243039 C	12/11/2002
			CA	2195690 C	30/01/2001
			CA	2092204 C	23/12/1997
			CA	2243119 A1	24/01/1993
			CA	2243117 A1	24/01/1993
			CA	2243117 A1	24/01/1993

## INTERNATIONAL SEARCH REPORT

Information on patent family members

International application No.

PCT/SE2015/050671

US	5611790 A	18/03/1997	US	5702382 A	30/12/1997
WO	2011115537 A1	22/09/2011	CN	102802582 A	28/11/2012
			EP	2547305 A1	23/01/2013
			JP	5493050 B2	14/05/2014
			JP	2013521927 A	13/06/2013
			US	20130012898 A1	10/01/2013
WO	2014085974 A1	12/06/2014	AU	2012396080 A1	09/07/2015
			CN	104780883 A	15/07/2015
			EP	2928433 A1	14/10/2015
			KR	20150093712 A	18/08/2015
			US	20150313766 A1	05/11/2015
WO	9901098 A1	14/01/1999	AU	8249798 A	25/01/1999
			CO	5060492 A1	30/07/2001
			DE	69818822 T2	29/07/2004
			EP	0993291 B1	08/10/2003
			JP	2002510233 A	02/04/2002
			PL	337734 A1	28/08/2000
			SE	9702545 L	01/02/1999
			SE	514292 C2	05/02/2001
			TN	SN98128 A1	13/06/2000
			TW	406016 B	21/09/2000
WO	2006102974 A1	05/10/2006	CA	2600735 A1	05/10/2006
			EP	1865905 B1	27/02/2013
			JP	2008534092 A	28/08/2008
			JP	4922289 B2	25/04/2012
			US	20080172020 A1	17/07/2008
CA	2019455 A	08/11/1991	NONE		