

W. PECK.
GRINDING MILL.

No. 102,588.

Patented May 3, 1870.

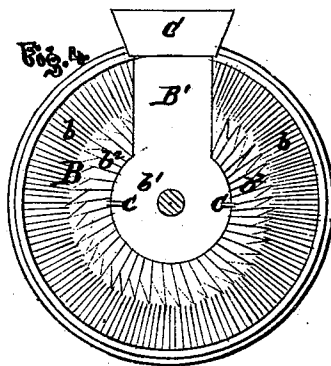
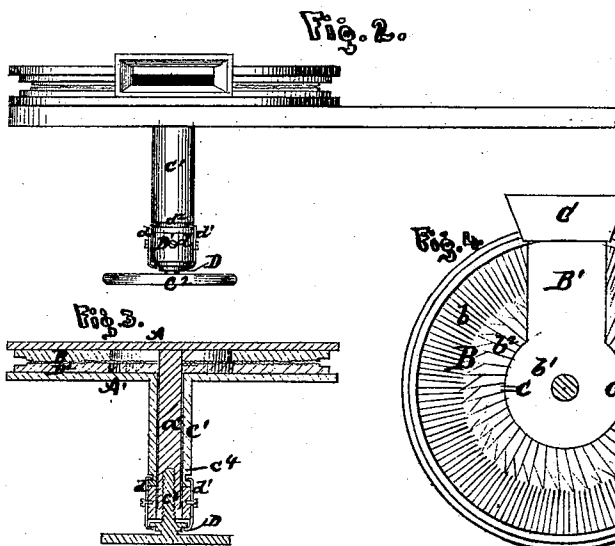
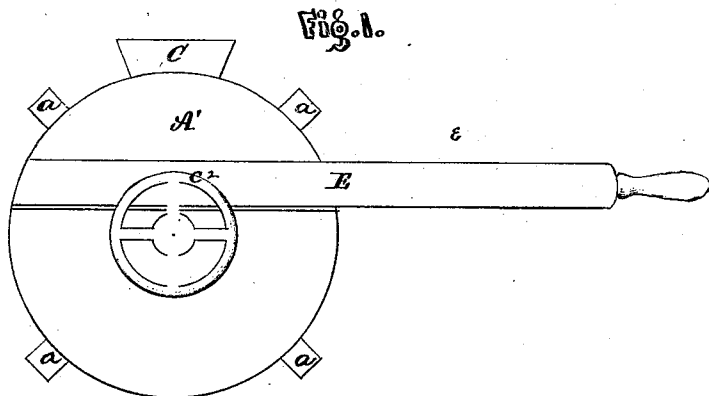

Witnesses
Fred Thomas
E. Williams

Inventor.
W. Peck by
H. W. Beadle, atty

UNITED STATES PATENT OFFICE.

WALTER PECK, OF ROCKFORD, ILLINOIS.

IMPROVED GRINDING-MILL.

Specification forming part of Letters Patent No. 102,588, dated May 3, 1870.

To all whom it may concern:

Be it known that I, WALTER PECK, of Rockford, in the county of Winnebago and State of Illinois, have invented new and useful Improvements in Grinding-Mills; and I do hereby declare that the following is a full and exact description of the same, reference being had to the accompanying drawings, and to the letters of reference marked thereon.

This invention relates to an improved method of grinding corn or other grain, whereby two vertical circular grinding-surfaces are employed, one being stationary and the other having a vibratory motion, to which end certain details of construction are employed, which will hereinafter more fully appear.

In the drawings, Figure 1 is a side elevation of my invention; Fig. 2, a plan view of the same; Fig. 3, a longitudinal central section through the line *x x*, Fig. 2; and Fig. 4, a side elevation of the stationary plate, the vibrating plate being removed.

To enable others skilled in the art to make and use my invention, I will now proceed to describe its construction and operation.

A A' represent circular metal plates of any suitable diameter, the plate A being bolted by the ears *a a*, &c., to any convenient surface, and rigidly attached to the shaft *a'*. To the inner side of the plate A is attached an annular plate, B, of hardened metal or other convenient material, having its upper portion cut away to form a channel, B', for the admission of grain.

b represents a series of radial grooves cut in the outer part of the inner surface of the plate B, and extending a little over one-half the distance across the same, where they are met by a series of tangential grooves, *b'*, of greater depth than the former, which conduct the grain from the circular chamber *b'* to the grinding-surfaces. The grooves *b'* are formed with one side beveling, and the other nearly at an angle with the surface of the plate, thereby forming sharp cutting-edges. About one-third of the grooves *b'* are cut deeper than the rest, in order to admit the grain more freely to the cutters and prevent the same from clogging. It will also be observed that the grooves *b* and *b'* have their cutting-edges in reversed positions, so that at each movement of the lever the grain is cut. The arrangement of the an-

gles is such, also, that when the grain is being cut with one set of edges the grain in the other is loosened up for the next cutting. These plates may be made in any desired form.

C C represent projections on the inner edge of the plate B, for the purpose of breaking cobs or other obstructions which may get between the plates.

C' represents the hopper, which is secured to the plate A and communicates with the passage B'. The plate A has a corresponding angular plate, B², attached thereto, which is similar in construction to the plate B, except that its continuity is unbroken.

c' represents a cylindrical case, through which the shaft *a'* passes.

*c*² is a hand-wheel provided with a screw, *c*³, which engages with a corresponding screw-thread, *c*⁴, in the end of the shaft *a'*. The screw *c*³ is provided with an annular grooved flange, D.

D' represents a collar, which surrounds the screw *c*³, and is provided with the set-screw *d*, by means of which it is held securely on the shaft *a'*, and with two clasps, *d' d'*, whose ends are bent at right angles and engage the grooved flange D and an annular groove, *d*², on the end of the case *c'*. The object of this latter arrangement is to efficiently regulate the distance between the grinding-plates, which is also effected by the screws *d*³ *d*⁴.

E represents a lever attached to the plate A', by means of which vibratory motion is imparted to the plate A'. The lever E may be operated by hand or other power, being especially adapted to mechanism where a crank is employed, as in windmills, for which attachment a staple or ring, *e*, is employed, which may be adjusted longitudinally at any desired point to regulate the length of stroke.

The operation of my invention is as follows: The grain is placed in any convenient receptacle above the hopper, and conducted thereto by a tube or spout, whence it passes down through the channel B', thence through the tangential grooves *b'* to the grinding-plates, and by its own gravity passes downward, and when ground sufficiently fine falls into a receptacle below. The distance between the cutting-plates is efficiently regulated by the hand-wheel *c*² and screws *c*³ and *c*⁴, which, when turned up, force the plate A' into closer prox-

imity with the plate A, which it is prevented from coming into actual contact with by the screws a^3 a^3 . When the distance between the plates is increased by unscrewing the wheel c^2 , the clasps d' d' hold the case c' firmly in position, thereby keeping all parts of each grinding-surface equidistant from the other. When desired to confine the plate in any position, and prevent accidental working of the hand-wheel, the set-screw d is operated, which presses firmly on the shaft a' and holds the same securely. The grinding-plates may be made of any suitable material—as white metal, hardened-like steel—and can be readily removed when worn off; or, if desired, small burr-stones may be used instead. In either case the general form and method of attachment are the same. This arrangement is one requiring but little power to operate it, and, as above mentioned, is especially adapted to wind-mills. Having no liability to clog, it can be put in operation by a very slight breeze, and

by the formation of its grinding-surfaces can be worked equally well by an upward or downward motion of the lever.

Having thus fully described my invention, what I claim as new, and desire to secure by Letters Patent, is—

1. The grinding-machine above described, consisting substantially of the plates A A', grinding-plates B B', shaft a' , case c' , lever E, hand-wheel c^2 , with screw c^3 , collar d , clasps d' d' , and grooves D d^2 , arranged and operated substantially as described.

2. The combination of the plates A A', provided with the grooves $b b^2$, with reversed cutting-edges, when arranged and operating as described, for the purpose set forth.

This specification signed and witnessed this 3d day of February, 1869.

WALTER PECK.

Witnesses:

G. W. FORD,

F. L. BLACKMAN.