

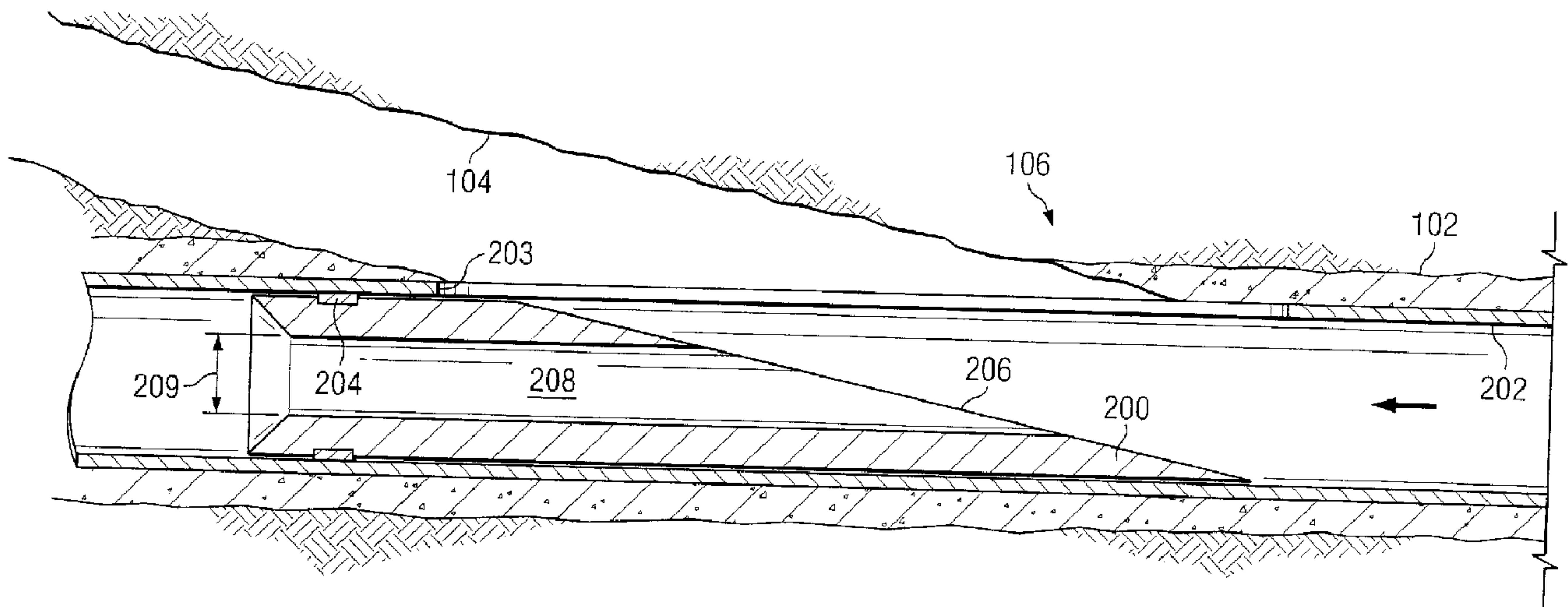

(22) Date de dépôt/Filing Date: 2004/02/24  
 (41) Mise à la disp. pub./Open to Public Insp.: 2005/08/05  
 (45) Date de délivrance/Issue Date: 2008/06/03  
 (30) Priorité/Priority: 2004/02/05 (US10/772,841)

(51) Cl.Int./Int.Cl. *E21B 7/06* (2006.01),  
*E21B 41/00* (2006.01), *E21B 43/08* (2006.01),  
*E21B 43/10* (2006.01), *E21B 43/14* (2006.01)  
 (72) Inventeur/Inventor:  
 PRATT, CHRISTOPHER ARNOLD, CA  
 (73) Propriétaire/Owner:  
 CDX GAS, L.L.C., US  
 (74) Agent: KIRBY EADES GALE BAKER

(54) Titre : METHODE ET SYSTEME DE REVETEMENT DE Puits MULTIBRANCHES  
 (54) Title: METHOD AND SYSTEM FOR LINING MULTILATERAL WELLS



(57) **Abrégé/Abstract:**

In accordance with one embodiment of the present invention, a method for lining a lateral wellbore includes drilling a main wellbore extending from a surface to a subterranean zone, casing the main wellbore with a main casing having a plurality of lateral wellbore windows formed therein, positioning a whipstock having a longitudinal bore running therethrough adjacent a respective one of the lateral wellbore windows, forming a lateral wellbore through the respective lateral wellbore window using the whipstock, lining the first lateral wellbore with a lateral liner and a portion of a tie-back assembly that has a pre-milled lateral wellbore window formed therein, aligning the pre-milled lateral wellbore window with the longitudinal bore, and coupling the tie-back assembly to the main casing.

**ABSTRACT OF THE DISCLOSURE**

In accordance with one embodiment of the present invention, a method for lining a lateral wellbore includes drilling a main wellbore extending from a surface to a subterranean zone, casing the main wellbore with a main casing having a plurality of lateral wellbore windows formed therein, positioning a whipstock having a longitudinal bore running therethrough adjacent a respective one of the lateral wellbore windows, forming a lateral wellbore through the respective lateral wellbore window using the whipstock, lining the first lateral wellbore with a lateral liner and a portion of a tie-back assembly that has a pre-milled lateral wellbore window formed therein, aligning the pre-milled lateral wellbore window with the longitudinal bore, and coupling the tie-back assembly to the main casing.

067083.0308

1

METHOD AND SYSTEM FOR LINING MULTILATERAL WELLS

TECHNICAL FIELD OF THE INVENTION

The present invention relates generally to accessing a subterranean zone from the surface for production and/or injection of gas or other fluids and, more particularly, to a method and system for lining multilateral wells.

5

067083.0308

2

BACKGROUND OF THE INVENTION

Subterranean deposits of coal, shale and other formations often contain substantial quantities of methane gas. Vertical wells and vertical well patterns have been used to access coal and shale formations to produce the methane gas. More recently, horizontal patterns and interconnected wellbores have also been used to produce methane gas from coal and shale formations and/or to sequester carbon dioxide. Limited production and use of methane gas from such formations has occurred for many years because substantial obstacles have frustrated extensive development and use of methane gas deposits in coal seams.

One such obstacle is the potential for collapse of the wellbore(s) during the production of the methane gas. A solution to this problem is to run casing/liners in the producing zone. A casing with properly sized openings prevents the collapsed coal from plugging the hole, which would prevent optimum production. The use of multiple wellbores from the same parent well also improve production, but this creates a new set of obstacles. A junction must be made between the main wellbore and the respective lateral wellbores. If solids production (coal) is anticipated this junction should allow access to both the lateral and the main wellbore below the lateral for clean out purposes, which can create obstacles in the completion

067083.0308

3

SUMMARY OF THE INVENTION

In accordance with one embodiment of the present invention, a method for lining a lateral wellbore includes drilling a main wellbore extending from a surface to a subterranean zone, casing the main wellbore with a main casing having a plurality of lateral wellbore windows formed therein, positioning a whipstock having a longitudinal bore running therethrough adjacent a respective one of the lateral wellbore windows, forming a lateral wellbore through the respective lateral wellbore window using the whipstock, lining the first lateral wellbore with a lateral liner and a portion of a tie-back assembly that has a pre-milled lateral wellbore window formed therein, aligning the pre-milled lateral wellbore window with the longitudinal bore, and coupling the tie-back assembly to the main casing.

In accordance with another embodiment of the present invention, a system for lining a lateral wellbore includes a main casing having a lateral wellbore window formed therein disposed within a main wellbore and a whipstock having a longitudinal bore running therethrough and disposed within the main wellbore adjacent the lateral wellbore window. The whipstock includes a deflecting surface for forming a lateral wellbore through the lateral wellbore window. The system further includes a tie-back assembly operable to dispose a lateral liner within the lateral wellbore. The tie-back assembly has a tie-back window formed therein, whereby when the tie-back assembly is disposed into the main wellbore, the lateral liner and a portion of the tie-back assembly are deflected into the lateral wellbore by the deflecting surface such that the tie-back window aligns with the longitudinal bore of the whipstock.

Technical advantages of one or more embodiments may include more cost-effective tie-back systems that provide increased strength against collapse of a lateral wellbore junction. In one embodiment, a tie-back system allows a 4 3/4" lateral wellbore to be drilled through a window in a 5 1/2" casing and subsequently cased with a liner having a uniform outside diameter that is only slightly less than 4 3/4". In this embodiment, a whipstock that is used to drill and case the lateral includes a latching mechanism that mechanically couples the tie-back assembly thereto. The whipstock may also include a concentric bore therethrough to allow tools to more easily pass through for coal dust removal or other well treatment operations. Further,

067083.0308

4

this embodiment eliminates the need for an additional whipstock to be used to enter the lateral wellbore, which saves time and costs by avoiding additional trips into the well.

5 In certain embodiments, a tie-back system having a pre-milled window aligns with the bore in the whipstock to allow access to the main wellbore past the whipstock as the tie-back system is being placed. The tie-back system includes a swivel that allows angular misalignment, but not rotational misalignment, in order to align the window to the bore. A latching system at the end of the tie-back system and the casing liner mechanically locks the tie-back system in place. In this embodiment,  
10 the whipstock stays in place and, consequently, no additional whipstock is needed to enter the lateral wellbore, which saves a trip into the well.

The above and elsewhere described technical advantages may be provided and/or evidenced by some, all or none of the various embodiments. In addition, other technical advantages may be readily apparent from the following figures, descriptions,  
15 and claims.

067083.0308

5

BRIEF DESCRIPTION OF THE DRAWINGS

FIGURE 1 is a plan diagram illustrating a pinnate drainage pattern for accessing deposits in a subterranean zone in accordance with one embodiment of the invention;

5 FIGURE 2 is a cross-sectional view of a whipstock disposed within a portion of a main wellbore, and a lateral wellbore drilled using the whipstock according to one embodiment of the invention;

FIGURE 3 is a cross-sectional view of a tie-back assembly disposed within another portion of the main wellbore of FIGURE 2 according to one embodiment of  
10 the invention;

FIGURE 4 is a cross-sectional view illustrating the installation of the tie-back assembly of FIGURE 3 within the main wellbore proximate the whipstock according to one embodiment of the invention;

FIGURE 5 is a cross-sectional view of a tie-back assembly disposed within the  
15 portion of the main wellbore of FIGURE 2 according to another embodiment of the invention;

FIGURE 6 is a cross-sectional view illustrating the installation of the tie-back assembly of FIGURE 5 within the main wellbore proximate the whipstock according to another embodiment of the invention; and

20 FIGURE 7 is a flowchart illustrating a method of lining a lateral wellbore according to one embodiment of the invention.

067083.0308

6

DETAILED DESCRIPTION OF THE INVENTION

FIGURE 1 is a plan diagram illustrating a pinnate drainage pattern 100 for accessing deposits in a coal seam or other suitable subterranean zone in accordance with one embodiment of the invention. In the illustrated embodiment, pinnate drainage pattern 100 comprises a vertical wellbore 101 extending from a surface down to a main wellbore 102 disposed within a subterranean zone, and a plurality of lateral wellbores 104 extending from main wellbore 102. Although drainage pattern 100 is in the form of a pinnate pattern, the present invention contemplates other suitable drainage patterns for use within the teachings of the present invention. Vertical wellbore 101, main wellbore 102, and lateral wellbores 104 may be formed using any suitable drilling techniques and may be formed with any suitable diameters and lengths.

The drilling of lateral wellbores 104 from main wellbore 102 result in a plurality of wellbore junctions 106. Because the angles of lateral wellbores 104 with respect to main wellbore 102 is typically no more than approximately ten degrees, problems may arise with regard to the collapsing of wellbore junctions 106, especially in subterranean formations such as coal seams. In order to minimize the potential problems of collapsing of wellbore junctions 106, wellbore junctions 106 may be lined with tie-back assemblies when lining lateral wellbores 104. Two such tie-back assemblies for supporting a particular wellbore junction 106 are shown and described below in conjunction with FIGURES 3 through 4 and FIGURES 5 through 6, respectively. An example wellbore junction 106 is illustrated below in conjunction with FIGURE 2.

FIGURE 2 is a cross-sectional view of an example wellbore junction 106 according to one embodiment of the invention. As illustrated in FIGURE 2, a main casing 202 is utilized to line main wellbore 102 using any suitable casing techniques well known in the industry. Main casing 202 may be a perforated liner, a slotted liner, or other suitable liner. In one embodiment, main casing 202 includes an outside diameter of approximately five and one-half inches; however, other suitable diameters may be utilized for main casing 202. Main casing 202 includes a plurality of lateral wellbore windows 203 (only one of which is shown in FIGURE 2) that may be pre-milled before or milled after main casing 202 is disposed within main wellbore 102.

067083.0308

7

Lateral wellbore window 203 functions to allow lateral wellbore 104 to be drilled off of main wellbore 102. In order to drill lateral wellbore 104, a whipstock 200 is disposed within main casing 202 adjacent wellbore junction 106. Whipstock 200 may be positioned adjacent wellbore junction 106 using any suitable method. In addition, whipstock 200 may be coupled to main casing 202 using any suitable method, such as a suitable latching mechanism 204. Latching mechanism 204 may also function to align whipstock 200 in such a manner that a deflecting surface 206 of whipstock 200 is suitably positioned within main casing 202 in order to adequately direct a drill bit or other suitable drilling mechanism through lateral wellbore window 203 in order to drill lateral wellbore 104. In one embodiment, deflecting surface 206 extends around the full perimeter of whipstock 200. In the illustrated embodiment, lateral wellbore 104 includes a diameter of approximately four and three-quarter inches; however, other suitable diameters are contemplated by the present invention.

In particular embodiments, whipstock 200 includes a longitudinal bore 208 running therethrough that functions to allow access to main wellbore 102 below whipstock 200. Longitudinal bore 208 may or may not be concentric with an outside diameter of whipstock 200. Although longitudinal bore 208 may have any suitable diameter, in one embodiment a diameter 209 of longitudinal bore 208 is approximately 2.44 inches. Whipstock 200 may be suitably positioned within main casing 202 using any suitable techniques. In situations where lateral wellbore 104 is the farthest lateral wellbore 104 from vertical wellbore 101 (FIGURE 1), whipstock 200 may be run-in-place. Lateral wellbore 104 is then ready to be drilled and then lined and wellbore junction 106 is ready to be otherwise completed with a suitable tie-back assembly. One such system for facilitating these operations is described below in conjunction with FIGURES 3 and 4.

FIGURE 3 is a cross-sectional view of a tie-back assembly 300 disposed within main casing 202 at a location within main wellbore 102 away from wellbore junction 106 according to one embodiment of the invention. Tie-back assembly 300, which may be formed from one or more circular tubes or other suitable hollow structures, may be run-in-hole using any suitable method. In the illustrated embodiment, a running tool 302 using any suitable locking mechanism 303 is utilized to run tie-back assembly 300 and lateral liner 304 down through main casing 202. As

067083.0308

8

described above, tie-back assembly 300 is utilized to line lateral wellbore 104 with a lateral liner 304 and to provide collapse resistance for wellbore junction 106 (FIGURE 2). In the illustrated embodiment, tie-back assembly 300 includes a lower section 308, an upper section 310, and an intermediate section 312 disposed between  
5 lower section 308 and upper section 310.

Lower section 308 couples to lateral liner 304 via a tube coupling 306 or other suitable coupling. In an embodiment where lateral wellbore 104 has a diameter of approximately four and three-quarters inches, lateral liner 304 includes an outside diameter of approximately two and seven-eighths inches. However, other suitable  
10 diameters may be utilized for lateral liner 304. In another embodiment, a three and one-half inch outside diameter lateral liner 304 is utilized. Although lower section 308 may have any suitable diameter, it is preferable that lower section 308 have a diameter that substantially matches a diameter of lateral liner 304.

Intermediate section 312 includes a tie-back window 314 formed therein that  
15 aligns with longitudinal bore 208 of whipstock 200 (FIGURE 2) when tie-back assembly 300 is fully installed. This is described in more detail below in conjunction with FIGURE 4. Tie-back window 314 may have any suitable shape and any suitable dimensions; however, in order for tie-back window 314 to align with longitudinal bore 208 to allow access past whipstock 200 (FIGURE 2), tie-back window 314 is  
20 generally oval-shaped. Intermediate section 312 may have any suitable length and any suitable diameter. In one embodiment, intermediate section 312 includes a diameter that gradually decreases from upper section 310 to lower section 308. In addition, intermediate section 312 may have any suitable configuration. For example, as illustrated by dashed line 315, intermediate section 312 may be cylindrically  
25 shaped so as to allow lateral liner 304, lower section 308, and a portion of intermediate section 312 to enter lateral wellbore 104 more easily.

Intermediate section 312 may couple to lower section 308 using any suitable method; however, in the illustrated embodiment, a lower swivel 316 functions to couple intermediate section 312 to lower section 308. Lower swivel 316, in one  
30 embodiment, functions to allow angular and rotational movement of intermediate section 312 relative to lower section 308. This facilitates lateral liner 304 staying

067083.0308

9

substantially stationary within lateral wellbore 104 as intermediate section 312 is either rotated and/or angled in some manner.

Upper section 310 couples to intermediate section 312 in any suitable manner; however, in the illustrated embodiment, an upper swivel 318 is utilized. Upper swivel 318, in one embodiment, allows only angular movement of intermediate section 312 relative to upper section 310. Therefore, when upper section 310 is rotated, then intermediate section 312 is also rotated. However, when intermediate section 312 is angled in some manner, then upper section 310 remains in substantially the same position. Upper section 312 may have any suitable diameter and any suitable length. In one embodiment, upper section 310 includes an outside diameter of approximately four and a half inches so that it may fit within a five and one-half inches diameter main casing 202.

FIGURE 4 is a cross-sectional view of a particular wellbore junction 106 illustrating the installation of tie-back assembly 300 according to one embodiment of the invention. As illustrated, lateral liner 304 is disposed within lateral wellbore 104. The insertion of lateral liner 304 within lateral wellbore 104 is facilitated by deflecting surface 206 of whipstock 200. Briefly, an end (not explicitly shown) of lateral liner 304 engages deflecting surface 206 of whipstock 200 and is deflected through lateral wellbore window 203 and into lateral wellbore 104. In one embodiment, this is facilitated by having the end of lateral liner 304 with an outside diameter that is at least slightly greater than the diameter of longitudinal bore 208. This assures the correct deflection of lateral liner 304 through lateral wellbore window 203. In one embodiment, the end of lateral liner 304 includes a suitable cap, such as a bullnose, to facilitate the guiding of lateral liner 304 into lateral wellbore 104. Because lateral liner 304 is typically very long, lateral liner 304 is formed from a material that allows some flexing of lateral liner 304 as it is being installed into lateral wellbore 104. As tie-back assembly 300 approaches wellbore junction 106, lower swivel 316 allows for any angular misalignment between lower section 308 and intermediate section 312 of tie-back assembly 300.

A portion of tie-back assembly 300 is also inserted through lateral wellbore window 203 and into lateral wellbore 104. Tie-back assembly 300 is fully installed when tie-back window 314 of intermediate portion 312 aligns with longitudinal bore

067083.0308

10

208 of whipstock 200 as illustrated. The running tool 302 that is installing tie-back assembly 300 may have to be rotated in order to align tie-back window 314 with longitudinal bore 208. In other embodiments, a muleshoe-type device may provide rotation and alignment. Although any suitable alignment technique may be utilized, a latching mechanism 400 may be utilized to help align tie-back window 314 with longitudinal bore 208 in addition to coupling upper section 310 to main casing 202. Any suitable latching mechanism may be utilized. Because upper swivel 318 allows only angular movement of intermediate section 312 relative to upper section 310, intermediate section 312 is also rotated when upper section 310 is rotated by running tool 302 or a muleshoe-type sleeve. This helps to align tie-back window 314 with longitudinal bore 208. Any gap resulting after the installation of tie-back assembly 300 due to lateral wellbore window 203 may be covered with any suitable closing gate (not shown).

Thus, the alignment of tie-back window 314 with longitudinal bore 208 allows access to main wellbore 102 below whipstock 200. Tools may then be run through longitudinal bore 208 to perform any suitable operation to main wellbore 102 below whipstock 200, such as the removing of coal seam dust.

Although FIGURES 3 through 4 illustrate the lining of a particular lateral wellbore 104 and completion of its respective wellbore junction 106, the other remaining lateral wellbores 104 and wellbore junctions 106 (see FIGURE 1) are lined and completed in a similar manner as illustrated in FIGURES 3 and 4. The sequence of lining operations according to one embodiment is to start with the lateral wellbore 104 that is farthest from the surface and work backwards towards the surface. Because whipstocks 200 are left in place, they may be utilized to re-enter any of the lateral wellbores 104 in order to form any operations within a respective lateral wellbore 104. This eliminates having to install an additional whipstock into main casing 202, which saves a trip into the well. Another system for facilitating the lining of lateral wellbores 104 and completing of wellbore junctions 106 is described below in conjunction with FIGURES 5 and 6.

FIGURE 5 is a cross-sectional view of a tie-back assembly 500 disposed within main casing 202 according to another embodiment of the invention. Tie-back assembly 500, which may be formed from one or more circular tubes or other suitable

067083.0308

11

hollow structures, may be run-in-hole using any suitable method, such as a running tool and suitable locking mechanism as described above. Tie-back assembly 500 is utilized to line a particular lateral wellbore 104 with a lateral liner 504 and to provide collapse resistance for its associated wellbore junction 106 (FIGURE 2). In the  
5 illustrated embodiment, tie-back assembly 500 includes a lower section 508, an upper section 510, an intermediate section 512 disposed between lower section 508 and upper section 510, and a nose section 513 coupled to intermediate section 512.

Lower section 508 couples to lateral liner 504 via a tube coupling 506 or other suitable coupling. In an embodiment where lateral wellbore 104 has a diameter of  
10 approximately four and three-quarters inches, lateral liner 504 includes an outside diameter of approximately two and seven-eighths inches. However, other suitable diameters may be utilized for lateral liner 504. In another embodiment, a three and one-half inch outside diameter lateral liner 504 is utilized. Although lower section 508 may have any suitable diameter, it is preferable that lower section 508 have a  
15 diameter that substantially matches a diameter of lateral liner 504.

Intermediate section 512 includes a tie-back window 514 formed therein that is aligned with a bore 515 of nose section 513. Therefore, when tie-back assembly 500 is fully installed, tie-back window 514 and bore 515 of nose section 513 align with longitudinal bore 208 of whipstock 200 (FIGURE 2). This is illustrated best in  
20 FIGURE 6. Tie-back window 514 may have any suitable shape and any suitable dimensions; however, because intermediate section 512 is angled with respect to bore 515, tie-back window 514 is generally oval-shaped. Intermediate section 512 may have any suitable length and any suitable diameter. Because nose section is coupled to intermediate section 512 and fits within longitudinal bore 208 (as described below),  
25 intermediate section 512 includes a diameter that gradually decreases from upper section 510 to lower section 508.

Nose section 513 couples to intermediate section 512 in any suitable manner. In addition, nose section 513 may have any suitable length and diameter. However, since nose section 513 is disposed within longitudinal bore 208 of whipstock 200  
30 when tie-back assembly is fully installed, nose section 513 typically has a length shorter than the length of whipstock 200 and an outside diameter equal to or slightly less than the diameter of longitudinal bore 208. Nose section 513 functions to provide

067083.0308

12

additional collapse resistance to wellbore junction 106 and to help align tie-back assembly 500 when being installed.

Intermediate section 512 may couple to lower section 508 using any suitable method; however, in the illustrated embodiment, a lower swivel 516 functions to  
5 couple intermediate section 512 to lower section 508. Lower swivel 516, in one embodiment, functions to allow angular and rotational movement of intermediate section 512 relative to lower section 508. This facilitates lateral liner 504 staying substantially stationary within lateral wellbore 104 as intermediate section 512 is either rotated and/or angled in some manner.

10 Upper section 510 couples to intermediate section 512 in any suitable manner; however, in the illustrated embodiment, an upper swivel 518 is utilized. Upper swivel 518, in one embodiment, allows only angular movement of intermediate section 512 relative to upper section 510. Therefore, when upper section 510 is rotated, then intermediate section 512 is also rotated. However, when intermediate section 512 is  
15 angled in some manner, then upper section 510 remains in substantially the same position. Upper section 512 may have any suitable diameter and any suitable length. In one embodiment, upper section 510 includes an outside diameter of approximately four and a half inches so that it may fit within a five and one-half inches diameter main casing 202.

20 FIGURE 6 is a cross-sectional view of a particular wellbore junction 106 illustrating the installation of tie-back assembly 500 according to one embodiment of the invention. As illustrated, lateral liner 504 is disposed within lateral wellbore 104. The insertion of lateral liner 504 within lateral wellbore 104 is facilitated by deflecting surface 206 of whipstock 200. Briefly, an end (not explicitly shown) of  
25 lateral liner 504 engages deflecting surface 206 of whipstock 200 and is deflected through lateral wellbore window 203 and into lateral wellbore 104. In one embodiment, this is facilitated by having the end of lateral liner 504 with an outside diameter that is at least slightly greater than the diameter of longitudinal bore 208. This assures the correct deflection of lateral liner 504 through lateral wellbore  
30 window 203. In one embodiment, the end of lateral liner 504 includes a suitable cap, such as a bullnose, to facilitate the guiding of lateral liner 504 into lateral wellbore 104. Because lateral liner 504 is typically very long, lateral liner 504 is formed from

067083.0308

a material that allows some flexing of lateral liner 504 as it is being installed into lateral wellbore 104. As tie-back assembly 500 approaches wellbore junction 106, lower swivel 516 allows for any angular misalignment between lower section 508 and intermediate section 512 of tie-back assembly 500.

5 A portion of tie-back assembly 500 is also inserted through lateral wellbore window 203 and into lateral wellbore 104. Tie-back assembly 500 is fully installed when nose section 513 is inserted into longitudinal bore 208 of whipstock 200 as illustrated. The running tool that is installing tie-back assembly 500 may have to be rotated slightly in order to align tie-back window 514 with longitudinal bore 208. A  
10 latching mechanism 400 may be utilized to couple upper section 510 to main casing 202. Any suitable latching mechanism may be utilized. Because upper swivel 518 allows only angular movement of intermediate section 512 relative to upper section 510, intermediate section 512 is also rotated when upper section 510 is rotated by running tool 502 or a muleshoe sleeve type device. This helps to align nose section  
15 513 with longitudinal bore 208. Any gap resulting after the installation of tie-back assembly 500 due to lateral wellbore window 203 may be covered with any suitable closing gate (not shown).

Thus, the alignment of tie-back window 514 and nose section 513 with longitudinal bore 208 allows access to main wellbore 102 below whipstock 200.  
20 Tools may then be run through nose section 513 and longitudinal bore 208 to perform any suitable operation to main wellbore 102 below whipstock 200, such as the removing of coal seam dust.

Although FIGURES 5 through 6 illustrate the lining of a particular lateral wellbore 104 and completion of its respective wellbore junction 106, the other  
25 remaining lateral wellbores 104 and wellbore junctions 106 (see FIGURE 1) are lined and completed in a similar manner as illustrated in FIGURES 5 and 6. Because whipstocks 200 are left in place, they may be utilized to re-enter any of the lateral wellbores 104 in order to form any operations within a respective lateral wellbore 104. This eliminates having to install an additional whipstock into main casing 202,  
30 which saves a trip into the well.

FIGURE 7 is a flowchart illustrating an example method of lining a lateral wellbore 104 according to one embodiment of the invention. The method begins at

067083.0308

14

step 700 where main wellbore 102 extending from a surface to a subterranean zone is drilled. As described above, any suitable drilling method may be utilized. Main wellbore 102 is cased with main casing 202 at step 702. Main casing 202 includes a plurality of lateral wellbore windows 203 formed therein that facilitate the drilling of a plurality of lateral wellbores 104 from main wellbore 102. In some embodiments, there may be an additional step (not illustrated) in which main wellbore 102 is cased with a string with no windows and then the main leg of the multilateral (near horizontal wellbore) is drilled in the subterranean zone and then cased with a casing that includes the window sections. This casing may not necessarily extend back to the surface but may overlap the first casing run from surface.

Whipstock 200 is positioned adjacent a respective one of the lateral wellbore windows 203 at step 704. As described above, whipstock 200 has longitudinal bore 208 running therethrough that allows access to main wellbore 102 below whipstock 200. Whipstock 200 may be positioned using any suitable method. A lateral wellbore 104 is formed through the respective lateral wellbore window 203, as denoted by step 706. This forms a wellbore junction 106.

Lateral wellbore 104 is then lined with a lateral liner and a portion of a tie-back assembly, as denoted by step 708. Examples of this lining step are described above in conjunction with FIGURES 3 through 4 and FIGURES 5 and 6. A tie-back window of the tie-back assembly is aligned with a longitudinal bore of the whipstock at step 710. This may include rotating portions of the tie-back assembly or other suitable manipulation in order to facilitate the aligning. The tie-back assembly is then coupled to a main casing with a suitable latching mechanism at step 712. The positioning of the whipstock, forming of lateral wellbore 104, lining of lateral wellbore 104, aligning of the tie-back window with the longitudinal bore, and coupling of a tie-back assembly to the main casing is then repeated for each additional lateral wellbore window formed in the main casing, as denoted by step 714. The pinnate drainage pattern 100 is then ready for subsequent production or other suitable operation. That ends the example method as illustrated in FIGURE 7.

Although the present invention has been described with several embodiments, various changes and modifications may be suggested to one skilled in the art. It is

067083.0308

15

intended that the present invention encompass such changes and modifications as fall within the scope of the appended claims and their equivalence.

**CLAIMS**

1. A system for lining a lateral wellbore, comprising:
  - a main casing having a lateral wellbore window formed therein disposed within a main wellbore;
  - 5 a whipstock having a longitudinal bore running therethrough and disposed within the main wellbore adjacent the lateral wellbore window, the whipstock comprising a deflecting surface for forming a lateral wellbore through the lateral wellbore window;
  - a tie-back assembly operable to dispose a lateral liner within the lateral wellbore, the tie-back assembly having a tie-back window formed therein;
  - 10 a latch mechanism operable to couple the tie-back assembly directly to the main casing and align the tie-back window with the longitudinal bore of the whipstock;
  - whereby, when the tie-back assembly is disposed into the main wellbore, the lateral liner and a portion of the tie-back assembly are deflected into the lateral wellbore by the deflecting surface such that the tie-back window aligns with the longitudinal bore of the whipstock.
2. The system of Claim 1, further comprising a latching mechanism operable to couple the whipstock to an inside surface of the main casing and align the deflecting surface with the lateral wellbore window.
- 20 3. The system of Claim 1, wherein the longitudinal bore of the whipstock is concentric with an outside diameter of the whipstock.
4. The system of Claim 1, wherein the tie-back assembly comprises:
  - a lower section configured to couple to the lateral liner;
  - 25 an upper section configured to couple to the main casing; and
  - an intermediate section disposed between the lower and upper sections;

a first swivel coupling the intermediate section to the lower section, the first swivel operable to allow angular and rotational movement of the intermediate section relative to the lower section; and

5 a second swivel coupling the intermediate section to the upper section, the second swivel operable to allow only angular movement of the intermediate section relative to the upper section.

5. The system of Claim 1, wherein the deflecting surface extends around the full perimeter of the whipstock.

6. The system of Claim 1, wherein an end of the lateral liner comprises an  
10 outside diameter that is at least slightly greater than a diameter of the longitudinal bore.

7. The system of Claim 1, wherein the main casing comprises an outside diameter of approximately 5 1/2 inches.

8. A method for lining a lateral wellbore, comprising:  
15 drilling a main wellbore extending from a surface to a subterranean zone;  
casing the main wellbore with a main casing having a plurality of lateral wellbore windows formed therein;

positioning a whipstock having a longitudinal bore running therethrough adjacent a respective one of the lateral wellbore windows;

20 forming a lateral wellbore through the respective lateral wellbore window using the whipstock;

lining a first lateral wellbore with a lateral liner and a portion of a tie-back assembly, the tie-back assembly having a tie-back window formed therein;

aligning the tie-back window with the longitudinal bore; and

25 coupling the tie-back assembly to the main casing by engaging a latching mechanism that is operable to couple the tie-back assembly directly to the main casing and align the tie-back window with the longitudinal bore of the whipstock.

9. The method of Claim 8, further comprising successively repeating the positioning, forming, lining, aligning and coupling steps with respect to the remaining lateral wellbore windows.
10. The method of Claim 8, further comprising directing a tool through the lateral wellbore by utilizing the whipstock.
11. The method of Claim 8, wherein positioning the whipstock further comprises:  
aligning the whipstock such that a deflecting surface of the whipstock faces the respective lateral wellbore window.
12. The method of Claim 8, wherein aligning the tie-back window with the longitudinal bore further comprises rotating the tie-back assembly.
13. The method of Claim 8, wherein casing the main wellbore comprises casing the main wellbore with a main casing having an outside diameter of approximately 5 1/2 inches.
14. The method of Claim 8, wherein the tie-back assembly further comprises a lower section, an upper section, and an intermediate section disposed between the lower and upper sections, the method further comprising:  
allowing angular and rotational movement of the intermediate section relative to the lower section; and  
allowing only angular movement of the intermediate section relative to the upper section.
15. A system for lining a lateral wellbore, comprising:  
a main casing having a lateral wellbore window formed therein disposed within a main wellbore;  
a whipstock having a longitudinal bore running therethrough and disposed within the main wellbore adjacent the lateral wellbore window, the whipstock comprising a deflecting surface extending around the full perimeter of the whipstock for forming a lateral wellbore through the lateral wellbore window;

a tie-back assembly operable to dispose a lateral liner within the lateral wellbore, the tie-back assembly comprising:

a lower section configured to couple to the lateral liner;

an upper section;

5 an intermediate section disposed between the lower and upper sections, the intermediate section having a tie-back window formed therein; and

a nose section coupled to the intermediate section; and

whereby, when the tie-back assembly is disposed into the main wellbore, the lateral liner, the lower section and a portion of the intermediate section are deflected  
10 into the lateral wellbore by the deflecting surface and the nose section is inserted into the whipstock such that the tie-back window aligns with the longitudinal bore of the whipstock.

16. The system of Claim 15, wherein the longitudinal bore of the whipstock is concentric with an outside diameter of the whipstock.

15 17. The system of Claim 15, wherein the nose section is coupled to an inside surface of the whipstock with a latching mechanism.

18. The system of Claim 15, wherein a diameter of the intermediate section gradually decreases from the upper section to the lower section.

19. The system of Claim 15, wherein the main casing comprises an outside  
20 diameter of approximately 5 1/2 inches, the lateral wellbore comprises a diameter of approximately 4 3/4 inches, and a diameter of the intermediate section is uniform.

20. The system of Claim 15, wherein the whipstock comprises an outside diameter of approximately 4 1/2 inches and the longitudinal bore comprises a diameter of approximately 2.44 inches.

25 21. The system of Claim 15, further comprising a latching mechanism operable to couple the whipstock to an inside surface of the main casing and align the deflecting surface with the lateral wellbore window.

22. The system of Claim 15, further comprising:  
a first swivel coupling the intermediate section to the lower section, the first swivel operable to allow angular and rotational movement of the intermediate section relative to the lower section; and
- 5 a second swivel coupling the intermediate section to the upper section, the second swivel operable to allow only angular movement of the intermediate section relative to the upper section.
23. The system of Claim 15, further comprising a latching mechanism operable to couple the upper portion to the main casing.
- 10 24. The system of Claim 15, wherein an end of the lateral liner comprises an outside diameter that is at least slightly greater than a diameter of the longitudinal bore.
25. A method for lining a lateral wellbore, comprising:  
drilling a main wellbore extending from a surface to a subterranean zone;
- 15 casing the main wellbore with a main casing having a plurality of lateral wellbore windows formed therein;  
positioning a whipstock having a longitudinal bore running therethrough adjacent a respective one of the lateral wellbore windows, the whipstock comprising a deflecting surface extending around the full perimeter of the whipstock;
- 20 forming a lateral wellbore through the respective lateral wellbore window using the whipstock;  
lining a first lateral wellbore with a lateral liner and a portion of a tie-back assembly, the tie-back assembly comprising an intermediate section having a tie-back window formed therein;
- 25 aligning the tie-back window with the longitudinal bore; and  
coupling the tie-back assembly to the main casing.

26. The method of Claim 25, further comprising successively repeating the positioning, forming, lining, aligning and coupling steps with respect to the remaining lateral wellbore windows.

27. The method of Claim 25, further comprising directing a tool through the  
5 lateral wellbore by utilizing the whipstock.

28. The method of Claim 25, wherein the longitudinal bore of the whipstock is concentric with an outside diameter of the whipstock.

29. The method of Claim 25, wherein positioning the whipstock further comprises:

10 aligning the whipstock such that the deflecting surface of the whipstock faces the respective lateral wellbore window; and

coupling the whipstock to the main casing with a latching mechanism.

30. The method of Claim 25, wherein aligning the tie-back window with the longitudinal bore further comprises rotating the tie-back assembly and wherein  
15 coupling the tie-back assembly to the main casing comprises latching the tie-back assembly to the main casing.

31. The method of Claim 25, wherein the tie-back assembly further comprises a nose section, the method further comprising inserting substantially all of the nose section into the longitudinal bore of the whipstock when aligning the tie-back window  
20 with the longitudinal bore.

32. The method of Claim 25, wherein casing the main wellbore comprises casing the main wellbore with a main casing having an outside diameter of approximately 5 1/2 inches, and wherein forming the lateral wellbore comprises forming a lateral wellbore having an outside diameter of approximately 4 3/4 inches.

33. The method of Claim 25, wherein the tie-back assembly further comprises a lower section, an upper section, and a nose section, the method further comprising:

allowing angular and rotational movement of the intermediate section relative to the lower section; and

5 allowing only angular movement of the intermediate section relative to the upper section.

34. The method of Claim 33, further comprising causing a diameter of the intermediate portion to gradually decrease from the upper section to the lower section.

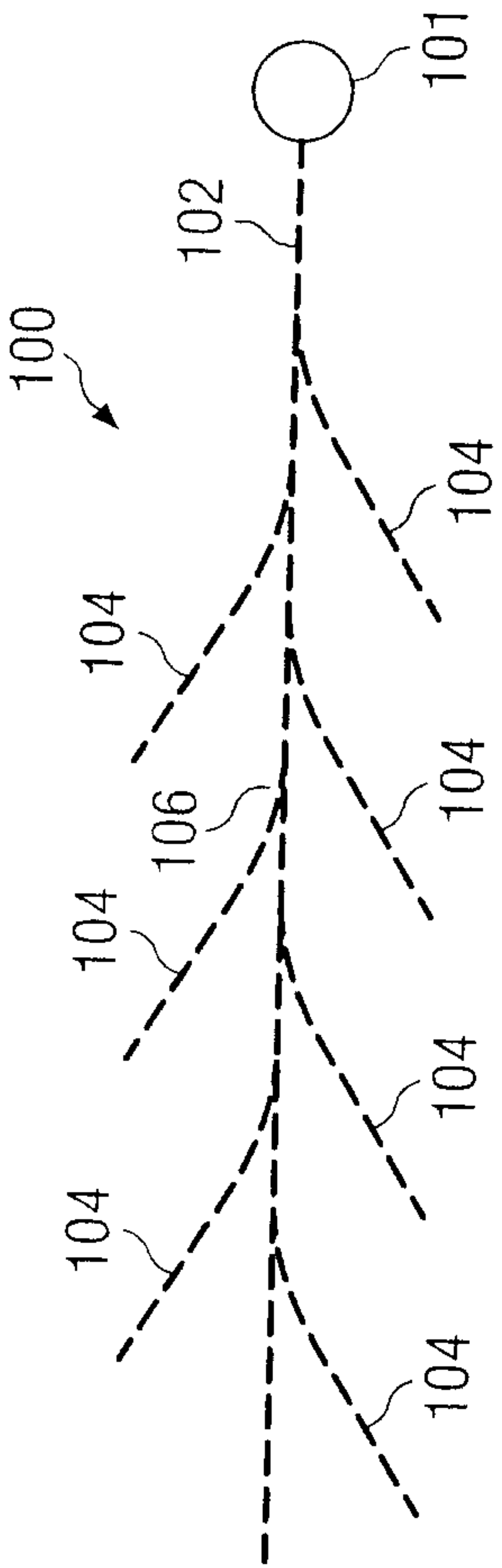

FIG. 1

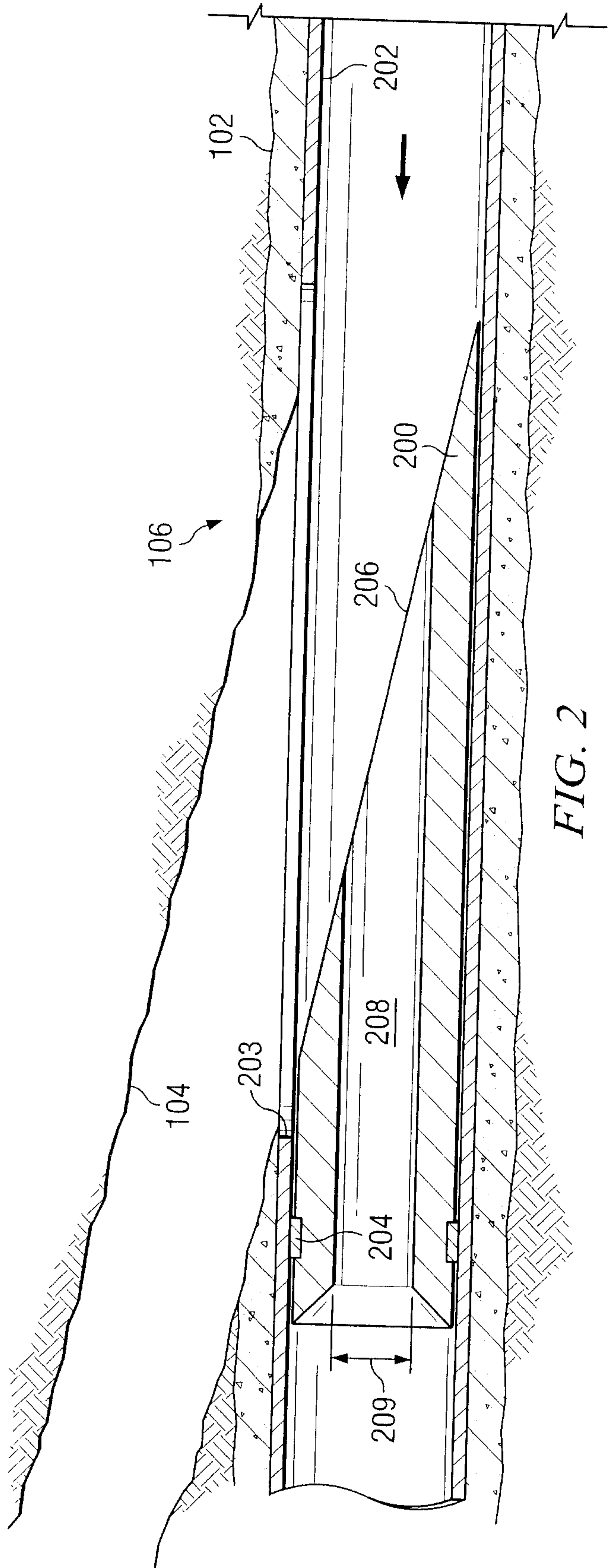

FIG. 2

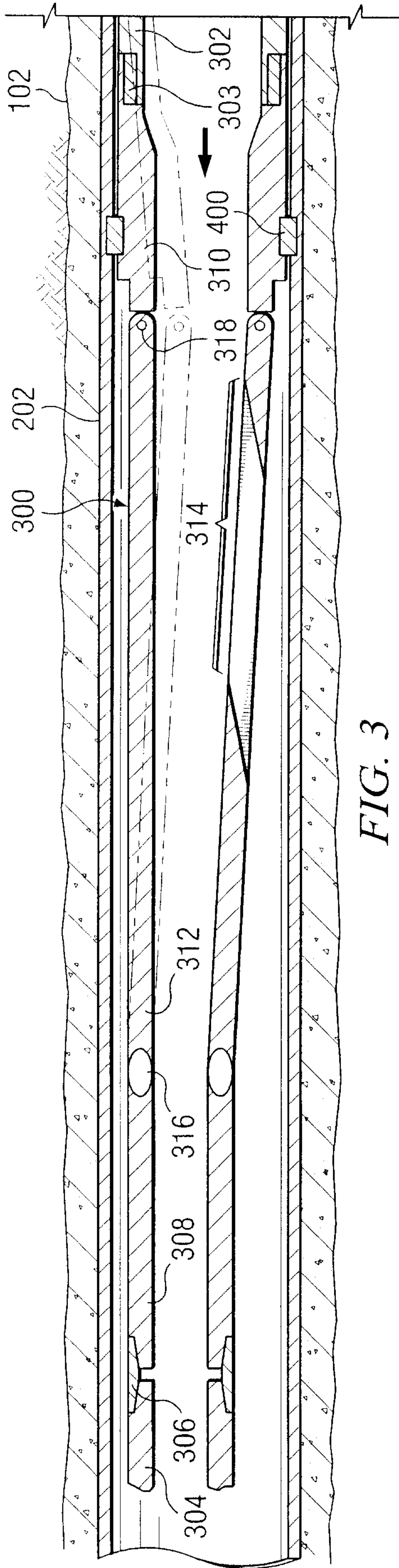

FIG. 3

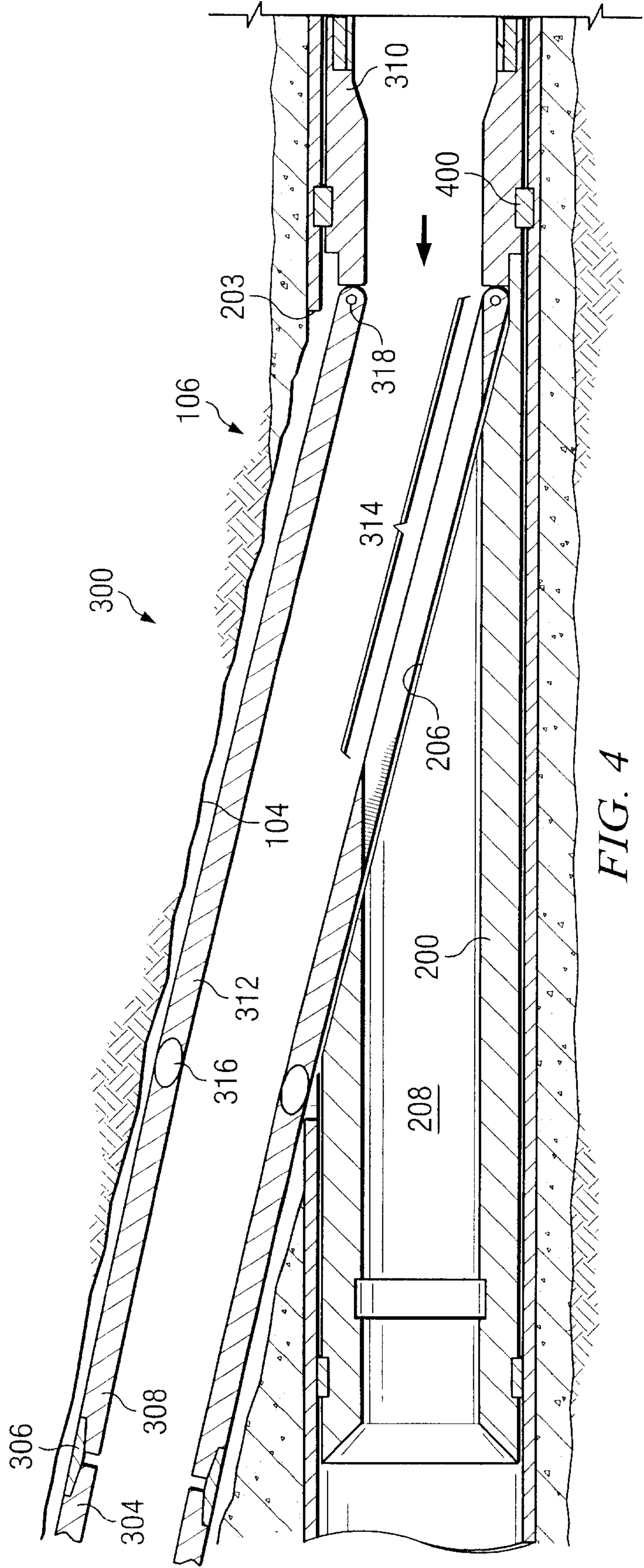

FIG. 4

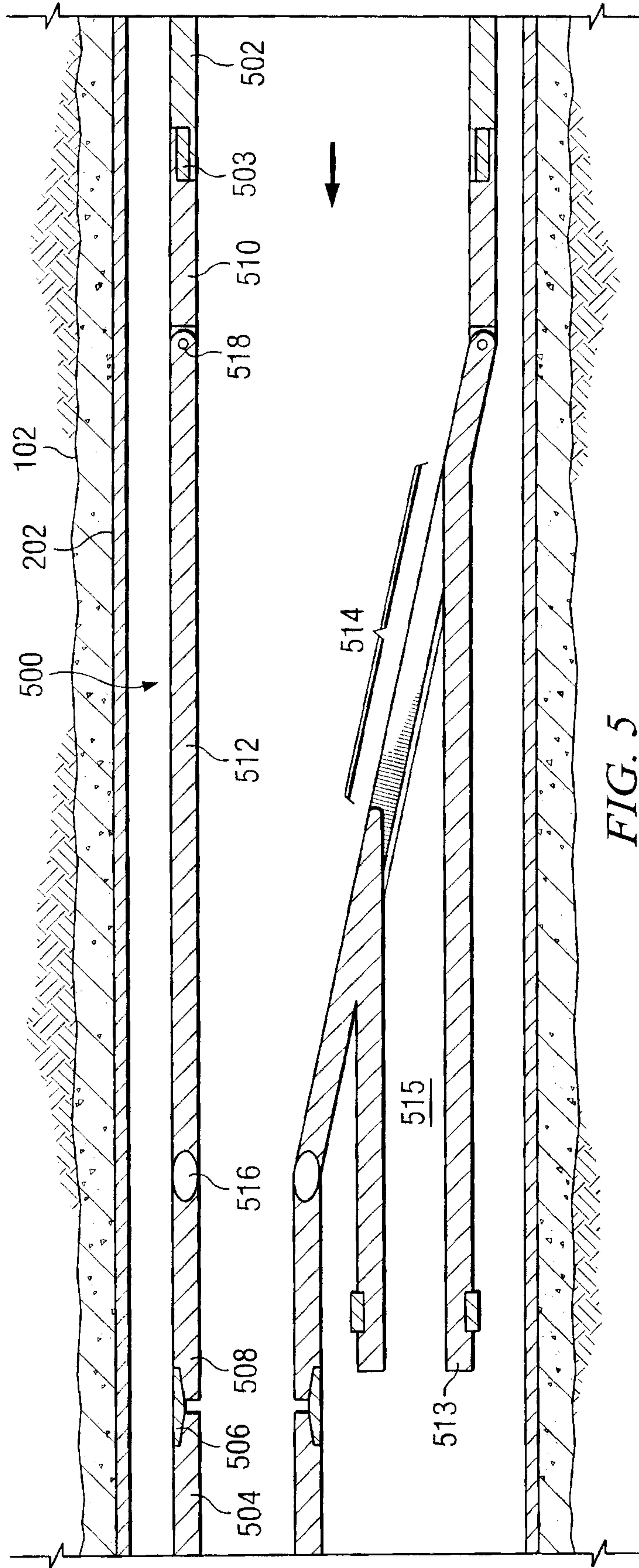

FIG. 5

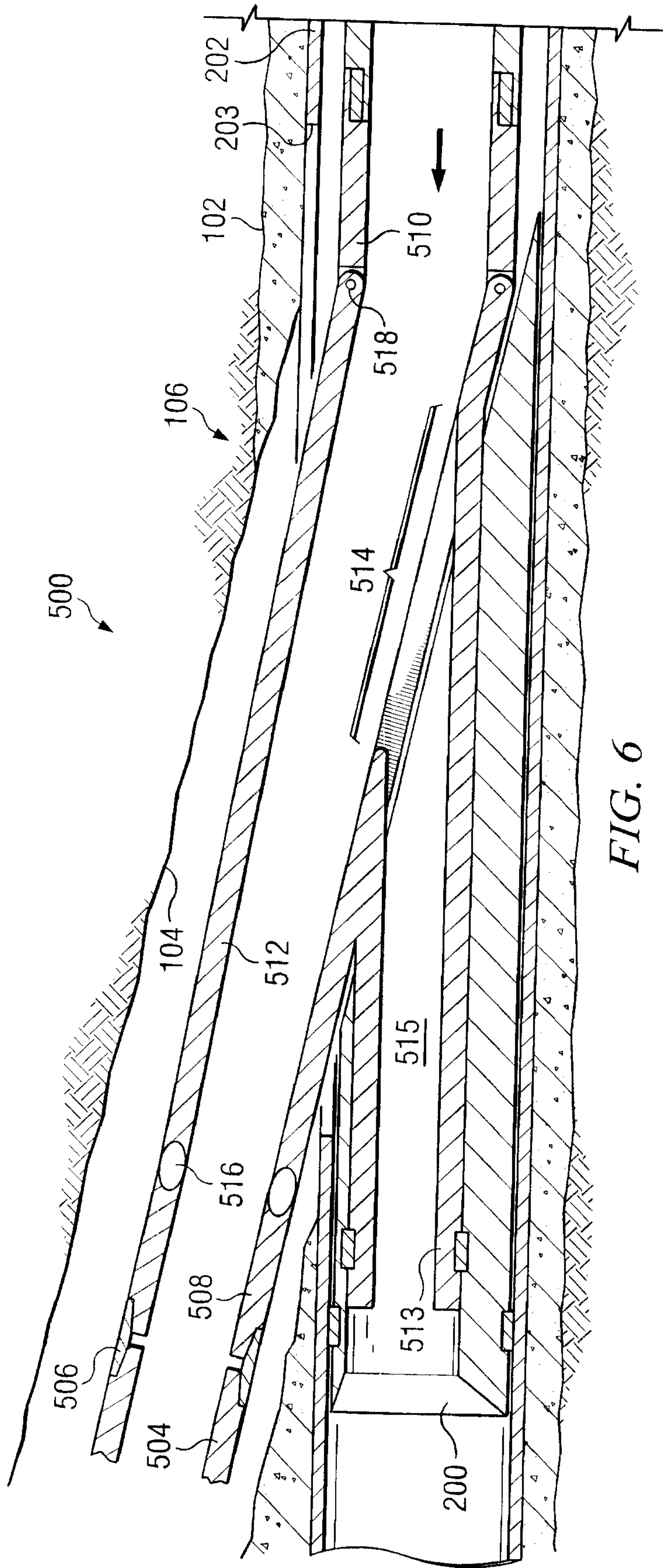

FIG. 6

5/5

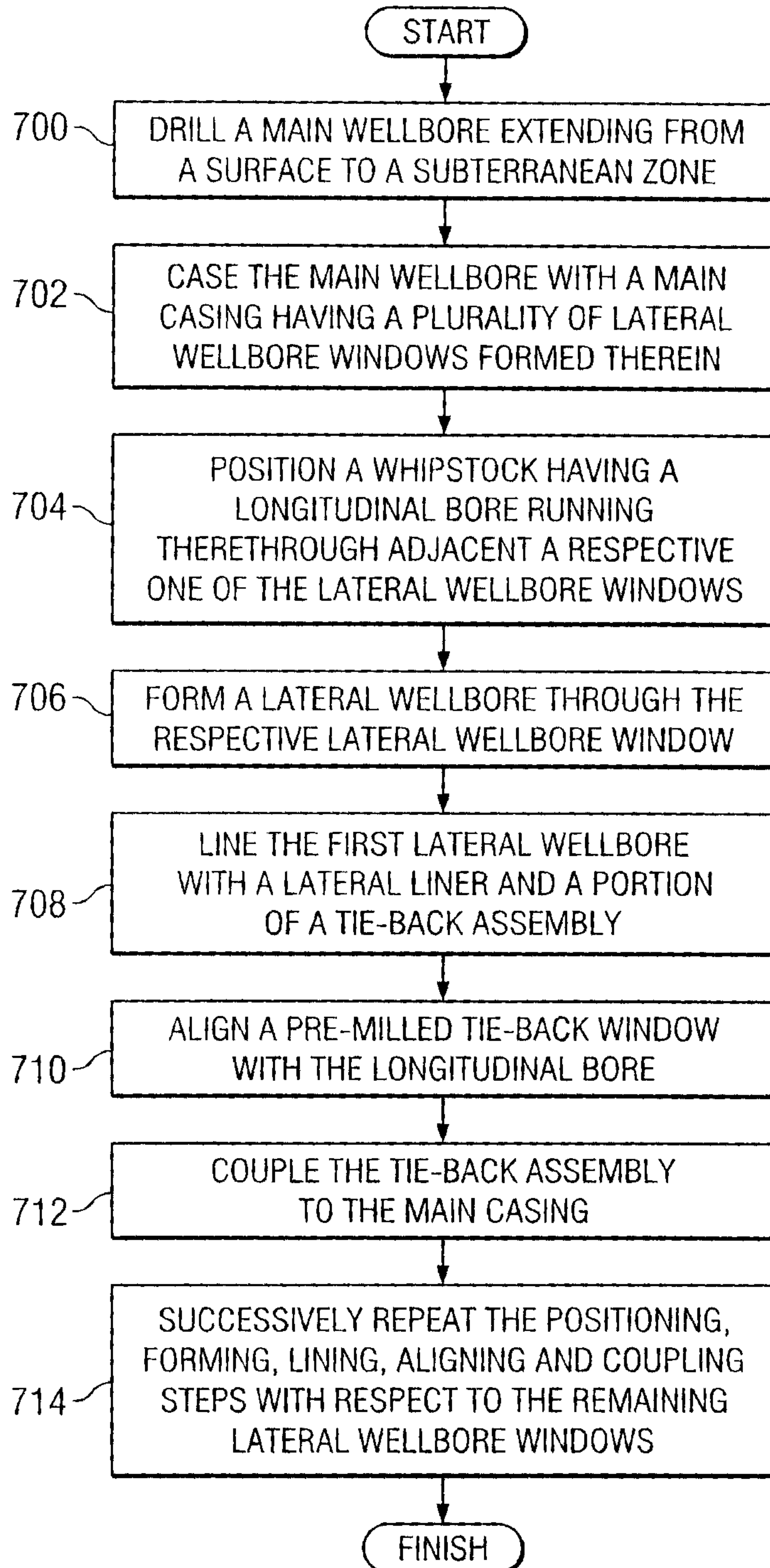

FIG. 7

