

INTERNATIONAL APPLICATION PUBLISHED UNDER THE PATENT COOPERATION TREATY (PCT)

| | | |
|---|---|--|
| (51) International Patent Classification ⁵ : H04R 5/02, 1/38 | A1 | (11) International Publication Number: WO 95/01078 |
| | | (43) International Publication Date: 5 January 1995 (05.01.95) |
| (21) International Application Number: PCT/US94/07020 | (81) Designated States: AM, AT, AU, BB, BG, BR, BY, CA, CH, CN, CZ, DE, DK, ES, FI, GB, GE, HU, JP, KE, KG, KP, KR, KZ, LK, LU, LV, MD, MG, MN, MW, NL, NO, NZ, PL, PT, RO, RU, SD, SE, SI, SK, TJ, TT, UA, UZ, VN, European patent (AT, BE, CH, DE, DK, ES, FR, GB, GR, IE, IT, LU, MC, NL, PT, SE), OAPI patent (BF, BJ, CF, CG, CI, CM, GA, GN, ML, MR, NE, SN, TD, TG). | |
| (22) International Filing Date: 22 June 1994 (22.06.94) | | |
| (30) Priority Data: 08/082,682 23 June 1993 (23.06.93) US | | |
| (71) Applicant: APPLE COMPUTER, INC. [US/US]; 20525 Mariani Avenue, Cupertino, CA 95014 (US). | | |
| (72) Inventors: LUNDGREN, David, A.; 316 Todd Way, Mill Valley, CA 94941 (US). OXFORD, William, V.; 919 Brentwood Drive, San Jose, CA 95129 (US). JOSEPHSON, David, L.; 3729 Corkerhill Way, San Jose, CA 95121 (US). | Published <i>With international search report.</i> <i>Before the expiration of the time limit for amending the claims and to be republished in the event of the receipt of amendments.</i> | |
| (74) Agents: SCHELLER, James, C. et al.; Blakely, Sokoloff, Taylor & Zafman, 7th floor, 12400 Wilshire Boulevard, Los Angeles, CA 90026 (US). | | |

(54) Title: COMPUTER VISUAL DISPLAY MONITOR WITH INTEGRAL STEREO SPEAKER AND DIRECTIONAL MICROPHONE AND METHOD FOR CONSTRUCTION

(57) Abstract

A high resolution computer visual display monitor employing a cathode ray tube (CRT) having a vertical aperture grill intended for personal computer systems and integrating a high quality stereophonic speaker system and a directional microphone, and methods for construction of same. The aperture grill has a natural frequency centered within the musical scale. The stereo speaker system comprises a ported speaker enclosure within which are mounted two conventional cone speaker assemblies. A stereo audio amplifier and control unit for controlling the audio signals delivered to the speakers is mounted within the speaker enclosure. The speaker enclosure is internally mounted within the monitor with a minimum number

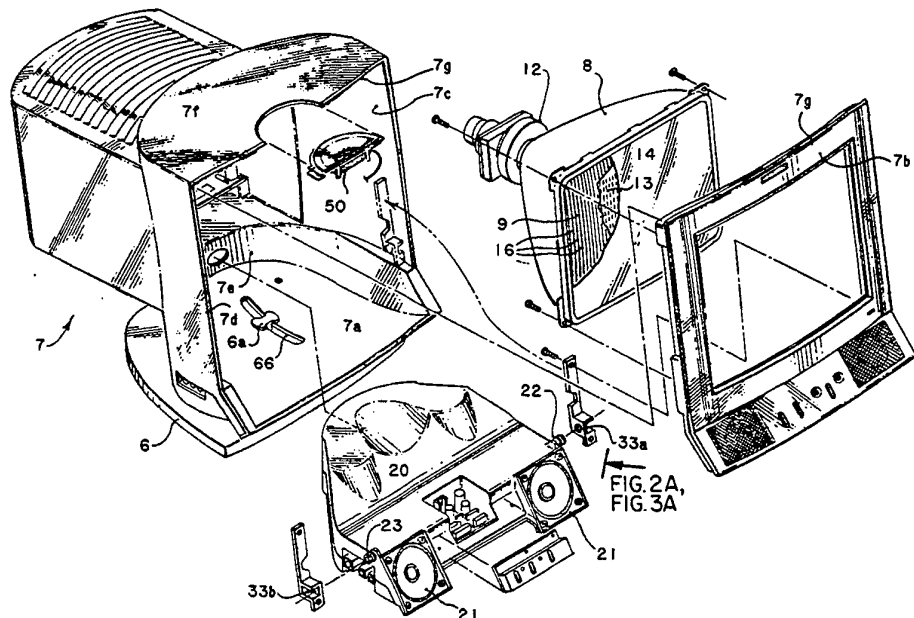

of attachment members incorporating vibration isolation material to remove vibration components near the natural frequency of the aperture grill. The speaker enclosure is internally reinforced to reduce structural deformations which contribute to airborne transmitted vibration within the monitor housing when the speaker system is operating. The integral directional microphone assembly comprises a cardioid electret microphone capsule retained therein by acoustically transparent foam. The microphone housing is mounted internally within the monitor housing facing the user and adjacent to the top surface of the monitor housing. The microphone housing comprises a frontal opening and a plurality of nonfrontally facing openings which together maximally preserve sound pressure gradient applied to the microphone capsule, thereby together with the mounting of said microphone housing on an exterior vertex of said monitor housing, resulting in a hypercardioid spatial response.

FOR THE PURPOSES OF INFORMATION ONLY

Codes used to identify States party to the PCT on the front pages of pamphlets publishing international applications under the PCT.

| | | | | | |
|----|--------------------------|----|--|----|--------------------------|
| AT | Austria | GB | United Kingdom | MR | Mauritania |
| AU | Australia | GE | Georgia | MW | Malawi |
| BB | Barbados | GN | Guinea | NE | Niger |
| BE | Belgium | GR | Greece | NL | Netherlands |
| BF | Burkina Faso | HU | Hungary | NO | Norway |
| BG | Bulgaria | IE | Ireland | NZ | New Zealand |
| BJ | Benin | IT | Italy | PL | Poland |
| BR | Brazil | JP | Japan | PT | Portugal |
| BY | Belarus | KE | Kenya | RO | Romania |
| CA | Canada | KG | Kyrgystan | RU | Russian Federation |
| CF | Central African Republic | KP | Democratic People's Republic of Korea | SD | Sudan |
| CG | Congo | KR | Republic of Korea | SE | Sweden |
| CH | Switzerland | KZ | Kazakhstan | SI | Slovenia |
| CI | Côte d'Ivoire | LI | Liechtenstein | SK | Slovakia |
| CM | Cameroon | LU | Luxembourg | SN | Senegal |
| CN | China | LK | Sri Lanka | TD | Chad |
| CS | Czechoslovakia | LV | Latvia | TG | Togo |
| CZ | Czech Republic | MC | Monaco | TJ | Tajikistan |
| DE | Germany | MD | Republic of Moldova | TT | Trinidad and Tobago |
| DK | Denmark | MG | Madagascar | UA | Ukraine |
| ES | Spain | ML | Mali | US | United States of America |
| FI | Finland | MN | Mongolia | UZ | Uzbekistan |
| FR | France | | | VN | Viet Nam |
| GA | Gabon | | | | |

**COMPUTER VISUAL DISPLAY MONITOR
WITH INTEGRAL STEREO SPEAKER AND DIRECTIONAL
MICROPHONE
AND METHOD FOR CONSTRUCTION**

RELATED APPLICATIONS

The present invention is related to the following specifications filed concurrently with the application on which this patent is based: "High Performance Stereo Sound Enclosure for Computer Visual Display Monitor and Method for Construction", Serial No. _____; and, "Directional Microphone for Computer Visual Display Monitor and Method for Construction", Serial No. _____.

BACKGROUND OF THE INVENTION

1. Field of the Invention

The present invention relates generally to visual display devices. More particularly, the present invention relates to a computer visual display monitor having an integral stereo sound reproduction facility and an integral microphone.

2. Art Background

Video displays are pervasively used as visual output devices for all types of computer systems. Most commonly, a cathode ray tube (CRT) is enclosed within a supporting enclosure together with associated

subsystems such as CRT control circuits and power supplies to form a computer visual display unit commonly known as a monitor. The monitor is then coupled to receive video signals from a main processor unit including video control logic.

Prior art monitors have not heretofore incorporated high quality audio capability. In fact, prior art computer systems as a whole have only included minimal, low quality sound generation capabilities for limited purposes such as generating user prompt signals, system warning signals, and others. For example, most personal computer systems incorporate a small relatively low performance speaker to produce the above prompt and warning signals, usually comprising one or more low fidelity "beep" tones, or very simple synthesized speech phrases. In low performance audio applications, construction and placement of the speaker system usually is immaterial. In fact, in most personal computer systems the speaker is typically mounted to a bottom-, side-, or rear-facing panel of the computer enclosure, thus leaving the front panel of the enclosure free for user access to mass storage devices contained therein, or other user controls. Remote speaker placement is usually adequate for the above-mentioned prompt and warning signals because such sounds generated by computer systems typically comprise relatively narrow bands of sound without any significant low frequency (bass) components, and are played at low volume levels. When complex sounds such as voice and music are generated or played back through a low quality, arbitrarily positioned speaker, the resulting uneven frequency response

severely restricts the utility of the sound system, which is otherwise adequate for simple warning tones.

More recently, with the advent of digital sound recording and processing techniques, the increased use of sound by computers within computing applications, as well as the need for high quality recording and reproduction of sound within personal computing systems, is desirable. However, despite substantial improvements in personal computing system performance in terms of numeric processing speed and visual display clarity, the recording and reproduction of high quality sound within computer systems have not enjoyed similar advancements. In other words, although modern digital recording techniques produce very high quality source material, the recreation of high quality sound from such recorded media within computing environments generally, and personal computing environments specifically, has been extremely poor in the prior art. The foregoing is principally due to the inability to generate high quality full frequency sound from a small panel-mounted speaker, as previously described in connection with personal computer systems. The audio reproduction problem is compounded even further when reproduction of high quality stereophonic sound is desired.

Although relatively high quality full frequency stereophonic sound has been integrated into television environments, such integration is fundamentally different from the application of high quality sound to computer visual display monitors. First, television images are generated

by relatively low resolution analog signals, which images can be created on large dot pitch CRTs, i.e., where the illuminating phosphor dots are spaced further apart. By contrast, computer generated images, whether animated or sampled video signals, are significantly higher resolution digital images requiring much finer dot pitch CRTs. Typically, television CRTs employ what is known as a shadowmask to help direct the phosphor-exciting electrons to the appropriate phosphors.

Shadowmasks are opaque sheets having as many holes as there are phosphors, which holes are usually grouped in 3's with space provided between the groups. Although completely adequate for most television viewing, shadowmasks are inherently performance limited: the hole spacing limits the ultimate resolution, and the mask itself blocks a significant percentage of total electron flux, thereby limiting the CRT's brightness. A few CRTs employ an alternative screening device known as an aperture grill, such as the Trinitron® CRT manufactured by Sony Corporation. Trinitron® CRTs employing aperture grills can be constructed in normal resolution as well as high resolution variants, and consist essentially of an arrangement of finely spaced wires which can be caused to vibrate at some resonant frequency. Unlike the larger, normal resolution aperture grills which resonate at a very low frequency or not at all, the smaller, high resolution aperture grills used in computer display monitors can have their resonant frequencies well within musical and ordinary listening frequencies. Accordingly, if a high quality stereophonic sound system is brought into sonic communication with a high resolution aperture grill having its natural frequency within the musical spectrum, the

grill will vibrate and severely degrade visual image quality displayed on the CRT, usually manifesting itself as shimmering waves of darkness and brightness similar to Moiré interference. The foregoing image degradation usually is not encountered in lower resolution displays intended for television use for several reasons, including the fact that television images typically comprise non-static, non-uniform backgrounds. In contrast to typical television images, computer system images frequently include stationary, homogeneous shapes and colors, against which the image degradation due to aperture grill vibration is easily and noticeably seen. However, the aperture grill problem will have to be addressed when designing high resolution CRT display devices incorporating high quality sound reproduction systems, whether for computer environments or for the anticipated High Definition Television (HDTV) systems presently under design.

Finally, prior art computer systems are generally not constructed to facilitate recording of voice signals, in particular for purposes of speech recognition. Where facility for voice recording is provided in prior art systems, typically an external microphone must be maintained in close proximity to the speaker's mouth, for example by gooseneck extension or by a headset arrangement. Such microphone attachment effectively ties the user to the computer and restricts the user's movement. Alternatively in the prior art a microphone may be attached to an exterior surface of a computer system component such as the processor enclosure or the monitor. However, such external attachments typically result in non-

optimal microphone performance, where directional characteristics of the microphone, if any are provided by its design, are arbitrarily modified by nearby reflecting surfaces and refracting edges. The result is that the ratio of the desired speech signal to undesired room noise and reflections is unacceptably degraded.

As will be described in the following detailed description, the present invention overcomes many of the limitations associated with prior art computer systems and visual displays by providing an integrated, high resolution, video display monitor incorporating high quality stereophonic sound generation facility as well as speech recognition differential microphone. A user of the present invention can use the integrated monitor of the present invention to display high quality graphics or video data accompanied by full frequency stereophonic sound without compromising the quality of the projected image. Furthermore, the integral directional microphone is positioned and optimized to receive and resolve human speech generated by the computer user, and to provide maximum cancellation of unwanted sounds. The signal from the microphone may then be used for many applications where clear pickup of speech is required, such as voice recognition, teleconferencing, and voice annotation.

SUMMARY OF THE INVENTION

A cathode ray tube (CRT) visual display monitor intended for personal computer systems and integrating a high quality stereophonic speaker system and a directional speech recognition microphone, and methods for construction of same, are disclosed. The CRT is contemplated to be of a high resolution type incorporating a comb-like vertical aperture grill having a natural frequency within the musical scale.

The stereo speaker system comprises a ported speaker enclosure within which are mounted two conventional speaker assemblies. A stereo audio amplifier and control unit for modifying the audio signals delivered to the speakers is mounted within the speaker enclosure. The speaker enclosure is internally mounted within the monitor such that the speakers mounted therein project sound in a direction towards the user facing the monitor. Further, the speaker enclosure is mounted with a minimum number of attachment members, which members include vibration isolation material to attenuate transmission of vibration components near the resonant frequency of the aperture grill when the speaker system is operating. The material, shape, and assembly method of the speaker enclosure are selected to reduce structural deformations contributing to airborne transmission of vibration to the aperture grill.

The integral directional microphone assembly comprises a pressure gradient electret microphone capsule located within a

directional sensitivity-modifying microphone housing. The housing further comprises a microphone preamplifier, and is mounted internally within the monitor housing facing the user and adjacent to the top surface of the monitor housing. The microphone housing has a large frontal opening and a plurality of rearwardly facing openings which together enable differential sound pressures to be applied to the directional microphone capsule retained therein by acoustically transparent foam. The directional characteristics of the microphone assembly, when installed within the monitor housing, are optimized for maximum rejection of noise and undesired sounds.

BRIEF DESCRIPTION OF THE DRAWINGS

The present invention will be understood more fully from the detailed description given below and from the accompanying drawings of the preferred embodiment of the invention in which:

Figure 1A is a perspective illustration of a cathode ray tube (CRT) high resolution video display monitor integrating a stereo speaker arrangement and a directional microphone arrangement according to the present invention being used in a typical personal computing environment.

Figure 1B is an exploded view illustration of the high resolution CRT monitor shown in **Figure 1A**, including a CRT having an aperture grill.

Figure 2A is a front perspective view of the stereo speaker arrangement and a first vibration attenuating grommet.

Figure 2B is a rear perspective view of the stereo speaker arrangement and a second vibration attenuating grommet.

Figure 3A is a perspective view of the first vibration attenuating grommet.

Figure 3B is a perspective view of the second vibration attenuating grommet.

Figure 4 is an exploded view illustration of the stereo speaker enclosure of the present invention.

Figure 5A illustrates the theoretical frequency response of structural and airborne vibrations transmitted from the speaker enclosure to the CRT/aperture grill.

Figure 5B is an empirical plot of the audio frequency response of the speaker enclosure.

Figure 6A is an exploded view perspective illustration of the directional microphone arrangement of the present invention.

Figures 6B-C are alternative top plan and front elevation views of the voice recognition microphone shown in **Figure 6A**.

Figure 7 is a polar plot of directional microphone spatial response relative to on-axis response at 400 Hz and 1 kHz.

Figure 8 is a cross-sectional side view of the interior of the directional microphone illustrating the electrostatic shielding arrangement.

DETAILED DESCRIPTION OF THE INVENTION

The present invention discloses an integration arrangement for a cathode ray tube (CRT) high resolution visual display monitor intended for personal computer systems and integrating a high quality stereophonic speaker system and a directional microphone, and methods for construction of same.

In the following description, for purposes of explanation, specific numbers, times, dimensions, and configurations are set forth in order to provide a thorough understanding of the present invention. However, it will be apparent to one skilled in the art that the present invention may be practiced without these specific details. In other instances, well known systems are shown in diagrammatic or block diagram form in order not to obscure the present invention unnecessarily.

THE INTEGRATED MONITOR

Reference is now made to **Figure 1**, wherein is shown an exploded view illustration of an integrated, cathode ray tube (CRT) high resolution video display monitor **5** integrating a stereo speaker arrangement and a voice recognition microphone arrangement intended for personal computing environments. As shown in **Figure 1**, monitor **5** comprises a housing **7** enclosing a high resolution CRT **8** of the type employing a vertical aperture grill **9** to direct an impinging electron beam (not shown) sourced from an electron gun **12** towards a multiplicity of

screen phosphors 13 formed on an interior surface of a CRT screen 14. Unlike the more commonly employed perforation shadow mask (not shown) comprising an opaque shield having a large number of regularly spaced clusters of circular perforations aligned with the CRT phosphors 13, the aperture grill 9 comprises a comb-like structure having a large number of narrowly spaced wires 16 which vertically span the interior surface of screen 14. Wires 16 are aligned to CRT 8 such that electrons in the electron beam which pass between any two wires strike and illuminate the corresponding phosphors 13, the space between any two wires corresponding generally to the width of a phosphor. Alternatively, electrons which strike any wire 16 will not strike, and thus will not illuminate, a phosphor 13. In CRT 8, the wires 16 of aperture grill 9 are more closely spaced than the perforations in a shadow mask, and extend in a direction orthogonal to the horizontal scan direction of the electron beam. A widely known example of a CRT employing an aperture grill is the Trinitron[®] CRT manufactured by Sony Corporation. Trinitron[®] CRTs employing aperture grills can be constructed in normal resolution as well as high resolution variants.

As described, wires 16 of aperture grill 9 form a tuned mechanical system which has a resonant, or natural, frequency. The natural frequency depends upon the length, the diameter, and the spacing of the wires 16 comprising grill 9, as well as the size of the CRT screen 14. As practiced in the present invention, the aperture grill 9 of the high resolution Trinitron[®] CRT has its natural frequency within the audible

spectrum near 440 hertz (Hz), equivalent to the musical tone middle "A". Other tunings are possible depending on materials and dimensions of the aperture grill being designed. Throughout this section, and for the balance of this detailed description, the present invention benefits from engineering features which minimize or preclude transmission of structural or airborne vibration from sound generation devices to CRT 8, and specifically to the aperture grill 9 within the CRT 8.

As shown in **Figure 1**, housing 7 comprises a bottom panel 7a, a front panel 7b, side panels 7c and 7d, a back panel 7e, and a top panel 7f. Housing 7 is mounted upon and supported by a base 6 which includes a tilting and swiveling means 4 for adjusting housing 7 to any desired position for viewing depending on the user's preference. A ported stereo speaker enclosure 20, comprising a pair of conventional voice coil actuated cone speakers 21a and 21b mounted at laterally opposing ends of enclosure 20, is mounted inside housing 7 below CRT 8. As shown in **Figure 1**, speaker enclosure 20 is located inside housing 7 directly behind front panel 7b and positioned above bottom panel 7a and between side panels 7c and 7d. Speaker enclosure 20 is mounted to housing 7 with an absolute minimum number of attachment points to minimize structurally transmitted vibration from the speaker enclosure 20 to aperture grill 9 within CRT 8. Details concerning the internal arrangement and construction of speaker enclosure 20 will be described more thoroughly below in the section entitled "Speaker Enclosure".

With reference to **Figures 1A and 1B**, attachment points are provided on enclosure **20** by identical first and second cylindrical bosses **22** and **23** extending outward from opposing distal ends of the enclosure **20**, as well as an ovaloid tubular member **25** extending outward from an ovaloid opening **24** in the rear portion of enclosure **20**. In an alternative embodiment, bosses **22** and **23** may be replaced with a pair of pin members or self-tapping screws (not shown) projecting through a locating opening (not shown) formed in a tab (not shown) extending from enclosure **20**. As shown in **Figure 1A**, bosses **22** and **23** are solid members with no porting functionality. In **Figure 1B**, tubular member **25** is shown to have a flanged portion **25a** at the end of a tube shaft **25b**, and in addition has an open volume **25c** disposed within the interior of shaft **25b**. Flanged portion **25a** of member **25** is commensurately larger than the cylindrical bodies of bosses **22-23**, due to the presence of the open volume **25c** defined within shaft **25b**. The function of tubular member **25** is two-fold. Firstly, member **25** serves as an attachment point for the posterior portion of the speaker enclosure **20** to the monitor enclosure **7**. Secondly, opening **24** fitted with tubular member **25**, specifically volume **25c** within shaft **25b**, comprises a port through which air may pass as necessary in connection with motion by the speaker cones of speakers **21a** and **21b**, as is generally known in the design and construction of speaker systems. Acoustic aspects and other associated functionality of the port provided by opening **24** and tubular member **25**

will be discussed in more detail below in connection with the speaker enclosure itself.

Over each of the cylindrical diameters of each of the bosses **22** and **23**, and over the ovaloid diameter of tubular member **25**, is fitted an elastomeric grommet **27a**, **27b**, and **27c**, respectively, formed of an energy dissipative material specified to absorb vibration components near the natural frequency of aperture grill **9**, and principal harmonics thereof. The elastomeric grommets **27a-c** are formed of any suitable commercially available vibration damping material such as IsoLoss or C-1002. In one embodiment, grommets **27a-c** are fabricated of chlorobutyl rubber, manufactured by Exxon Corporation.

Reference is now made to **Figures 2 and 3**. In **Figure 2**, grommets **27a** and **27b** are identical and are shown in perspective view, each grommet **27a** and **27b** having an annular groove **28** extending around an external circumference **29a** centered between two planar faces **30a** and **30b**. Further, grommets **27a** and **27b** have an internal circumference **29b** dimensioned to conform snugly over either boss **22** or **23**, internal circumference **29b** further comprising a first multiplicity of rib members **31**. As shown, rib members **31** minimize contact area between grommets **27a-b** and bosses **22-23** and stiffen the grommet material contacting the boss **22** or **23**. Every other one of rib members **31** extends beyond the planar faces **30a** and **30b** of the grommet, thereby forming vibration absorbent cushions **31a** which provide

vibration attenuation in an axial dimension. Rib members **31** minimize total contact area between grommets **27a-b** and bosses **22-23**, and stiffen the grommet material contacting the boss **22** or **23** when enclosure **20** is mounted to the housing **7**. The combined effect of contact area reduction and material stiffening reduces the conduction path for mechanically transmitted structural vibrations produced by speakers **21a** and **21b** within the speaker enclosure **20** from reaching the aperture grill **9**. In **Figure 3**, grommet **27c** is shown in perspective view to comprise an ovaloid body **32** having an internal circumference **32a** conformally extending over the shaft portion **25b** of tubular member **25**. Moreover, grommet **27c** is shown to have an external circumference **32b**, there being an annular flange-like structure **32** bounding one side of a cylindrical body **32**. A second multiplicity of rib members **33** is distributed at regular intervals on external circumference **32b**. As in the case of grommets **27a** and **27b** shown in **Figure 1a**, the rib members **33** formed on external circumference **32b** of elastomeric grommet **27c** generally serve to minimize total contact area between the support point at the rear of speaker enclosure **20**, namely opening **24**, and housing **7**, thus ensuring that structural vibrations sourced from the speaker enclosure **20** are effectively interdicted prior to adversely affecting the aperture grill **9** within the high resolution CRT **8**. Importantly, the size and number of first and second pluralities of rib members **31** and **33** are adjusted so that the natural frequencies of the several grommets (**27a-27c**) are the same.

Referring now to **Figures 1-3** inclusively, mounting of speaker enclosure **20** into housing **7** will be described. When speaker enclosure **20** is moved into position above bottom panel **7a** and between side panels **7c** and **7d**, the bosses **22** and **23** fitted with elastomeric grommets **27a** and **27b**, are respectively received into a pair of complementary slotted sockets **33a** and **33b** respectively formed in the side panels **7c** and **7d** of housing **7**. At the same time, the flanged portion **25a** of tubular member **25** is received into a socket **33c** formed in rear panel **7e** of housing **7**. The elastomeric grommet **27c** fitted to the shaft **25b** of tubular member **25** is thereby seated within opening **24** in enclosure **20**. Slotted sockets **33a** and **33b** bear against the annular grooves **28** of each of the respective elastomeric grommets **27a** and **27b**, and partially compress the compliant material so as to secure the grommets, and thus the bosses **22** and **23**, within the slotted socket region. The speaker enclosure **20** is thus retained within housing **7** with only three support points: one at each of the distal ends of the speaker enclosure **20** (bosses **22** and **23**), and one at the rear of the enclosure **20** (opening **24**).

With respect to grommets **27a**, **27b**, and **27c**, the desired degree of vibration isolation between enclosure **20** and housing **7** is achieved by compressively loading the grommets within their respective attachment points, namely socket regions **33a** and **33b** for grommets **27a** and **27b**, and opening **24** for grommet **27c**. At room temperature, the elastomer material forming grommets **27a-b** experiences a 10dB/octave rolloff from

a cutoff frequency of approximately 140 Hz. In the present embodiment of the invention, with an approximate speaker enclosure load (weight) of about 4 pounds force (lbf), vibration transmission through grommets **27a**, **27b**, and **27c** loaded to approximately 1.3 lbf each will attenuate vibrations at the expected 10dB per octave from a natural frequency of approximately 100 Hz. It should be noted that structural vibration generated within speaker enclosure **20** is substantially reduced at higher frequencies before being channeled through the attachment points, namely grommets **27a-c** into housing **7**. Accordingly, the aperture grill **9** having its natural frequency near 440 Hz is substantially isolated from the vibration source of enclosure **20**.

Still referring to **Figure 1**, the integrated monitor housing **7** of the present invention further comprises an internal, directional microphone unit **50** intended principally to pick up speech for applications requiring optimal fidelity in reproduction. As shown in **Figure 1**, microphone unit **50** is mounted in housing **7** so as to be directly accessible to speech emanating from a user seated before monitor **5**, and also to be centrally located near the juncture of front panel **7b** and top panel **7f**. Microphone unit **50** is mounted within housing **7** by any appropriate system of snaps and hooks, screws, rivets, or other generally known method. Vibration and noise isolation of the microphone unit **50** is achieved by use of insulative materials and shielding, as is also described below.

The upper-central location of the microphone unit **50** is selected for several reasons. First, the elevated location places the microphone unit **50** as nearly as possible in the direct path of speech sound waves sourced from a user who is speaking. Second, the location adjacent to top panel **7f** enables microphone unit **50** to be enclosed in a housing having apertures optimized to admit sound waves from all directions, so that the pressure gradient vector relationships between these sound waves are preserved and the rejection of sounds arriving from the sides and rear can be improved. Thirdly, the elevated location allows the microphone unit **50** to be positioned such that off-axis nulls in its directional response pattern are oriented to face common sources of undesired noise such as keyboards, disk drives and cooling fans in computer enclosures. As shown in **Figure 7** below, by directing the off-axis nulls towards sources of unwanted sound, the undesired noise components are reduced in microphone total output. Each of the above considerations is discussed in more detail below in the section entitled "Integrated Microphone".

THE SPEAKER ENCLOSURE

Reference is now made to **Figure 4** wherein is illustrated an exploded perspective view of the ported speaker enclosure **20** of the present invention. In **Figure 4**, speaker enclosure **20** comprises upper and lower halves **40a** and **40b** formed substantially as shown of a rigid

and dense material. Upper half **40a** includes two extended angulated surfaces **42a** and **42b** each having a circular cutout **43a** and **43b** dimensioned to receive speakers **21a** and **21b**. Speakers **21a** and **21b** are positioned upon surfaces **42a** and **42b** such that the associated voice coils and cone spiders (not shown) extend through cutouts **43a** and **43b**. As a result, speakers **21a** and **21b** are substantially flushly mounted against surfaces **42a** and **42b**, thereby permitting speaker enclosure **20** to be positioned immediately behind the lower portion of front panel **7b** when mounted within housing **7**.

As shown in **Figure 4**, the interior surfaces of upper and lower halves **40a** and **40b** each comprise a multiplicity of integral, orthogonally extending ribs **41a** and **41b** to enhance the structural strength of the respective halves. In particular, it is desirable that sonic energy derived from speakers **21a** and **21b** causing air movement within the ported enclosure **20** does not create structural deformations sufficient to generate airborne transmitted vibrations within housing **7** which can stimulate aperture grill **9** to vibrate at its resonant frequency. Empirical testing of the present embodiment indicates that as much as two thirds of the total vibration induced in the integrated monitor is due to airborne transmission, with only one third due to structural transmission. Ribs **41a-b** enhance the flexural rigidity of the halves **40a-b**. Flexural deformation is further avoided by using as stiff material as possible for halves **40a** and **40b**. Structural plastics such as ordinary ABS or polycarbonate, while generally adequate, were found to be too

deformable for the present application. Accordingly, the material selected to fabricate enclosure halves **40a-b** comprises a glass-filled PVC having approximately three times the flexure modulus and 1.3 times the density of ordinary PVC, for example FiberLock 812GR30, supplied by Geon Company, 6100 Oak Tree Blvd., Cleveland, OH 44131. By using a very dense and stiff material for upper and lower halves **40a** and **40b**, enclosure **20** can be made stiff yet have a lower natural frequency than would otherwise be obtainable using ordinary structural plastics.

Moreover, as shown in **Figure 4**, upper and lower halves **40a** and **40b** comprise a multiplicity of surface contours and seams where contours meet. The surface topology of enclosure **20** as defined by the upper and lower halves is dictated in part by the need to conform to the available internal volume of monitor housing **7** wherein which enclosure **20** is mounted, and in part by the need to increase the overall stiffness of the enclosure **20**. As presently practiced, halves **40a** and **40b** have a thickness of approximately 4 millimeters (mm), yielding a very stiff, yet moldable, enclosure.

Tubular member **25**, in addition to comprising a point of attachment for the enclosure **20** as previously described, also operates in concert with opening **24** to achieve a porting function in connection with the audio characteristics of speaker enclosure **20**. Specifically, enclosure **20** is a ported enclosure of the type well known in art of speaker construction to enhance low frequency response. In order to

achieve full spectrum response in the present invention, that is, to permit long wavelength low frequencies to exit enclosure **20** and contribute to the total audio spectrum emanating from the speaker enclosure, the port must be dimensionally tailored to the specific performance criteria desired to be realized for the particular speaker enclosure being designed. In the present invention, tubular member **25**, and particularly shaft **25b** and flanged portion **25a**, when fitted within opening **24** comprise a tuned port in accordance with generally recognized design principles of bass-reflex speakers.

The ported speaker enclosure **20** functionally facilitates longer wavelength, lower frequency sound waves to be emitted from the rear of enclosure **20**, and thus from housing **7**, in a specific phase relationship with the sound waves emitted from the front of enclosure **20** through openings (not shown) in bottom panel **7a**. Specifically, sound waves emanating from bottom panel **7a** are reinforced by addition rather than reduced by cancellation. Two benefits are readily gained thereby. First, mechanical vibration associated with the lower frequency sounds is not coupled into enclosure **20** or housing **7**, thereby isolating aperture grill **9** from the longer wavelength higher energy waves. Second, by projecting the low frequency sounds from tubular member **25** at the rear panel **7e** of monitor housing **7**, the lower bass frequencies are not absorbed or distorted within either the speaker enclosure **20** or monitor housing **7**, but rather are emitted in the correct phase to be added to the total sound generated by speaker enclosure **20**. Superior acoustic performance is

achieved thereby, in particular extended low frequency response compared with a similar speaker enclosure having no tuned port.

Continuing now to refer to **Figure 4**, between upper and lower halves **40a** and **40b** is located a printed circuit board (PCB) **44** comprising an audio control and amplifier unit **45** for controlling the operation of speakers **21a** and **21b**. In particular, audio control and amplifier unit **45** enables the user to provide audio signal processing algorithms including psychoacoustic sound shaping techniques known in the art to broaden the sound stage to and to alter the apparent source of the audio signals for the user, for example "elevating" the perceived source of sound or compensating for nonlinear acoustic sensitivities in a listener.

Upper half **40a** also comprises a centrally located, rectangular polygon cutout **46** corresponding to a region of PCB **44** where a speaker system wiring bundle (not shown) is coupled to one or more connectors (not shown) on the PCB. The balance of audio processing components (not shown) comprising audio control and amplifier unit **45** are positioned on PCB **44** such that they are enclosed within speaker enclosure **20**. Locating of the audio processing components, and particularly the output level amplifiers, within the enclosed volume of enclosure **20** takes advantage of scavenging airflow through the port (tubular member **25**) associated with air movement caused by speakers **21a** and **21b** as the cone elements of each speaker translate forward and backward. That is,

the air movement into and out of enclosure 20 through the port (member 25) when speakers 21a and 21b are operating provides forced-air cooling for heat-producing devices located within the enclosed volume. Accordingly, more audio output power can be developed without need for typical forced or passive cooling devices such as fans and or ventilation openings.

In the present invention, maximum forced-air cooling is obtained within the speaker enclosure 20 at the most opportune time, namely at maximum power output of audio control and amplifier unit 45 positioned on PCB 44 . Because the speaker cone must move more air to create louder sounds, the speaker cone must be driven a commensurately longer distance by its associated electromagnetic voice coil. The greater the distance the voice coil must move, the greater the current and power draw from the amplifier unit 45 will be. The greater air movement, in turn, creates the airflow within enclosure 20, which airflow will draw away heat from any heat-producing devices within the enclosure.

Referring now briefly to **Figures 5A and 5B**, empirical frequency response data for speaker enclosure 20 are shown. In **Figure 5A**, transmissibility of vibration through the elastomer grommets 27a, 27b, and 27c is shown for increasing frequency. After an initial rise at the natural frequency of the grommet, the transmissibility is seen to decline at the expected 10 dB/octave. In **Figure 5B**, total acoustic frequency response is shown for increasing frequency.

THE INTEGRATED MICROPHONE

Referring now to **Figure 6A**, an exploded perspective view of the integral, directional microphone unit **50** of the present invention is illustrated. As previously set out, integral microphone unit **50** is designed principally to record spoken words for applications requiring optimal fidelity in reproduction, and to reject signals emanating from sources not in front of the monitor **5**. The present invention is implemented so that microphone unit **50** will function as a directional, pressure gradient microphone, producing a hypercardioid spatial response characteristic and having a linear frequency response in the range of human speech. As practiced, microphone unit **50** generates a hypercardioid response characteristic having a flat on-axis response in front, with sharp rejection laterally leading to two off-axis nulls towards the rear. The response can be modeled as:

$$r = 0.3 + 0.7\cos q$$

where 0.3 comprises a pressure term, 0.7 comprises a pressure gradient term, and q is the angular displacement in an azimuth plane away from a colinear microphone axis extending through the microphone housing, shown graphically in **Figure 7**. The desirability of the above response characteristic was ascertained from empirical evidence derived from voice recognition algorithm development, as well as the design goal of reducing as much as possible the microphone's random energy efficiency. The hypercardioid pattern results in the highest directivity, i. e.

the lowest random energy efficiency, of any first-order pressure gradient microphone. Most notably, the above response characteristic was achieved by placing cardioid capsule **53** inside microphone unit **50**, and locating unit **50** at an external surface discontinuity of housing **7**.

The principal feature of the integral microphone of the present invention is that the placement of the microphone unit **50** containing the cardioid capsule **53** at an exterior vertex **7g** formed at the juncture of front panel **7b** and top panel **7f** enhances the directionality of capsule **53**, thereby substantially reducing sensitivity to off-axis undesired sounds. Generally, placing a microphone on a solid surface will cause pressure doubling at the microphone for wavelengths which are short compared to the dimensions of the object on whose solid surface the microphone is placed. Modification of the sound entry paths (e.g., opening **63**, **Figure 6A**, or openings **70**, **Figure 6B**, described below) to pressure gradient microphones such as capsule **53** of the present invention, will cause deviations in the inherent directionality and frequency response of the microphone. Both the placement and entry path techniques are used in the present case. Microphone capsule **53** is constructed to have a cardioid directional pattern, having a single null at 180° in azimuth from 0° (on-axis) centerline. Placing microphone unit **50** at the vertex **7g** of monitor **5**, and the modification of the sound pressure and pressure gradient response of the microphone by the use of selectively perforated housing **50** result in a directional pattern which is not cardioid, but rather is hypercardioid.

As shown in **Figure 6A**, microphone unit **50** comprises upper and lower halves **60a** and **60b** enclosing conventional pressure gradient electret microphone capsule **53**. Upper and lower halves **60a** and **60b** each comprise a linear front edge **61** and a circular rear edge **62**. A generally rectangular opening **63** is formed in front edge **61** of lower half **60b**, opening **63** defining a front portion of unit **50**. Upper half **60a** comprises a top surface **64** further comprising a subsided region **64a** formed therein, region **64a** commencing from a lower edge **65a** of an angulated surface **65** which adjoins linear edge **61**. Subsided region **64a** extends rearwards in a direction away from opening **63** towards the circular rear edge **62** of upper half **60a**. As subsided region **64a** extends rearward, it rises smoothly to meet top surface **64** at the rear edge **62** of upper half **60a**. Capsule **53** is retained within the subtended volume between upper and lower halves **60a** and **60b** by acoustically transparent foam **66**. A coaxial signal and ground lead **67** extends from capsule **53** through foam **66** and exits from unit **50** at a point between circular edges **62** of upper and lower halves **60a** and **60b**.

With reference to **Figures 6A** and **6B**, a rearwardly facing convex swell **68** is formed in the central region of angulated surface **65** and smoothly merging into the subsided region **64a** of top surface **64**. Formed in convex swell **68** is a evenly distributed multiplicity of circular openings **70**. Circular openings **70** are formed in such a manner as to be acoustically accessible from the rear of microphone unit **50**, that is, in

a direction extending from circular rear edges 62 toward convex swell 68. More particularly, openings 70 are intended to receive undesired sound waves from sources other than in front of housing 7. The smooth topologies of subsided region 64a and convex swell 68 are intended to minimize or avoid sharp boundary transitions which will cause reflected sound waves to diffract and potentially interfere. As is well known in the art, pressure gradient microphones such as cardioid capsule 53 are dependent for their inherent directional characteristics on the pressure gradient between openings in at least two of their external surfaces, for example front and side. In the present invention, subsided region 64a, being generally lower than the openings 70 formed in convex swell 68, inherently enables sound waves from the surrounding acoustic environment to be directed back into microphone capsule 53. Specifically, in the present configuration extraneous sound waves are channeled to a rearward facing opening 54 in a rear surface of capsule 53. The entire structure of microphone unit 50 is designed to allow controlled access of the pressure component of sound waves to capsule 53, and to preserve as nearly as possible the pressure gradient (i.e., velocity) of the sound waves so as to be sensed by capsule 53.

In an ordinary office environment, undesired sounds impinge on microphones from all directions. It is therefore the goal of the present invention to reduce the overall pickup of undesired sounds in the whole space surrounding the monitor 5 as much as possible, while maintaining fidelity of transmission for sounds arriving from the user (e. g., speech).

The known figure of merit for the overall pickup selectivity of microphones is their directivity index or random energy efficiency,

$$REE = \frac{1}{4\pi} \int_0^{4\pi} f^2(\theta) d\Omega_\theta$$

where $f(\theta)$ is the ratio of voltage output for incidence at angle θ to that for $\theta=0$, and $d\Omega_\theta$ is the element of solid angle at angle θ .

Lower REE values indicate lower pickup of surrounding sounds. An omnidirectional microphone has an REE of 1, while a conventional cardioid microphone such as capsule 53 has an REE around 0.33. The lowest REE that is achievable with a first order pressure gradient differential microphone is around 0.25 for the hypercardioid pattern. It was accordingly an object of this invention to implement the hypercardioid pattern in the microphone, which has a polar response in an azimuth plane which can be described by the equation

$$r = 0.3 + 0.7 \cos \theta.$$

Although the non-zero response of the hypercardioid pattern at $\theta = 180^\circ$ (i. e. directly behind the monitor) may initially appear problematic, in ordinary office environments sounds arriving from behind the monitor 5 are typically attenuated because no nearby noise sources typically exist there.

In the present invention, microphone unit **50** makes use of the mechanical design of its housing structure as described above, acoustic foam **66** and an acoustic grill **73** to modify the directional response of microphone capsule **53** from its inherent cardioid polar response to the desired hypercardioid polar response. The acoustic foam **66** also comprises a shock mount for the microphone capsule **53**, as well as providing isolation from structural borne vibration. Total acoustic resistance can be adjusted by adjusting the density of the foam, the number of holes, the size of holes, etc., as measured by any of several standard units: IFD (indent force deflection), PPI (perforations per inch), as is generally known.

In any application involving CRTs, noise immunity of certain devices must be considered, especially where low level signals are transmitted in an otherwise high level environment. For example, both magnetic and electrostatic noise from CRT could potentially be coupled into the microphone unit **50**. However, in the present invention, because the microphone capsule **53** within microphone unit **50** is placed at the front exterior vertex **7g** of housing **7**, the only significant noise contribution is due to electrostatic noise. In this regard, placement well away from the yoke assembly (**12, Figure 1A**) precludes need for more elaborate and costly (e.g., mu-metal) shielding techniques. With brief reference to **Figures 6A and 10**, adequate electrostatic shielding is accomplished in the present invention with only a sheet of copper foil **72** fitted to the bottom half **60b**, which copper foil **72** is made to contact the

ground braid of the coaxial signal lead at a crimp point when upper and lower halves **60a** and **60b** are joined. The braid is grounded. Microphone output signals travel in the center conductor of the coaxial lead **67**, which also provides power to the microphone capsule **53** which contains a field effect transistor impedance converter stage, as is known in the art.

Finally, as a design requirement, microphone enclosure **50** must be manufacturable from cost and tooling considerations, and yet be sufficiently robust to withstand expected wear and tear while monitor **5** is in use. Although a thin, fine mesh metallic screen would be superior acoustically, such a material employed as top surface **63** would be extremely fragile in an ordinary work environment. Accordingly, as embodied in the present invention, both upper and lower halves **60a** and **60b** are formed of 1.5 mm thick PVC plastic which readily is moldable in to the required shaped for top surface **63**. In the present embodiment, openings **70** have 2 mm diameters and 3 mm spacing empirically derived to be as optimally transparent as possible for the frequency range encountered in human speech. Given that the thickness of top surface **63**, including convex swell **68** will cause some interference of the sound waves entering microphone unit **50** through openings **70**, the output signal from microphone enclosure **50** will be reduced. Where thinner materials are appropriately used, top surface **63** can be made more acoustically transparent, thus yielding a better output signal.

SUMMARY

The foregoing has described a CRT visual display monitor of the type incorporating a high resolution aperture grill intended for personal computer systems, and integrating a high quality stereophonic speaker system and a directional microphone optimized for pick up of human speech, and methods for construction of the monitor. Although the foregoing has been described in terms of presently preferred and alternate embodiments, those skilled in the art will recognize that the invention is not limited to the embodiments described. The method and apparatus of the present invention can be practiced with modification and alteration within the spirit and scope of the appended claims. The description is thus to be regarded as illustrative instead of limiting on the present invention.

CLAIMS

We claim:

1. In a digital computer information processing system including a central processor unit producing a plurality of computer-processed video and audio signals, an integrated computer visual display monitor comprising:

a high resolution cathode ray tube (CRT) display including an aperture grill coupled to receive and display said video signals, and

stereo sound transducer means for reproducing said audio signals suspended within said monitor and coupled to receive said audio signals.

2. The integrated computer visual display monitor according to claim 1, wherein said stereo sound transducer means comprises:

a speaker enclosure having a pair of voice coil actuated cone speakers affixed thereto, and

a tuned port for exhausting a plurality of low frequency sound waves from said speaker enclosure;

and,

elastomeric suspension means for supporting said stereo sound transducer means within said monitor and attenuating mechanical vibrations created by speaker enclosures.

3. The integrated computer visual display monitor according to claim 2, wherein:

said aperture grill comprises a tuned system having a first natural frequency centered substantially within a musical bandwidth,

and

said tuned port comprises a tuned resonator having a second natural frequency less than said first natural frequency.

4. The integrated computer visual display monitor according to claim 2, wherein said speaker enclosure comprises a rigid, hollow body further comprising enclosure strengthening means for resisting deformation of said speaker enclosure when said speakers are active.

5. The integrated computer visual display monitor according to claim 4, wherein said enclosure strengthening means comprises a first plurality of intersecting rib members integrally formed on interior surfaces of upper and lower portions of said speaker enclosure.

6. The integrated computer visual display monitor according to claim 5, wherein said speaker enclosure consists essentially of glass-filled PVC.

7. The integrated computer visual display monitor according to claim 2, wherein said elastomeric suspension means

comprises a plurality of energy-dissipating grommets seated on corresponding mounting surfaces formed in said speaker enclosure, said grommets compressively interspersed between said rigid housing and said monitor when said speaker enclosure is mounted within said monitor.

8. The integrated computer visual display monitor according to claim 7, wherein said energy-dissipating grommets comprise first and second cylindrical side grommets and an ovaloid rear grommet, said side grommets each comprising an interior circumference having a second plurality of rib members disposed thereon and having a third natural frequency substantially equivalent to said second natural frequency, said rear grommet comprising an exterior circumference having a third plurality of rib members disposed thereon and having a fourth natural frequency substantially equivalent to said second and third natural frequencies.

9. The integrated computer visual display monitor according to claim 2 further comprising a sound processor board mounted internally within said speaker enclosure and coupled to receive said computer-processed audio signals, said sound processor board further comprising amplifier and sound control means for shaping and modifying a plurality of acoustic characteristics of said computer-processed audio signals.

10 The integrated computer visual display monitor according to claim 9, wherein said sound processor board mounted internally within said speaker enclosure is cooled by air passing through said port and into said speaker enclosure when said speakers are active.

11. The integrated computer visual display monitor according to claim 1 further comprising directional microphone transducer means suspended within said monitor for receiving a plurality of speech sounds spoken by a user in connection with a plurality of computer-controlled functions operation and control of said computer digital information processing system.

12. The integrated computer visual display monitor according to claim 11, wherein said directional microphone transducer means comprises a pressure gradient electret microphone capsule having first and second sound pressure ports housed within a microphone enclosure having a frontal acoustical transparency and a rear acoustical transparency, said microphone enclosure located at an upper exterior vertex of said monitor facing the user such that said first sound pressure port is principally accessible to said speech sounds received through said frontal transparency, and said second sound pressure port is principally accessible to a plurality of sounds received through said rear acoustical transparency, there being a sound pressure gradient between said frontal and said rear acoustical transparencies.

13. The integrated computer visual display monitor according to claim 12, wherein said frontal and rear acoustical transparencies maximally preserve the sound pressure gradient existing between said first and second sound ports of said microphone capsule.

14. The integrated computer visual display monitor according to claim 13, wherein said plurality of computer-controlled functions includes telecommunication transactions.

15. The integrated computer visual display monitor according to claim 13, wherein said plurality of computer-controlled functions includes voice recognition transactions.

16. In a digital computer information processing system including a central processor unit producing a plurality of computer processed video and audio signals, an integrated computer visual display monitor comprising:

a high resolution cathode ray tube (CRT) display including an aperture grill coupled to receive and display said computer processed video signals,

stereo sound transducer means for reproducing said digital audio signals, said stereo sound transducer means suspended within said monitor and coupled to receive said computer processed audio signals, said stereo sound transducer means comprising a speaker enclosure having a pair of voice coil actuated cone

speakers affixed thereto and a tuned port for exhausting a plurality of low frequency sound waves from said speaker enclosure;

elastomeric suspension means for supporting said stereo sound transducer means within said monitor and attenuating mechanical vibrations in said CRT created by said speakers, and

directional microphone transducer means suspended within said monitor for receiving a plurality of speech sounds spoken by a user in connection with operation and control of said computer digital information processing system.

17. The integrated computer visual display monitor according to claim 16, wherein:

said aperture grill comprises a tuned system having a first natural frequency centered substantially within a musical bandwidth, and

said tuned port comprises a tuned resonator having a second natural frequency less than said first natural frequency.

18. The integrated computer visual display monitor according to claim 16, wherein said speaker enclosure comprises a rigid, hollow body further comprising enclosure strengthening means including a first plurality of intersecting rib members integrally formed on interior surfaces of upper and lower portions of said speaker enclosure for

resisting deformation of said speaker enclosure when said speakers are active.

19. The integrated computer visual display monitor according to claim 18, wherein said speaker enclosure consists essentially of glass-filled PVC.

20. The integrated computer visual display monitor according to claim 16, wherein said elastomeric suspension means comprises a plurality of energy-dissipating side and rear grommets seated on corresponding side and rear mounting surfaces formed in said speaker enclosure;

said side grommets each comprising a cylindrical body having an interior circumference including a second plurality of rib members disposed thereon and having a third natural frequency less than said first natural frequency and substantially equivalent to said second natural frequency;

said rear grommet comprising an ovaloid body having an exterior circumference including a third plurality of rib members disposed thereon and having a fourth natural frequency less than said first natural frequency and substantially identical to said second and third natural frequencies;

said grommets compressively interspersed between said rigid housing and said monitor when said speaker enclosure is mounted within said monitor.

21. The integrated computer visual display monitor according to claim 16 further comprising a sound processor board mounted internally within said speaker enclosure and coupled to receive said computer processed audio signals, said sound processor board further comprising amplifier and sound control means for shaping and modifying a plurality of acoustic characteristics of said computer processed audio signals.

22 The integrated computer visual display monitor according to claim 21, wherein said sound processor board mounted internally within said speaker enclosure is cooled by air passing through said port and into said speaker enclosure when said speakers are active.

23. The integrated computer visual display monitor according to claim 16, wherein said directional microphone transducer means comprises a pressure gradient electret microphone capsule having first and second sound pressure ports housed within a microphone enclosure having a frontal acoustical transparency and a rear acoustical transparency, and wherein:

said microphone enclosure is located at an upper exterior vertex of said monitor facing the user;

said first sound pressure port is principally accessible to said speech sounds through said frontal acoustical transparency;

said second sound pressure port is principally accessible to a plurality of sounds waves principally originating from behind and from each side of said microphone enclosure through said rear acoustical transparency, there being a sound pressure gradient between said frontal and said rear acoustical transparencies,

and

said frontal and rear acoustical transparencies maximally preserve the sound pressure gradient applied to said first and second sound ports of said microphone capsule.

24. In a digital computer information processing system including a central processor unit producing a plurality of computer processed video and audio signals, a method for assembling an integrated computer visual display monitor comprising the steps of:

- providing a high resolution cathode ray tube (CRT) display including an aperture grill coupled to receive and display said computer processed video signals;
- providing stereo sound transducer means for reproducing said computer processed audio signals;
- forming, within said sound transducer means, a tuned port for exhausting a plurality of low frequency sound waves from said sound transducer means;
- coupling said stereo sound transducer means to receive said computer processed audio signals,

and,

supporting said stereo sound transducer means within said monitor with elastomeric suspension means for attenuating mechanical vibrations created thereby.

25. The method according to claim 24, wherein providing said stereo sound transducer means speaker enclosure comprises providing a ported speaker enclosure having a pair of voice coil actuated cone speakers affixed thereto.

26. The method according to claim 25, wherein providing said speaker enclosure comprises providing a rigid, hollow body including enclosure, and further providing strengthening means for resisting deformation of said speaker enclosure when said speakers are active.

27. The method according to claim 26, wherein said enclosure strengthening means comprises a first plurality of intersecting rib members integrally formed on interior surfaces of upper and lower portions of said speaker enclosure.

28. The method according to claim 23, wherein:
said aperture grill comprises a tuned system having a first natural frequency centered substantially within a musical bandwidth,
and

said tuned port comprises a tuned resonator having a second natural frequency less than said first natural frequency.

29. The method according to claim 23, wherein the step of supporting said stereo sound transducer means with said elastomeric suspension means comprises the steps of:

providing and seating a plurality of energy-dissipating grommets on a plurality of mounting surfaces formed in said speaker enclosure,

and

compressively interspersing said grommets between said rigid housing and said monitor when said speaker enclosure is mounted within said monitor.

30. The method according to claim 29, wherein said providing said energy-dissipating grommets comprises the steps of:

providing first and second cylindrical side grommets and an ovaloid rear grommet;

forming, in each of said side grommets, an interior circumference having a second plurality of rib members disposed thereon and having a third natural frequency substantially equivalent to said second natural frequency;

and

forming, in said rear grommet, an exterior circumference having a third plurality of rib members disposed thereon and having a

fourth natural frequency less than said first natural frequency and substantially identical to said second and third natural frequencies.

31. The method according to claim 23, wherein providing stereo sound transducer means further comprises mounting a sound processor board internally within said speaker enclosure; coupling said sound processor to receive said computer processed audio signals, and shaping and modifying a plurality of acoustic characteristics of said computer processed audio signals supplied to said stereo sound transducer means by providing amplifier and sound control means on said sound processor board.

32 The method according to claim 31, wherein said sound processor board mounted internally within said speaker enclosure is cooled by air passing through said port and into said speaker enclosure when said speakers are active.

33. The method according to claim 23 further comprising the step of providing and suspending directional microphone transducer means within said display monitor for receiving a plurality of speech

sounds spoken by a user in connection with operation and control of said computer digital information processing system.

34. The method according to claim 33, wherein the step of providing said directional microphone transducer means comprises the steps of:

mounting a pressure gradient electret microphone capsule having first and second sound pressure ports within a microphone enclosure having a frontal acoustical transparency and a rear acoustical transparency,

and,

locating said microphone enclosure at an upper exterior vertex of said monitor facing the user such that said first sound pressure port is principally accessible to said speech sounds spoken by the user through said frontal transparency, and said second sound pressure port is principally accessible to a plurality of sounds waves originating from behind and from each side of said microphone housing through said rear acoustical transparency.

35. The method according to claim 34, wherein the step of locating said microphone enclosure at the upper exterior vertex of said monitor maximally preserves a sound pressure gradient existing between said first and second sound pressure ports of said microphone capsule.

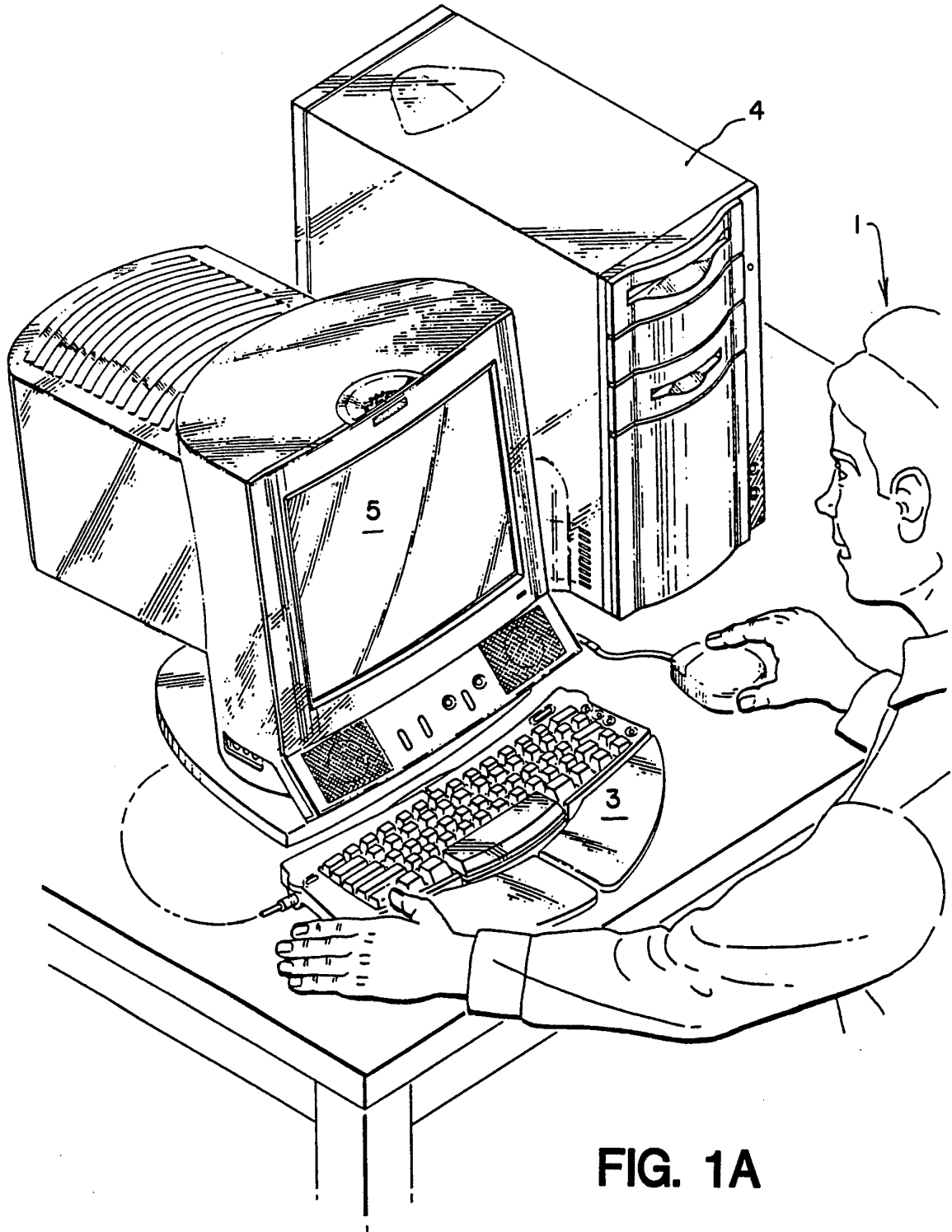

FIG. 1A

FIG. 2A

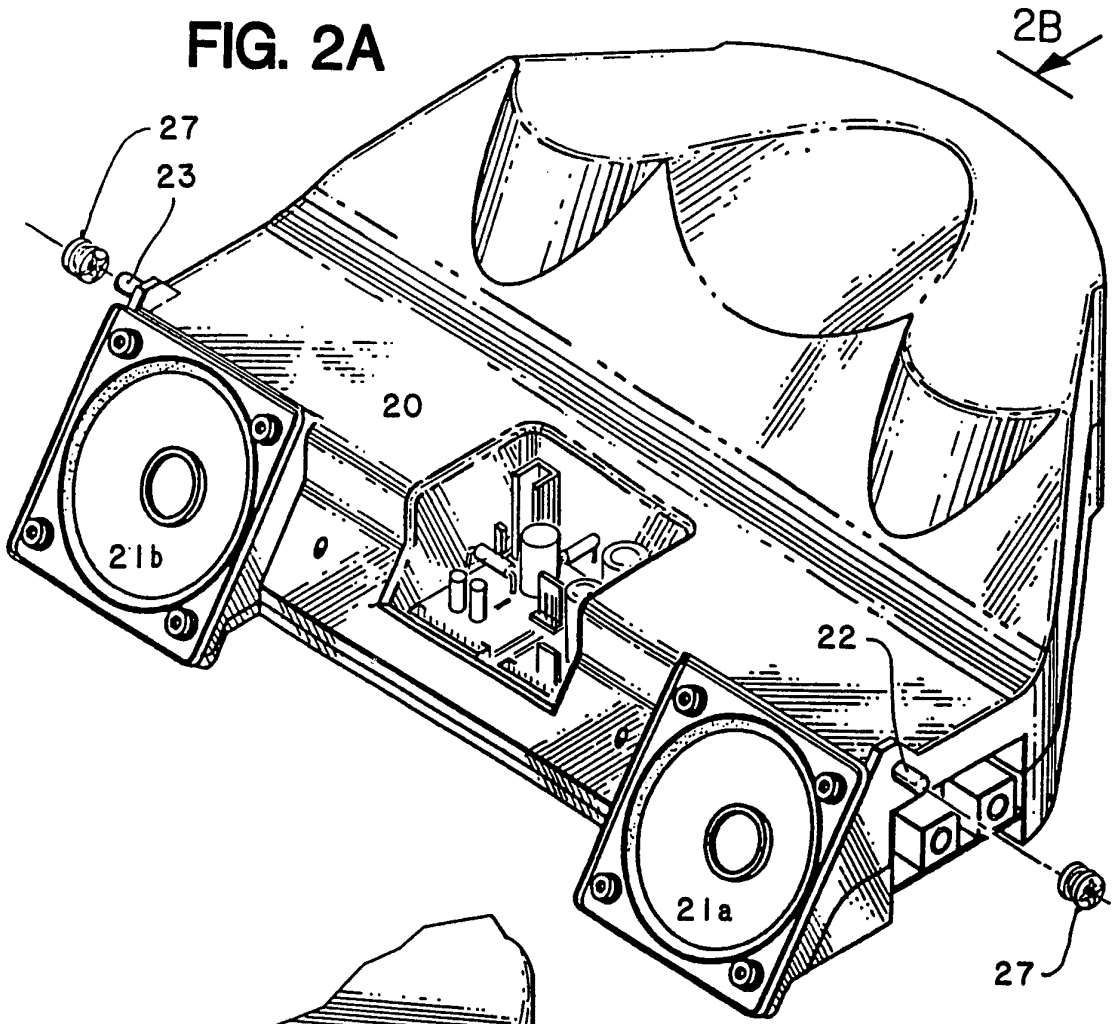
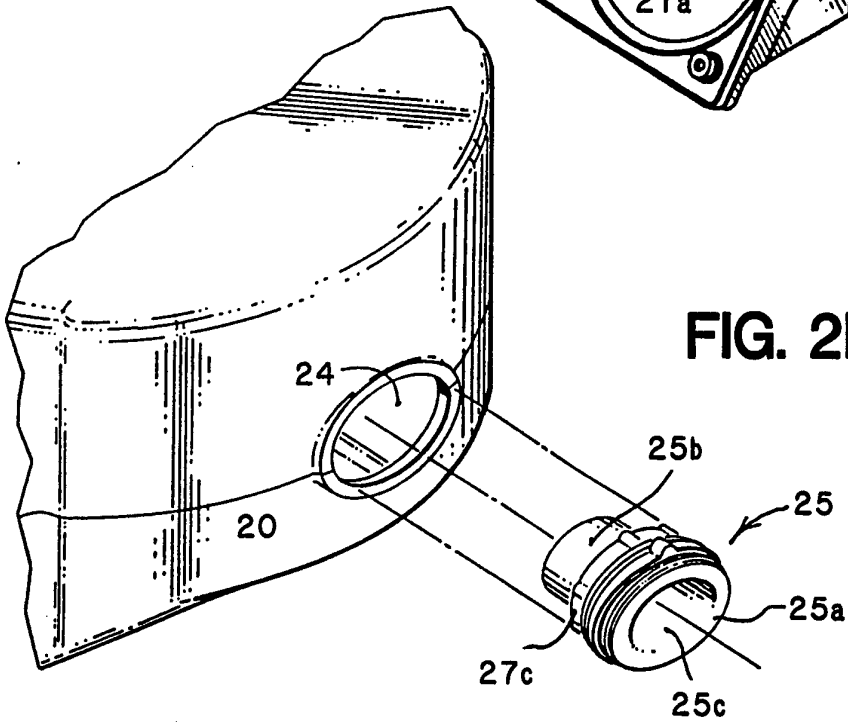
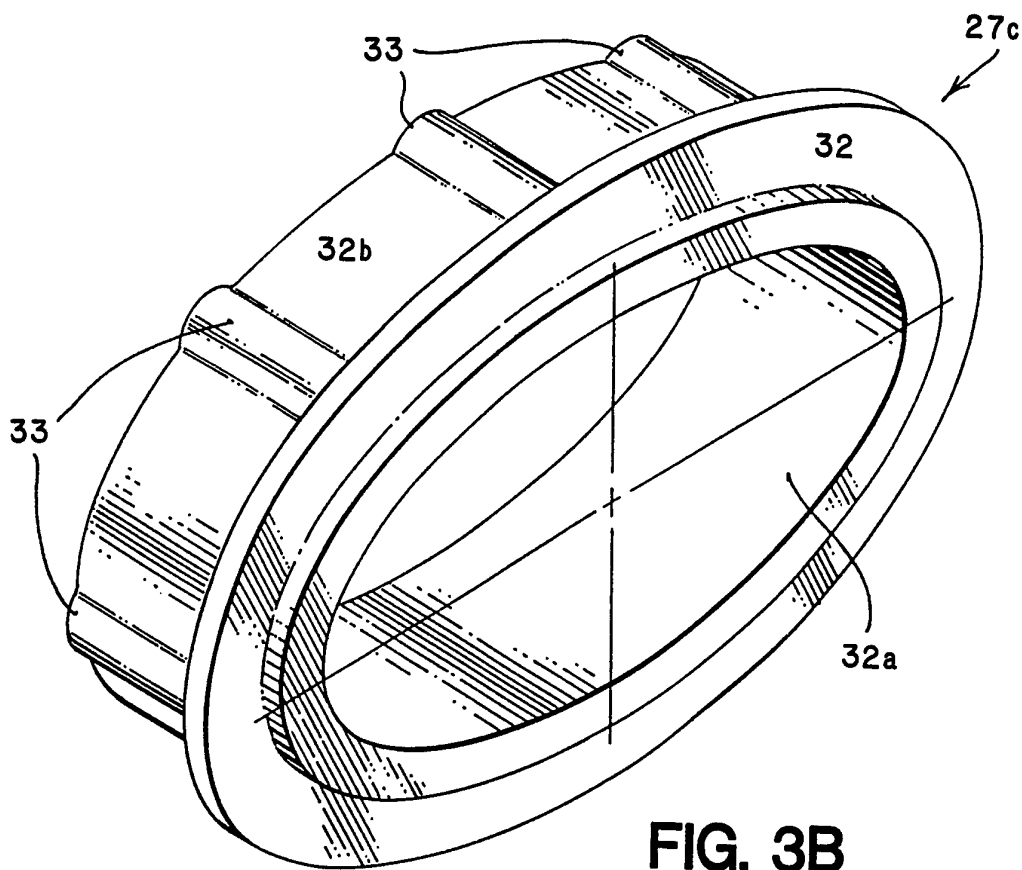
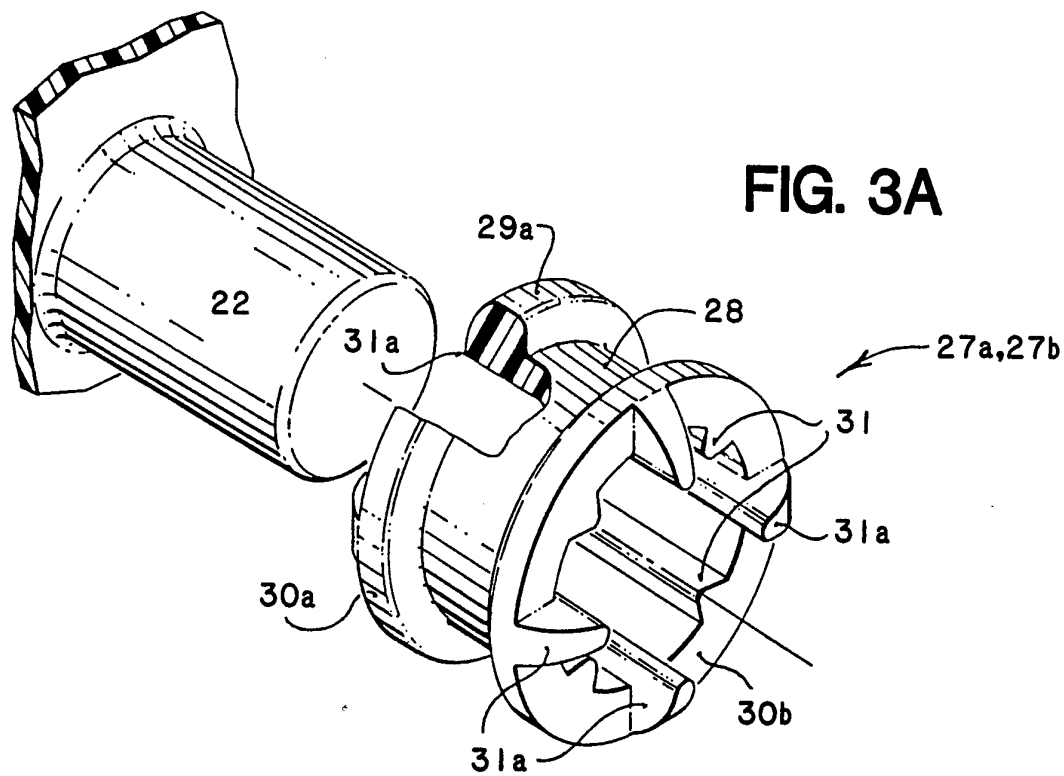

FIG. 2B





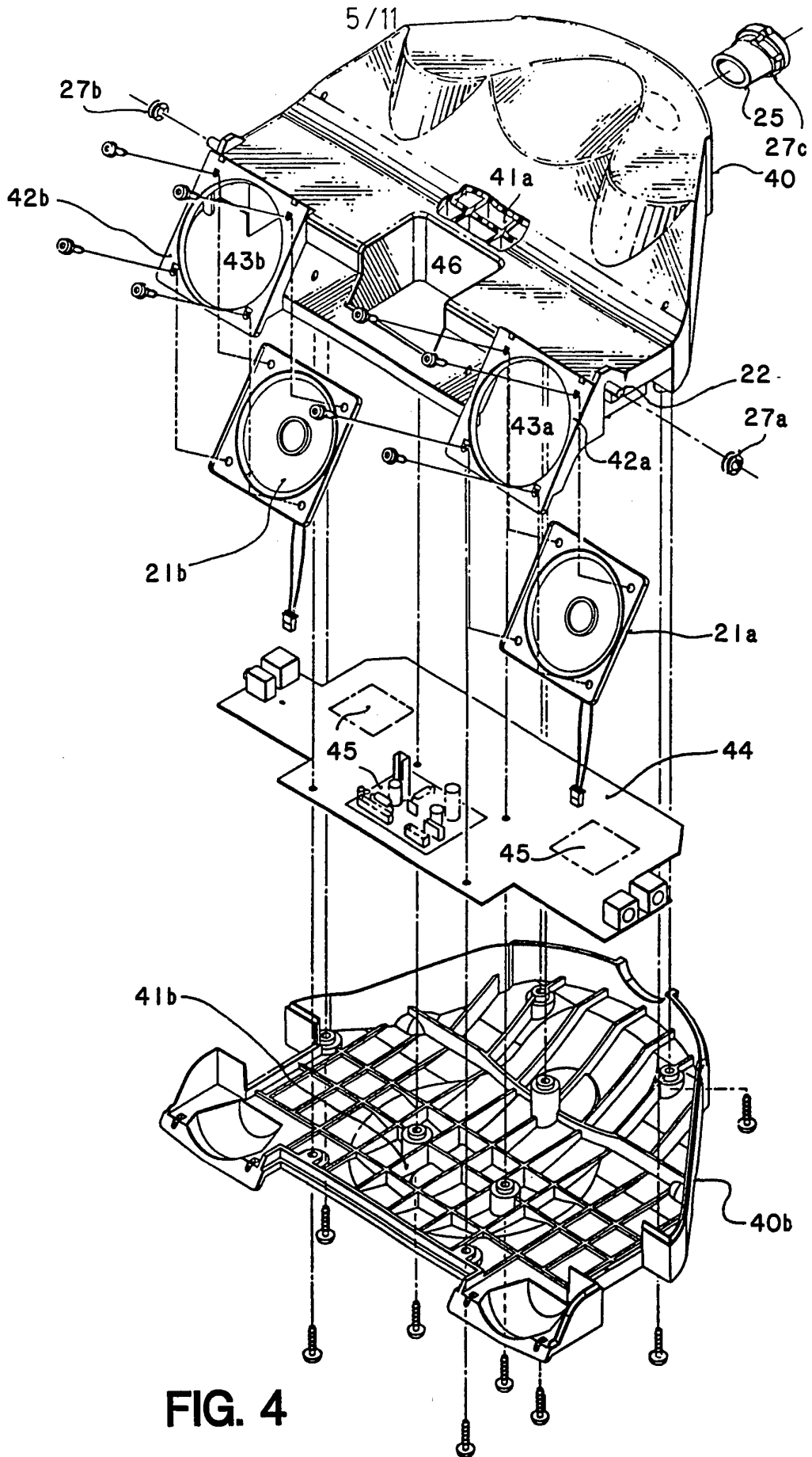

FIG. 4

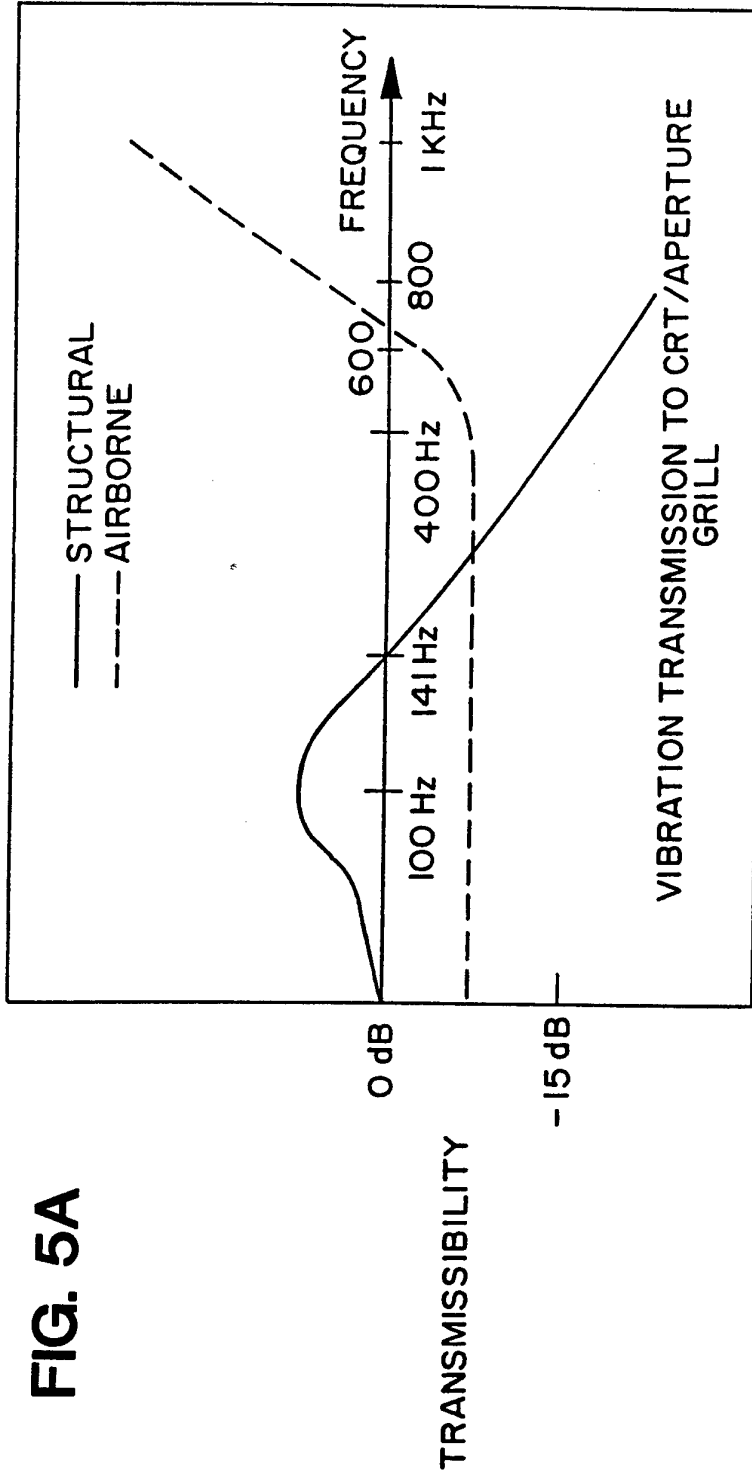
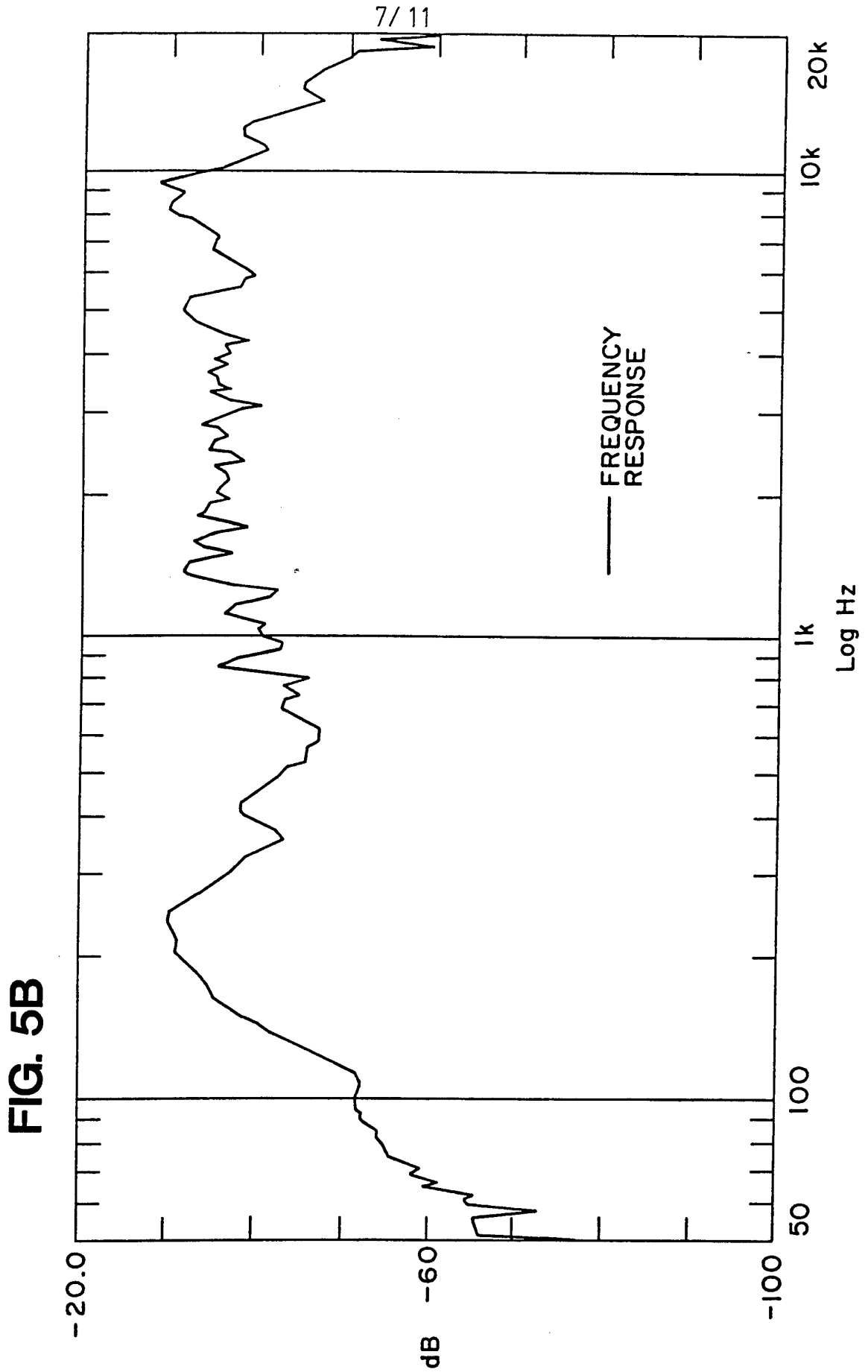

FIG. 5A



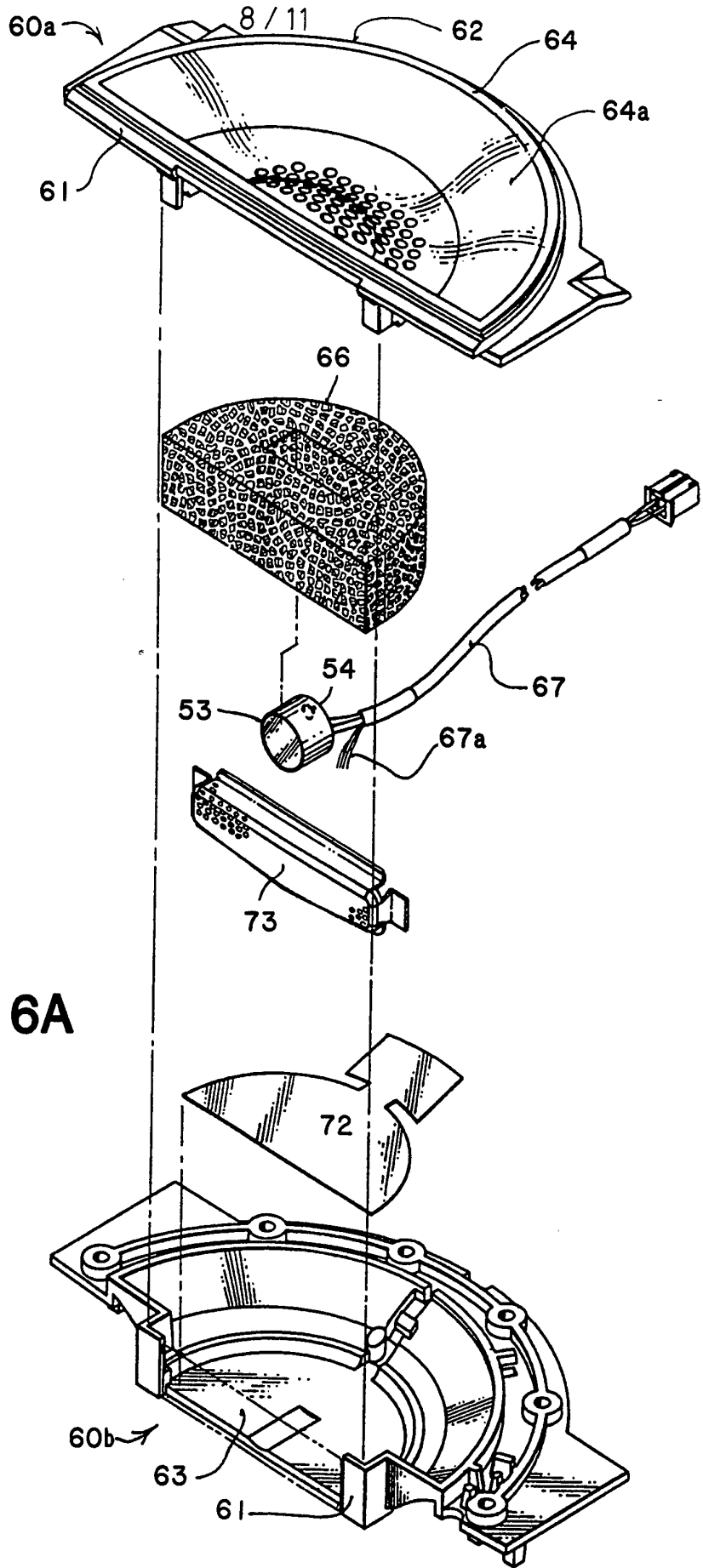

FIG. 6A

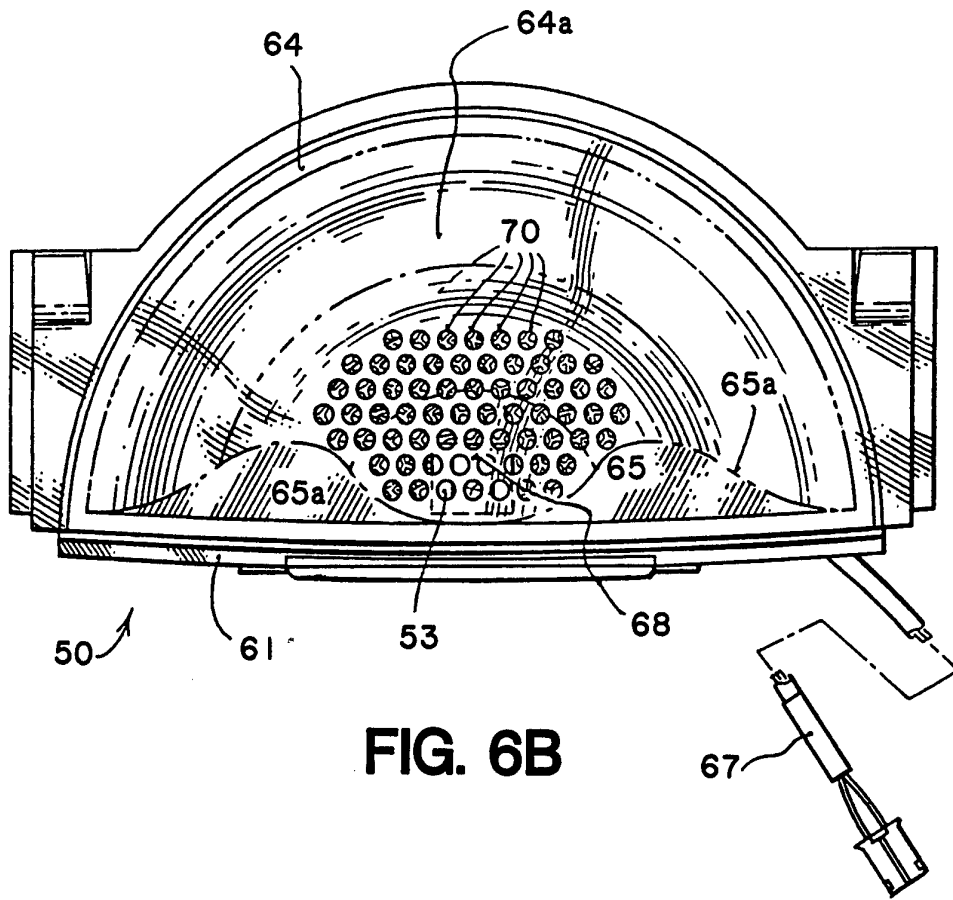

FIG. 6B

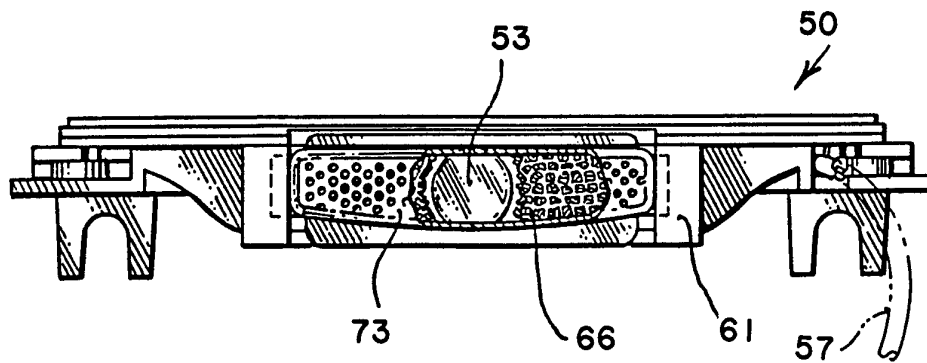

FIG. 6C

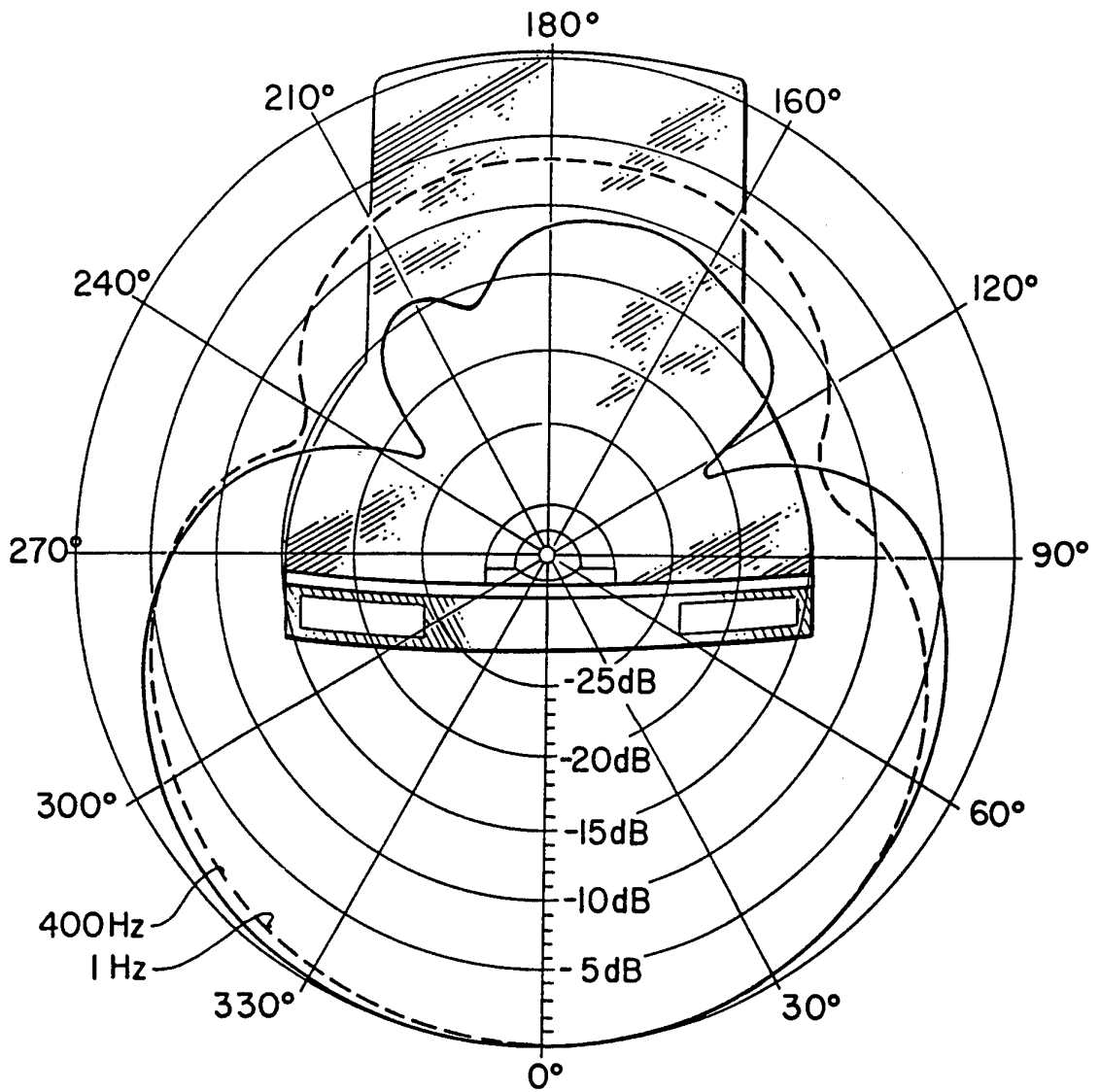

FIG. 7

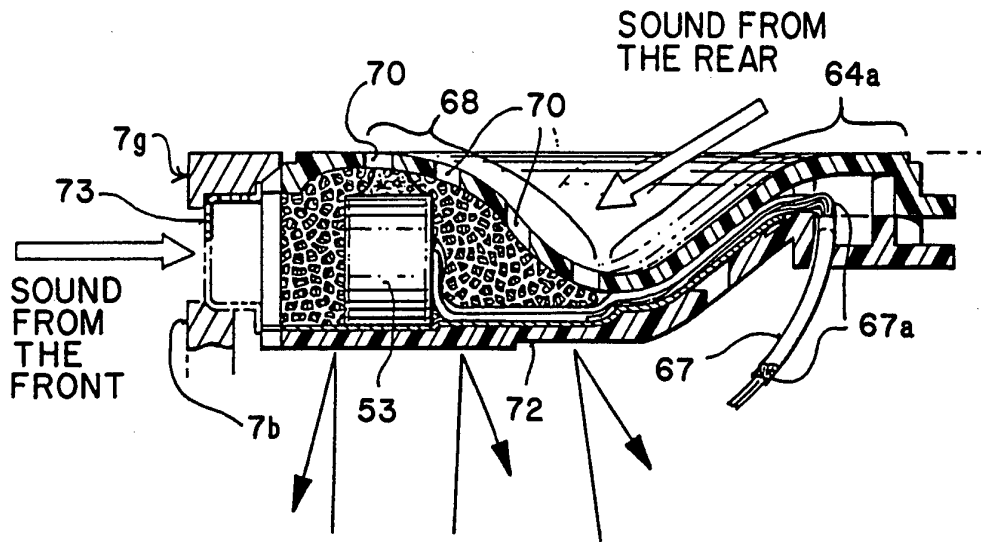

FIG. 8

INTERNATIONAL SEARCH REPORT

International Application No
PCT/US 94/07020

| | | |
|---|---|---|
| A. CLASSIFICATION OF SUBJECT MATTER IPC 5 H04R5/02 H04R1/38 | | |
| According to International Patent Classification (IPC) or to both national classification and IPC | | |
| B. FIELDS SEARCHED | | |
| Minimum documentation searched (classification system followed by classification symbols) IPC 5 H04R H04N B60J H04H | | |
| Documentation searched other than minimum documentation to the extent that such documents are included in the fields searched | | |
| Electronic data base consulted during the international search (name of data base and, where practical, search terms used) | | |
| C. DOCUMENTS CONSIDERED TO BE RELEVANT | | |
| Category * | Citation of document, with indication, where appropriate, of the relevant passages | Relevant to claim No. |
| A | PATENT ABSTRACTS OF JAPAN vol. 4 no. 122 (P-025) ,29 August 1980 & JP,A,55 076406 (HITACHI) 9 June 1980, see abstract --- | 1,2,9-12 ,14-16, 21-24,31 -35 |
| A | WO,A,92 14336 (ANALOG DEVICES) 20 August 1992 see page 1, line 1-3 see page 7, line 1 - page 8, line 4 --- | 1,16,24 |
| A | DE,A,42 39 200 (M.WÖLKI) 13 May 1993 see column 1, line 3 - column 2, line 51 --- -/-- | 1-3,9,10 ,16,17, 21,22,24 ,25,28, 31,32 |
| <input checked="" type="checkbox"/> Further documents are listed in the continuation of box C. <input checked="" type="checkbox"/> Patent family members are listed in annex. | | |
| * Special categories of cited documents : | | |
| "A" document defining the general state of the art which is not considered to be of particular relevance "E" earlier document but published on or after the international filing date "I" document which may throw doubts on priority claim(s) or which is cited to establish the publication date of another citation or other special reason (as specified) "O" document referring to an oral disclosure, use, exhibition or other means "P" document published prior to the international filing date but later than the priority date claimed | | "T" later document published after the international filing date or priority date and not in conflict with the application but cited to understand the principle or theory underlying the invention "X" document of particular relevance; the claimed invention cannot be considered novel or cannot be considered to involve an inventive step when the document is taken alone "Y" document of particular relevance; the claimed invention cannot be considered to involve an inventive step when the document is combined with one or more other such documents, such combination being obvious to a person skilled in the art. "&" document member of the same patent family |
| Date of the actual completion of the international search <p align="center">25 October 1994</p> | | Date of mailing of the international search report <p align="center">31.10.94</p> |
| Name and mailing address of the ISA European Patent Office, P.B. 5818 Patentlaan 2 NL - 2280 HV Rijswijk Tel. (+ 31-70) 340-2040, Tx. 31 651 epo nl, Fax: (+ 31-70) 340-3016 | | Authorized officer <p align="center">Zanti, P</p> |

INTERNATIONAL SEARCH REPORT

International Application No
PCT/US 94/07020

| C.(Continuation) DOCUMENTS CONSIDERED TO BE RELEVANT | | |
|--|--|--|
| Category * | Citation of document, with indication, where appropriate, of the relevant passages | Relevant to claim No. |
| A | GB,A,2 185 449 (TUDORWEBASTO) 22 July 1987 see page 1, line 36-46 see page 1, line 111 - page 2, line 26 ---- | 2,7,8,10 ,16,20, 24,29,30 ,32 |
| A | EP,A,0 347 730 (EWD) 27 December 1989 see column 4, line 8-36 ---- | 4,5,18, 26,27 |
| A | FR,A,2 678 128 (G.PIARD) 24 December 1992 see page 1, line 10 - page 2, line 11 ---- | 6,19 |
| A | US,A,4 258 235 (WATSON) 24 March 1981 see column 1, line 5-9 see column 2, line 35 - column 4, line 68 ---- | 1,11-13, 16,23,33 ,35 |
| A | EP,A,0 493 361 (AKG) 1 July 1992 see page 2, line 1-4 see page 3, line 50 - page 4, line 19 see page 4, line 32 - page 5, line 4 ----- | 12,13,23 ,35 |

INTERNATIONAL SEARCH REPORT

Information on patent family members

International Application No
PCT/US 94/07020

| Patent document cited in search report | Publication date | Patent family member(s) | Publication date |
|--|------------------|-------------------------|------------------|
| WO-A-9214336 | 20-08-92 | NONE | |
| DE-A-4239200 | 13-05-93 | NONE | |
| GB-A-2185449 | 22-07-87 | NONE | |
| EP-A-347730 | 27-12-89 | DE-A- 3821166 | 28-12-89 |
| | | DE-D- 58906924 | 24-03-94 |
| | | WO-A- 8912946 | 28-12-89 |
| | | EP-A- 0423161 | 24-04-91 |
| | | ES-T- 2049277 | 16-04-94 |
| | | JP-T- 3505955 | 19-12-91 |
| | | US-A- 5315663 | 24-05-94 |
| FR-A-2678128 | 24-12-92 | NONE | |
| US-A-4258235 | 24-03-81 | NONE | |
| EP-A-493361 | 01-07-92 | AT-B- 395275 | 10-11-92 |