

(19) (KR)
(12) (A)

(51) 。 Int. Cl.7
H01L 21/02

(11)
(43)

2003-0092090
2003 12 03

(21)	10-2003-7013758		
(22)	2003 10 21		
	2003 10 21		
(86)	PCT/US2002/11966	(87)	WO 2002/86943
(86)	2002 04 17	(87)	2002 10 31

(30) 09/840,320 2001 04 23 (US)

(71) - 5- 3-6

(72) 85233 914

(74)

:

(54)

(17) ,	(12) 가 (22)	(14) 가 (22)	,	(14) (14)	(18) 가 (20)
(13)	.	(14)		(13)	
(24a) ,	(24a) (14)	(10)	.	(10)	
	(26b)	(28)	,		

9A

, 가 , , , ,

1999 3 26
09/629,515

09/277,526 , 2000 8 1

가 (IC) (PECVD) 가 가 (kinetic energy) 가 가 가 (positively) 가 (bombard) 가 (negatively) radicals) CVD ((ECR) 가 (ICP) (ICP) 5,556,521 ICP RF ICP ICP 가 (ULSI) 200 m , ICP 가 RF 가 5,669,975 RF 'S' 가 ICP

가 ICP ,

ICP 가 (footprint) 가 ICP ,

ICP 가

ICP IC

S 가 (dependence) ,

가 ICP

1999 3 26 09/277,526 ,

ICP 가

, 200 mm

/

가 (compact) 가

가 가 가

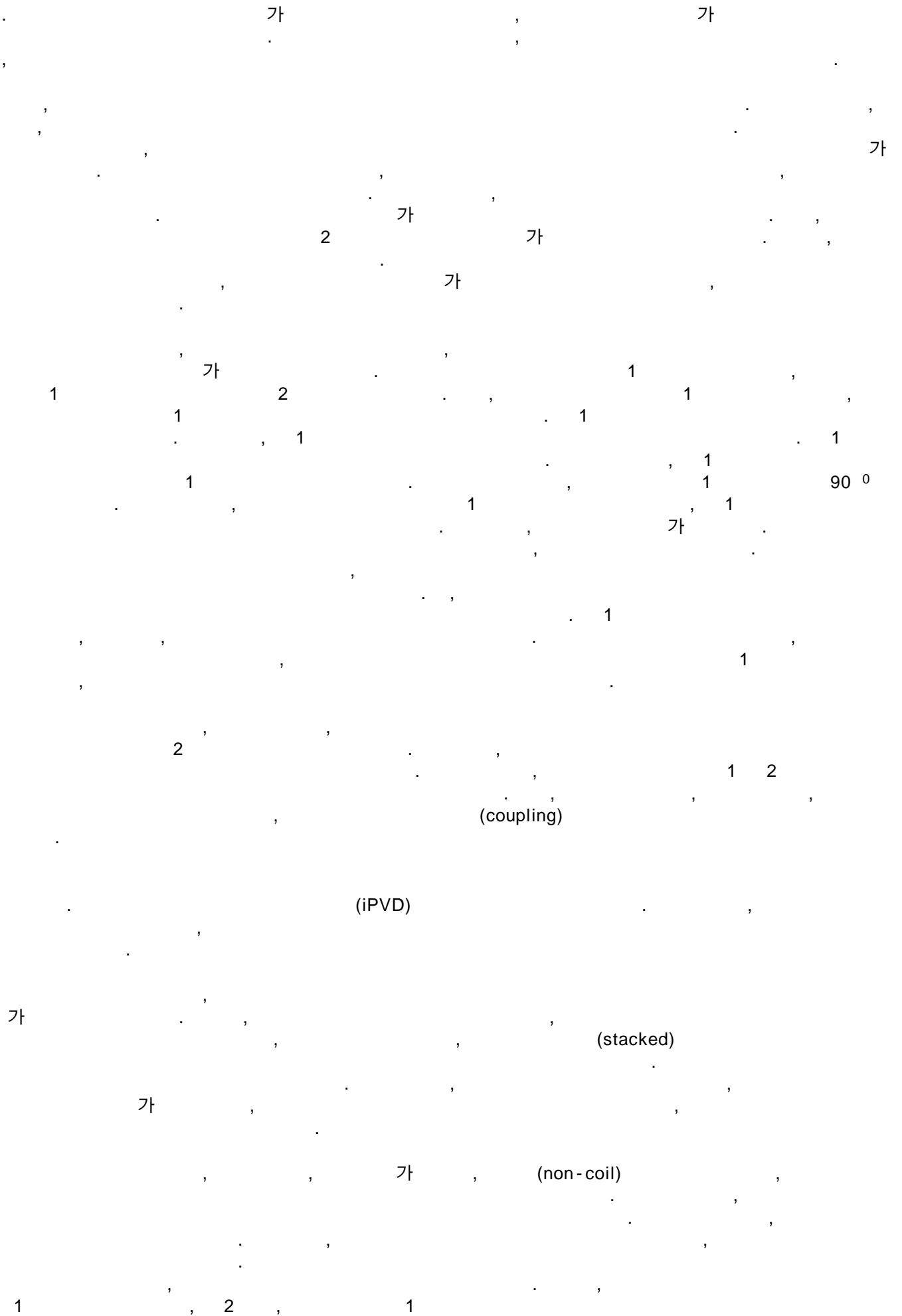

가

가

1

2

1A

1B 1A

1C

1D

1E 1

1F

2A

2B 가 2A

3A

3B 3A

4

5A

5B

6A

6B

6C

6D

7A

7B

7C

7D

8A

8B

8C

9A, 9B 9C

10A, 10B 10C

11A 11C , 가

1A , 1D
 (10) , IC ,
 CVD(PECVD) , PVD(iPVD) , (RIE)

1D (14) (13) 가 (12) (12)
 (14) (17) (16) (14) 가 (17) (18)
 가 (22) , (20) 가 (14) 가
 (19) , (17) (18)
 (10) (14) (24a)

1A (14) (10) (24a)
 (24b) 24c) (24c)
 (14) (24c)
 (matching) (26a) (10) 1D ICP (10)
 (28) RF (26b) (10) 가 RF (10) RF (26b) (10)
 (10) (18)
 (28)

(10) RF (24a) , (10)가 (24a) (30) 가 (contoured) (14) 가

(12) (24a) (10) ,

1D (14) (24a) , (13) 가 (18) (24c) (15) ,

(15, 21) (21) (13) , (14) (8A 8B) (

21) (10) (24c) 2 가 (14) (10) (

(15) , (23) , 1D (15, 21) , 1E 1E

(23) (15) (21) (24c) ,

(25) (15) (23) , 6A, 6D 7D ,

1A , (10) (32) 가

1A , (10) (34a,34b) 1D (24

a) , 1A (36) , 1D

(34a) (34b) , (38) (34a) (

36) 1 (1A), 2 2 (34b) (38) (38) 2 (34a) (

(36) (34a) (38) (34b)

1D (12) (10) , 1 (36) (10)

(34a) (30) (24a) (30) (34b)

1D 1E (38) (38) (34b) (30) 1A

(34a) (34b) (36) , 1A ,

(34b) , (38) 1A 1D

(34b) (36)

(41) (39) (10) (39) (39,41) 1A (34a) (43) (43) 가

(34a) 가 (34b)) (34a) (34b) , 1F
 S (34a) 가 (39) (41)
 (34a) 가 (35) 가 (35)
 가 (24) (13)
 가 (10) (43)
 (39) (36) (10) (10) 가 , 가
 (34b) (36) (10) , 가
 , 1A, 1B, 1D 1E .
 1A-1E, 2A-2B, 3A-3B, 4, 5A-5B 10A-10C
 가

1D 1E
 (43) (39,41)가 1E
 (10) (24a) (15) (23) (15) ()
 43) 가 (39,41) 가 1E
 (10) 가 (13) (14) (24) (13)
 가 가 1F S
 (43)
 , 1A-1E, 2A-2B, 3A-3B, 4, 5A-5B, 9C-9C 10A-10C
 (39,41) (43)
 (10) , (24) (, (34a))

(24a) (25) 가 () ()
 가 90°
 90° 가 , 1
 가,

1A (34a) (10) 1A (14)
 (28) (35) (10)
 (10) 가, (10)
 (34b) (10) (10)
 / 가 가 (43) (39)
 1A (34b) (36) (24)
 (30) (39) (10) (39)가

(10) (41) (30 41) (30 41)

(10) (spread) (constrict) (39,41)

(10) (39 41)

1B (34b) (38) (34b)

1B (38) (transition)

(34b) (38) (24a) (30)

(36)

1A (10) (34a) (36)

(34a) (36) (34b) (36)

가 (26a) RF (26b) RF 1B (42)

(42) (26a) (10) (24a) RF 1B-1D, 2A-2B, 3A-3B, 4, 5A-5B, 9A-

(36) (42)

9C 10A-10C

1A 1B (10) (24a)

1A 1B (34a) 1C (10a)

가 (43a) (1A) 가 1A-1C (34b)

가 (53) (34b)

55) (10e) 4 (53) (34a)

/ (34b)

ICP 2A 2B

RF

1A (10) (42a) (42b) (42a)

(34a) 1A RF RF (46b) (10b)

) (46a) 2A RF (48) (48) (48) (10b) 2B

(10c) 2A (10b) (45) (48) (48)

3A 가 (36,38) (10d)

가 (50a) 3A (50b) (50a)

(36) (36) (30) (3B)

(50b) (50b) (50b) (38)

(36,38) (52) (50b)

(1D) (contours) (52) (52) (50b)

(52) (10d) 가

(52)

RF

(hot spots) 가 1F S

가 (336) (338a,338b)
 , 가 , 가 2
 , (336) ,
 , (312,334)
 , , 가 , 가 , 9A-9C
 10A-10C
 11A-11C , 가 , 9A-9C 10A-10C ,
 11A 1E (340)
 1A-1F, 2A-2B, 3A-3B, 4, 5A-5B, 9A-9C 10A-10C
 (sharp curvature) 가 (tightly)
 , 90°
 11B , 가 , (344) (348)
 90° (345,346) (345,346) (349)
 11C , (350) (352) , (352) (353,35
 4) (350)가 (350) (353,354)
 90° (350) (351)
 5A 5B 3 가 가
 5A 5B 가 , 5A 5B
 가 , 5A 5B
 5A , (60) (62) (62) ,
 , 1D (62) (64) (60)가 (25)
 (62) (62) (66)
 5A 5B (62) (60) (62) ,
 (60) (66) (64) 가 (6
 2) , (66) (64)
 , (62) 5A , (62)
 가 , (60)
 (68) , (68) , 가 (60)
 (71) , 가

, 가 (62) (60) (68) 가 가 (60) (60)

, (60) (62) 5A , RF (60) (70)

) 가 (60) (62) , (60) , 1 (10)

)

5B , 1A (10) , 5A (60)

, (62) , 5A (64) (66) (72) (62)

, (72) (74) (62) (74) 5B

, (74) (62) RF 가 (76)

가 (72) 5A-5B (74) (74) 3A

3B

6A-6D

6A-6D 가

6A-6D

6A-6D 6A, 6C 6D

가

6A-6D , 가 6A-6D 가 6B

, 6B 가

6A-6D 가 , 6A-6D o

가

6A (1D) (80) , (84) (82) (80)가

(82) , 가 (84)

, (86) (82) (80), (87)

, 가 (86) (86) , (80) ,

, (84)

, (80) 가 (84) RF (crossover) (81) (80)

6B (90) , (90) (92) (92)가

(1D) , (92) (92)

(94) (92) 6B (one-and-one-half) 6B

, (92) (92) (93)

가 (96) (98) (92) (95) (92) (9)

0) (94) . RF (91) (90) .

6C (100) , , (102) (101) , (104) (103) 가 (100) 6B (108) 2 (100) (102) (106) 1 , (107) , (105) 1 2 (106) (108) (106) RF (109) (10) 00) 0) (105) 1 2 (106) (108) (106) RF (109) (10) 0) .

6D (110) , (11) 6C (114) (112) (112) , (114) 6C (114) (116) (11) (115) (113) . RF (101) 7) .

1D

가

가

가

7A (120) , (121) (122) (((123) 8B (123) 7A-7C (123)) (123) (122) (121) (120) (123) 8B (124) (126) (124) (122) (121) (127) (120) (124) , (121,122) , 가 (124) (123) (123) (121) (124) (130) RF (122) (120) (122) (121) (133) (run) (132) , (121) (134) , (122) 7A (124a) , (124b) (124) (123) (124b) (122) (124a) , (124b) RF (135) 가 (124b) (122) (123) (124b) (122) (123) (123) , RF (136) , 가 (123) (123) (120) 가 ,

7A (bend) (132,134) (122) (133) (132,134) 7A ,가 90
 7B 140) , 7A (120) (123) (122) (121) (142) (134) (133) (133,134) 90 0
 (123) (134,133) (142) (140)
 7C 7C (150) , 7A,7B (123) ,가
 (122) (121) 가 2
 7A, 7B 7C (120,140,150)
 CP 7A-7C , RF ,가 , I
 가 (121) 가
 7D , (160) , 7A-7C
 (160) 6A-6D (160) 6A-6D
 (160)가
 (161) (162) (163)
 (164) (166) (164)
 (122) (166) (121)
 (160) , 7D 6A (80)
 (121) (167) (160) (166)
 CVD) ICP CVD (PE
 2
 8A (206) (204) (202)
 (200) , (200) ,
 가 PVD (206) , (208)
 206) (204) (210) (206b) (208) (212), (208)
 (206a) (215) (210) (214) (212) (213) (214)
 (213) (214) (214) (212) DC (226b) (216)
 (216) (212) (214) (220)

(220) , 1A 8A (10) ,
(234,236) 1D (200) (10)
(222) (224) (224) (216)
(225) (220) (204) (214) ,
(216) (204) ,
206) (220) (226a) RF (226) (214) DC (226b)
) 8A (220) 1A 1B
(216) 1C,2A-2B,3A-3B,4,5A-5B,6A-6D 9-10 (200)
(216) .
(230)가 (210) (204) , 2 (230)
(232) RF (226) . 2 RF (226,232) (232a) RF (232)
(220) 2 (230)
2 PVD PVD(iPVD) (200) PVD (, AI) 1
PVD 가 , iPVD 2
가 1 , iPVD (quench) , 1 가
, 가 , 가 ,
8A , (220 230)
, 1 2 (220) (214)
(206) , 가 (214) , 1
가 , 가 2 (230) ,
, , (206) 2 (230) , 1 (230)
(202) , (214)
가 , 2 (230) RF 가 ,
가, (210)
, 1 13.56 MHZ RF (226) , 2 RF (232)
2 MHZ (226,232) 가 RF (226a,232a) , 400 kHz 100 MHZ
, RF ,
8A , 2 , 2
, 8A (200) , (206) 가 , (214)
, (200) , 가
, 2 가 , 1 2
, 가 ,

(200) (214) (strike)

212) (213) , 1 (220)

(reflect) , 가 (204) 가 , '가

8A (214) , , (constraints) , '가

), , 가 (234) , 2 (200) , (216)

(236) PVD (230) (210)

(230) , (220)

8B , 1 2 (200)

0) , (245) 7A-7D 1 (25)

, (251) (252) (246)

, (247) , (251) (252) 가 (248) 8A

, (250) (248) , (254) (255) (248)

5b) , (250) (248) , (254) (246)

, (254) DC (25)

, 7B 8B

, 가 , 7A,7C 7D

5) , 8B (245) (250) , 7A,7C 7D

, 2 (257) (256a) RF (256) (255a) RF (25)

(258) , (245) (261) (246) (260)

2 (257) (246) , (260)

(261) (260b) , (260a) , (260)

8B (245) , 가, (250)

(250) (248) (254) , 8B , (254) ,

(259)

8C , 1 2 (270) , (270) ,

, 4,5A-5B 6A-6D 1 (280)

(270) , (274) (275) (272) , (275) (274)

b) , (274a) , (274)

, (276) , (277), (279) (278)가 (274)

, DC (282b) (277) , (280) (278)

, (272) , (280) (278)

RF (282) , (283) (278) (282a)

(280)

(286) 2 (285) , 8A 8B

, (288) (285) , (288)

(288) (286) , 8C

(285) (290a) RF (272) , (272)

, 8C , (288) U

, 가 , 8A,8B

(270)

가

가
가 . 가

(57)

1.

가 가
가 가
가 가
가 가

1

1

2

2.

1

1

3.

1

1 2

3

4.

1

2

가

5.

1

가

2

가

6.

1

(shield)

6 7.

6 8.

9.

가 ,

가

가

1

1

2

9 10.

1 2

3

9 11.

2

가

9 12.

가

2

가

13.

가 ,

가

가

1

1

2

14.
13 ,
1

15.
13 ,

2 가 ,

16.
13 ,

가 2 가 ,

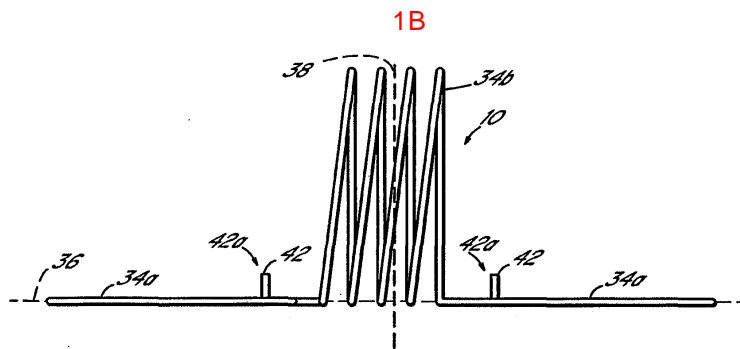
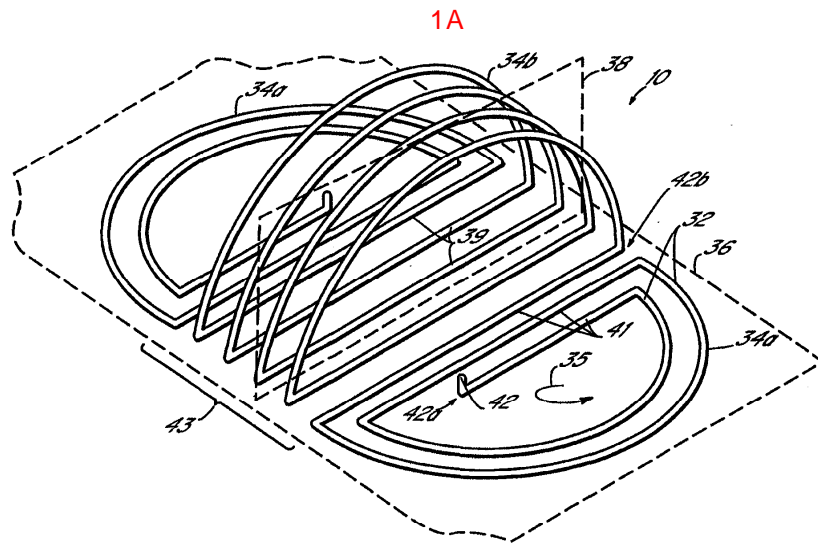

1C

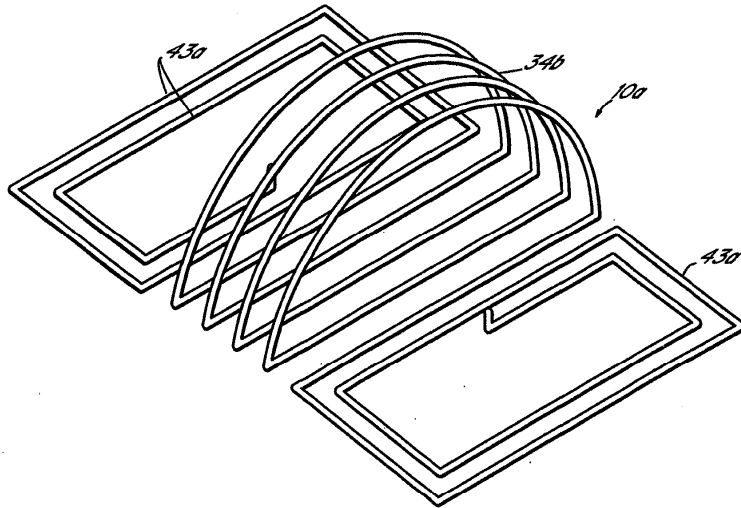

1D

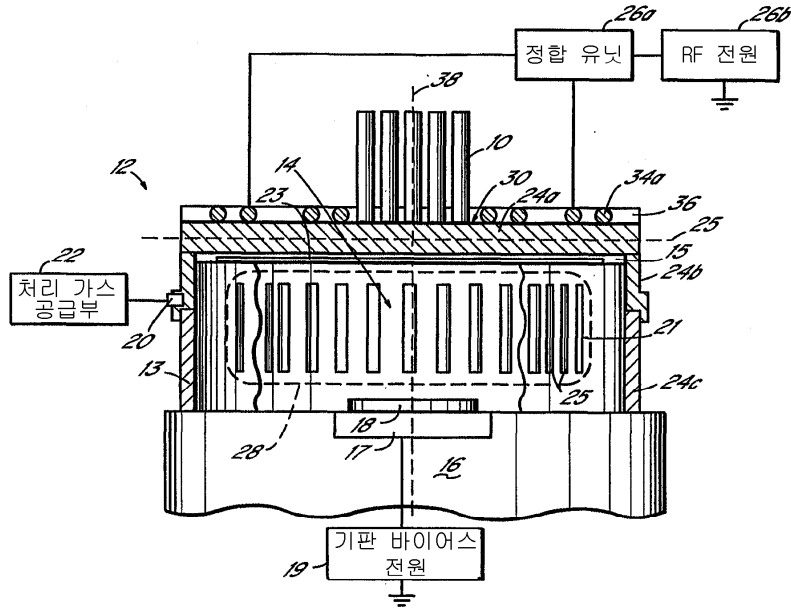

1E

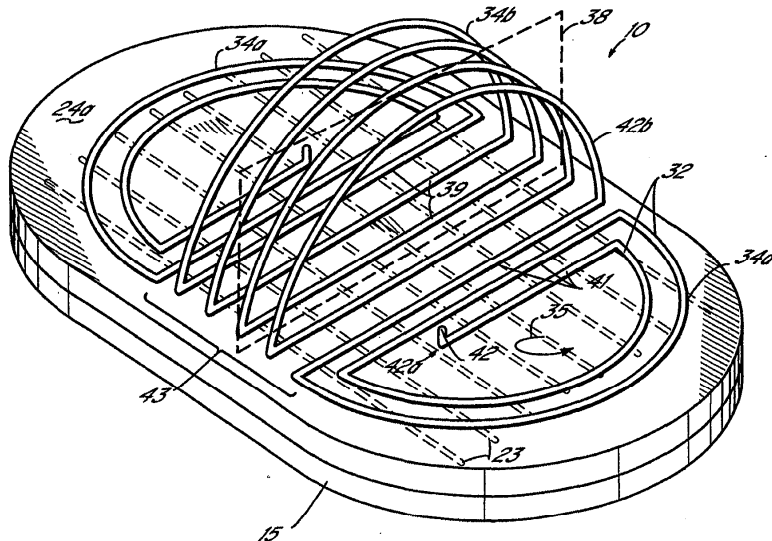

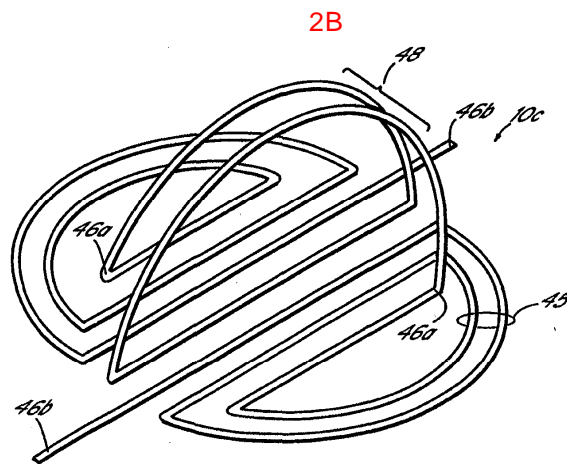
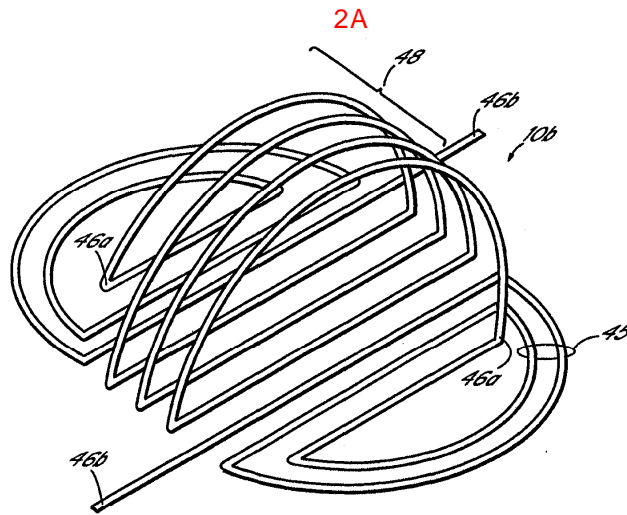
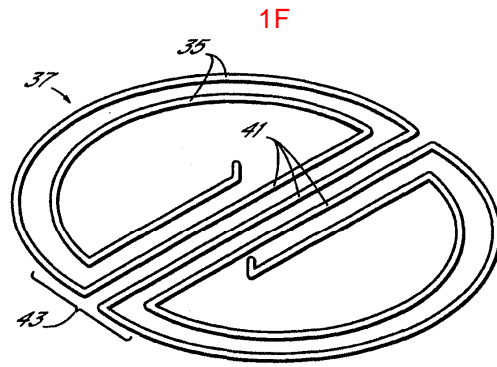

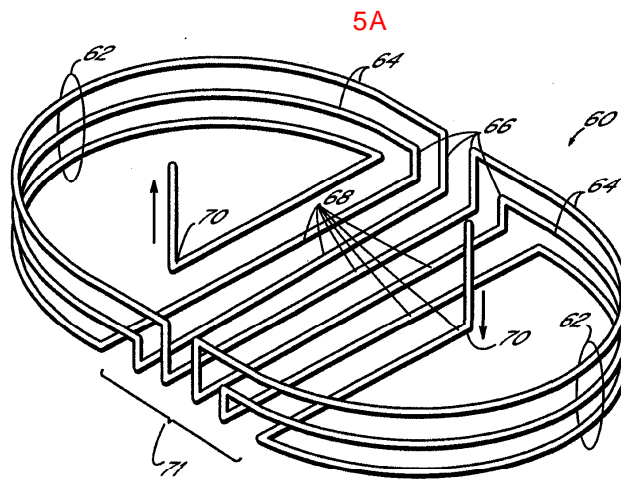
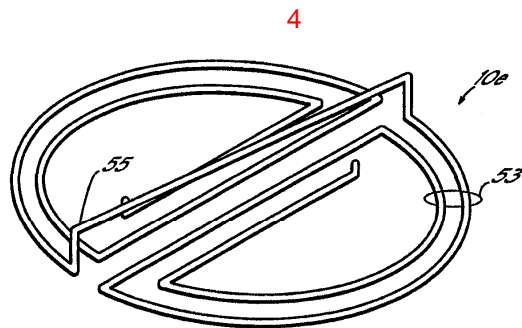
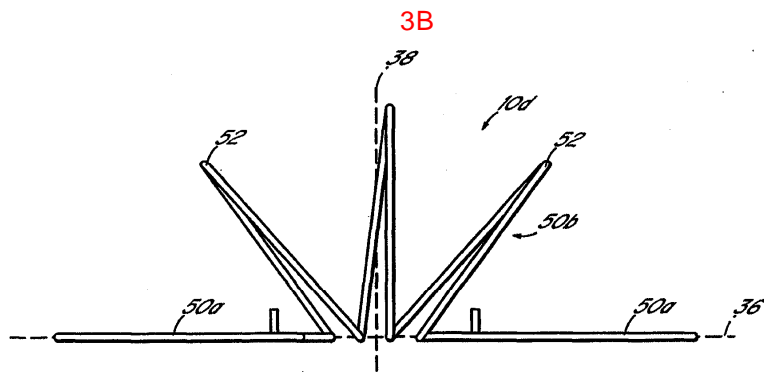
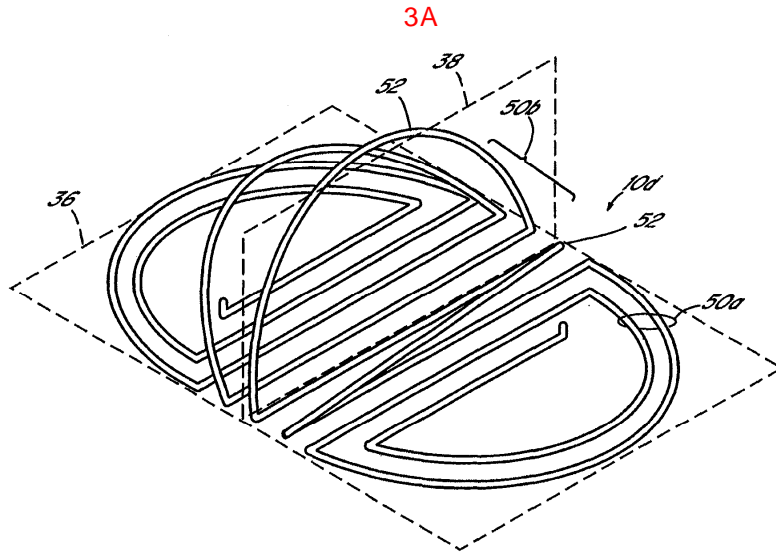

6C

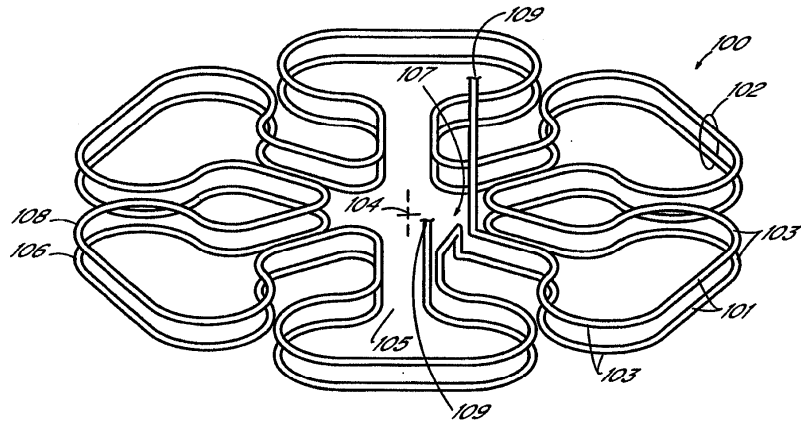

6D

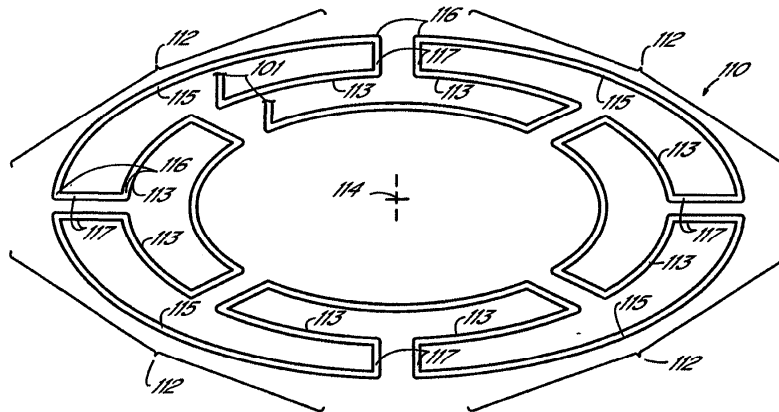

7A

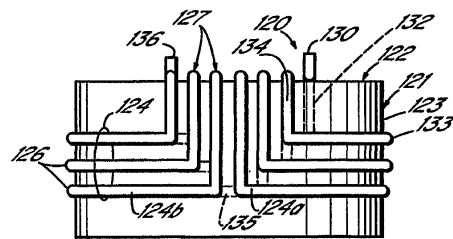

7B

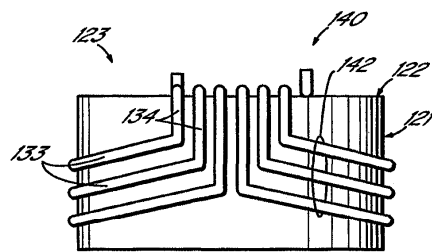

7C

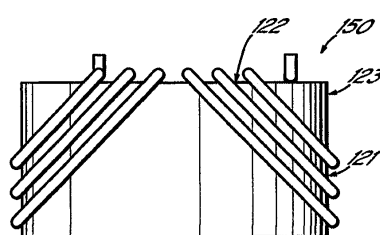

7D

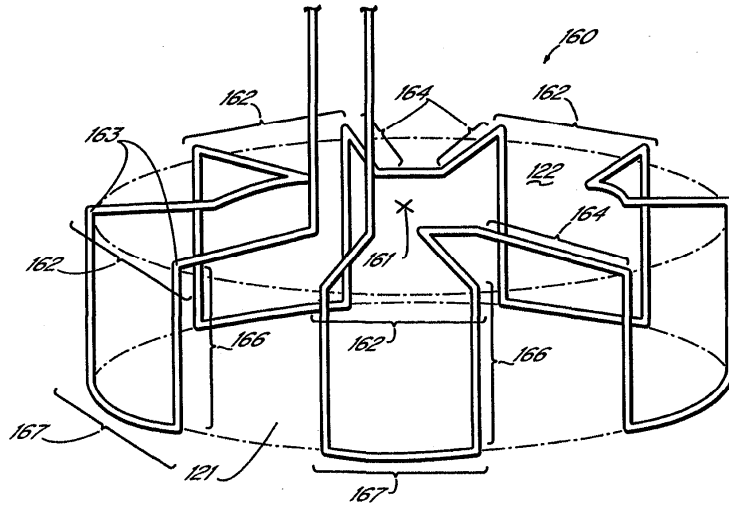

8A

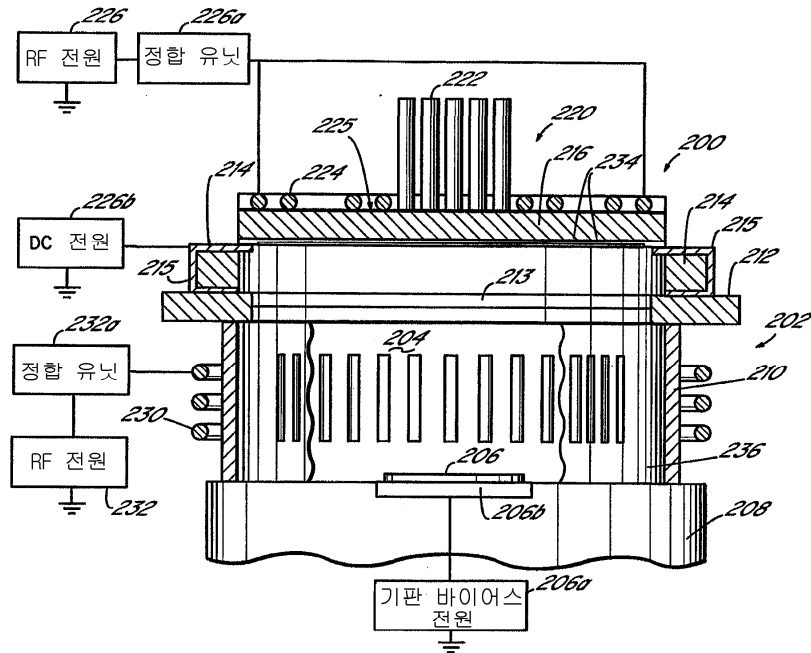

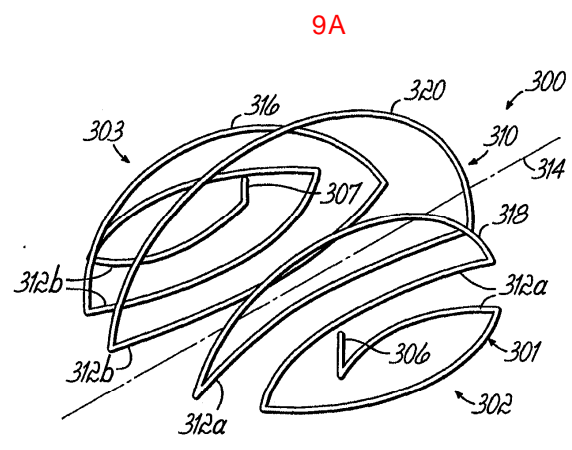
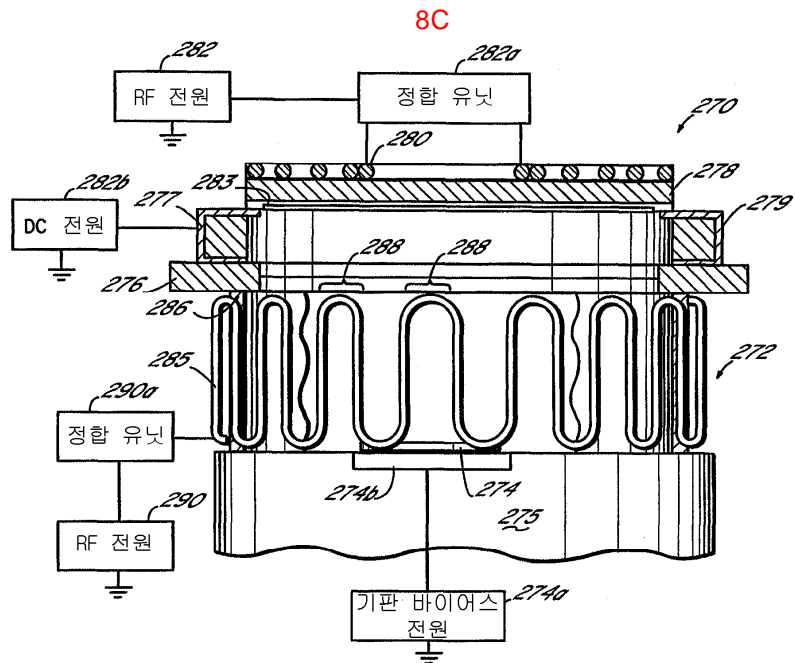
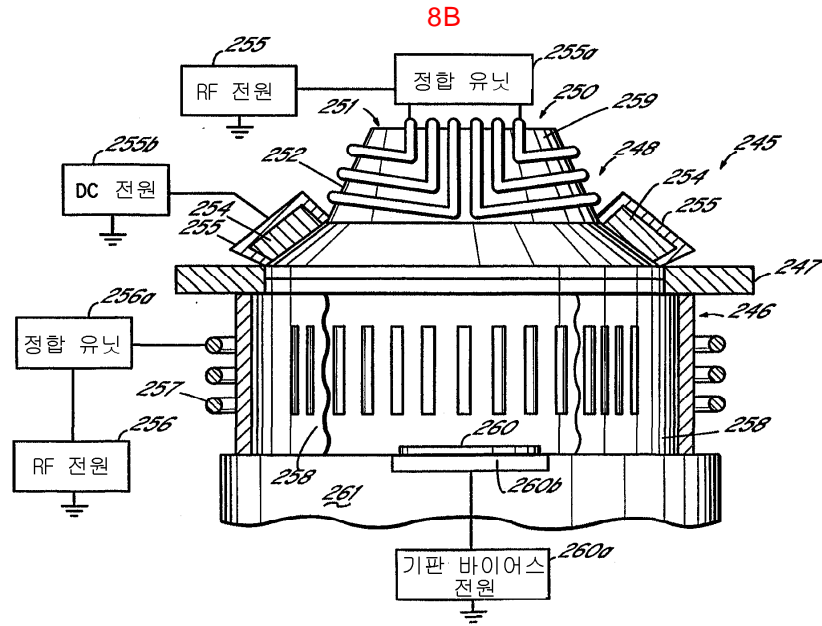

9B

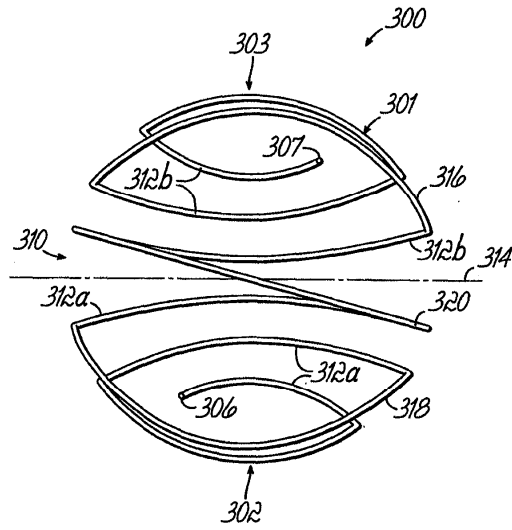

9C

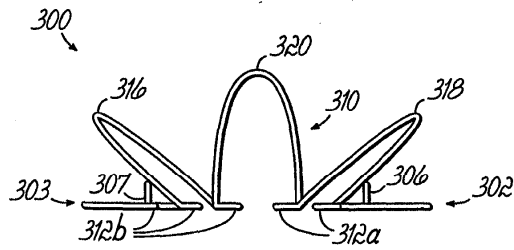

10A

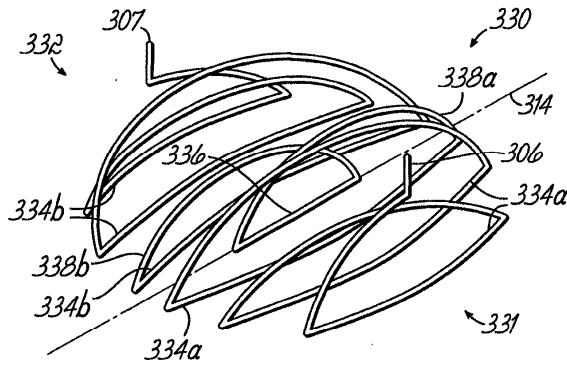

10B

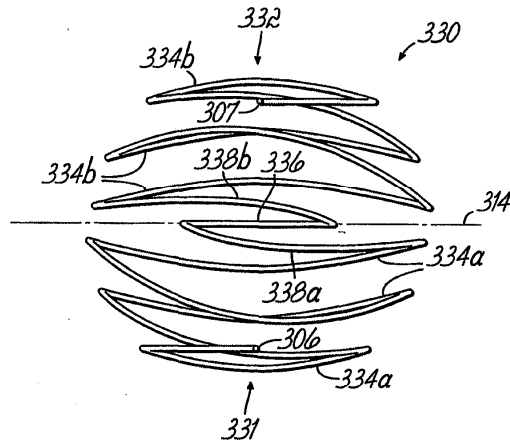

10C

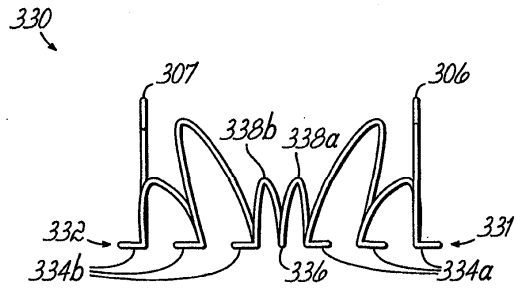

11A

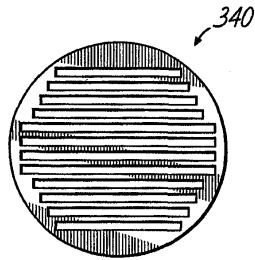

11B

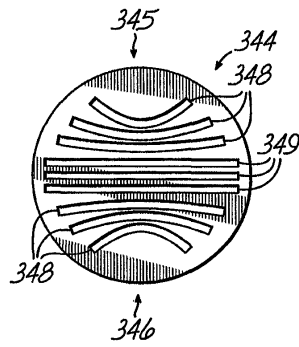

11C

