



- (51) International Patent Classification:
A01N 1/02 (2006.01)
- (21) International Application Number:
PCT/US2014/019537
- (22) International Filing Date:
28 February 2014 (28.02.2014)
- (25) Filing Language:
English
- (26) Publication Language:
English
- (30) Priority Data:
61/770,516 28 February 2013 (28.02.2013) US
- (71) Applicant: NEW HEALTH SCIENCES, INC. [US/US];
6903 Rockledge Drive, Suite 230, Bethesda, Maryland
20817-1818 (US).
- (72) Inventors: LEVESQUE, Steven F.; P.O. Box 514, North
Pembroke, Massachusetts 02358 (US). RUTH, Thomas
R.; 8 Oldfield Drive, South Easton, Massachusetts 02375
(US).

(74) Agents: ALTMANN, Curtis R. et al.; 555 12th Street,
NW, Washington, District of Columbia, District of
Columbia 20004-1206 (US).

(81) Designated States (unless otherwise indicated, for every
kind of national protection available): AE, AG, AL, AM,
AO, AT, AU, AZ, BA, BB, BG, BH, BN, BR, BW, BY,
BZ, CA, CH, CL, CN, CO, CR, CU, CZ, DE, DK, DM,
DO, DZ, EC, EE, EG, ES, FI, GB, GD, GE, GH, GM, GT,
HN, HR, HU, ID, IL, IN, IR, IS, JP, KE, KG, KN, KP, KR,
KZ, LA, LC, LK, LR, LS, LT, LU, LY, MA, MD, ME,
MG, MK, MN, MW, MX, MY, MZ, NA, NG, NI, NO, NZ,
OM, PA, PE, PG, PH, PL, PT, QA, RO, RS, RU, RW, SA,
SC, SD, SE, SG, SK, SL, SM, ST, SV, SY, TH, TJ, TM,
TN, TR, TT, TZ, UA, UG, US, UZ, VC, VN, ZA, ZM,
ZW.

(84) Designated States (unless otherwise indicated, for every
kind of regional protection available): ARIPO (BW, GH,
GM, KE, LR, LS, MW, MZ, NA, RW, SD, SL, SZ, TZ,
UG, ZM, ZW), Eurasian (AM, AZ, BY, KG, KZ, RU, TJ,
TM), European (AL, AT, BE, BG, CH, CY, CZ, DE, DK,

[Continued on next page]

(54) Title: GAS DEPLETION AND GAS ADDITION DEVICES FOR BLOOD TREATMENT

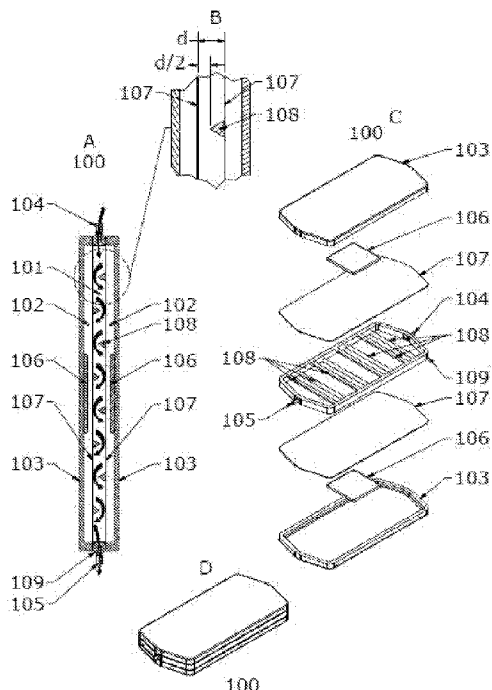

FIG. 1

(57) Abstract: Devices for the preparation of depleted blood products that provide for the depletion of oxygen, carbon dioxide, or oxygen and carbon dioxide are described. A depletion device (100) comprises an enclosure (103), one or more liquid chambers (101) and one or more depletion chambers (102). A gas permeable barrier (107) separates the liquid chamber(s) from the depletion chamber(s). The depletion chamber contains depletion media (106) such as a solid O₂ and CO₂ sorbent combination. The depletion chamber may also comprise a gas inlet and a gas outlet through which a depletion gas such as argon may enter and exit the device. The liquid chamber may comprise flow control features (108) that direct the flow of liquid against the gas permeable barrier(s). In addition, devices for the replenishment of oxygen and other gases to an anaerobic blood product are described.

WO 2014/134503 A1

EE, ES, FI, FR, GB, GR, HR, HU, IE, IS, IT, LT, LU,
LV, MC, MK, MT, NL, NO, PL, PT, RO, RS, SE, SI, SK,
SM, TR), OAPI (BF, BJ, CF, CG, CI, CM, GA, GN, GQ,
GW, KM, ML, MR, NE, SN, TD, TG).

— *before the expiration of the time limit for amending the
claims and to be republished in the event of receipt of
amendments (Rule 48.2(h))*

Published:

— *with international search report (Art. 21(3))*

GAS DEPLETION AND GAS ADDITION DEVICES FOR BLOOD TREATMENT

BACKGROUND OF THE INVENTION

Field of the Invention

5 [0001] The present disclosure includes to the devices, methods and systems for the preservation of blood products and red blood cells. More particularly, the disclosure includes devices for the removal of gases from the systems and methods for the prolonged anaerobic storage of red blood cells from blood products and the restoration of gases to blood products prior to transfusion. The disclosure also provides for devices to restore gases prior to
10 transfusion.

BACKGROUND OF THE INVENTION

[0002] Supplies of liquid blood are currently limited by storage systems used in conventional blood storage practice. Using current systems, stored blood expires after a period of about 42 days of refrigerated storage at a temperature above freezing (*i.e.*, 4°C) as packed
15 blood cell preparations. Deterioration occurs even before day 42. Expired blood cannot be used and must be discarded because it will harm the ultimate recipient. One of the primary reasons for blood spoilage is its continued metabolic activity after it is stored. For example, in 2007, more than 45 million units of red blood cells (RBCs) were collected and stored globally (15.6 million in the US). During refrigerated storage, RBCs become progressively damaged by
20 storage lesions. When transfused within the current 6-week limit, stored RBCs have lower quality (fraction of RBC removed; compromised O₂ delivery capacity) as well as potential toxicity, often manifested as side effects of transfusion therapy. These storage lesions are observed as altered biochemical and physical parameters associated with stored cells. Examples of these include *in vitro* measured parameters such as reduced metabolite levels (ATP and 2,3-
25 DPG), reduced surface area, echinocytosis, phosphatidylserine exposure, and reduced deformability.

[0003] Stored blood undergoes steady deterioration which is partly caused by hemolysis, hemoglobin degradation and reduced adenosine triphosphate (ATP) concentration that occur during the storage period. These reasons and others limit the amount of readily available high
30 quality blood needed for transfusions.

[0004] As discussed above, when RBCs are stored under refrigeration at temperatures above freezing (*e.g.*, 1-6°C, standard storage conditions) in a blood storage bag, away from mechanical stress and the constantly cycling environment of the circulation, the senescence process is partially suspended. However, with the lack of constant nutrient replenishment and waste removal under refrigerated storage, RBCs are gradually damaged, resulting in compromised physiological functions. By way of example, the following problems occur during extended storage:

- When RBCs are stored for an extended period, storage lesions accumulate and deteriorate RBCs and cause the up to 1% of RBCs to be hemolyzed during storage and up to 25% to be removed shortly after transfusion.
- Non-viable RBCs cause iron overload in chronically transfused patients.
- Transfusion does not always achieve the intended outcome of increased tissue perfusion.
- Hemoglobin in RBCs do not release oxygen efficiently at tissues due to loss of 2,3-DPG.
- RBCs are not able to enter and perfuse capillary beds due to loss of deformability.

[0005] Transfusing RBCs stored for longer periods may result in higher morbidity and longer hospital stays compared to transfusing “fresher” red cells. Higher morbidity and longer hospital stays result with RBCs that are stored longer than 6 weeks, in comparison to fresher red cells. For example, negative clinical outcomes in cardiac surgery occur when using “older” blood; multiple organ failure in surgical patients reflecting the age of transfused red cells; correlation between older units and increased mortality in severe sepsis; failure to improve O₂ utilization attributed to decreased 2,3-DPG and decreased cardiac index associated with increased blood viscosity.

[0006] The ineffectiveness and negative consequences of transfusion are attributed at least in part to the compromising effects of extended storage of RBCs. In addition to immediate removal by the recipient of certain RBCs, consequences of RBC storage lesions include: (i) depletion of ATP (loss of RBC’s ability to dilate the pre-capillary arteriole); (ii) depletion of 2,3-DPG; (iii) accumulation of oxidative damage caused by reactive oxygen species (ROS) formed by the reaction of denatured hemoglobin with O₂; and (iv) decreased RBC deformability and increased RBC viscosity caused in part by oxidative damage to membrane and cytoskeleton.

Less deformable RBCs are excluded from capillary channels resulting in low capillary occupancy and reduced tissue perfusion. Massive transfusion of undeformable cells may also contribute to multiple organ failure by blocking the organs' capillary beds. After transfusion, 2,3-DPG is synthesized relatively quickly *in vivo* to ~50% of the normal level in as little as 7
5 hours and to ~95% of the normal level in 2-3 days. However, since 2,3-DPG-depleted cells do not recover their levels immediately, O₂-carrying capacity is compromised to the detriment of critically ill patients requiring immediate O₂ delivery and tissue perfusion. There are numerous reports that emphasize the importance of RBCs with high oxygen carrying capacity in such clinical situations.

10 [0007] Storage of frozen blood is known in the art, but such frozen blood has limitations. For a number of years, frozen blood has been used by blood banks and the military for certain high-demand and rare types of blood. However, frozen blood is difficult to handle. It must be thawed which makes it impractical for emergency situations. Once blood is thawed, it must be used within 48 hours. U.S. Patent No. 6,413,713 to Serebrennikov is directed to a method of
15 storing blood at temperatures below 0°C.

[0008] U.S. Patent No. 4,769,318 to Hamasaki *et al.* and U.S. Patent No. 4,880,786 to Sasakawa *et al.* are directed to additive solutions for blood preservation and activation. U.S. Patent No. 5,624,794 to Bitensky *et al.*, U.S. Patent No. 6,162,396 to Bitensky *et al.*, and U.S. Patent No. 5,476,764 to Bitensky are directed to the storage of red blood cells under oxygen-
20 depleted conditions. U.S. Patent No. 5,789,151 to Bitensky *et al.* is directed to blood storage additive solutions.

[0009] Additive solutions for blood preservation and activation are known in the art. For example, Rejuvesol™ (available from enCyte Corp., Braintree, MA) is added to blood after cold storage (*i.e.*, 4°C) just prior to transfusion or prior to freezing (*i.e.*, at -80°C with glycerol) for
25 extended storage. U.S. Patent No. 6,447,987 to Hess *et al.* is directed to additive solutions for the refrigerated storage of human red blood cells.

[0010] The effects of elevation and preservation of ATP levels in blood storage situations has been studied. For example, in "Studies In Red Blood Cell Preservation-7. *In Vivo* and *in Vitro* Studies with a Modified Phosphate-Ammonium Additive Solution," by Greenwalt *et al.*,
30 Vox Sang 65, 87-94 (1993), the authors determined that the experimental additive solution (EAS-2) containing in mM: 20 NH₄Cl, 30 Na₂HPO₄, 2 adenine, 110 dextrose, 55 mannitol, pH

7.15, is useful in extending the storage shelf-life of human RBCs from the current standard of 5-6 weeks to an improved standard of 8-9 weeks. Packed RBCs are suitable for transfusion following the removal of the supernatant with a single washing step. Greenwalt *et al.* also conclude that factors other than ATP concentration appear to play an increasingly important role in determining RBC viability after 50 days of storage. They cite the results of L. Wood and E. Beutler in “The Viability of Human Blood Stored in Phosphate Adenine Media,” *Transfusion* 7, 401-408 (1967), and find in their own experiments that the relationship between ATP concentration and 24-hour RBC survival measurements appears to become less clear after about 8 weeks of storage. E. Beutler and C. West restate that the relationship between red cell ATP concentration and viability is a weak one after prolonged periods of storage in “Storage of Red Cell Concentrates in CPD-A2 for 42 and 49 Days,” *J. Lab. Clin. Med.* 102, 53-62 (1983).

[0011] Certain patents have addressed different aspects of blood storage. One such patent is U.S. Patent No. 4,837,047 to Sato *et al.* which relates to a container for storing blood for a long period of time to keep the quality of the blood in good condition. Sato *et al.* is directed at improving the storage life of the stored blood by maintaining a partial pressure of carbon dioxide gas in the blood at a low level. Such partial pressure is apparently obtained through normalization with the outside atmosphere. The container is made of a synthetic resin film which has a high permeability to carbon dioxide gas for the purpose of making it possible for the carbon dioxide gas to easily diffuse from the blood to outside. However, the problems caused by the interaction of the oxygen and hemoglobin in the blood are not addressed.

[0012] Another patent, U.S. Patent No. 5,529,821 to Ishikawa *et al.* relates to a container and a method for the storage of blood to prevent adhesion of the blood to the container. Blood is stored in containers composed of a sheet material having a plurality of layers where a first sheet which contacts the blood substantially prevents the activation and adhesion of blood platelets to the layer. Again, however, the problems caused by the interaction of the oxygen and hemoglobin in the blood are not addressed.

[0013] In light of current technology, there is a need to improve the quality of red blood cells that are to be stored and to extend the storage life of such red blood cells in advance of transfusion to minimize morbidity associated with transfusions.

SUMMARY OF THE INVENTION

[0014] The present disclosure includes and provides a depletion device for removing a gas from a liquid including an enclosure having one or more liquid chambers, one or more depletion chambers, at least one gas permeable barrier separating the one or more liquid chambers from the one or more depletion chambers, at least one liquid inlet and at least one liquid outlet.

[0015] The present disclosure includes and provides a gas addition device including an enclosure, one or more liquid chambers, one or more gas addition chambers, at least one gas permeable barrier separating at least one of the liquid chambers from a gas addition chamber, at least one liquid inlet and at least one liquid outlet.

[0016] The present disclosure further includes and provides for a method of preparing a blood product for transfusion including flowing a blood product liquid through a depletion device to prepare a blood product having a increased level of gas.

[0017] Additionally, the present disclosure includes and provides a method for extended storage of red blood cells including obtaining whole blood, passing the whole blood through a depletion device to prepare a depleted blood product, storing the depleted blood product in a gas impermeable storage bag for a period of time to prepare a stored depleted blood product, and passing the stored depleted blood product through a gas addition device to prepare a transfusion blood product.

[0018] In embodiments according to the present disclosure, the method for extended storage of red blood cells may further include editing the transfusion blood product, irradiating the transfusion blood product, performing a buffer exchange of the transfusion blood product, collecting the gas restored blood product in a transfusion bag and combinations thereof.

[0019] The present disclosure also includes and provides for a system for extended storage of red blood cells including a phlebotomy needle, a blood collection bag, an additive solution, a depletion device, a device for leukocyte reduction, a device for editing red blood cells, a device for inactivating pathogens, a device for reducing the volume of a blood product, a device for exchanging the buffer of a blood product, a gas impermeable storage bag for storing a blood product, a device for adding a gas to the stored blood product prior to transfusion, and tubing connecting the devices, the collection bag, and the storage bag.

BRIEF DESCRIPTION OF THE DRAWINGS

[0020] Figures 1A-D illustrate an exemplary single liquid chamber depletion device according to the present disclosure.

5 [0021] Figures 2A-F illustrate exemplary flow control features according to the present disclosure.

[0022] Figures 3A-C illustrate an exemplary depletion device having more than one liquid chamber according to the present disclosure.

[0023] Figures 4A-C illustrate an exemplary single liquid chamber depletion device with a rigid internal liquid chamber and flexible external enclosure.

10 [0024] Figures 5A-C illustrate an exemplary single liquid chamber depletion device having a flexible enclosure, flexible liquid chamber, and a flexible depletion chamber according to the present disclosure.

[0025] Figures 6A-C illustrate an exemplary single liquid chamber depletion device having a flexible enclosure, a flexible liquid chamber with an indirect liquid path, and two
15 flexible depletion chambers.

[0026] Figures 7A-C illustrate an exemplary multi chamber depletion device having a flexible enclosure, two flexible liquid chambers, and three flexible depletion chambers according to the present disclosure.

20 [0027] Figures 8A-C illustrate an exemplary single chamber depletion device having a single liquid chamber and two gas depletion chambers according to the present disclosure.

[0028] Figures 9A-C illustrate an exemplary multi chamber depletion device having two liquid chambers in a series configuration and three gas depletion chambers according to the present disclosure.

25 [0029] Figures 10A-C illustrate an exemplary multi chamber depletion device having two liquid chambers in a parallel configuration and three gas depletion chambers according to the present disclosure.

[0030] Figures 11A-C illustrate exemplary gas flow control features according to the present disclosure.

30 [0031] Figures 12A-C illustrate an exemplary single chamber depletion and plasma separation device having a single liquid chamber, single depletion chamber and a single plasma chamber according to the present disclosure.

[0032] Figures 13A-C illustrate an exemplary depletion and plasma separation device having a single liquid chamber, two depletion chambers and a plasma chamber according to the present disclosure.

5 [0033] Figures 14A-C illustrate an exemplary depletion device having a leukoreduction filter, two depletion chambers and a fluid chamber according to the present disclosure.

[0034] Figures 15A-C illustrate an exemplary depletion device having a leukoreduction filter, a plasma separation chamber, two depletion chambers and a fluid chamber according to the present disclosure.

10 [0035] Figures 16A-C illustrate an exemplary re-oxygenation device having a single fluid chamber and two oxygenation chambers according to the present disclosure.

[0036] Figure 17 illustrates an exemplary flowchart of the components and methodology from blood collection to transfusion using a depletion device of the present disclosure in an anaerobic blood storage system.

15 [0037] Figure 18 illustrates an exemplary system according to Figure 17 of the present disclosure.

DETAILED DESCRIPTION OF THE INVENTION

[0038] The transfusion of red blood cells (RBCs) is a life-saving therapy aimed at improving oxygenation of the tissues and vital end organs in patients. A majority of RBC units used for transfusion are stored at 1-6°C for up to 42 days in an oxygen-permeable
20 polyvinylchloride blood bag that contains additive/preservative solution.

[0039] Blood Donor: Whole blood is preferably donated from a healthy individual or donor and held in a blood bank for later use to be ultimately used by a recipient. Subjects who are scheduled for surgery or other treatment may donate blood for themselves in a process known as autologous blood donation. Alternatively, blood is donated for use by another in a
25 process known as heterologous transfusion. The collection of a whole blood sample drawn from a donor, or in the case of an autologous transfusion from a patient, may be accomplished by techniques known in the art, such as through donation or apheresis.

[0040] Whole Blood: Whole blood is a suspension of blood cells that contains red blood cells, white blood cells, platelets suspended in plasma, including electrolytes, hormones,
30 vitamins, and antibodies.

[0041] Blood products: As used herein, “blood product” or “blood products” refers to, and includes, whole blood, red blood cells, plasma, leukocytes, and platelets. “Blood product” also refers to depleted blood products including packed red blood cells, leukocyte reduced red blood cells, platelet reduced red blood cells. Blood products further include blood products
5 having one or more additive solutions including, but not limited to, anticoagulants, antioxidants, storage additives, and buffers. Depleted blood products, as used herein, refer to blood products depleted of O₂, CO₂ or both, particularly after treatment with, or passage through a device of the present disclosure. Reoxygenated blood products are depleted blood products that have had oxygen levels restored to *in vivo* levels, or higher, usually in preparation for transfusion.

10 [0042] Red Blood Cells (RBCs): As used herein, “red blood cells” (RBCs), “packed red blood cells” (pRBCs), and “red blood cell suspensions” refer to and include blood products having red blood cells or erythrocytes. Red blood cells further include red blood cell products having one or more additive solutions. Red blood cells as used herein, may be depleted or reduced of leukocytes and other non-erythrocytes. As used herein, red blood cells include
15 compositions depleted of plasma (plasma reduced). Red blood cells, as used herein, may further include red blood cell products having reduced or depleted platelets.

[0043] White blood cells: White blood cells or leukocytes as used herein include granulocytes also known as polymorphonuclear leukocytes. Granulocytes include neutrophils, basophils, and eosinophils. White blood cells also include agranulocytes, also known as
20 mononuclear leukocytes, and include monocytes, and macrophages. Blood products according to the present disclosure include leukoreduced and leukodepleted blood.

[0044] Platelets: Platelets are small cellular components of blood that facilitate the clotting process by sticking to the lining of the blood vessels. The platelets like the red blood cells are made by the bone marrow and survive in the circulatory system for 9 to 10 days before
25 they are removed by the spleen. Platelets are typically prepared using a centrifuge to separate the platelets from the plasma. Platelets, unlike RBCs, require O₂ for the generation of ATP.

[0045] Plasma: Plasma is a protein-salt solution and the liquid portion of the blood in which red and white blood cells and platelets are suspended. Plasma is 90% water and constitutes about 55 percent of the blood volume. One of the primary functions of plasma is to
30 assist in blood clotting and immunity. Plasma is obtained by separating the liquid portion of the blood from the cells. Typically, plasma is separated from the cells by centrifugation.

Centrifugation is the process used to separate the components of the whole blood into the plasma, the white blood cells, the platelets and the packed red blood cells. During centrifugation, the plasma will initially migrate to the top of a vessel during a light spin. The plasma is then removed from the vessel. The white blood cells and platelets are removed during
5 a second centrifugation cycle to produce the packed red blood cells.

[0046] As used herein and in the appended claims, the singular forms “a,” “an,” and “the” include plural references unless the content clearly dictates otherwise. Thus, for example, reference to “a sorbent” includes a plurality of such sorbents and equivalents thereof known to those skilled in the art, and so forth, and reference to “the sorbent” is a reference to one or more
10 such sorbents and equivalents thereof known to those skilled in the art, and so forth.

[0047] Human red blood cells *in vivo* are in a dynamic state. In whole blood, white blood cells are normally present in the range between 4,300 and 10,800 cells/ μ L and the normal RBC range at sea level is 5.4 million/ μ L (+ 0.8) for men and 4.8 million μ L (+ 0.6) for women. The red blood cells contain hemoglobin, the iron-containing protein that carries oxygen
15 throughout the body and gives red blood its color. The percentage of blood volume composed of red blood cells is called the hematocrit. Packed red blood cells are prepared from whole blood using centrifugation techniques commonly known in the art. The packed red blood cells are the blood component that will be stored in the unique storage system of this invention for later transfusion.

[0048] The normal life span of a red blood cell (RBC) is 120 days. Approximately 0.875% of the RBCs are retired every 24 hours by the spleen and new RBCs are made by the bone marrow. Consequently, when blood is drawn from a donor, there are a percentage of white blood cells and a spectrum of cells of different ages.

[0049] The main function of RBCs is to exchange oxygen and carbon dioxide at lung and
25 tissues, and unlike other cells in body, it does not rely on oxygen in oxidative phosphorylation but entirely on glycolysis for ATP production. ATP is critical for viability of RBCs and, together with 2,3-DPG, their free cytosolic concentrations are tightly regulated by their function on feedback inhibition to key enzymes in glycolytic pathway. Under refrigerated storage condition, dis-inhibition of glycolytic pathway is desirable to overcome the gradual depletion of
30 ATP and 2,3-DPG over several weeks of storage. Hemoglobin concentration in RBCs is similar to 2,3-DPG and ATP, and its deoxygenated state has a binding pocket with high affinities for

2,3-DPG and ATP compared to oxy-hemoglobin. Thus, stripping this oxygen to few % occupancy (~60% occupied when collected and processed) will cause uptake of 2,3-DPG and ATP, resulting in reduced concentration of free molecules, stimulating glycolytic flux. In a healthy individual, the percent saturation of hemoglobin in RBCs (sO_2) in the lungs is 100%. As the RBCs circulate through the body, O_2 is released and the sO_2 can reach less than 10% sO_2 in hypoxic tissues.

[0050] As used herein, a liquid may be provided to a device of the present disclosure either by gravity flow or by a pump, including but not limited to a peristaltic pump. The flow rate may be controlled by adjusting the head height in the case of a gravity driven flow, change in pump velocity or by restricting the flow. It is understood that blood products, particularly cellular components of blood products may be damaged by high pressures or high velocity liquid flows. Accordingly, flows are controlled to minimize or eliminate cellular damage. In an aspect, the pressure drop of a liquid flowing through the device should not exceed 2 lbs/in². In another aspect, the pressure drop of a liquid flowing through the device should not exceed 1.5 lbs/in². In another aspect, the pressure drop of a liquid flowing through the device should not exceed 1.0 lbs/in².

[0051] The present disclosure provides for and includes a depletion device for removing a gas from a liquid comprising an enclosure. In certain embodiments according to the present disclosure, the enclosure may be a rigid enclosure as shown for example in Figures 1A-D, 2A-C, 5A-C, and 6A-C. Referring to Figures 1A-C, a rigid enclosure according to the present disclosure may be prepared from an outer shell **103** and may include inner shell **109** which may further incorporate flow control features **108**. In certain embodiments, two outer shells **103** and inner shell **109** may be joined using any suitable manner known in the art including adhesive and bonding materials, *e.g.*, glues, epoxies, bonding agents, and adhesives such as loctite 409 or other suitable super glue, welding and bonding processing, *e.g.*, ultrasonic or thermosonic bonding, thermal bonding, diffusion bonding, or press-fit, etc.

[0052] Referring to Figures 3A-C, a rigid enclosure may include two outer shells **103**, one or more inner shells **109** and one or more enclosure shells **110** to form two or more liquid chambers **101** and two or more depletion chambers **102** where liquid chambers **101** and depletion chambers **102** are separated from, and formed by gas permeable barriers **107**. In certain embodiments, liquid chambers **101** and depletion chambers **102** may be separated from, and

formed by gas impermeable to prepare divided and isolated liquid chambers **101** and depletion chambers **102**. Enclosures comprising two outer shells **103**, one or more inner shells **109**, gas permeable barriers **107** and one or more gas impermeable barriers may be joined in any known manner as provided above including adhesives, glues, epoxies, bonding agents, welding,
5 ultrasonic or thermosonic bonding, or thermal bonding.

[**0053**] In another embodiment, the enclosure may be a flexible material divided into one or more liquid chambers, one or more depletion chambers, and combinations thereof. In some embodiments, the enclosure may be a flexible bag enclosing one or more liquid chambers or one or more depletion chambers that are rigid, and combinations thereof. In some embodiments
10 according to the present disclosure, an enclosure may be gas impermeable, gas permeable, or gas permeable and coated with a gas impermeable barrier or film. In other embodiments, the flexible material may be formed into a bag. In some embodiments, the flexible material may also be elastic.

[**0054**] According to the present disclosure, a flexible enclosure may be an enclosure that
15 is capable of being bent or flexed. A flexible enclosure may be pliant, pliable, flexile, or elastic. A flexible enclosure may expand either through a change in shape due to flexibility or through an elastic expansion to contain a total volume. A flexible enclosure expands and contains a volume under ambient pressure. An elastic enclosure expands when the internal pressure of the enclosure is greater than the ambient pressure. According to the present disclosure, the ambient
20 pressure corresponds to atmospheric pressure (typically 760 Torr) without consideration to changes in pressure due to weather or altitude.

[**0055**] The volume of a flexible enclosure may be described by the following equation

$$V_t = V_v + V_l + V_d + V_c$$

where V_t is the total expanded volume, whether by elastic or inelastic expansion, V_v is the initial
25 volume comprising a void volume, V_l is the volume of liquid contained in one or more liquid chambers, V_d is the volume contained in one or more gas depletion chambers **115** or depletion chamber **102** when the depletion device is fully expanded, and V_c is the volume of the internal components of the bags including the unfilled gas depletion chambers **115** and unfilled liquid chambers **101**. V_c includes the volume of any depletion media **106** contained in a depletion
30 device. An unused, unexpanded flexible bag of the current disclosure would have an initial volume $V_i = V_v + V_c$.

[0056] In an embodiment of the present disclosure, V_1 equals the volume of a standard unit of blood. In another embodiment, V_1 equals about 500 mls. In a further embodiment, V_1 does not exceed 600 ml. In another embodiment, V_1 may be between 100 and 550 ml. In a further embodiment the volume V_1 may be 300 to 500 ml or 300 to 550 ml.

5 [0057] In embodiments according to the present disclosure, the flexible enclosure further includes features to prevent the plastic from sticking together. In an embodiment, the feature may be textured to prevent the plastic from sticking together. In embodiments according to the present disclosure, a texture may be ridges, bumps, threads, strands or other features to make the surface of the enclosure rough. In an embodiment, the textured surface may be on the inside of
10 the enclosure. In an embodiment, the textured surface contacts the liquid.

[0058] In certain embodiments, an flexible enclosure may enclose an initial volume (V_v) corresponding to the unexpanded enclosure volume which may also be termed a dead or void volume. A void volume V_v may be minimized by applying a vacuum to remove any air present during manufacture to provide a decreased initial volume V_i . In other embodiments, the air
15 present during manufacture may be flushed with a flushing gas before applying a vacuum to minimize V_v . In some embodiments, a flushing gas may be used to replace the air present during the manufacturing process. Several gases suitable for a flushing gas include, but are not limited to, argon, helium, and nitrogen. A flushing gas may be used to decrease the amounts of oxygen, carbon dioxide, or both in the depletion device. In an embodiment, the flushing gas has a partial
20 pressure of oxygen of less than 1 Torr. In another embodiment, the flushing gas has a partial pressure of oxygen and carbon dioxide of less than 1 Torr.

[0059] In embodiments according to the present disclosure, a volume contained by a flexible depletion device may increase to a total volume (V_t) as a liquid for depletion is provided through at least one liquid inlet **104**. A flexible depletion device containing a liquid will have a
25 liquid volume V_l . In some embodiments, the liquid volume may displace any air or flushing gas present so that $V_v = 0$. In some embodiments, the total volume (V_t) may include a volume corresponding to the volume of a depletion gas (V_d) provided through at least one gas inlet **111**. In embodiments of a depletion device having a depletion media **106**, V_d will be near zero as the volume of the depletion media is included in V_c . In another embodiment, the volume of the
30 depletion media will be less than 50 cm^3 .

[0060] According the present disclosure, a flexible enclosure may be able to adjust in volume as a liquid or a gas is provided through at least one gas inlet **111**. Liquid or gas that does not immediately exit through at least one liquid outlet **105** or at least one gas outlet **112** may accumulate in a flexible enclosure causing an increase in contained volume of a flexible enclosure by V_d . In embodiments according the present disclosure, the flow rate of a gas through gas inlet **111** and gas outlet **112** is less than 20 liters per hour. In other embodiments, the maximum gas flow rate is less than 18 liters per hour. In yet another embodiment, the flow rate is less than 15 liters per hour. In further embodiments, the flow rate of a gas through gas inlet **111** and gas outlet **112** is less than 10 liters per hour or less than 5 liters per hour.

[0061] Referring to Figures 4A-C, a depletion device **400** according to the present disclosure may be prepared from both flexible and rigid materials. In an embodiment, the enclosure of a depletion device may be prepared from a flexible shell **129** and a rigid inner shell **109** having flow control features **108**. Flexible shell **129** may be prepared from a gas impermeable material or coated with a gas impermeable material. In certain embodiments, flexible shell **129** may also be expandable. In some embodiments, a flexible shell **129** may be expandable and elastic. In other embodiments, flexible shell **129** may be a laminated material that is gas impermeable. In certain embodiments, the combination of flexible shell **129** and one or more inner shells **109** provide for a gas impermeable enclosure. In certain embodiments, an enclosure may have a flexible shell **129** combined with a outer shell **103** and one or more inner shells **109**.

[0062] As illustrated in Figures 5A-C, 6A-C, and 7A-C, enclosures according the present disclosure may be prepared as a flexible or expandable enclosure. Referring to Figures 5A-C, the enclosure of device **500** may formed of two gas barrier film flexible shells **129** separated from an inner liquid chamber by two gas permeable barriers **107** to prepare a single liquid chamber **101**.

[0063] Referring to Figures 6A-C, a device **600** may include a flexible shell **129** housing a liquid chamber **101** formed from two gas permeable barriers **107**. As illustrated in Figures 6A-C, the two gas permeable barriers **107** may be joined together to prepare a liquid chamber **101** having an indirect path **133**. As shown in exemplary device **600**, the liquid chamber **101** may have a zig-zag path for liquid flow to provide for mixing, thickness control, and flow control. In other embodiments, liquid path **133** of liquid chamber **101** may be bifurcated and rejoined one or

more times. In some embodiments, liquid path **133** may be divided into three or more paths that are rejoined prior to liquid outlet **105**. In some embodiments, liquid path **133** may be divided into four or more paths that are rejoined prior to liquid outlet **105**. In some embodiments, liquid path **133** may be divided into five or more paths that are rejoined prior to liquid outlet **105**. In other embodiments, liquid path **133** may have 6, 7, 8, 9, 10, or more branches that rejoin prior to liquid outlet **105**. The liquid path **133** of device **600** may increase the path length traveled by the liquid and may increase the residence time of the fluid flowing in liquid chamber **101**. A liquid path **133** may provide for increased mixing of the liquid and increase the exposure of the liquid to the gas permeable barrier **107** and an adjacent depletion chamber **102**. Depletion chambers **102** may include depletion media **106**.

[0064] In an embodiment, liquid path **133** may have a cross-sectional shape selected from the group consisting of rectangular, circular, and irregular shape. In certain embodiments, liquid path **133** may have more than one cross-sectional shape along its longitudinal path, selected from one or more of the group consisting of rectangular, circular, and irregular shape. In an embodiment, liquid path **133** may have a uniform cross-sectional area along its longitudinal path. In certain embodiments, liquid path **133** may have a changing cross-sectional area along its longitudinal path.

[0065] In some embodiments, a rectangular cross-section of liquid path **133** may have a depth of 0.01 mm or more. In an embodiment, a rectangular cross-section of liquid path **133** may have a depth of 0.1 mm or more. In an embodiment, a rectangular cross-section of liquid path **133** may have a depth of 0.2 mm or more. In an embodiment, a rectangular cross-section of liquid path **133** may have a depth of 0.3 mm or more. In an embodiment, a rectangular cross-section of liquid path **133** may have a depth of 0.4 mm or more. In an embodiment, a rectangular cross-section of liquid path **133** may have a depth of 0.5 mm or more. In other embodiments, a rectangular cross-section of liquid path **133** may have a depth of up to 0.6 mm. In another embodiment, a rectangular cross-section of liquid path **133** may have a depth of up to 0.7 mm. In yet other embodiments, a rectangular cross-section of liquid path **133** may have a depth of up to 0.8 mm, 0.9 mm, or 1.0 mm. In other embodiments, a rectangular cross-section of liquid path **133** may have a depth of between 1.0 and 2.0 mm. In other embodiments, a rectangular cross-section of liquid path **133** may have a depth of between 1.5 and 2.0 mm. In other embodiments, a rectangular cross-section of liquid path **133** may have a depth of between 1.75 and 2.0 mm. In

certain other embodiments, a rectangular cross-section of liquid path **133** may have a depth of between 2.0 mm and 3.0 mm. In certain embodiments, a rectangular cross-section of liquid path **133** may have a depth of between 2.5 mm and 3.0 mm. In some embodiments, the rectangular cross-section of liquid path **133** may vary and have one or more depths.

5 **[0066]** In some embodiments, liquid path **133** may be a micro channel. In some embodiments, a circular cross-section of liquid path **133** may have a diameter of between 100 μm and 500 μm . In some embodiments a circular cross-section of liquid path **133** may have a diameter of 100 μm or more. In some embodiments a circular cross-section of liquid path **133** may have a diameter of 150 μm , or more. In some embodiments a circular cross-section of
10 liquid path **133** may have a diameter of 200 μm . In some embodiments a circular cross-section of liquid path **133** may have a diameter of 250 μm . In some embodiments a circular cross-section of liquid path **133** may have a diameter of 300 μm . In some embodiments a circular cross-section of liquid path **133** may have a diameter of 350 μm . In some embodiments a circular cross-section of liquid path **133** may have a diameter of 400 μm . In yet other
15 embodiments a circular cross-section of liquid path **133** may have a diameter of 450 μm or 500 μm .

[0067] In some embodiments, an irregular cross-section of liquid path **133** may have an area in the range of 0.01 to 10 mm^2 . In an embodiment, an irregular cross-section of liquid path **133** may have an area in the range of 0.01 to 0.1 mm^2 . In an embodiment, an irregular cross-
20 section of liquid path **133** may have an area in the range of 0.1 to 1 mm^2 . In an embodiment, an irregular cross-section of liquid path **133** may have an area in the range of 1 to 5 mm^2 . In an embodiment, an irregular cross-section of liquid path **133** may have an area in the range of 5 to 10 mm^2 .

[0068] According to the present disclosure, liquid path **133** may have longitudinal paths
25 selected from the group consisting of meandering, sinuous, undulating, sinusoidal, spiral, partially spiral, and zig-zag. In an embodiment, the path length of a liquid path **133** may be at least 10 fold or more of the length of flexible shell **129**. In another embodiment, the path length of a liquid path **133** may be at least 15 fold or more of the length of flexible shell **129**. In another embodiment, the path length of a liquid path **133** may be at least 20 fold or more of the length of
30 flexible shell **129**. In another embodiment, the path length of a liquid path **133** may be at least 30 fold or more of the length of flexible shell **129**. In another embodiment, the path length of a

liquid path **133** may be at least 40 fold or more of the length of flexible shell **129**. In another embodiment, the path length of a liquid path **133** may be at least 50 fold or more of the length of flexible shell **129**.

[0069] Referring to Figures 7A-C, a flexible or expandable enclosure may be formed of two flexible shells **129** separated from and inner liquid chamber by two gas permeable barriers **107** and further divided into chambers by additional gas permeable barriers **107**. As illustrated in Figure 7B, two flexible shells **129** separated by four gas permeable barriers **107** may result in two liquid chambers **101** and three depletion chambers **102**. In certain embodiments according to the present disclosure, the addition of a further gas permeable barrier **107** results in the formation of one added liquid chamber **101** and one added depletion chamber **102**. According to the present disclosure, a depletion device may include three depletion chambers and two liquid chambers. In an embodiment, a depletion device may include four depletion chambers and three liquid chambers. In an embodiment, a depletion device may include five depletion chambers and four liquid chambers. In other embodiments, a depletion device may include six depletion chambers and five liquid chambers.

[0070] In embodiments according to the present disclosure, a flexible shell **129** (e.g., a flexible shell **129**, which can also be expandable), may be prepared from a gas impermeable plastic. In an embodiment, the gas impermeable plastic may be a laminate. In certain embodiments, the laminate may be a transparent barrier film, for example a nylon polymer. In an embodiment, the laminate may be a polyester film. In an embodiment, the laminate may be Mylar®. In certain embodiments, the laminate may be a metalized film. In an embodiment, the metalized film may be coated with aluminum. In another embodiment, the coating may be aluminum oxide.

[0071] Flexible shell **129** according to the present disclosure may be joined in any known manner including fixing by adhesive or otherwise bonding using any suitable manner known in the art including adhesive and bonding materials, e.g., glues, epoxies, bonding agents, and adhesives such as loctite **409** or other suitable super glue, welding and bonding processing, e.g., ultrasonic or thermosonic bonding, thermal bonding, diffusion bonding, or press-fit, etc.

[0072] In certain embodiments, an enclosure may have both flexible and rigid aspects where the flexible aspect provides for expansion to accommodate the liquid flowing through one or more chambers. In some embodiments, an enclosure may include a combination of rigid outer

shells **103**, flexible shells **129**, inner shells **109**, enclosure shells **110**, and gas permeable barriers **107** thereby providing a bag or container that expands as a liquid flows through the enclosure, liquid chambers and depletion chambers.

[0073] An enclosure according the present disclosure may be formed of one or more parts prepared from a gas impermeable material including a plastic or other durable lightweight material. In some embodiments, an enclosure may be formed of more than one material. In an embodiment, an enclosure may be formed of a material and coated with a gas impermeable material to prepare a gas impermeable enclosure. In an embodiment, a rigid or flexible enclosure may be prepared from a plastic that may be injection molded. In embodiments according the instant disclosure, the plastic may be selected from polystyrene, polyvinyl chloride, or nylon. In an embodiment, enclosure materials may be selected from the group consisting of polyester (PES), polyethylene terephthalate (PET), polyethylene (PE), high-density polyethylene (HDPE), polyvinyl chloride (PVC), polyvinylidene chloride (PVDC), low-density polyethylene (LDPE), polypropylene (PP), polystyrene (PS), high impact polystyrene (HIPS), polyamides (PA) (*e.g.*, nylon), acrylonitrile butadiene styrene (ABS), polycarbonate (PC), polycarbonate/acrylonitrile butadiene styrene (PC/ABS), polyurethanes (PU), melamine formaldehyde (MF), plastarch material, phenolics (PF), polyetheretherketone (PEEK), polyetherimide (PEI) (Ultem), polylactic acid (PLA), polymethyl methacrylate (PMMA), polytetrafluoroethylene (PTFE), and urea-formaldehyde. In certain embodiments, the enclosure may be polyethylene. In some embodiments, the polyethylene enclosure may comprise one or more polyethylene components that are welded together.

[0074] The present disclosure further provides for and includes a depletion device having one or more liquid chambers or cavities. In some embodiments, a liquid chamber may be a rigid chamber or cavity as provided above. In other embodiments, a liquid chamber may be a flexible chamber or cavity as provided above. In an embodiment, one or more liquid chambers may be a chamber, cavity or space through which a liquid flowing through the depletion device may flow. In embodiments according the present disclosure, one or more liquid chambers may be in liquid communication with each other and in liquid communication with at least one liquid inlet and at least one liquid outlet.

[0075] As illustrated in Figures 1A-D, a rigid liquid chamber **101** may be formed by a combination of an inner shell **109** and two gas permeable barriers **107**. Similarly, as illustrated

in Figures 3A-C, 9A-C and 10A-C, embodiments of depletion devices of the present disclosure may have two or more rigid liquid chambers **101** formed by a combination of two or more outer inner shells **109** each combined with two gas permeable barriers **107**. In other embodiments, for example as illustrated in Figures 5A-C, 6A-C, and 7A-C, a liquid chamber **101** may be formed
5 by a combination of two flexible gas permeable barriers **107**. In certain embodiments according to the present disclosure, the outer enclosure is 5 inches x 8 inches. In certain embodiments, the gas permeable barrier is between 35 to 175 μm thick.

[**0076**] In certain embodiments according to the present disclosure, a liquid chamber **101** may further comprise flow control features **108** as provided below to direct the flow of liquid and
10 provide for mixing of a liquid flowing through the liquid chambers by, for example, disrupting laminar flow of the liquid. In other embodiments, a liquid chamber **101** may include flow control features that provide for an indirect path **133**. Though not limited by theory, mixing of the liquid in the liquid chambers may ensure efficient diffusion and depletion of oxygen and carbon dioxide gases to the depletion chambers.

[**0077**] Similarly, in certain embodiments including a flexible enclosure, in whole or in
15 part, gas permeable barriers **107** forming liquid chamber **101** may further include flow control features to direct the flow of liquid and to provide for mixing by, for example, disrupting laminar flow of the liquid. As illustrated in Figures 5A-C and 7A-C, liquid chamber **101** is depicted without flow control features. As illustrated in Figure 6A-C, liquid chamber **101** includes an
20 indirect path **133** that provides flow control features. Flow control features may be formed, for example, by bonding the gas permeable barriers **107** together in a manner that would direct the flow of blood along a controlled path or indirect path **133**, in the gas permeable barriers **107**. This directed flow would both mix and minimize the distance between individual red cells and the gas permeable barriers **107**. The number and position of flow control features may also be
25 altered to optimize the process for specific configuration. In an embodiment according to the present disclosure, gas permeable barriers **107** may include ridges that are oriented perpendicular to the flow of the liquid. In other embodiments, gas permeable barriers **107** may include ridges oriented at an angle relative to the flow of liquid. Flow control features according to the present enclosure are provided in greater detail below.

[**0078**] As illustrated in Figures 12A-C and 13A-C, a liquid chamber **101** may provide for
30 the depletion of plasma from a liquid flowing in the liquid chamber **101**. As illustrated in

Figures 12A-C, one of the gas permeable barriers **107** may be replaced with a plasma porous hydrophilic membrane **124** which is capable of retaining red blood cells and allowing for the passage of anaerobic plasma through the hydrophilic membrane **124** and into plasma chamber **117**. Anaerobic plasma may then flow from plasma chamber **117** out through anaerobic plasma port **116**. As illustrated in Figures 13A-C, a second depletion chamber **122** may be included in a combined plasma and gas depletion device. As shown in Figures 13A-C, depletion chamber **122** is separated from plasma chamber **117** by a gas permeable barrier **107**. Additional configurations of gas permeable barriers **107**, plasma porous hydrophilic membrane **124**, plasma outer shell **119**, outer shell **103**, and other described components can provide for additional depletion chambers **102** or **122**, additional plasma chambers **117**, and additional liquid chambers **101**. It should be understood that such additional chambers may be arranged in series or parallel with the appropriate connections.

[0079] In accordance with the present disclosure, the surfaces of a liquid chamber **101** in contact with the liquid can be a biocompatible material. Similarly, other surfaces and components of the gas depletion device in liquid communication with the liquid are prepared from biocompatible materials. In an embodiment, a biocompatible material is a compatible blood product of the present disclosure. Biocompatible materials of the present disclosure include those defined and provided in International Standard ISO 10993.

[0080] The present disclosure further provides for and includes depletion devices having one or more depletion chambers or cavities. In certain embodiments according to the present disclosure, depletion chamber **102** has lower concentrations or partial pressures of a gas than the concentration or partial pressure of a gas present in liquid chamber **101** separated from the depletion chamber **102** by a gas permeable barrier **107**. Accordingly, a gas flows from a liquid chamber **101** having a higher concentration to a depletion chamber **102**, thus depleting the liquid in liquid chamber **101** of a gas. In certain embodiments, a depletion device may have two depletion chambers. In some embodiments, a depletion device may have three depletion chambers. In other embodiments, a depletion device may have four depletion chambers. In further embodiments, a depletion device may have five or six depletion chambers. In yet further embodiments, a depletion device may have seven, eight or more depletion chambers.

[0081] In embodiments according to the present disclosure, a depletion device may have from two to five, two to seven, two to nine, or two to eleven depletion chambers. In other

embodiments, a depletion device may have from three to six, three to eight, three to ten, or three to twelve depletion chambers. In other embodiments, the number of depletion chambers may be up to 10, up to 12, up to 14, up to 16, or more than 16 depletion chambers.

[0082] In embodiments according to the present disclosure, a gas having a lower concentration or partial pressure in depletion chamber **102** than in liquid chamber **101** may be oxygen. Depletion chamber **102** having a lower concentration or partial pressure of oxygen is an oxygen depletion chamber **102**. In certain embodiments, an oxygen depletion chamber **102** may contain little or no oxygen. In another embodiment, an oxygen depletion chamber **102** may have a partial pressure of oxygen of less than 1 mmHg (less than 1 Torr) prior to use as a depletion device. In another embodiment, an oxygen depletion chamber **102** may have a partial pressure of oxygen of less than 0.1 mmHg prior to use as a depletion device. In a further embodiment, an oxygen depletion chamber **102** may have a partial pressure of oxygen of less than 0.05 mmHg prior to use as a depletion device. In yet another embodiment, an oxygen depletion chamber **102** may have a partial pressure of oxygen of less than 0.08 mmHg prior to use as a depletion device. In embodiments according to the present disclosure, an oxygen depletion chamber **102** may have a partial pressure of oxygen of between 0.01 mmHg and 0.1 mmHg prior to use as a depletion device. In an embodiment, an oxygen depletion chamber **102** may have a partial pressure of oxygen of between 0.05 mmHg and 0.5 mmHg prior to use as a depletion device.

[0083] In embodiments according to the present disclosure, depletion chamber **102** may have a lower concentration or partial pressure of oxygen and carbon dioxide than compared to a liquid in liquid chamber **102**. A depletion chamber **102** having a lower concentration or partial pressure of oxygen and carbon dioxide is an oxygen and carbon dioxide depletion chamber **102**. In certain embodiments, an oxygen and carbon dioxide depletion chamber **102** may contain little or no oxygen and carbon dioxide prior to use as a depletion device. In other embodiments, an oxygen and carbon dioxide depletion chamber **102** may have a partial pressure of oxygen and carbon dioxide of less than 1 mmHg each (less than 1 Torr) prior to use as a depletion device. In another embodiment, an oxygen and carbon dioxide depletion chamber **102** may have a partial pressure of oxygen and carbon dioxide of less than 0.1 mmHg each prior to use as a depletion device. In a further embodiment, an oxygen and carbon dioxide depletion chamber **102** may have a partial pressure of oxygen and carbon dioxide of less than 0.05 mmHg each prior to use as a depletion device. In yet another embodiment, an oxygen and carbon dioxide depletion

chamber **102** may have a partial pressure of oxygen and carbon dioxide of less than 0.08 mmHg each prior to use as a depletion device. In embodiments according to the present disclosure, an oxygen and carbon dioxide depletion chamber **102** may have a partial pressure of oxygen and carbon dioxide of between 0.01 mmHg and 0.1 mmHg each prior to use as a depletion device. In
5 an embodiment, an oxygen and carbon dioxide depletion chamber **102** may have a partial pressure of oxygen and carbon dioxide of between 0.05 mmHg and 0.5 mmHg each prior to use as a depletion device.

[0084] In embodiments according to the present disclosure, a gas having a lower concentration or partial pressure in depletion chamber **102** than in liquid chamber **101** may be
10 carbon dioxide. Depletion chamber **102** having a lower concentration or partial pressure of carbon dioxide is a carbon dioxide depletion chamber **102**. In certain embodiments, a carbon dioxide depletion chamber **102** may contain little or no carbon dioxide. In another embodiment, a carbon dioxide depletion chamber **102** may have a partial pressure of carbon dioxide of less than 1 mmHg (less than 1 Torr) prior to use as a depletion device. In another embodiment, a
15 carbon dioxide depletion chamber **102** may have a partial pressure of carbon dioxide of less than 0.1 mmHg prior to use as a depletion device. In a further embodiment, a carbon dioxide depletion chamber **102** may have a partial pressure of carbon dioxide of less than 0.05 mmHg prior to use as a depletion device. In yet another embodiment, a carbon dioxide depletion chamber **102** may have a partial pressure of carbon dioxide of less than 0.08 mmHg prior to use
20 as a depletion device. In embodiments according to the present disclosure, a carbon dioxide depletion chamber **102** may have a partial pressure of carbon dioxide of between 0.01 mmHg and 0.1 mmHg prior to use as a depletion device. In an embodiment, a carbon dioxide depletion chamber **102** may have a partial pressure of carbon dioxide of between 0.05 mmHg and 0.5 mmHg prior to use as a depletion device.

[0085] In embodiments according to the present disclosure, a lower concentration or partial pressure of a gas of depletion chamber **102** may be achieved by providing a depletion media **106**. In an embodiment, a depletion media **106** may be an oxygen sorbent material. In another embodiment, a depletion media **106** may be a carbon dioxide sorbent material. In yet another embodiment, a depletion media **106** may be a combined oxygen and carbon dioxide
30 sorbent material.

[0086] A depletion media **106** may be an oxygen sorbent material and an oxygen depletion media **106** is a depletion media **106** having an oxygen sorbent material. As used herein, “oxygen sorbent” is a material that irreversibly binds to or combines with oxygen under the conditions of use. As used herein, “oxygen sorbent” is a material capable of binding to, or combining with, oxygen irreversibly under the conditions of use. The term “oxygen scavenger” may be used interchangeably herein with “oxygen sorbent.” In certain embodiments according to the present disclosure, a material may bind to or combine with oxygen irreversibly. In embodiments according to the present disclosure, a material binds oxygen with higher affinity than hemoglobin. In embodiments according to the present disclosure, O₂ depletion media may be materials that remove oxygen from RBCs or strip oxygen from the blood prior to storage. An oxygen scavenger can be used to remove the oxygen from the RBCs prior to storage in a blood bag. In other embodiments, oxygen may bind to a sorbent material and have a very slow rate of release, k_{off} . In an embodiment, the oxygen may chemically react with some component of the material and be converted into another compound. Any material where the off-rate of bound oxygen is less than the residence time of the blood can serve as an oxygen scavenger. In certain embodiments, a depletion media **106** may be an oxygen sorbent material that can deplete a unit of blood to less than 3% sO₂ in thirty minutes. A depletion media **106**, of an oxygen sorbent material that can deplete 34 ml of blood to 3% sO₂ in two minutes. Oxygen sorbent materials may be formed into or incorporated in fibers, microspheres, gels and foams.

[0087] In embodiments according to the present disclosure, an oxygen depletion media **106** may be a mixture of non-toxic inorganic and/or organic salts and ferrous iron or other materials with high reactivity toward oxygen. In certain embodiments, an oxygen depletion media **106** may be made from particles that have significant absorbing capacity for O₂ (more than 5 ml O₂/g) and can maintain the inside of a depletion chamber **102** to less than 0.01%, which corresponds to pO₂ less than 0.08 mmHg. An oxygen depletion media **106** may be either free or contained in an oxygen permeable envelope as described below. A gas depletion device according to the present disclosure can deplete approximately 100 mL of oxygen from a unit of blood.

[0088] Examples of oxygen scavengers include iron powders, for example ferrous ion containing powders, and organic compounds. For example, oxygen sorbents are provided by Multisorb Technologies (Buffalo, NY). Such materials can be blended to a desired ratio to

achieve desired results. Non-limiting examples of oxygen scavengers include iron powders and organic compounds. Examples of O₂ sorbents include chelates of cobalt, iron, and Schiff bases. Additional non-limiting examples for O₂ sorbents may be found in Bulow *et al.*, U.S. Patent No. 7,347,887, issued March 25, 2008, entitled “Oxygen sorbent compositions and methods of using same”; Ramprasad *et al.*, U.S. Patent No. 5,208,335, issued May 4, 1993, entitled “Reversible oxygen sorbent compositions”; and Sievers *et al.*, U.S. Patent No. 4,654,053, issued March 31, 1987, entitled “Oxygen Sorbent,” each of which is hereby incorporated by reference in its entirety.

[0089] In embodiments according to the present disclosure, a sorbent may be an oxidizable organic polymer having a polymeric backbone and a plurality of pendant groups. Examples of sorbents with a polymeric backbone include a saturated hydrocarbon (< 0.01% carbon-carbon double bonds). In some embodiments, the backbone can contain monomers of ethylene or styrene. In an embodiment, a polymeric backbone may be ethylenic. In another embodiment, an oxidizable organic compound may be ethylene/vinyl cyclohexene copolymer (EVCH). Additional examples of substituted moieties and catalysts are provided in Yang *et al.*, U.S. Patent Publication No. 2003/0183801, hereby incorporated by reference in its entirety. In additional embodiments, an oxidizable organic polymer can also comprise substituted hydrocarbon moieties. Examples of oxygen scavenging polymers include those described by Ching *et al.*, International Patent Publication W099/48963, hereby incorporated by reference in its entirety. Oxygen scavenging materials may include those provided in Ebner *et al.*, U.S. Patent No. 7,754,798, issued July 13, 2010, entitled “Oxygen scavenger block copolymers and compositions”; Ebner *et al.*, U.S. Patent No. 7,452,601, issued November 18, 2008, entitled “Oxygen scavenger compositions derived from isophthalic acid/or terephthalic acid monomer or derivatives thereof”; Ebner *et al.*, U.S. Patent No. 6,387,461, issued May 14, 2002, entitled “Oxygen scavenger compositions,” each of which is hereby incorporated by reference in its entirety.

[0090] A depletion media **106** may be a carbon dioxide sorbent material and a carbon dioxide depletion media **106** is a depletion media **106** having a carbon dioxide sorbent material. As used herein, “carbon dioxide sorbent” is a material that irreversibly binds to or combines with carbon dioxide under the conditions of use. As used herein, “carbon dioxide sorbent” is a material capable of binding to or combining with carbon dioxide irreversibly under the

conditions of use. The term “carbon dioxide scavenger” may be used interchangeably herein with “carbon dioxide sorbent.” In certain embodiments according to the present disclosure, a material may bind to or combine with carbon dioxide irreversibly. In embodiments according to the present disclosure, a material binds carbon dioxide with higher affinity than hemoglobin. In other embodiments, a sorbent material may bind carbon dioxide with high affinity such that the carbonic acid present in the blood or RBC cytoplasm is released and absorbed by the sorbent.

[0091] In embodiments according to the present disclosure, carbon dioxide depletion media may be materials that remove carbon dioxide from RBCs or strip carbon dioxide from the blood prior to storage. A carbon dioxide scavenger can be used to remove the carbon dioxide from the RBCs prior to storage in a blood bag. In other embodiments, carbon dioxide may bind to a sorbent material and have a very slow rate of release, k_{off} . In an embodiment, the carbon dioxide may chemically react with some component of the material and be converted into another compound. Any material where the off-rate of bound carbon dioxide is less than the residence time of the blood can serve as a carbon dioxide scavenger. In certain embodiments, carbon dioxide depletion media **106** can deplete a unit of blood of carbon dioxide in 2 minutes. Carbon dioxide sorbent materials may be formed into or incorporated in fibers, microspheres, gels and foams.

[0092] Carbon dioxide scavengers include metal oxides and metal hydroxides. Metal oxides react with water to produce metal hydroxides. The metal hydroxide reacts with carbon dioxide to form water and a metal carbonate. In an embodiment, the carbon dioxide scavenger may be calcium oxide. For example, if calcium oxide is used, the calcium oxide will react with water that is added to the sorbent to produce calcium hydroxide.

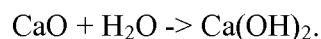

[0093] The calcium hydroxide will react with carbon dioxide to form calcium carbonate and water.

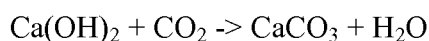

[0094] In certain embodiments of the present disclosure, a depletion media **106** may combine both O_2 and CO_2 depletion or scavenging activity. A depletion media **106** may be an oxygen and carbon dioxide sorbent material or a mixture of an oxygen sorbent and a carbon dioxide sorbent. An oxygen and carbon dioxide depletion media **106** is a depletion media **106** having an oxygen and carbon dioxide sorbent material or a mixture of the two. As used herein,

“oxygen and carbon dioxide sorbent” is a material that irreversibly binds to or combines with oxygen and carbon dioxide under the conditions of use. The term “oxygen and carbon dioxide scavenger” may be used interchangeably herein with “oxygen and carbon dioxide sorbent.” In certain embodiments according to the present disclosure, a material may bind to or combine with oxygen and carbon dioxide irreversibly. In embodiments according to the present disclosure, a material binds oxygen and carbon dioxide with higher affinity than hemoglobin. In other embodiments, a sorbent material may bind oxygen and carbon dioxide with high affinity such that the carbonic acid present in the blood or RBC cytoplasm is released and absorbed by the sorbent.

10 [0095] Non-limiting examples of CO₂ scavengers include oxygen scavengers and carbon dioxide scavengers provided by Multisorb Technologies (Buffalo, NY). Oxygen scavengers may exhibit a secondary functionality of carbon dioxide scavenging. In embodiments according to the present disclosure, O₂ depletion media and CO₂ depletion media may be blended to a desired ratio to achieve desired results.

15 [0096] In embodiments according to the present disclosure, depletion media **106** may be incorporated into, or provided to, a depletion chamber **102** in various forms. As used herein, depletion media **106** provides for, and includes, depletion media comprising oxygen sorbents, carbon dioxide sorbents and combined oxygen and carbon dioxide sorbents. It will be appreciated that sorbents can be incorporated into storage receptacles and bags in any known form, such as in sachets, patches, coatings, pockets, and packets.

20 [0097] According to some non-limiting embodiments of the present disclosure, storage receptacles for depletion media **106** may include small sachets, pockets, bags, receptacles or packets (each may be used interchangeably). The configurations of the packet and the chemistry contained in depletion media **106** may be different for each depletion chamber **102** to optimize performance. Referring to Figures 1A-D, 2A-C, 3A-C, and 4A-C, depletion media **106** may be provided to a depletion chamber **102** as one or more packets of a depletion media **106**. In some embodiments, several packets of oxygen and carbon dioxide depletion media **106** could be placed in each depletion chamber **102**, or a single longer, or larger, packet of oxygen and carbon dioxide depletion media **106** could be used. In other embodiments, oxygen depletion media **106** and carbon dioxide depletion media **106** could be included as separate packets. In certain
30 embodiments having more than one depletion chamber **102**, the configuration of the packet and

the chemistry contained in the depletion media **106** could be different for each depletion chamber **102** to optimize performance. Similarly, in certain embodiments, one or more depletion chambers **102** may be configured to deplete O₂, and another one or more depletion chambers **102** may be configured to deplete CO₂.

5 **[0098]** In some embodiments, depletion media **106** may be contained within a gas permeable membrane, film or material. In certain embodiments, a small sachet or packet may be made of a silicone or siloxane material with high oxygen permeability. In some embodiments, the sachet or packet may be prepared from a biocompatible material. In an embodiment, a sachet or packet may have a wall thickness of less than 0.13 mm thickness to ensure that O₂
10 permeability ceases to become the rate-limiting step. In other embodiments, a sachet or packet may be made from materials such as 0.15 mm thick silicone membrane. In further embodiments, a sachet or packet for receiving a depletion media **106** may be made from materials such as PTFE or other fluoropolymer. Included and provide for in the present disclosure are sachets or packets that are prepared using the gas permeable membranes as provided below. In certain
15 embodiments, the gas permeable membrane is an olefin fiber. In other embodiments, the gas permeable membrane is a flash-spun high-density polyethylene fiber.

[0099] In embodiments according to the present disclosure, sachets, pockets, bags, packets or receptacle for holding a depletion media **106** may be shaped or formed to increase the surface area. In an embodiment, a sachet or packet may be formed with a surface texture to
20 increase the surface area. In other embodiments, a sachet may be a molded element with surface texture to increase the surface area. In an embodiment, a sachet or packet may have a comb-like geometry for rapid gas depletion. A sachet having a depletion media **106** may have a rectangular shape such as, for example, a 4" x 6" rectangle, although other sizes are possible. In an embodiment, the depletion media may be in a sachet that is 6 cm x 6 cm (*e.g.*, 36 cm²).

25 **[0100]** In embodiments according to the present disclosure, depletion media **106** may be prepared as a macroporous structure. In some embodiments, the macroporous structure may be a fibrous material, a foam or a microsphere. As used herein, a macroporous structure is a material or materials that is porous to particles of about 5 to 10 microns. A macroporous structure may be a weaved fiber, random fiber or a packed bed having layers, a packed bed having a
30 heterogeneous mix of particles. Macroporous structures may include micro or macroparticles embedded or entrapped in a fibrous or foam structure. Macroporous structures may include

micro or macroparticles contained in a sachet or packet as provided above. Macroporous structures of depletion media **106** may be incorporated into the sachets, packets and pockets as provided above.

5 [0101] Porous or micro-void structures also have increased surface areas available for reaction with oxygen or oxygen and carbon dioxide. In some embodiments, the surface area of the macroporous structure may be a fiber having a surface area capable of removing O₂, CO₂, or a combination thereof. In some embodiments the surface area may be at least 5 x 10³ cm²/g media. In an embodiment, the surface area may be from 10 cm² to 2000 cm². In another embodiment, the surface area may be from 20 cm² to 1000 cm². For fibers, the surface area may
10 be determined based on the diameter of the fiber.

[0102] In an embodiment, a depletion media **106** may have a bulk density of from 0.01 g/cm³ to 0.7 g/cm³ and has an average distance between adjacent fibers of between 7 gm to 300 gm. In an embodiment, the bulk density of a depletion media **106** may be from 0.001 g/cm³ to 0.7 g/cm³. In another embodiment, the bulk density of the depletion media **106** may be from
15 0.10 g/cm³ to 0.5 g/cm³. As used herein, the term “bulk density” means a numerical value expressed in g/cm³ obtained by dividing the weight (in gram) of the mass of fibers by the volume (in cm³) of the mass of fibers.

[0103] Removal of oxygen from a blood product involves a number of steps. Given the majority of the oxygen is bound to hemoglobin within the red blood cells, in order to remove the
20 O₂, the oxygen needs to be released to the plasma. Oxygen in the plasma then has to diffuse to the surface of the depletion media **106** by passing through gas permeable barrier **107**. At the depletion media **106** surface the oxygen can either react immediately with reactive groups on the surface, or dissolve in the polymer matrix (*e.g.*, a fiber or microparticle). Once dissolved in the polymer matrix, O₂ can react with groups present within the polymer matrix.

25 [0104] In embodiments according to the present disclosure, depletion media **106** can be formed inside the pores of porous micro glass fibers. The encapsulation of transition-metal complexes within the pores of a porous material may be achieved by using a ship-in-a-bottle synthesis in which the final molecule is prepared inside the pores by reacting smaller precursors. After the synthesis, the large molecule may remain “mechanically entrapped” and encapsulated
30 inside the pores with some restricted conformation and arrangement. A cobalt phthalocyanine/porous glass composite fiber for oxygen separation can be prepared by ship-in-a-

bottle synthesis where encapsulation of cobalt phthalocyanine into pores of porous glass fibers is achieved by chemical vapor deposition using 1,2-dicyanobenzene. *See*, Kuraoka *et al.*, “Ship-in-a-bottle synthesis of a cobalt phthalocyanine/porous glass composite membrane for oxygen separation,” *Journal of Membrane Science*, 286(1-2):12-14 (2006), herein incorporated by
5 reference in its entirety. In some embodiments, porous glass fibers may be manufactured as provided in Beaver *et al.*, U.S. Patent No. 4,748,121, issued May 31, 1988, entitled “Porous Glass Fibers with Immobilized Biochemically Active Material,” herein incorporated by reference in its entirety. In another embodiment, a depletion media **106** can be formed as a porous sheet product using papermaking/non-woven wet-laid equipment. Sheets with O₂ scavenging
10 formulations such as those described in Inoue, U.S. Patent No. 4,769,175, issued September 6, 1988, entitled “Sheet-like, Oxygen-Scavenging Agent,” herein incorporated by reference in its entirety, can be formed and then encapsulated with a silicone film.

[0105] In embodiments according to the present disclosure, depletion media **106** may be encapsulated into microspheres. For example, silicones can form self-leveling, adhesive films.
15 Silicone elastomers based on dimethyl silicone polymers that contain polar moieties (polyethylene oxide substituents, *e.g.*, Dow Corning® 9011 Silicone Elastomer Blend) and low cross-link density make effective emulsifiers for preparing water-in-silicone emulsions. By modifying the water-in-silicone emulsion, depletion media **106** can be incorporated into aqueous emulsions of ultra-high molecular weight silicones (Dow Corning® HMW 2220 Non Ionic
20 Emulsion). In certain embodiments, the addition of ethylene oxide or propylene oxide polymer chains can aid emulsification during formulation and improve compatibility with polar materials. In other embodiments, the depletion media **106** as microspheres may be incorporated into the sachets, packets and bags as provided above.

[0106] In embodiments according to the present disclosure, mono-dispersed micro-beads
25 of polydimethylsiloxane (PDMS) can be created in a microfluidic system using flow-focusing. A PDMS precursor solution may be dispersed into micro-droplets within an aqueous continuous phase. These droplets may then be collected and thermally cured into solid micro-beads. These techniques allow incorporation of depletion media **106** into the PDMS micro-beads. The flow-focusing mechanism creates droplets of PDMS precursors in an aqueous continuous phase
30 bearing the surfactant, sodium dodecyl sulfate (SDS). *See*, for example, Jiang *et al.*,

“Microfluidic synthesis of monodisperse PDMS microbeads as discrete oxygen sensors,” *Soft Matter*, 8:923-926 (2006), herein incorporated by reference in its entirety.

[0107] In an embodiment of the present disclosure, the silicone elastomer may be Sylgard® 184. Sylgard® 184, a common PDMS elastomer kit from Dow Corning®, can be used
5 as the dispersed phase. Sylgard® 184 is composed of two fluids, Part A (base, consisting of vinyl-terminated siloxane oligomers) and Part B (curing agent, consisting of siloxane oligomers and catalyst), that have to be mixed and thermally cured to form the final PDMS polymer. The ratios of Part A and Part B may be adjusted to decrease the viscosity for generating stable droplets. In embodiments according to the present disclosure, depletion media **106** can be
10 directly added to the PDMS precursor solution.

[0108] In other embodiments, microspheres may be created with coaxial electrohydrodynamic atomization (CEHDA). This process can generate droplets down to 1 to 2 mm (*see*, Ganan-Calvo *et al.*, “Current and droplet size in the electrospraying of liquids. Scaling laws,” *J. Aerosol Sci.*, 28:249-275 (1997); and Jayasinghe *et al.*, “Controlled deposition of nano-
15 particle clusters by electrohydrodynamic atomization,” *Nanotechnology*, 15:1519-1523 (2004)). An aqueous solution of depletion media **106** may be created and pumped through an inner capillary while a PDMS solution is pumped through the outer capillary. A several kilovolt potential difference is applied between the capillary and ground electrode to develop a Taylor Cone (conical shaped liquid meniscus at the capillary outlet). The high charge density creates a
20 thin jet which breaks down into droplets creating the microsphere particles. The resulting microspheres may then be collected and thermally cured.

[0109] In other embodiments, microspheres can also be formed as taught in Ziemelis, U.S. Patent No. 4,370,160, issued January 25, 1983, entitled “Process for Preparing Silicone Micro-Particles,” or inorganic sorbent can be incorporated into microspheres as described in
25 Morita *et al.*, U.S. Patent No. 5,387,624, issued February 7, 1997, entitled “Method for the Preparation of a Powder Mixture Composed of Cured Silicone Microparticles and Inorganic Microparticles.” The inorganic sorbent can also be blended into the silicone as described in Hottle *et al.*, U.S. Patent 6,210,601, issued April 3, 2001, entitled “Method of Making an Oxygen Scavenging Sealant Composition.” Each of these patents is hereby incorporated by reference in
30 its entirety.

[0110] In other embodiments according to the present disclosure, a lower concentration or partial pressure of a gas of depletion chamber **115** may be achieved by providing a depletion gas **114**. A depletion gas **114** is an oxygen free gas, a carbon dioxide free gas, or an oxygen and carbon dioxide free gas. Several gases including, but not limited to, argon, helium, and nitrogen
5 may be used as a depletion gas **114**. In certain embodiments, a depletion gas **114** may be a mixture. In some embodiments, a depletion gas **114** may include CO₂.

[0111] In embodiments according to the present disclosure, a depletion device may combine one or more depletion chambers **102** that have either a depletion media **106** or depletion gas **114**. In an embodiment, a depletion device may have a depletion chamber **102** with a
10 depletion media **106** and a depletion chamber **115** having a depletion gas **114**. In another embodiment, a depletion device may have two depletion chambers **102** having a depletion media **106** and a depletion chamber **115** having a depletion gas **114**. In other embodiments, a depletion device may have a depletion chamber **102** with a depletion media **106** and two depletion chambers **115** having a depletion gas **114**.

[0112] In certain embodiments, a depletion gas **114** may be oxygen free and have a non-zero partial pressure of carbon dioxide. In an embodiment, the partial pressure of oxygen is at or
15 near zero mmHg and the partial pressure of carbon dioxide is 5 mmHg (5 Torr). In another embodiment, the partial pressure of oxygen is at or near zero mmHG and carbon dioxide is less than 5 mmHg. In a further embodiment, the partial pressure of oxygen is at or near zero mmHG and carbon dioxide is at or near zero mmHg. In an embodiment, a pCO₂ is about 5 mmHg and a pO₂ is about 10 mmHg. In another embodiment, O₂ may be depleted to a level of about 1 part
20 per billion (ppb) and CO₂ may be depleted to at least 1 part per million (ppm). In another embodiment, an oxygen free gas may have CO₂ at about 10 mmHg. In another embodiment, an oxygen free gas may have CO₂ at about 20 mmHg or more. In embodiments according to the present disclosure, an oxygen free gas may have 5, 10, 15, 20, 25, 30, 35, 40 or 45 mmHg of
25 CO₂. In yet another embodiment, an oxygen free gas may have CO₂ at about zero to 50 mmHg. In an embodiment, an oxygen free, carbon dioxide reduced gas may be argon having about 5 mmHg CO₂.

[0113] By way of non-limiting illustration, Figures 8A-C and 9A-C provide exemplary
30 embodiments of gas depletion devices having at least one gas depletion chamber **115** having one or more gas inlets **111** and one or more gas outlets **112**. In some embodiments, a gas depletion

device may have two, three or four gas inlets **111** and two, three or four gas outlets **112**.

Referring to Figure 8A, a gas depletion device may have two gas inlets **111** and two gas outlets **112**. It should be readily understood that gas inlets **111** and gas outlets **112** may be arranged to provide a countercurrent flow of a depletion gas **114** relative to the flow of liquid through a liquid chamber **101**. In other embodiments, the flow of depletion gas **114** relative to the flow of liquid in liquid chamber **101** may alternate between a counter-current flow and a concurrent flow.

[0114] In an embodiment according to the present disclosure, gas inlets **111** and gas outlets **112** may be arranged in parallel such that each gas depletion chamber **115** is provided a separate stream of depletion gas **114**. In some embodiments, one or more gas depletion chambers **115** may be connected in series by connecting a first gas outlet **112** to a second gas inlet **111**, either directly or through a connecting tube. Similarly, in some embodiments, a second gas outlet **112** may be connected to a third gas inlet **111**, either directly or through a connecting tube. According to embodiments of the present disclosure, the number of gas depletion chambers **115** that may be connected in series may be two or more. In another embodiment, three or more gas depletion chambers **115** may be connected in series. In another embodiment, four or more gas depletion chambers **115** may be connected in series. In another embodiment, five or more gas depletion chambers **115** may be connected in series. It should be apparent that the number of gas depletion chambers that may be connected in series depends on the flow of depletion gas **114** such that the concentration or partial pressure of oxygen, carbon dioxide, or both is less than the concentration or partial pressure of oxygen, carbon dioxide, or both in the liquid chamber.

[0115] Referring to Figures 9A-C, a gas depletion device of the present disclosure may have three or more depletion chambers **115**. As shown, a device having three depletion chambers **115** may be supplied with three streams of depletion gas **114** in parallel through separate gas inlets **111**. In some embodiments, depletion gas **114** may be provided in series as described above such that a first gas outlet **112** is connected directly or through tubing to a second gas inlet **111**. In other embodiments, depletion gas **114** may be provided as a countercurrent flow of depletion gas relative to the flow of liquid in liquid chambers **101**. In further embodiments, the flow of depletion gas relative to the flow of liquid in liquid chamber **101** may alternate between a counter-current flow and a concurrent flow. In embodiments

according to the present disclosure, a gas depletion device having more than one gas depletion chamber **115** may be supplied with a single source of depletion gas **114**. Accordingly, each gas inlet **111** for each depletion chamber **115** would be supplied through a manifold which splits and divides the flow of depletion gas **114** to each separate depletion chamber **115**. Similarly, a gas depletion device of the present disclosure having a single source of depletion gas may further include an outlet manifold which combines the exhaust gas flow from one or more gas outlets **112**.

[**0116**] As illustrated in Figures 8A-C, 9A-C, and 10A-C, a gas depletion chamber **115** may include one or more gas flow control features **113**. As provided in the illustrations, two gas flow control features **113** (shown as horizontal bars) provide for the mixing of depletion gas **114** to maximize the concentration or partial pressure difference between the gas depletion chamber **115** and liquid chambers **101** thereby increasing the efficiency and rate of gas diffusion across one or more gas permeable barriers **107**. In yet other embodiments, the geometry of a gas flow control feature **113** may be modified, as illustrated in Figures 11A-C. In further embodiments, a gas depletion device of the present disclosure may include a combination of gas flow control features **113**. In embodiments according to the present disclosure, flow control features may be modified to adjust for gas flow (see below). In another embodiment, the gas flow control features **113** may be modified to achieve a desired partial pressure and to avoid desiccating the liquid. In certain embodiments, the gas flow control features **113** are designed to eliminate bubble formation. In some embodiments, the gas flow control features **113** are designed to eliminate any pressure that will displace the liquid.

[**0117**] According to the present disclosure, gas permeable barriers **107** are barriers that are impermeable to a liquid and are porous to one or more gases. Gas permeable barriers **107** may be formed as a membrane, film, fiber, or mesh. In some embodiments, a gas permeable barrier **107** may be a hydrophobic porous structure. In certain embodiments, a gas permeable barrier **107** may be a low liquid permeability barrier that allows one or more gases to pass through. In some embodiments, a gas permeable barrier **107** may be impermeable to liquid through their operation at a liquid-side pressure that is below the intrusion pressure of the membrane.

[**0118**] In embodiments according to the present disclosure, a gas permeable barrier **107** may be a non porous material that is capable of high gas permeability rates. In some

embodiments, a gas permeable barrier **107** may be capable of high oxygen permeability rates. In some embodiments, a gas permeable barrier **107** may be capable of high carbon dioxide permeability rates. In further embodiments, a gas permeable barrier **107** may be capable of high oxygen and carbon dioxide permeability rates.

5 **[0119]** Gas permeable barriers **107** according to the present disclosure include membranes, films, fibers or meshes that are constructed of polymers. Non-limiting examples of polymers suitable for the preparation of gas permeable barriers **107** of the present disclosure include polyolefins, silicones, epoxies, and polyesters. In other embodiments, the gas permeable barriers **107** may be constructed from Teflon, PVDF, or polysulfone, inorganic materials
10 including ceramics, and combinations of each. Suitable materials for gas permeable barriers **107** according to the present disclosure include polysulfone, cellulose acetate, polypropylene, polyvinylidene difluoride, polyether sulfone, polyvinyl alcohol, polymethylmethacrylate, and combinations thereof. Non-limiting examples of gas permeable barriers **107** include PVDF
15 membrans manufactured by EMD Millipore having membrane codes VVHP, GVHP, HVHP, DVHP, HAWP, DAWP, AAWP, RAWP, SSWP, SMWP, SCWP, SVPP, VEPP, GEPP, EIMF, HEMF, HEPP, VVSP, GVSP, HVSP, DVSP, BVSP and SVSP.

[0120] In embodiments according to the present disclosure, gas permeable barriers **107** have an average surface pore size that may be characterized by methods known in the art such as scanning electron microscopy. In some embodiments, a gas permeable barrier **107** may have an
20 area-average surface pore size of about 8 μm or less, or less than 3 μm . By porometry or bubble point test, the average pore size of gas permeable barriers **107** may be between about 0.1 and 1 μm . In certain embodiments, the average pore size is less than 4 μm .

[0121] According to the present disclosure, gas permeable barriers **107** may be formed from at least one material selected from the group consisting of PVDF rendered hydrophilic,
25 nylon, cellulose esters, polysulfone, polyethersulfone, polypropylene rendered hydrophilic, and polyacrylonitrile. In embodiments according to the present disclosure, a hydrophilic microporous membrane may be a multilayered membrane. In an embodiment, a gas permeable barrier **107** may be a multilayered membrane having two or more materials selected from the group consisting of: PVDF rendered hydrophilic, nylon, cellulose esters, polysulfone,
30 polyethersulfone, polypropylene rendered hydrophilic, and polyacrylonitrile. Gas permeable barriers **107** of the present disclosure may be further surface modified to control cell adhesion,

protein binding and fouling. In some embodiments, a gas permeable barrier **107** may be modified to increase the hydrophilicity. In an embodiment, a polysulfone material may be combined with PVP to prepare membranes with increased hydrophilicity. In an embodiment, the gas permeable barrier **107** may be prepared from polysulfone. In an embodiment according the
5 present disclosure, a gas permeable barrier **107** may be hydrophilic microporous membrane. In other embodiments, a gas permeable barrier **107** may be formed from more than one hydrophilic microporous membrane. In some embodiments, more than one membrane may be fused together to prepare a gas permeable barrier **107**. In other embodiments, more than one membrane may be layered to prepare a gas permeable barrier **107**. In some embodiments, a layered membrane may
10 be separated by a media. In an embodiment, the media may be a depletion media as provided above.

[**0122**] In embodiments according to the present disclosure, a gas permeable barrier **107** may be less than 250 microns thick. In an embodiment, a gas permeable barrier **107** may be greater than 25 microns thick. In some embodiments, a gas permeable barrier **107** may be
15 between 25 and 250 microns thick. In other embodiments, a gas permeable barrier **107** may be between 25 and 100 or 25 and 150 microns thick. In an embodiment, a gas permeable barrier **107** may be between 50 and 100 microns thick, 75 and 100 microns thick, 50 and 150 microns thick, 75 and 150 microns thick, 100 and 250 microns thick, 150 and 250 microns thick, or between 25 and 150 microns thick.

[**0123**] The lowest oxygen saturation may be achieved by using devices in which
20 depletion media **106** is placed close to gas permeable barrier **107** and, in turn, a liquid in liquid chamber **101** to enable rapid diffusion time. Additional factors that increase gas diffusion are larger active surface area of gas permeable barrier **107**. The scavenging rates of depletion media **106** may be limited by the surface area available for reaction with oxygen or oxygen and carbon
25 dioxide and how readily the oxygen or oxygen and carbon dioxide diffuses into depletion media **106**. Surface area availability can be increased by incorporating the depletion media **106** into microparticles or microfibers as provided above.

[**0124**] In certain embodiments according to the present disclosure, a gas permeable barrier **107** may include a biocompatible leukocyte binding surface chemistry on the surface of
30 the gas permeable barrier **107** in liquid contact with a liquid chamber **101**. In certain embodiments, a liquid chamber **101** may include one or more leukocyte binding materials to

reduce the number of leukocytes in a liquid flowing in a liquid chamber **101**. In an embodiment, a gas permeable barrier **107** may further comprise one or more additional layers having a biocompatible leukocyte binding surface chemistry. In other embodiments according to the present disclosure, a device may include a separate biocompatible leukocyte binding material. In certain
5 embodiments, a biocompatible leukocyte binding material may be a membrane with a binding surface chemistry. In some embodiments, the leukocyte binding material may be a binding matrix. In other embodiments, a biocompatible leukocyte binding material may be a leukoreduction material **123**.

[**0125**] Leukoreduction materials suitable for methods of the present disclosure may be
10 prepared as either filters, fibers, microspheres or microparticles. In an embodiment, leukocyte reduction filters may be formed as described in Lee *et al.*, U.S. Patent No. 6,337,026, issued January 8, 2002, entitled "Leukocyte reduction filtration media," using micro-glass fibers. Gas permeable barriers as described above can be used as a base and then grafted PVA or Silicone can be used to coat the gas permeable barrier **107** and promote leukocyte adhesion. In another
15 embodiment, melt blown fibers as described in Pall, U.S. Patent No. 4,925,572, issued May 15, 1990, entitled "Device and method for depletion of the leukocyte content of blood and blood components," can be formed from PBT or PET and then incorporated into filter devices as taught in Pall *et al.*, U.S. Patent No. 5,229,012, issued July 20, 1993, entitled "Method for depletion of the leucocyte content of blood and blood components," and surface modified as described in
20 Gsell, U.S. Patent No. 5,443,743, issued August 22, 1995, entitled "Gas plasma treated porous medium and method of separation using same." All of which are herein incorporated by reference in their entireties.

[**0126**] In another embodiment, gas permeable barriers **107** as described above can also be surface modified as described in Bonaguidi *et al.*, U.S. Patent No. 7,775,376, issued August
25 17, 2010, entitled "Filter for the separation of leukocytes from whole blood or blood preparations, method for production of said filter, corresponding device and use thereof," hereby incorporated by reference in its entirety. In another embodiment, the monomers of Bonaguidi *et al.* may be grafted onto a silicone coating instead of polymerized. Gas permeable barriers **107** can be included into conventional leukoreduction fibers made of PBT or PET as taught in
30 Clauberg *et al.*, U.S. Patent No. 6,610,772, issued August 26, 2003, entitled "Platelet Particle Polymer Composite with Oxygen Scavenging Organic Cations," hereby incorporated by

reference in its entirety. Additional limitations and requirements of leukocyte reduction filters may be found in Watanabe *et al.*, U.S. Patent No. 4,701,267, issued October 20, 1987, entitled “Method for Removing Leukocytes,” hereby incorporated by reference in its entirety.

[0127] Depletion devices of the present disclosure having leukoreduction capabilities include and provide for the preparation of leukoreduced blood products including packed red blood cells. In an embodiment, the number of leukocytes is reduced to a level below 1000 cells/ μ l. In another embodiment, the number of leukocytes is reduced to a level below 100 cells/ μ l. In yet another embodiment, the number of leukocytes is reduced to a level below 10 cells/ μ l. In an embodiment according to the present disclosure, the number of leukocytes remaining after leukoreduction may be from 1 cell to 10 cells/ μ l. In another embodiment, the number of leukocytes remaining may be from 5 to 20 cells/ μ l. In another embodiment, the number of leukocytes remaining may be from 5 to 10 cells/ μ l, 5 to 50 cells/ μ l, 5 to 100 cells/ μ l, 10 to 20 cells/ μ l, or 5 to 100 cells/ μ l. In certain embodiments according the present disclosure, the number of leukocytes is determined by flow cytometry.

[0128] In embodiments according to the present disclosure liquid chambers **101** and gas depletion chambers **102** may contain flow control features **108** and **113**. The number, position, size and shape of the flow control features **108** and **113** may be altered to optimize the gas depletion devices of the present disclosure. In an embodiment, a flow control feature **108** may be configured to direct the flow of liquid against the gas permeable barrier **107**. In other embodiments, a flow control feature **113** may be configured to direct the flow of depletion gas **114** along a gas permeable barrier **107**.

[0129] Flow control features **108** according the present disclosure may be of different shapes and sizes. As illustrated in Figure 1D, flow control feature **108** are depicted as approximately one-half the height of the liquid chamber **101** (*see, e.g.*, Figure 1B). This ratio may be altered for different flow rates. Also as illustrated in the figures, flow control features **108** may be triangular (*see, e.g.*, Figures 1A, 1B, 2A, 2B, 3A, 4A, 8A, 9A, 10A, 12A, 13A, 14A, and 15A). In other embodiments, flow control features may be semi-circular, ovoid, square or any combination of thereof (*see, e.g.*, Figures 2A-F). As illustrated in, for example, Figures 1C, 2B, 8C and 9B, flow control features **108** may extend across the width of liquid chamber **101**. In other embodiments, flow control features **108** may include openings or gaps.

[0130] Referring to Figures 2A-F, flow control features **108** include a variety of shapes, position and number. In certain embodiments, the flow control features **108** may be positioned flush with the outside surface of inner shell **109** as shown in Figures 2A and 2B. In other embodiments, the flow control features **108** may be offset from the surface of the inner shell **109** and illustrated in Figures 2C to 2F. In certain embodiments according to the present disclosure, flow control features **108** may be triangular, rectangular or circular as illustrated in Figures 2A to 2F. In other embodiments, the flow control features **108** may be combinations of triangular, rectangular or circular shapes. In an embodiment, a flow control feature **108** may be semicircular. The flow control features **108** according to the present disclosure may be present in varying numbers. For example as illustrated in Figure 2A and 2B, there may be eight flow control figures. In other embodiments, there may be more than eight flow control features **108**, for example, 9, 10 or 11 flow control features **108**. In some embodiments, there may be fewer than eight flow control features **108**. For example there may be 1 or more flow control features **108**. In some embodiments, there may be fewer than eight flow control features **108**. In certain other embodiments, there may be 2 or more flow control features **108**. In other embodiments, there may be 3 or more flow control features **108**. In yet other embodiments, there may be 4 or more flow control features **108**. In further embodiments, there may be 5 or 6 flow control features **108**.

[0131] The number and position of flow control features **108** can also be altered to optimize the process for a specific configuration. As illustrated in Figures 1A-D, the flow features may be incorporated as flow control features **108** on alternate sides of a liquid chamber **101** and may further include an offset such that the liquid flows in a zig-zag direction as it proceeds through the liquid chamber **101** (*see, e.g.*, Figures 1A, 2A-B, 3A, 4A, 6A, 8A, 9A, 10A, 12A, 13A, and 14A). Flow control features **108** included on opposing sides of a liquid chamber **101** provide for both directing the flow of liquid against gas permeable barrier **107** and for mixing the flowing liquid to maintain disequilibrium between the concentration or partial pressure of the gas in the liquid and the concentration or partial pressure in the depletion chamber **102**.

[0132] The number and position of flow control features **108** can also be altered to optimize the process for a specific configuration. A gas depletion device may have one or more flow control features **108**. In an embodiment, a gas depletion device may have two or more flow

control features **108**. In another embodiment, a gas depletion device may have three or more flow control features **108**. In other embodiments, a gas depletion device may have four or more flow control features **108**. In another embodiment, a gas depletion device may have five or more flow control features **108**. In some embodiments there may be six, seven or eight or more flow control features **108**.

[0133] Flow control features **113** according to the present disclosure may be of different shapes and sizes. As illustrated in Figures 8A, 9A, and 10A, gas flow control features **113** are depicted that direct the flow of gas around the outside of the device so that the flow runs parallel to the gas permeable membrane **107**. Gas flow control features **113** may introduce turbulence in the gas flow to ensure mixing and maintain the rate of diffusion across a gas permeable membrane **107**. Also as illustrated in the figures, gas flow control features **113** may be triangular. In other embodiments, flow control features may be semi-circular, ovoid, square or any combination of thereof (see also, Figures 2A-F and Figures 11A-C). As illustrated in Figures 8B, 9B and 10B, gas flow control features **113** may extend across less than the width of gas depletion chamber **115**. In other embodiments, gas flow control features **113** may include openings or gaps to provide for branching and joining of the gas flow.

[0134] The number and position of gas flow control features **113** can also be altered to optimize the process for a specific configuration. As illustrated for flow control features **108**, gas flow features **113** may be incorporated on alternate sides of a gas depletion chamber **102** and may further include an offset such that the gas flows in a zig-zag direction as it proceeds through the gas depletion chamber **102**. Gas flow control features **113** may be included on opposing sides of a gas depletion chamber **102** to provide for both directing the flow of liquid against gas permeable barrier **107** and for mixing the flowing gas to maintain disequilibrium between the concentration or partial pressure of the gas in the liquid and the concentration or partial pressure in the depletion gas.

[0135] The number and position of gas flow control features **113** can also be altered to optimize the process for a specific configuration. A gas depletion device may have one or more flow control features **113**. In an embodiment, a gas depletion device may have two or more flow control features **113**. In another embodiment, a gas depletion device may have three or more flow control features **113**. In other embodiments, a gas depletion device may have four or more flow control features **113**. In another embodiment, a gas depletion device may have five or more

flow control features **113**. In some embodiments, there may be six, seven or eight or more flow control features **113**.

[0136] Referring to Figures 5A-C and 7A-C, a depletion device according to the present disclosure may include one or more flexible or expandable depletion chambers **102** and one or more flexible or expandable liquid chambers **101**. To provide for mixing and efficient diffusion of a gas from a liquid chamber **101** to a depletion chamber **102**, a depletion chamber **102** of a flexible depletion device may include one or more flow control features **108**. In certain embodiments, flow control features are provided to direct the liquid flow in a pattern with corners set at variable angles. Referring to Figures 6A-C, flow control features may include an indirect path **133**. In certain embodiments, the liquid flow would proceed in a zig-zag manner. In some embodiments, the flow may follow a regular pattern, branching and rejoining prior to exiting through liquid outlet **105**. In other embodiments, the flow may follow an irregular pattern. In some embodiments, the liquid flow may be divided into two or more individual flows. In other embodiments, the liquid flow may be divided 2, 4, 6 or more times. In certain embodiments with divided flows, the flows may be recombined before exiting through an outlet **105**.

[0137] Depletion devices according to the present disclosure include at least one inlet **104** and at least one outlet **105**. Although depicted in the illustrations with inlets **104** at the top and outlets **105** at the bottom, the flow of liquids and gases may be reversed. In some embodiments, the flows are arranged to provide for a countercurrent flow. In some embodiments, an outlet **105** may be connected to an inlet **104**, for example as illustrated in Figures 9A-C, device **900**. In an embodiment, the liquid chambers **101** may be connected via inlets **104** and outlets **105** to provide for parallel flow.

[0138] Depletion devices according to the present disclosure may comprise one or more liquid chambers **101** and one or more depletion chambers **102**. In some embodiments, chambers **101** and **102** may be stacked and combined into a single depletion device. In a stacked configuration, a depletion device may arrange the liquid chambers **101** in a serial or parallel configuration in liquid communication with each other. According to the present disclosure, stacking the depletion chambers **102** and liquid chambers **101** combined with altering the internal features and ratios of the liquid chamber **109** and the control features **108** may be continued to create as many layers as required to meet the gas depletion process requirements.

In certain embodiments, a depletion device may provide for the parallel flow of the fluid through two or more liquid chambers **101** by dividing the fluid flow using a splitter **130** as illustrated in Figure 10A. In a parallel chambered depletion device, the fluid flow through liquid outlet **105** is rejoined with joiner **131**. In an embodiment, for example as illustrated in Figures 10A-C, a device **1000** may have two parallel liquid chambers **101** and three gas depletion chambers **114**. In other embodiments, three or more parallel liquid chambers **101** may be provided. In yet other embodiments, a combination of parallel and serial liquid chambers **101** may be provided.

[**0139**] In other embodiments, depletion devices according to the present disclosure may further include an anaerobic plasma port **116** as illustrated in Figures 7A-C and 8A-C.

Included and provided for in the present disclosure are gas addition devices having a structure similar to the structure of a depletion device similar to those illustrated in Figures 8A-C and 9A-C provided above. A gas addition device may supply one or more gases to an oxygen or oxygen and carbon dioxide depleted blood product prior to transfusion. A gas addition device according to the present disclosure may have one or more streams of an addition gas. For example, a gas addition device may have an oxygen addition gas and a nitric oxide addition gas provided separately to a single gas addition device similar to one illustrated in Figures 9A-C.

[**0140**] Referring to Figures 16A-C, a gas addition device may provide for the reoxygenation of an anaerobic liquid, such as anaerobic stored red blood cells, prior to transfusion into a patient in need. For example, anaerobic packed red blood cells enter through liquid inlet **104** and flow through liquid chamber **101** having flow control features **108**. As the packed red blood cells pass through the device, oxygen provided through gas addition ports **128** diffuse through gas permeable barriers **107** and are bound by hemoglobin in the red blood cells. As illustrated in device **1600**, the gas addition gas ports **128** provide for the passage of ambient air through outer shell **103**. In other embodiments, addition ports **128** may further comprise inlets capable of connecting to a gas supply to provide an oxygen rich gas.

[**0141**] Gas addition devices according to the present disclosure may provide a gas to a gas depleted blood product prior to transfusion. A gas addition device of the present disclosure includes devices as described above wherein a depletion gas **114** is replaced by an addition gas and a depletion chamber **102** is replaced by an addition chamber. In an addition device, a gas flows through one or more gas addition chambers, thereby providing a source of addition gas at a higher concentration or partial pressure than a liquid flowing in a liquid chamber **101**. As

provided above, a gas addition chamber is separated from a liquid chamber by a gas permeable barrier. In embodiments of a gas addition device, a liquid chamber is provided with one of more flow control features **108** to ensure mixing of the liquid and maintenance of a strong diffusive force provided by the difference in concentration or partial pressure of the gas. Similarly, a gas addition chamber may also include flow control features **113** to ensure mixing and gas equilibration.

[0142] In embodiments according to the present disclosure, an addition gas may be an oxygen containing gas. In an embodiment, an oxygen containing gas may comprise ambient air having about 20% oxygen. In another embodiment, an addition gas may have an increased oxygen percentage compared to ambient air. In an embodiment, the percent oxygen may be more than 20%. In another embodiment, the percent oxygen may be more than 30%. In another embodiment, the percent oxygen may be 40%, 50% or more. In yet another embodiment, the addition gas may be pure oxygen. In other embodiments, the oxygen containing gas may have less than 20% oxygen. In an embodiment, the addition gas may have 15% oxygen or 10% oxygen, or less.

[0143] In embodiments according to the present disclosure, an addition gas may be a nitric oxide containing gas. In some embodiments, the addition of NO may occur prior to the addition of oxygen in preparation for transfusion due to the inherent instability of NO in the presence of oxygen. In certain embodiments, an addition gas having nitric oxide is provided to an anaerobic blood product using a gas addition device prior to the addition of O₂ by a gas addition device. In other embodiments, an integrated NO/O₂ addition device maintains a first stream of NO addition gas in a gas addition chamber **134** thus supplying an adjacent liquid chamber **101** with NO. A second oxygen addition gas, provided to a second gas addition chamber provides a source of oxygen to a second liquid chamber in liquid communication with a first NO gas supplied liquid chamber. One or more NO addition steps and one or more O₂ addition steps may be provided by stacking gas addition chambers and liquid chambers as provided above. In some embodiments, an addition gas may comprise carbon dioxide together with or in a separate gas stream. In an embodiment, an addition gas may include 5% CO₂. In another embodiment, an addition gas may include 2.5% CO₂. In a further embodiment, an addition gas may include from 1 to 5% CO₂. In other embodiments, an addition gas may include

from 2 to 4% or 2 to 5% CO₂. Other embodiments may include more than 5% CO₂ in an addition gas.

5 [0144] Depletion devices according the present disclosure may be used with anaerobic storage bags that are capable of storing red blood cells or a blood product anaerobically and in a CO₂ depleted state.

[0145] Storage bags compatible with methods and systems of the present disclosure may be a laminated bag having an oxygen and carbon dioxide sorbent or a secondary bag containing an oxygen and carbon dioxide sorbent. In other embodiments, a compatible storage bag may comprise an inner blood storage bag having DEHP-plasticized PVC in contact with RBCs or blood product. A compatible storage bag may further comprise an outer transparent oxygen barrier film (*e.g.*, nylon polymer) laminated to the outer surface inner blood bag. In other compatible embodiments, a storage bag may be a bag within a bag, wherein the outermost bag comprises an oxygen barrier film. Storage bags compatible with blood products produced by the depletion devices according to the present disclosure include storage bags that include one or more sorbents, including oxygen sorbents.

15 [0146] Exemplary storage bags may be found, for example, in U.S. Application No. 12/901,350, filed October 8, 2010, entitled “Blood Storage Bag System and Depletion Devices with Oxygen and Carbon Dioxide Depletion Capabilities,” and herein incorporated by reference in its entirety.

20 [0147] Blood products suitable for use in a depletion device of the present disclosure include platelet depleted blood products. In an embodiment, a suitable blood product is a platelet depleted packed red blood cell blood product. Platelets, in contrast to red blood cells, require O₂ for metabolism. Thus, platelets may be damaged by depletion of oxygen and storage under anaerobic conditions. Accordingly, removal of platelets prior to, or after treatment with a device of the present disclosure may avoid the release of substances that may compromise the quality of a stored depleted blood product. Exemplary platelet depletion coatings are provided in, for example, in U.S. Patent No. 4,880,548, entitled “Device and method for separating leucocytes from platelet concentrate,” issued November 14, 1989, U.S. Patent No. 5,783,094, entitled “Whole blood and platelet leukocyte filtration method,” issued July 21, 1998, U.S. Patent No. 7,721,898, entitled “Coating material for leukocyte removal filter and the filter,” issued May 25, 25 30 2012, and U.S. Patent No. 7,775,376, entitled “Filter for the separation of leukocytes from whole

blood or blood preparations, method for production of said filter, corresponding device and use thereof,” issued August 17, 2010, each of which is incorporated herein in its entirety.

[0148] The present disclosure provides for, and includes methods for the use of a device or devices disclosed herein and described below. Provided for and included are methods for
5 preparing an oxygen or oxygen and carbon dioxide depleted blood product using a device or devices of the present disclosure. The present disclosure further provides for, and includes, methods for the extended storage of a blood product using a disclosed depletion device. A method may be designed using a device or devices disclosed herein that adopts a combination of the steps described herein. Blood products suitable for depletion methods using a disclosed
10 device include, for example, whole blood, packed red blood cells, platelet depleted whole blood, platelet depleted packed red blood cells, edited whole blood, and edited packed red blood cells.

[0149] The present disclosure provides for and includes a depletion device having an enclosure, one or more liquid chambers, one or more depletion chambers, at least one gas permeable barrier, at least one liquid inlet and at least one liquid outlet. Methods according to
15 the present disclosure may include collection of blood, passage through a described depletion device, storage in an anaerobic storage bag, re-oxygenation using a device of the present disclosure, and transfusion into a patient. Methods may further include leukoreduction steps, platelet reduction or separation steps, red blood cell editing steps, pathogen inactivation steps and volume reduction steps. As provided in the present disclosure, method steps may be
20 included in various combinations to provide a blood product suitable for transfusion into a patient in need thereof. The methods of the present disclosure also provide and include methods to enhance the long term storage of blood products.

[0150] The present disclosure provides for, and includes, a method for preparing red blood cells (RBCs) including obtaining whole blood, separating the RBCs from the whole blood
25 to form packed RBCs, depleting oxygen to form oxygen depleted RBCs or depleting oxygen and carbon dioxide to form oxygen and carbon dioxide depleted RBCs using a device of the present disclosure and storing the oxygen depleted or oxygen and carbon dioxide depleted RBCs in an anaerobic storage environment to maintain an oxygen depleted or oxygen and carbon dioxide depleted condition.

[0151] A method according to the present disclosure provides for the preparation of a
30 depleted blood product using a disclosed device. In an embodiment, the method may include a

device that includes an oxygen depletion media **106** or a depletion gas **114** to prepare an oxygen depleted whole blood product. In an embodiment, the method may include a device that includes an oxygen and carbon dioxide depletion media **106** or a depletion gas **114** to prepare an oxygen and carbon dioxide depleted whole blood product.

5 **[0152]** Methods of the present invention include methods of preparing a blood product for depletion using a disclosed device. In an embodiment, whole blood may be obtained from a donor and applied directly to a device of the present invention. In another embodiment, packed red blood cells may be prepared from whole blood or whole donor blood. Packed red blood cells (pRBC) may be prepared from whole blood using centrifugation techniques commonly known in
10 the art. Packed red blood cells may also be prepared using filtration methods. Packed red blood cells may contain an additive solution. Packed red blood cells can also be collected by aphaeresis techniques such that components are separated during collection. Packed red blood cells may be depleted of oxygen or oxygen and carbon dioxide using a depletion device of the present disclosure.

15 **[0153]** A device of the present disclosure may be used with methods to prepare leukoreduced, depleted blood products. In an embodiment, a blood product may be passed through a leukoreduction filter to remove leukocytes prior to flowing through a depletion device of the present disclosure. In other embodiments, a depletion device of the present invention may be prepared to include leukoreduction as discussed above. In an embodiment, a device of the
20 claimed invention includes a leukoreduction coating on a gas permeable barrier **107**. In another embodiment, a leukoreduction prefilter may be incorporated into a disclosed depletion device. In a further embodiment, a leukoreduction post-filter may be incorporated into a disclosed depletion device.

[0154] The present disclosure provides for, and includes, methods for preparing depleted
25 blood products having edited red blood cell populations using a device of the present disclosure. Editing can include removing RBCs that exhibit indications of being compromised. Editing RBCs is the process of identifying and removing blood cells that have a poor likelihood of surviving the transfusion process or will likely die shortly after transfusion. Editing moribund RBCs, or dead or dying red blood cells, may occur before or after processing a blood product
30 using a device, or devices of the present disclosure. For example, editing can be performed immediately before transfusion after storage in an anaerobic storage bag.

[0155] Editing can be important because a leading cause of morbidity and mortality to transfused patients is the non-viable portion of the blood that is transfused independent of any pathogen transmission. RBCs that are compromised or that will be removed by the spleen by the reticuloendothelial system shortly after transfusion may threaten to overwhelm the already
5 compromised recipient. Up to 25% of transfused cells are removed by recipient in the first twenty four hours after transfusion. These removed cells are harmful because they contribute immediately to the excess iron burden of the recipient, which may be a critical parameter for chronically or massively transfused patients. Also, these cells may cause capillary blockage due to reduced deformability or aggregate formation, leading to poor tissue perfusion and even organ
10 failure. Thus, substantial benefits are expected if one can remove these less viable RBCs prior to transfusion.

[0156] There are several techniques that may be used to edit the red blood cells. The first technique is a centrifugation process to separate old and young RBCs before storage based on characteristic buoyancies of young and old RBCs.

[0157] A second technique applies a biomechanical stress, such as an osmotic shock, to hemolyze weak cells before or after storage in combination with a buffer exchange step. The applied biomechanical stress immediately identifies those cells that are weak to rapidly contrast with the stronger RBCs to enable mechanical separation. The weak RBCs are those that contribute to recipient morbidity and mortality, particularly with individuals with already
15 compromised or overloaded immune systems. Up to 25% of RBCs that arrive to a recipient are already dead and can have deleterious effects on the recipient. By editing the RBCs, that number can be reduce by 50% to 75%.

[0158] A third technique applies to the deformability of the RBCs. Bump array microfluidic devices containing staggered pillars (Huang, L.R., *et al.*, "Continuous particle separation through deterministic lateral displacement," *Science*, 304(5673): 987-90 (2004),
25 herein incorporated by reference in its entirety), allow deformable RBCs to pass through the pillars while deformable RBCs cannot pass through the pillars and are bumped into separate channels.

[0159] A further technique for editing the RBCs uses a filter system to remove RBC
30 exhibiting a specific surface marker. RBCs exhibiting known surface markers such as

phosphatidylserine or aggregated protein 3 can be trapped by a filter surface modified with high affinity ligand (*e.g.*, Annexin IV or antibodies against specific surface marker protein).

5 [0160] An additional technique uses the same high affinity ligands (*e.g.*, specific surface markers) in the second technique, conjugated to make a multimeric molecule such that RBCs exhibiting target surface markers form aggregates. This can then be separated by filtration or centrifugation.

[0161] Method of preparing blood products using the devices of the present disclosure may include one or more steps of lymphocyte inactivation and pathogen elimination using gamma- or X-ray irradiation (irradiation generally).

10 [0162] Gamma-irradiation abrogates proliferation of T-lymphocytes by damaging the DNA directly and via reactive oxygen species (ROS), namely hydroxyl radicals produced during gamma-radiolysis of water. Although red blood cells (RBC) do not contain DNA, ROS generated by gamma-irradiation have been shown to cause significant damage to the RBC. The major damage observed includes: i) increased hemolysis; ii) increased K^+ leak; iii) reduction in post-transfusion survival; and iv) reduced deformability. Such damage is similar to, but an
15 exaggerated form of storage-induced damage of RBC. The compromised status of RBC is well known to the physicians who administer such compromised RBC. The FDA mandates restricted use of such RBC in terms of shortened shelf life after gamma-irradiation (14 days) and/or 28 days total shelf life for irradiated units.

20 [0163] The irradiation of blood components has received increased attention due to increasing categories of patients eligible to receive such blood to prevent transfusion-associated graft versus host disease. However, irradiation leads enhancement of storage lesions, which could have deleterious effects when such blood is transfused. It is well known in the field that the main deleterious side-effect of radiation on RBC is oxidative damage caused by ROS.

25 [0164] In methods of the present disclosure, a blood product depleted using a device or devices may be irradiated so that it may be transfused to patients requiring irradiated blood products. In an embodiment, a red blood cell composition may be depleted of oxygen or oxygen and carbon dioxide using a described depletion device and then irradiated prior to storage in a gas impermeable storage bag. In another embodiment, a blood product may be depleted of
30 oxygen or oxygen and carbon dioxide using a described depletion device, stored in an anaerobic environment, and irradiate prior to transfusion.

[0165] Exemplary methods for irradiation of blood products are illustrated in U.S. Patent Application No. 13/289,722, filed November 4, 2011, hereby incorporated by reference in its entirety.

[0166] Methods of preparing blood products using the devices of the present disclosure may include one or more buffer exchange steps. In an embodiment, a buffer may be exchanged by centrifugation to sediment the cells, removal of the supernatant and replacement of the liquid with a buffer. In an embodiment, the buffer may be an isotonic buffer. In yet another embodiment, buffer replacement may be accomplished by filtration of the cells and addition of a replacement buffer.

[0167] As provided above, devices of the present disclosure provide for the introduction of one or more gases to a depleted blood product. In an embodiment, an oxygen or oxygen and carbon dioxide depleted blood product prepared using a device of the present disclosure may be prepared for transfusion by a method using a gas addition device as described above. In an embodiment, the gas addition device restores O₂ to a blood product such that oxygen saturation is at, or near, 100%. In a method according to the present disclosure, a storage bag containing a depleted blood product is connected to a liquid inlet **104** using a tube, the blood product is allowed to flow through the liquid chamber **101** while an oxygen containing addition gas is provided to gas addition chamber **134** through gas addition ports **128**. As a liquid, for example anaerobic stored red blood cells, flows through liquid chamber **101**, it absorbs oxygen from a gas flowing through gas addition chamber **134** that diffuses across gas permeable barrier **107**. In certain embodiments, the addition ports provide for the flow of ambient air through the device. In other embodiments, addition ports **128** may provide for an oxygen rich gas source to be provided. Any suitable gas may be provided to a gas addition device through addition port **128** including ambient air, pure oxygen and mixtures of oxygen and carbon dioxide. In other embodiments, an addition gas may include NO, either together with O₂ or provided separately. In an embodiment, NO may be provided to an addition device having two gas addition streams and two or more addition chambers, where one gas stream and addition chamber provides O₂, and a second gas stream and addition chamber provides NO.

[0168] Methods according to the present disclosure may include collection of blood, passage through a described depletion device, storage in an anaerobic storage bag, re-oxygenation using a device of the present disclosure, and transfusion into a patient. Methods

may further include leukoreduction steps, platelet reduction or separation steps, red blood cell editing steps, pathogen inactivation steps and volume reduction steps.

[0169] Devices of the present disclosure may be included in, and integrated into systems and methods for the preparation and extended storage of blood products including, for example, packed red blood cells (pRBC), from receipt of whole blood from a donor until transfusion to a recipient, as shown in Figure 17.

[0170] In its most general form, a system having a depletion device of the present disclosure provides for, and includes, an integrated system and method for the preparation and extended storage of red blood cells, from receipt of whole blood from a donor until transfusion to a recipient. By way of example, Figure 17 illustrates an exemplary flowchart of the components and methodology from blood collection from a blood donor **15** to transfusion to a recipient **50** using an anaerobic storage method **10** and system **25** through Pre-Storage Phase A **21**, Storage Phase B **22** in an anaerobic environment, and Post-Storage Phase C **23**. However, as understood with reference to the present disclosure, various combinations of the disclosed systems and methods are envisioned as within the scope of the disclosure, and the illustrated components and methodologies may be optionally substituted, eliminated or reordered.

[0171] By way of illustration, method **10** describes a storage system **25** that includes a depletion device **20** of the present disclosure, an anaerobic storage system **26**, and post-storage methods and systems to optimize the transfusion process to a recipient **50** and reduce morbidity associated with such transfusion. Provided for, and included in method **10** and storage system **25**, are enhancing treatments including leukoreduction **12**, editing **14**, pathogen inactivation **11** and gamma irradiation **17**. Also included and provided for are post-storage methods including gas addition using gas addition devices **46** of the present disclosure to provide oxygen **47** or oxygen **47** and nitric oxide **48** (NO) prior to transfusion to recipient **50**. Method **10** also provides for supplement addition **49** and buffer exchange **40** steps.

[0172] Again referring to the drawings, and particular to Figure 17, a method **10** describes storage system **25** from collection from a donor **15** to transfusion to a recipient **50**. System **25** shows a method that has three phases during which different sub-processes or steps may occur. The three phases are generally: Pre-Storage Phase A **21**, Storage Phase B **22** and Post-Storage Phase C **23**. As shown in Figure 17, different steps of the blood storage method **10** can occur at different phases to achieve optimal blood transfusion results as indicated by dashed

arrows. For example, gamma irradiation **17** can optionally occur during Pre-Storage Phase A **21** before depletion using a depletion device **20** of the present disclosure, during Storage Phase B **22**, during the Post-Storage Phase C **23**, during Storage Phase B **22** and a portion of Pre-Storage Phase A **21** and Post-Storage Phase C **23**, or combinations thereof, etc. Similarly, editing **14** of RBCs (*e.g.*, to remove moribund RBCs) can occur during Pre-storage Phase A **21**, during Post-storage Phase C **23**, or a combination thereof, etc. An anaerobic environment **27** has synergistic relationships with steps such as the addition of nitric oxide **48**, gamma irradiation **17** and pathogen inactivation **11**, that provide advantages to the RBCs that must occur in such anaerobic environment. Accordingly, there exist several different sequences for the blood storage processing according to the present disclosure.

[0173] Pre-storage Phase A **21** includes the time from collection from a donor **15** to storage in an anaerobic environment **27**. During Phase A **21**, whole blood **31** may be collected from a donor **15**, and the blood components, namely, plasma **33**, platelets **34** and RBCs **32** may be separated. An optional additive solution **18** may be added to the whole blood to aid in storage and/or processing, as further described herein. Processing such as pathogen inactivation **11**, leukoreduction **12** and editing **14** may occur during Pre-storage Phase A **21**. During Phase A **21**, oxygen, carbon dioxide, or oxygen and carbon dioxide are depleted using the depletion devices **20** of the present disclosure prior to Storage Phase B **22**.

[0174] Storage Phase B **22** is an anaerobic storage period, wherein anaerobic RBCs **30** are stored in an anaerobic storage environment **27**, for example anaerobic storage bag **36**. In some embodiments, the anaerobic environment **27** is maintained by an anaerobic storage bag **36** after oxygen depletion using a depletion device **20** of the present disclosure.

[0175] Post-Storage Phase C **23**, begins after storage in an anaerobic storage environment **27** but prior to transfusion to recipient **50** and may include processing such as volume reduction **41**, editing **14**, cleansing during buffer exchange **40**, the addition of either or both nitric oxide **48** and oxygen **46**, etc. In some embodiments, addition of either or both nitric oxide **48** and oxygen **46** may be accomplished using the gas addition devices **46** of the present disclosure.

[0176] Referring to the drawings and in particular to Figure 18, an exemplary anaerobic storage system **25** is shown. In certain embodiments, system **25** may be constructed so as to be disposable. Again, system **25** is an exemplary system; accordingly, different sub-processes or steps can occur at different times or during different phases as discussed above. Blood storage

system **25** includes a depletion device **20** of the present disclosure (for example, devices **100-1500**), an anaerobic blood storage bag **36** and an optional additive solution bag **250**.

Components conventionally associated with the process of blood collection are a phlebotomy needle **16**, a blood collection bag **35** containing an anti-coagulant (e.g., an additive **18**) and a bag **45** containing plasma. Tubing can connect the various components of the blood storage system **25** in various configurations (one embodiment shown). Depletion devices according to the present disclosure may include a depletion device **100, 200, 300, 400, 500, 600, 700, 800, 900, or 1000**), a gas and plasma separation device **1200 or 1300**, or a combined leukoreduction, plasma separation depletion device **1400 or 1500**. System **25** may also contain a leukoreduction filter **4000**, and a editing device **5000**, an irradiation device **6000**, a pathogen inactivation device **7000**, a volume reduction device **8000** and a gas addition device **9000**. For example a gas addition device **1600** according the present disclosure to immediately supply nitric oxide **48**, oxygen **47**, or oxygen **47** and NO **48** to the RBCs in advance of transfusion to a recipient **50**. System **25** can contain all or a combination of such devices **4000** through **9000** in varying configurations.

System **25** may also contain devices **100** through **1600** as discussed above.

[0177] Components of system **25** are connected in a conventional fashion. Tube **440** connects collection bag **35** with leukoreduction filter **400**. Tube **441** connects solution bag **250** with collection bag **35**. Tube **442** connects plasma bag **45** with collection bag **35**. Tube **443** connects leukoreduction filter **4000** with a depletion device **100** of the present disclosure. Tube **444** connects depletion device **100** with blood storage bag **2000**. Blood storage system **25** is preferably a single-use, disposable, low cost system.

[0178] System components, namely, leukoreduction filter **4000**, editing device **5000**, irradiation device **6000**, pathogen inactivation device **7000**, volume reduction device **8000** and nitric oxide device **9000**, perform various therapies for the RBCs prior to transfusion.

Depending upon the therapies, such therapies are performed on RBCs before passage through a depletion device **20** of the present disclosure, or after storage in storage bag **36**. After being depleted in a depletion device **20**, RBCs are maintained in an oxygen, carbon dioxide, or oxygen and carbon dioxide depleted environment **27** to ensure the desired results for the patient and to avoid morbidity commonly associated with transfusions using stored RBCs.

[0179] Additional non-limiting examples of blood storage systems incorporating the depletion devices and gas addition devices of the present disclosure may be found in U.S.

Application No. 13/541,554, filed July 3, 2012, entitled "System for Extended Storage of Red Blood Cells and Methods of Use," hereby incorporated by reference in its entirety.

[0180] Each periodical, patent, and other document or reference cited herein is herein incorporated by reference in its entirety.

5 [0181] Having now generally described the invention, the same will be more readily understood through reference to the following examples that are provided by way of illustration, and are not intended to be limiting of the present invention, unless specified.

Examples

Example 1: Rigid enclosure, single liquid chamber, dual depletion chamber device

10 [0182] Figures 1A, 1B and 1C depict a rigid enclosure depletion device **100** with a single liquid chamber **101** and two depletion chambers **102**. The two depletion chambers **102** are formed by rigid enclosure outer shells **103** and gas permeable barriers **107**. The single liquid chamber **101** is formed by inner shell **109** and gas permeable barriers **107** and has an inlet **104** and an outlet **105**. Depletion chambers **102** contain depletion media **106**. Gas permeable
15 barriers **107** separate the single liquid chamber **101** and two depletion chambers **102**.

[0183] As blood enters the single liquid chamber **101** through the inlet **104**, it is exposed to an oxygen depleted environment created by depletion media **106** in depletion chambers **102** where depletion media **106** is a solid O₂ and CO₂ sorbent combination. This causes the red blood cells to release oxygen and carbon dioxide into the gas depleted environment of depletion
20 chambers **102**. The oxygen and carbon dioxide diffuse through the gas permeable barriers **107**. The increase in O₂ and CO₂ gases in the gas depleted environment causes a reaction in the depletion media **106** that removes this added oxygen and carbon dioxide from the environment. Oxygen and carbon dioxide depletion media **106** are depicted as a rectangular package present in
25 depletion chambers **102**, though several packets of oxygen and carbon dioxide depletion media **106**, separate or combined, could be placed in each chamber or a single longer packet of oxygen and carbon dioxide depletion media **106** could be used.

[0184] The liquid chamber **101** contains flow control features **108** that direct the flow of liquid against the gas permeable barriers **107**. This directed flow both mixes and minimizes the distance between individual red cells and the gas permeable barriers **107**. The flow control
30 features **108** are depicted as approximately one-half the height of the blood chamber **101** (Figure

1B). This ratio may be altered for different flow rates. The number and position of flow control features **108** can also be altered to optimize the process for a specific configuration. The oxygen and carbon dioxide depletion process continues during the exposure of the liquid containing red blood cells in liquid chamber **101** until the cells and liquid are oxygen and carbon dioxide
5 depleted to the desired level and exit through outlet **105**. The degree of oxygen and carbon dioxide depletion is controlled by the height, length and width of the device, the time that the liquid is in the chamber and the flow rate through the chamber. Although depicted with the inlet **104** at the top and outlet **105** at the bottom, the orientation can be reversed to control the flow into and out of liquid chamber **101**.

10 Example 2: Rigid enclosure, dual liquid chamber, three depletion chamber device

[0185] Figures 3A, 3B and 3C depict a rigid enclosure depletion device **300** with two liquid chambers **101** and three depletion chambers **102**. The two outer depletion chambers **102** are formed by the gas barrier enclosure outer shells **103**. The inner depletion chamber **102** is formed by the enclosure shell **110**. The two liquid chambers **101** are formed by outer enclosure
15 shells **109** and have inlets **104** and outlets **105**. Depletion chambers **102** contain oxygen and carbon dioxide depletion media **106**. Gas permeable barriers **107** separate the two liquid chambers **101** and three depletion chambers **102**. As liquid enters the liquid chamber **101** through an inlet **104**, it is exposed to an oxygen and carbon dioxide depleted environment created by oxygen and carbon dioxide depletion media **106**. This causes red blood cells in the liquid to
20 release oxygen and carbon dioxide into the oxygen and carbon dioxide depleted environment. The oxygen and carbon dioxide gases diffuse through the gas permeable barriers **107**. The increase in oxygen and carbon dioxide in the gas depleted environment results in a reaction with the oxygen and carbon dioxide depletion media **106** that removes this added gas from the environment. This process continues during the exposure of the red blood cells in the liquid until
25 the cells are oxygen and carbon dioxide depleted to a desired level and exit through outlet **105**. Although depicted with an inlet **104** and an outlet **105** at the top and an inlet **104** and an outlet **105** at the bottom connected, the orientation can be reversed to control the flow into and out of liquid chambers **101**. The liquid chambers could also be connected in parallel with both inlets and both outlets at the same end of the device. A “stacked” depletion device **300** replicates all
30 the features and capabilities of depletion device **100** shown in Figures 1A, 1B and 1C. Stacking the design combined with altering the internal features and ratios of the blood chamber **109** and

the control features **108** can be continued creating as many layers as required to meet the oxygen and carbon dioxide depletion process requirements.

Example 3: Flexible enclosure, rigid liquid chamber, dual depletion chamber device.

[0186] Figures 4A-C depict flexible enclosure gas depletion device **400** having a single liquid chamber **101** and having two depletion chambers **102**. The two depletion chambers **102** are each formed by gas permeable barrier **107** and flexible shell **129**. The single liquid chamber **101** has an inlet **104** and outlet **105** in rigid inner shell **109**. Rigid inner shell **109** includes flow control features **108**. Depletion chambers **103** contain depletion media **106**.

[0187] As liquid containing red blood cells enters the single liquid chamber **101** through the inlet **104**, it is exposed to a gas depleted environment created by oxygen and carbon dioxide depletion media **106** through gas permeable barriers **107**. This causes the red blood cells to release oxygen and carbon dioxide into the gas depleted environment. Oxygen and carbon dioxide diffuse through the gas permeable barriers **107**. The increase in oxygen and carbon dioxide in the depletion chamber causes a reaction with the oxygen and carbon dioxide depletion media **106** that removes this added oxygen and carbon dioxide from the environment. Oxygen and carbon dioxide depletion media **106** is depicted in a rectangular package in the center of depletion chambers **102**. Several packets of oxygen and carbon dioxide depletion media **106** could be placed in each chamber or a single longer packet of oxygen and carbon dioxide depletion media **106** could be used. The oxygen and carbon dioxide media **106** could be included as separate packets. The configuration of the packet and the chemistry contained in the oxygen and carbon dioxide depletion media **106** could be different for each depletion chamber **102** to optimize performance. The oxygen and carbon dioxide depletion process continues during the exposure of the red blood cells in liquid chamber **101** until the red blood cells and liquid are oxygen and carbon dioxide depleted to the desired level and exit through outlet **105**. The degree of oxygen and carbon dioxide depletion is controlled by the height and length of the device, the time that the blood is in the chamber or the flow rate through the chamber and the width of the blood chamber. Although depicted with the inlet **104** at the top and outlet **105** at the bottom, the orientation can be reversed to control the flow into and out of liquid chamber **101**.

Example 4: Flexible enclosure, single liquid chamber, dual depletion chamber device.

[0188] Figure 5A, 5B and 5C depict a flexible enclosure gas depletion device **500** with a single liquid chamber **101** and two depletion chambers **102**. As depicted in Figure 5A, the

flexible enclosure may provide, but does not require, expansion or inflation of the device as liquid flows through the liquid chamber **101**. The two depletion chambers **102** are formed by the gas barrier outer films forming flexible shell **129**. The single liquid chamber **101** has an inlet **104** and an outlet **105**. Depletion chambers **102** contain oxygen and carbon dioxide depletion media **106**. Gas permeable barriers **107** separate the single liquid chamber **101** and two depletion chambers **102**.

[0189] As liquid containing red blood cells enters the single liquid chamber **101** through the inlet **104**, it is exposed to a gas depleted environment created by oxygen and carbon dioxide depletion media **106**. This causes the red blood cells to release oxygen and carbon dioxide into the gas depleted environment. Oxygen and carbon dioxide diffuse through the gas permeable barriers **107**. The increase in oxygen and carbon dioxide in the depletion chamber causes a reaction with the oxygen and carbon dioxide depletion media **106** that removes this added oxygen and carbon dioxide from the environment. Oxygen and carbon dioxide depletion media **106** is depicted in a rectangular package in the center of depletion chambers **102**. Several packets of oxygen and carbon dioxide depletion media **106** could be placed in each chamber or a single longer packet of oxygen and carbon dioxide depletion media **106** could be used. The oxygen and carbon dioxide media **106** could be included as separate packets. The configuration of the packet and the chemistry contained in the oxygen and carbon dioxide depletion media **106** could be different for each depletion chamber **102** to optimize performance. The liquid chamber **101** is depicted without flow control features **108**, though flow control features could be incorporated, for example as provided in Example 5. The oxygen and carbon dioxide depletion process continues during the exposure of the red blood cells in liquid chamber **101** until the red blood cells and liquid are oxygen and carbon dioxide depleted to the desired level and exit through outlet **105**. The degree of oxygen and carbon dioxide depletion is controlled by the height and length of the device, the time that the blood is in the chamber or the flow rate through the chamber and the width of the blood chamber. Although depicted with the inlet **104** at the top and outlet **105** at the bottom, the orientation can be reversed to control the flow into and out of liquid chamber **101**.

Example 5: Flexible enclosure, single liquid chamber, dual depletion chamber device.

[0190] Figures 6A-C depict a flexible enclosure gas depletion device **600** with a single liquid chamber **101** and two depletion chambers **102**. The two depletion chambers **102** are

formed by gas barrier outer films to form flexible shell **129**. The single liquid chamber **101** has a liquid inlet **104** and a liquid outlet **105**. Depletion chambers **102** contain oxygen and carbon dioxide depletion media **106**. Gas permeable barriers **107** separate the single liquid chamber **101** and two depletion chambers **102**.

5 **[0191]** As liquid containing red blood cells enters the single liquid chamber **101** through the inlet **104**, it is exposed to a gas depleted environment created by oxygen and carbon dioxide depletion media **106**. This causes the red blood cells to release oxygen and carbon dioxide into the gas depleted environment. Oxygen and carbon dioxide diffuse through the gas permeable barriers **107**. The increase in oxygen and carbon dioxide in the depletion chamber causes a
10 reaction with the oxygen and carbon dioxide depletion media **106** that removes this added oxygen and carbon dioxide from the environment. Oxygen and carbon dioxide depletion media **106** is provided as described above. The liquid chamber **101** is provided with an indirect path **133** for the flow of liquid produced by bonding the gas permeable barriers **107** together in a manner that would direct the flow of blood along a controlled path in the gas permeable barriers
15 **107**. This directed flow mixes and minimizes the distance between individual red blood cells and the gas permeable barriers **107**. The oxygen and carbon dioxide depletion process continues during the exposure of the red blood cells in liquid chamber **101** until the red blood cells and liquid are oxygen and carbon dioxide depleted to the desired level and exit through outlet **105**. The degree of oxygen and carbon dioxide depletion is controlled by the height and length of the
20 device, the time that the blood is in the chamber or the flow rate through the chamber and the width of the blood chamber. Although depicted with the inlet **104** at the top and outlet **105** at the bottom, the orientation can be reversed to control the flow into and out of liquid chamber **101**.

Example 6: Flexible enclosure, dual liquid chamber, triple depletion chamber device.

25 **[0192]** Figures 7A, 7B and 7C depict a flexible enclosure depletion device **700** with two liquid chambers **101** and three depletion chambers **102**. The two outer depletion chambers **102** are formed by the gas barrier outer films forming flexible shell **129**. The inner depletion chambers **102** are formed by sealing the center two gas permeable barriers **107** at the edges. The two liquid chambers **101** are formed by sealing the outer two gas permeable barriers **107** to the inner two gas permeable barriers **107** at the outer edges with inlets **104** and outlets **105**. Oxygen
30 and carbon dioxide depletion chambers **102** contain oxygen and carbon dioxide depletion media **106**. Gas permeable barriers **107** separate the two liquid chambers **101** and three depletion

chambers **102**. As liquid having red blood cells enters liquid chamber **101** through an inlet **104**, it is exposed to an oxygen and carbon dioxide depleted environment created by oxygen and carbon dioxide depletion media **106**. This causes the red blood cells to release oxygen and carbon dioxide into the oxygen and carbon dioxide depleted environment. Oxygen and carbon dioxide gases diffuse through the gas permeable barriers **107**. The increase in oxygen and carbon dioxide in the gas depleted environment causes a reaction in the oxygen and carbon dioxide depletion media **106** that removes these added gases from the environment. Liquid chambers **101** are depicted without flow control features. Flow control features can be formed by bonding the gas permeable barriers **107**, for example as illustrated in Figures 6A-C. The depletion process continues during the exposure of the red blood cells until the cells are oxygen and carbon dioxide depleted to a desired level and exit through outlet **105**. Although depicted with the inlet **104** and outlet **105** at the top and the inlet **104** and outlet **105** at the bottom connected, the orientation can be reversed to control the flow into and out of liquid chambers **101**. The liquid chambers **101** could also be connected in parallel with both inlets and both outlets at the same end of the device.

[0193] This stack design replicates all the features and capabilities of depletion device **500** shown in Figures 3A, 3B and 3C. Similar features and capabilities of depletion device **600** can be incorporated into a stacked design of device **700**. Stacking the design combined with altering the internal features can create as many layers as required to meet the oxygen and carbon dioxide depletion process requirements.

Example 7. Flexible enclosure, single liquid chamber, dual depletion chamber device.

[0194] Figures 8A, 8B and 8C depict a rigid enclosure depletion device **800** with a single liquid chamber **101** and two depletion chambers **115**. The two depletion chambers **115** are formed by rigid enclosure outer shells **103** that are gas impermeable. The single liquid chamber **101** is formed by inner shell **109** and has an inlet **104** and an outlet **105**. Oxygen and carbon dioxide depletion chambers **115** are formed by gas barrier outer enclosure shells **103** having gas inlets **111** and gas outlets **112** through which depletion gas **114** enters and exits the device and gas permeable barriers **107**. Gas permeable barriers **107** separate the single liquid chamber **101** and two depletion chambers **115**.

[0195] As blood enters the single liquid chamber **101** through the inlet **104**, it is exposed to a gas depleted environment created by a depletion gas **114** entering the gas inlets **111**. The

depletion gas **114** may be either oxygen free or oxygen and carbon dioxide free. An oxygen and carbon dioxide free depletion gas **114** causes the red blood cells to release oxygen and carbon dioxide into the oxygen and carbon dioxide depleted environment. The oxygen and carbon dioxide gases diffuse through the gas permeable barriers **107**. The increased oxygen and carbon dioxide in the depletion environment mixes with the depletion gas **114** and exits through gas outlet **112**. The flow of gas removes the added oxygen and carbon dioxide from the environment of depletion chamber **102**. Although depicted with the gas inlets **111** at the top and gas outlets **112** at the bottom, the orientation can be reversed to control the flow into and out of oxygen depleted chambers **115**. Oxygen free or oxygen and carbon dioxide depletion gases are not depicted. Several gases including, but not limited to, argon, helium, and nitrogen are used. The configuration of the gas and the flow rate may be different for each depletion chamber **102** to optimize performance. Depletion chambers **115** formed by gas barrier outer shells **103** contain gas flow control features **113**. These flow control features **113** are depicted as two horizontal bars. These features increase the mixing of the released oxygen with the depletion gas **114**. Different configurations can be used depending on the gas and flow rate selected.

[0196] The liquid chamber **101** contains flow control features **108** as described above. The gas depletion process continues during the exposure of the red blood cells in liquid chamber **101** until the cells are gas depleted to the desired level and exit through outlet **105**. The degree of gas depletion is controlled by the height and length of the device, the time that the liquid containing red blood cells is in the chamber, the flow rate through the chamber and the width of the liquid chamber. Although depicted with the inlet **104** at the top and outlet **105** at the bottom, the orientation can be reversed to control the flow into and out of liquid chamber **101**.

Example 8. Rigid enclosure, dual liquid chamber, triple gas depletion chamber device.

[0197] Figures 9A, 9B and 9C depict a rigid enclosure depletion device **900** with two liquid chambers **101** and gas depletion chambers **115**. The two gas depletion chambers **115** are formed by gas barrier outer shells **103**. The two liquid chambers **101** are formed by inner shells **109** and have inlets **104** and outlets **105**. The two outer gas depletion chambers **115** formed by gas barrier outer shells **103** have gas inlets **111** and gas outlets **112**. The inner depletion chamber **115** is formed by the gas barrier enclosure shell **110**. Gas permeable barriers **107** separate the two liquid chambers **101** and three gas depletion chambers **115**.

[0198] As liquid containing red blood cells enters the liquid chambers **101** through an inlet **104**, it is exposed to a gas depleted environment created by oxygen free or oxygen and carbon dioxide free gas entering the gas inlets **111** as provided for device **800** above. Although depicted with an inlet **104** and an outlet **105** at the top and an inlet **104** and an outlet **105** at the bottom connected, the orientation can be reversed to control the flow into and out of liquid chambers **101**. A depletion device **900** provides for the serial depletion of a liquid flowing through the device. Additional gas depletion chambers **115** and liquid chambers **101** can readily be added. The chambers could also be connected in parallel with both inlets and both outlets at the same end of the device.

[0199] The gas depletion process continues during the exposure of the red blood cells in liquid chamber **101** until the cells are gas depleted to the desired level and exit through outlets **105**. The degree of gas depletion is controlled by the height and length of the device, the time that the liquid is in the chamber or the flow rate through the chamber and the width of the liquid chamber.

Example 9. Rigid enclosure, dual liquid chamber, triple gas depletion chamber device.

[0200] Figures 10A, 10B and 10C depict a rigid enclosure depletion device **1000** with two liquid chambers **101** and gas depletion chambers **115** similar to depletion device **900** above except that the red blood cell containing fluid flows in parallel rather than in series. The two gas depletion chambers **115** are formed by gas barrier outer shells **103**. The two liquid chambers **101** are formed by inner shells **109** and have inlets **104** and outlets **105**. In device **1000**, the flow of liquid is split to two or more inlets **104** by splitter **130** and the flow of depleted liquid is combined after exiting from outlet **105** by joiner **131**. Operation of the devices is as described above in Example 8.

Example 10. Rigid enclosure, single liquid chamber, single depletion chamber plasma separation device.

[0201] Figures 12A, 12B and 12C depict a rigid enclosure depletion device **1200** with a single liquid chamber **101**, a depletion chamber **102**, and a plasma/platelet chamber **127**. The depletion chamber **102** is formed by rigid enclosure outer shells **103** and a gas permeable barrier **107**. The single liquid chamber **101** is formed by inner shell **109** and gas permeable barrier **107** and plasma porous hydrophobic membrane **124**. Depletion device **1200** has an inlet **104** and an outlet **105**. Depletion chamber **102** contains depletion media **106**. Gas permeable barrier **107**

separates the single liquid chamber **101** and depletion chamber **102**. Depletion device **1200** also has a plasma chamber **127** formed from plasma outer shell **119** and plasma porous hydrophilic membrane **124** and an anaerobic plasma port **116**.

[0202] As blood enters the single liquid chamber **101** through the inlet **104**, it is exposed
5 to an oxygen depleted environment created by depletion media **106** in depletion chamber **102**
where depletion media **106** is a solid O₂ and CO₂ sorbent combination. This causes the red blood
cells to release oxygen and carbon dioxide into the gas depleted environment of depletion
chambers **102**, resulting in the diffusion of oxygen and carbon dioxide from the liquid chamber
101 through the gas permeable barrier **107**. Gas depletion proceeds as for the devices described
10 in the examples above. Also as provided in the examples above, the liquid chamber **101** contains
flow control features **108**.

[0203] The liquid chamber **101** further contains a plasma porous hydrophilic membrane
124 separating liquid chamber **101** from plasma chamber **127**. Anaerobic plasma passes through
the plasma porous hydrophilic membrane **118** into plasma chamber **127** and the anaerobic
15 plasma **120** exits through anaerobic plasma port **116**. Flow of anaerobic plasma through plasma
porous hydrophilic membrane **127** and into anaerobic plasma chamber **127** is controlled by a
pressure differential between liquid chamber **101** and plasma chamber **127**. Increased pressure
in liquid chamber **101** relative to the pressure of plasma chamber **117** results in an increase in
plasma flow through plasma porous hydrophilic membrane **124** and into anaerobic plasma
20 chamber **127**.

Example 11: Rigid enclosure, single liquid chamber, dual depletion chamber, plasma
separation device.

[0204] Figures 13A, 13B and 13C depict a rigid enclosure depletion device **1300** with a
single liquid chamber **101** and two depletion chambers **102** and **122**. A first depletion chamber
25 **102** is formed by rigid enclosure outer shells **103** and a gas permeable barrier **107**. A second
depletion chamber **122** is formed by outer shell **103** and a gas permeable barrier **107**. The single
liquid chamber **101** is formed by inner shell **109**, gas permeable barrier **107**, and plasma porous
hydrophobic membrane **124**. Depletion device **1300** and has an inlet **104** and an outlet **105**.
Depletion chamber **102** and depletion chamber **122** contain depletion media **106**. A gas
30 permeable barrier **107** separates a single liquid chamber **101** and depletion chamber **102** and a
gas permeable barrier **107** separates plasma chamber **117** from depletion chamber **122**.

Depletion device **1300** also has a plasma chamber **117** formed from plasma outer shell **119**, plasma porous hydrophilic membrane **124**, and gas permeable barrier **107**. Plasma chamber **117** has anaerobic plasma port **116**.

5 [0205] As blood enters the single liquid chamber **101** through the inlet **104**, it is exposed to an oxygen depleted environment created by depletion media **106** in depletion chamber **102** where depletion media **106** is a solid O₂ and CO₂ sorbent combination. Gas depletion proceeds as provided in the examples above.

10 [0206] The liquid chamber **101** further contains a plasma porous hydrophilic membrane **124** separating liquid chamber **101** from plasma chamber **117**. Gas depleted plasma passes through the plasma porous hydrophilic membrane **124** into anaerobic plasma chamber **117** and the anaerobic plasma **120** exits through anaerobic plasma port **116**. The plasma in plasma chamber **117** is separated from a second depletion chamber **122** which provides for further removal of O₂ and CO₂ (depending on depletion media **106**). Flow of anaerobic plasma through plasma porous hydrophilic membrane **124** and into anaerobic plasma chamber **117** is controlled
15 by a pressure differential between liquid chamber **101** and plasma chamber **117**. Increased pressure in liquid chamber **101** relative to the pressure of plasma chamber **117** results in an increase in plasma flow through plasma porous hydrophilic membrane **124** and into anaerobic plasma chamber **117**.

Example 12: Combined leukoreduction and gas depletion device.

20 [0207] Figures 14A, 14B and 14C depict a combination depletion device **1400** having a leukoreduction media **123**, a leukoreduction chamber **125**, a leukoreduced fluid chamber **132**, a liquid chamber **101** and two depletion chambers **102**. The combination depletion device **1400** includes a liquid inlet **104** and liquid outlet **105**. As provided in the examples above, depletion chambers **102** have depletion media **106** to provide for an oxygen free and carbon dioxide free
25 environment.

[0208] As plasma reduced blood enters through liquid inlet **104**, the fluid passes through leukoreduction media **123** which binds to or adsorbs white blood cells present in the blood. Upon passing through leukoreduction media **123**, the fluid enters leukoreduction chamber **125** and flows to depletion chamber **102** having flow control features **108**. As provided in the
30 examples above, the blood is depleted of oxygen and carbon dioxide and flows out through liquid outlet **105**.

[0209] As shown in Figure 14A, leukoreduction media **123** is provided in a membrane form. In alternate configurations, the leukoreduction media **123** may be provided as a matrix through which the liquid flows. In this alternate configuration, leukoreduction chamber **123** and leukoreduced fluid chamber **132** may be combined and filled with a leukoreduction media **123** matrix.

Example 13: Combined leukoreduction, gas depletion, and plasma separation device.

[0210] Figures 15A, 15B and 15C depict a combination depletion device **1500** having a leukoreduction media **123**, a leukoreduction chamber **125**, a plasma separation chamber **126**, a liquid chamber **101** and two depletion chambers **102**. The combination depletion device **1500** includes a liquid inlet **104** and liquid outlets **105** and **106**. The depletion chambers **102** having depletion media **106** and flow control features **108** are as provided in the examples above.

[0211] As whole blood enters through liquid inlet **104**, the fluid passes through leukoreduction media **123** which binds to, or adsorbs, white blood cells present in the blood. Upon passing through leukoreduction media **123**, the fluid enters plasma separation chamber **126**. As provided above, leukoreduction media **123** may be provided either as a membrane or a matrix of leukoreduction media. Plasma and platelets flow through the plasma porous hydrophobic membrane **124** into plasma/platelet chamber **127**. The plasma and platelets flow from the chamber through **116** to a plasma and platelet collection bag (not shown). The now leukocyte/plasma/platelet depleted fluid having red blood cells flows into depletion chamber **102** and is depleted of oxygen and carbon dioxide in the manner described above. Anaerobic red blood cells flow out through liquid outlet **105** and are collected and stored in an anaerobic storage bag.

Example 14: Reoxygenation device.

[0212] Figures 16A, 16B and 16C depict a reoxygenation device **1600** according to the present disclosure having a gas addition chamber **134**, separated by gas permeable barrier **107**, and liquid chamber **101** formed by two gas permeable barriers **107**.

[0213] An oxygen (or oxygen and carbon dioxide) depleted blood product enters through liquid inlet **104** and passes through liquid chamber **102** where it is supplied with oxygen through gas permeable barriers **107**. As shown, ambient air is provided through gas addition ports **128**. Oxygen diffuses from gas addition chambers **134**, through gas permeable barriers **107** and is absorbed by the hemoglobin in the red blood cells. In some embodiments, addition ports **128**

provide for an oxygen rich gas source to flow into the gas addition chamber **134**. Any suitable gas may be provided to a gas addition device through addition port **128** including ambient air, pure oxygen and mixtures of oxygen and carbon dioxide and may further comprise NO, either together with O₂ or provided separately.

5 Example 15: Depletion of oxygen in a red blood cell suspension using a single cassette configuration.

[0214] Oxygen is depleted in a red blood cell suspension using a device having a flexible enclosure, single liquid chamber, and dual depletion chamber (single cassette configuration). Deoxygenation of a red blood suspension is tested with a device of the present disclosure
10 constructed from acrylic blocks machined with a sinuous path profile design described in Figures 6A, 6B, and 6C. Gas permeable barrier **107** is provided by a hydrophobic membrane (GVSP22205, Millipore, Billerica, MA). The membrane is attached to the sinuous path using Arrow AP10-4 all-purpose hot melt glue (Arrow Fastener Co., Saddle Brook, NJ). Depletion media **106** is provided by a flushing gas (100% N₂). Table 1 summarizes the path geometries of
15 three prototype devices tested. All devices have the same path length of 2235 mm and exposed surface area of 90 cm².

[0215] Two flow-through cell oxygen sensors (“cell”), are placed in series with the device, one upstream of inlet **104** and another downstream of outlet **105**. The cell sensors comprise a PreSens Fibox 3 trace device running PreSens Fibox 3 trace PSt6 software
20 (PST6v701) and an pST3 oxygen probe for in-line measurement (PreSens - Precision Sensing GmbH). Two dipping probe oxygen sensors (“probe”) are provided in series with liquid chamber **101** inside flexible shell **129**, one directly downstream of inlet **104** and another directly upstream of outlet **105**. The probe sensors comprise a PreSens OXY-4 mini device running
25 PreSens OXY-4 mini software (OXY4v2_30fb) and a PSt6 oxygen dipping probe sensor (PreSens - Precision Sensing GmbH). These sensors monitor partial pressures of oxygen in the fluid suspension having red blood cells at different positions along the flow path.

[0216] In this example, a red blood suspension flows through the sensor-liquid chamber assembly once. Table 2 summarizes the results of the deoxygenation process in the different prototype devices. All tests are performed at room temperature. The average partial pressure of
30 oxygen in the red blood suspension measured by an inlet sensor is pO_{2 in}. The average partial pressure of oxygen in the red blood suspension measured by an outlet sensor is pO_{2 out}. The

change in oxygen level (ΔpO_2) is calculated by taking the difference between $pO_{2\text{ in}}$ and $pO_{2\text{ out}}$. The percentage of oxygen reduction ($\%O_2$ reduction) is calculated by dividing ΔpO_2 by $pO_{2\text{ in}}$.

[0217] The exposed surface area to path volume ratio is observed to affect the efficiency of oxygen reduction. At the flow rate of 1 ml/min, prototype device A provides the highest percentage of oxygen reduction out of the three devices. An effect of flow rates on the efficiency of oxygen depletion is also observed in prototype device B. Out of three flow rates (1 ml/min, 1.2 ml/min, and 1.4 ml/min), the highest percentage of oxygen reduction is observed at 1 ml/min.

[0218] Probe sensors consistently measure higher percentage of oxygen reduction compared to cell sensors plausibly due to their relative positioning to the flexible shell 129 or possibly due to non-homogeneity of the fluid.

Table 1: Flow Path Geometries

Device ID	Path Depth (mm)	Path Length (mm)	Path Volume (ml)	Exposed Surface Area (cm ²)
A	0.5	2235	4.5	90
B	1	2235	8.9	90
C	2	2235	17.9	90

Table 2: Measurements of Oxygen Level

Device ID	Sensor Type	Flow Rate (ml/min)	Processing Time (min)	$pO_{2\text{ in}}$ (Torr)	$pO_{2\text{ out}}$ (Torr)	ΔpO_2 (Torr)	$\%O_2$ Reduction
A	Cell	1	4.5	12.0	2.7	9.3	78
A	Probe	1	4.5	11.2	1.5	9.7	87
B	Probe	1	8.9	26	5	21	81
B	Cell	1.2	7.4	18	10	8	44
B	Probe	1.2	7.4	18	4	14	78
B	Cell	4.1	2.2	18	9	9	50
B	Probe	4.1	2.2	17	4	13	76
C	Probe	1	17.9	20	12	8	40

Example 16: Depletion of oxygen in a red blood cell suspension using multiple devices connected in series.

[0219] Devices having path geometries described in Table 1 are constructed as described in Example 15. Three devices having the same path depth are connected in series to produce a test set. Table 3 summarizes the overall path geometries for each test set. Each set of devices have in total the same path length of 6705 mm and exposed surface area of 269 cm².

[0220] Two dipping probe oxygen sensors (“probe”) are provided in series with liquid chamber 101 inside flexible shell 129 of a first device in the series, one directly downstream of inlet 104 and another directly upstream of outlet 105. The probe sensors are as described above in example 15. Additionally, two dipping probe oxygen sensors (“probe”) are provided in series
 5 with liquid chamber 101 inside flexible shell 129 of a third device in the series, one directly downstream of inlet 104 and another directly upstream of outlet 105. These sensors monitor partial pressures of oxygen in blood at different positions along the flow path.

[0221] Oxygen saturation levels and partial pressures of oxygen in a red blood cell suspension are also tested both pre- and post- processing. An aliquot of the red blood cell
 10 suspension is taken via a syringe before and after processing and is analyzed in an oxygen analyzer (“Nova COOX”; Nova Analytical Systems, Niagara Falls, NY).

[0222] In this example, a red blood cell suspension flows through a test set once. Table 4 summarizes the results of the deoxygenation process in the different test sets. All tests are performed at temperatures between 22.0 to 23.6°C. The average partial pressure of oxygen in
 15 blood measured by the inlet sensor in a first device of the test set is $pO_{2\ d1in}$. The average partial pressure of oxygen in blood measured by the outlet sensor in a third device of the test set is $pO_{2\ d3out}$. The change in oxygen level (ΔpO_2) is calculated by taking the difference between $pO_{2\ d1in}$ and $pO_{2\ d3out}$. The percentage of oxygen reduction (% O_2 reduction) is calculated by dividing ΔpO_2 by $pO_{2\ d1in}$. Table 5 compares the measured % SO_2 at 37°C with calculated % SO_2
 20 values based on the pO_2 measurements at both 23°C and 37°C. The conversion calculation is made based on the Hill Equation:

$$\%SO_2 = \frac{(pO_2)^n}{(pO_2)^n + (P_{50})^n} \times 100\%$$

where $n=2.7$ represents the cooperativity of oxygen binding to hemoglobin, and P_{50} represents the partial pressure at which hemoglobin is half-saturated at either 23°C or 37°C. The measured
 25 or calculated oxygen saturation of the red blood cell suspension before and after the deoxygenation are % $SO_{2\ in}$ and % $SO_{2\ out}$, respectively.

[0223] At a flow rate of 1.10 ml/min, a test set comprising three prototype B devices provides the highest percentage of oxygen reduction out of the three sets, achieving 91.5% oxygen reduction. Slower flow rates are consistently observed to result in a greater percentage
 30 oxygen reduction compared to faster flow rates in all test sets. At a flow rate of 1.10 ml/min, a

red blood cell suspension sample that is processed with a test set comprising three prototype A devices is measured to have a 9.3% reduction in the saturated oxygen level at 37°C using the Nova COOX system. However, the same blood sample is calculated to exhibit a 42.9% reduction in its oxygen saturation level based on the pO₂ measurements produced from the same system at 37°C. Not to be limited by theory, this may suggest that the cooperativity or the P₅₀ value in the Hill Equation model may not be optimized to reflect experimental results. Another discrepancy is observed between the post-processing pO₂ measurements made by the in-line probe sensor and the Nova COOX system. Not to be limited by theory, this may suggest that the red blood cell suspension sample aliquot is being re-oxygenated quickly during its transfer to the Nova COOX system.

Table 3: Flow Path Geometries for 3 Devices in Series

Set ID	Path Depth (mm)	Path Length (mm)	Path Volume (ml)	Exposed Surface Area (cm ²)
A	0.5	6705	13.4	269
B	1	6705	26.8	269
C	2	6705	53.7	269

Table 4: Measurements of Oxygen Level

Set ID	Flow Rate (ml/min)	Processing Time (min)	pO _{2 d1in} (Torr)	pO _{2 d1out} (Torr)	pO _{2 d3in} (Torr)	pO _{2 d3out} (Torr)	ΔpO ₂ (Torr)	%O ₂ Reduction
A	1.10	14.90	15.70	4.40	7.70	1.50	14.20	90.4
A	2.16	7.59	14.70	4.28	6.28	4.19	10.51	71.5
B	1.10	29.64	18.30	8.08	9.10	1.56	16.74	91.5
B	3.98	8.19	20.87	12.73	8.31	8.05	12.82	61.4
B	4.50	7.24	15.60	12.14	9.12	8.61	6.99	44.8
C	1.03	57.77	18.64	8.50	10.91	7.14	11.50	61.7
C	2.10	28.33	18.05	8.71	11.24	7.73	10.32	57.2

Table 5: Comparison of pO₂ and SO₂ Measurements in Set A at 1.1 ml/min

Measurement System	Test Temp. (°C)	Measured		Calculated from pO ₂		Measured	
		pO _{2 d1in} (Torr)	pO _{2 d3out} (Torr)	%SO _{2 in}	%SO _{2 out}	%SO _{2 in}	%SO _{2 out}
Probe	23	15.70	1.50	64.9**	0.3	-	-
Nova COOX	37	15.60	9.0	73.4**	30.5	51.5	42.2

Example 17: Depletion of oxygen in a red blood cell suspension by re-circulation in a single device.

[0224] Only prototype device B is tested in this example. The device is constructed as described in Example 15. The path geometry of the device is summarized in Table 1. The sensors are arranged as described in Example 15. The oxygen saturation levels are measured as described in Example 16.

[0225] In this example, a red blood cell suspension is re-circulated through the sensor-liquid chamber assembly for at least three passes. These devices are also tested in multiple orientations and gravity feed methods. Table 6 summarizes the results of the deoxygenation process at different flow rates and re-circulation cycles. All tests are performed at temperatures between 23.6 to 25.0°C. The average partial pressure of oxygen in blood measured by an inlet sensor during a single pass is $pO_{2\text{ in}}$. The average partial pressure of oxygen in blood measured by an outlet sensor during a single pass is $pO_{2\text{ out}}$. The change in oxygen level in a single pass (ΔpO_2) is the calculated difference between $pO_{2\text{ in}}$ and $pO_{2\text{ out}}$ from the same pass measured for each type of sensors. The percentage of oxygen reduction in a single pass (% O_2 reduction (one pass)) is calculated by dividing ΔpO_2 by $pO_{2\text{ in}}$ from the same pass for each type of sensors. The overall percentage of oxygen reduction (overall % O_2 reduction (from start)) is calculated by dividing the difference between $pO_{2\text{ in}}$ of the first pass and $pO_{2\text{ out}}$ in the current pass by $pO_{2\text{ in}}$ from the first pass for each type of sensors. The oxygen saturation of the red blood cell suspension before and after the deoxygenation are % $SO_{2\text{ in}}$ at 37°C and % $SO_{2\text{ out}}$ at 37°C, respectively.

[0226] The flow rate affects the number of passes required to reduce oxygen down to a desired level. To achieve the same overall percentage oxygen reduction, it takes five passes at 8.4 ml/min compared to three passes at 5.1 ml/min. On the return pass through the device, the starting pO_2 level is higher than when the sample exited the device on the prior pass. Not to be limited by theory, this suggests that oxygen reduction in RBCs is not homogenous and diffusion from the RBC to the surrounding fluid takes place over time scales that are longer than the time necessary to remove the oxygen from the surrounding fluid. Alternatively, devices such as those Figures 3, 8, 9, 10, 13, and 15 may eliminate oxygen increases.

[0227] The observations of up to 94% reduction in the pO_2 levels suggests that the devices are effective in removing oxygen from red blood cell containing samples. The

unchanged oxygen saturation levels observed in this Example demonstrate that deoxygenated red blood cell containing blood samples can be rapidly re-oxygenated upon removal from an anaerobic environment. Not to be limited by theory, this suggests that extra care needs to be taken when measuring SO_2 in the set up disclosed herein, given that hemoglobin has a very high
5 affinity to oxygen. Such observations also support the understanding that a longer processing time is required for deoxygenation compared to re-oxygenation.

Table 6: Measurements of Oxygen Level

Test No.	Flow Rate (ml/min)	Processing Time (min)	Pass No.	pO ₂ in (Test)		pO ₂ out (Test)		ΔpO ₂ (Test)		%O ₂ Reduction (one pass)		Overall %O ₂ Reduction (from start)		%SO ₂ in at 37°C	%SO ₂ out at 37°C
				Cell	Probe	Cell	Probe	Cell	Probe	Cell	Probe	Cell	Probe		
lane 48	5.1	13	1	94.5	96.6	10.0	19.2	75.3	86.6	80	90	80	90	95.9	98.6
			2	62.7	60.6	18.2	17.0	45.7	42.4	73	70	82	81	98.6	98.1
			3	55.2	58.7	5.8	11.9	43.3	52.9	78	90	87	94	98.1	97.6
lane 64	8.4	10	1	97.9	101.8	21.1	24.2	73.7	80.7	75	79	75	79	98.8	98.2
			2	60.5	58.5	14.8	16.0	44.5	43.7	74	75	85	85	98.2	97.6
			3	48.5	49.3	14.0	15.0	33.5	35.3	69	72	85	86	97.6	97.3
lane 89	5.1	13	4	36.8	35.4	10.7	16.0	20.8	24.7	57	70	84	89	97.3	98.0
			5	31.3	33.3	7.9	14.4	16.9	25.4	54	76	85	92	98.0	97.3
			1	144.0	162.3	24.2	24.2	119.8	138.1	83	85	83	85	98.2	99.3
lane 89	5.1	13	2	82.5	82.6	12.8	18.9	63.6	69.8	77	85	87	92	99.3	99.0
			3	63.2	64.9	17.0	12.8	50.4	47.9	80	74	91	90	99.0	98.8

CLAIMS

What is claimed is:

1. A depletion device for removing a gas from a liquid comprising:
 - a. an enclosure;
 - 5 b. one or more liquid chambers;
 - c. one or more depletion chambers;
 - d. at least one gas permeable barrier separating at least one of said one or more liquid chambers from said one or more depletion chambers;
 - e. at least one liquid inlet; and
 - 10 f. at least one liquid outlet.
2. The depletion device of claim 1, wherein said gas permeable barrier is permeable to a gas selected from the group consisting of oxygen, carbon dioxide, and combinations thereof.
3. The depletion device of claim 0, wherein said gas is oxygen and carbon dioxide.
4. The depletion device of claim 1, wherein said one or more liquid chambers further comprise
15 one or more flow control features.
5. The depletion device of claim 1, wherein said at least one gas permeable barrier is a membrane comprising a polyolefin, polytetrafluoroethylene (PTFE), polyvinylidene mono- or di- fluoride (PVDF), a polysulfone, a silicone, an epoxy, a polyester membrane polyethylene, or a ceramic.
- 20 6. The depletion device of claim 5, wherein said at least one gas permeable barrier is a hydrophobic porous structure.
7. The depletion device of claim 5, wherein said gas permeable barrier comprises at least one blood-compatible surface.
8. The depletion device of claim 1, wherein said one or more liquid chambers are separated
25 from said one or more depletion chambers by more than one gas permeable barriers.

9. The depletion device of claim 1, wherein said one or more flow control features mix a liquid that enters through said at least one liquid inlet, flows through said one or more liquid chambers and exits through said at least one liquid outlet.
10. The depletion device of claim 1, wherein said liquid is a blood product selected from the
5 group consisting of whole blood, leukocyte depleted blood, leukocyte and platelet depleted blood, a red blood cell suspension, and plasma.
11. The depletion device of claim 1, wherein said enclosure is cuboid having a height, length and width and said one or more liquid chambers are cuboid having a length, width and height.
12. The depletion device of claim 11, wherein said one or more liquid chambers further comprise
10 one or more flow control features.
13. The depletion device of claim 12, wherein said one or more flow control features are half the height of said one or more liquid chambers and are the width of said one or more liquid chambers.
14. The depletion device of claim 1, wherein said one or more depletion chambers further
15 comprise at least one gas inlet and at least one gas outlet in liquid communication with said one or more depletion chambers.
15. The depletion device of claim 14, wherein said depletion chambers further comprise one or more gas flow control features.
16. The depletion device of claim 1, wherein said one or more depletion chambers have a length,
20 width and height.
17. The depletion device of claim 14, wherein a depletion gas flows into said at least one gas inlet, through said one or more depletion chambers and out through said one or more gas outlets.
18. The depletion device of claim 17, wherein said depletion gas is selected from the group
25 consisting of argon, helium, nitrogen, argon/carbon dioxide, nitrogen/carbon dioxide, and combinations thereof.

19. The depletion device of claim 1, wherein said one or more liquid chambers is selected from the group consisting of one liquid chamber, two liquid chambers, three liquid chambers, four liquid chambers and five liquid chambers.
20. The depletion device of claim 1, wherein said one or more depletion chambers is selected
5 from the group consisting of one depletion chamber, two depletion chambers, three depletion chambers, four depletion chambers, and five depletion chambers.
21. The depletion device of claim 1, wherein said one or more liquid chambers and said one or more depletion chambers alternate in a stacked configuration and said liquid chambers are in liquid communication with each other.
- 10 22. The depletion device of claim 1, wherein said one or more depletion chambers contain a depletion material selected from the group consisting of an oxygen depletion media, a carbon dioxide depletion media, and combinations thereof.
23. The depletion device of claim 22, wherein said depletion material is held in one or more packets.
- 15 24. The depletion device of claim 22, wherein said depletion material is selected from the group consisting of a gel, a solid, a gas, and combinations thereof.
25. The depletion device of claim 1, wherein said enclosure is prepared of a material selected from the group consisting of a rigid material, a flexible material, an elastic material, and combinations thereof.
- 20 26. The depletion device of claim 1, wherein said liquid chamber is prepared of a gas barrier material selected from the group consisting of a rigid material, a flexible material, an elastic material, and combinations thereof.
27. The depletion device of claim 1, wherein said one or more liquid chambers comprises at least one gas permeable barrier.

28. The depletion device of claim 1, wherein said depletion chamber is prepared of a material selected from the group consisting of a rigid material, a flexible material, an elastic material, and combinations thereof.
29. The depletion device of claim 1, wherein said depletion chamber comprises at least one gas permeable material in contacting said liquid chamber.
30. The depletion device of claim 1, further comprising a leukocyte reduction device.
31. The depletion device of claim 1, further comprising a platelet separation device.
32. The depletion device of claim 1, further comprising a red blood cell editing device.
33. The depletion device of claim 1, further comprising an oxygen and carbon dioxide impermeable blood storage device connected to said liquid outlet.
34. The depletion device of claim 33, wherein said oxygen and carbon dioxide impermeable blood storage device further comprises an oxygen and carbon dioxide scavenger.
35. A gas addition device comprising:
- a. an enclosure;
 - b. one or more liquid chambers;
 - c. one or more gas addition chambers;
 - d. at least one gas permeable barrier separating at least one of said one or more liquid chambers from said one or more gas addition chambers;
 - e. at least one liquid inlet; and
 - f. at least one liquid outlet.
36. The gas addition device of claim 35, wherein said one or more liquid chambers further comprise one or more flow control features.
37. The gas addition device of claim 35, wherein said gas permeable barrier is a membrane comprising a polyolefin, polytetrafluoroethylene (PTFE), polyvinylidene mono- or di-fluoride (PVDF), a polysulfone, a silicone, an epoxy, a polyester membrane, or a ceramic.

38. The gas addition device of claim 37, wherein said gas permeable barrier is a hydrophobic porous structure.
39. The gas addition device of claim 35, wherein said one or more liquid chambers are separated from said one or more gas addition chambers by more than one gas permeable barrier.
- 5 40. The gas addition device of claim 35, wherein said enclosure is prepared of a material selected from the group consisting of a rigid material, a flexible material, an elastic material, and combinations thereof.
41. The gas addition device of claim 35, wherein said liquid chamber is prepared of a material selected from the group consisting of a rigid material, a flexible material, an elastic material,
10 and combinations thereof.
42. The gas addition device of claim 35, wherein said gas addition chamber is prepared of a material selected from the group consisting of a rigid material, a flexible material, an elastic material, and combinations thereof.
43. The gas addition device of claim 35, wherein said one or more flow control features mix a
15 liquid that enters through said at least one liquid inlet, flows through said one or more liquid chambers and exits through said at least one liquid outlet.
44. The gas addition device of claim 35, wherein said liquid is a blood product selected from the group consisting of whole blood, leukocyte depleted blood, leukocyte and platelet depleted blood, a red blood cell suspension, oxygen and carbon dioxide depleted red blood cells,
20 oxygen depleted red blood cells, and plasma.
45. The gas addition device of claim 35, wherein said enclosure is cuboid having a length, width and height, and said one or more liquid chambers are cuboid having a length, width, and height.
46. The gas addition device of claim 45, wherein said one or more liquid chambers further
25 comprise one or more flow control features.

47. The gas addition device of claim 46, wherein said one or more flow control features are half the height of said one or more liquid chambers and are the width of said one or more liquid chambers.
48. The gas addition device of claim 35, wherein said one or more gas addition chambers further
5 comprise at least one gas inlet and at least one gas outlet in liquid communication with said one or more gas addition chambers.
49. The gas addition device of claim 48, wherein said gas addition chambers further comprise one or more gas flow control features.
50. The gas addition device of claim 35, wherein said one or more gas addition chambers are
10 cuboid having a length, width and height.
51. The gas addition depletion device of claim 48, wherein an addition gas flows into said at least one gas inlet, through said one or more depletion chambers and out through said one or more gas outlets.
52. The gas addition device of claim 51, wherein said addition gas is selected from the group
15 consisting of pure oxygen, air, carbon dioxide, nitrous oxide and combinations thereof.
53. The gas addition device of claim 35, wherein said one or more liquid chambers is selected from the group consisting of one liquid chamber, two liquid chambers, three liquid chambers, four liquid chambers, five liquid chambers, and more than five liquid chambers.
54. The gas addition device of claim 35, wherein said one or more gas addition chambers is
20 selected from the group consisting of one gas addition chamber, two gas addition chambers, three gas addition chambers, four gas addition chambers, five gas addition chambers, and more than five gas addition chambers.
55. The gas addition device of claim 35, wherein said one or more liquid chambers and said one or more gas addition chambers alternate in a stacked configuration and said liquid chambers
25 are in liquid communication with each other.

56. A method of depleting a gas from a liquid comprising flowing a liquid through a device according to claim 1 to prepare a gas depleted liquid.
57. The method of claim 56, wherein said liquid is a blood product selected from the group consisting of whole blood, leukocyte depleted blood, leukocyte and platelet depleted blood, a red blood cell suspension, and plasma.
58. The method of claim 56, wherein said gas is selected from the group consisting of oxygen, carbon dioxide, and combinations thereof.
59. The method of claim 58, wherein said gas is oxygen and carbon dioxide.
60. The method of claim 57, further comprising flowing said blood product through a leukocyte reduction device to prepare a gas depleted and leukocyte reduced blood product.
61. The method of claim 57, further comprising removing platelets from said blood product or said gas depleted blood product.
62. The method of claim 57, wherein said whole blood further comprises an anticoagulant and an additive solution.
63. The method of claim 57, wherein said gas depleted blood product has a hemoglobin oxygen saturation of less than 10%, of less than 5%, of less than 2.5%, or less than 1%.
64. A method of preparing a blood product for transfusion comprising flowing a blood product liquid through a device according to claim 35 to prepare a blood product having an increased level of gas.
65. The method of claim 64, wherein said blood product is selected from the group consisting of whole blood, leukocyte depleted blood, leukocyte and platelet depleted blood, a red blood cell suspension, oxygen and carbon dioxide depleted red blood cells, oxygen depleted red blood cells, and plasma.
66. The method of claim 64, wherein said addition gas is selected from the group consisting of oxygen, carbon dioxide, nitric oxide, and combinations thereof.

67. The method of claim 64, wherein said increased level of gas is a physiological level of oxygen bound to hemoglobin.
68. The method of claim 64, further comprising flowing said liquid through a buffer exchange device.
- 5 69. The method of claim 64, wherein said blood product flows through a red blood cell editing device.
70. The method of claim 69, wherein said blood product is selected from the group consisting of a red blood cell suspension and packed red blood cells.
71. A method for extended storage of red blood cells comprising:
- 10 a. obtaining whole blood;
- b. passing said whole blood through a depletion device to prepare a depleted blood product;
- c. storing said depleted blood product in a gas impermeable storage bag for a period of time to prepare a stored depleted blood product; and
- 15 d. passing said stored depleted blood product through a gas addition device to prepare a transfusion blood product.
72. The method of claim 71, wherein said depletion device comprises:
- a. an enclosure;
- b. one or more liquid chambers;
- 20 c. one or more depletion chambers;
- d. at least one gas permeable barrier separating at least one of said one or more liquid chambers from said one or more depletion chambers;
- e. at least one liquid inlet; and
- f. at least one liquid outlet.
- 25 73. The method of claim 72, wherein said one or more liquid chambers further comprise one or more flow control features.

74. The method of claim 72, wherein said one or more liquid chambers are separated from said one or more depletion chambers by more than one gas permeable barriers.
75. The method of claim 74, wherein said at least one gas permeable barrier is a membrane comprising a polyolefin, polytetrafluoroethylene (PTFE), polyvinylidene mono- or di-
5 fluoride (PVDF), a polysulfone, a silicone, an epoxy, a polyester membrane polyethylene, or a ceramic.
76. The method of claim 71, wherein said gas addition device comprises:
- a. an enclosure;
 - b. one or more liquid chambers;
 - 10 c. one or more gas addition chambers;
 - d. at least one gas permeable barrier separating at least one of said one or more liquid chambers from said one or more gas addition chambers;
 - e. at least one liquid inlet; and
 - f. at least one liquid outlet.
- 15 77. The method of claim 76, wherein said one or more liquid chambers further comprise one or more flow control features.
78. The method of claim 76, wherein said gas permeable barrier is a membrane comprising a polyolefin, polytetrafluoroethylene (PTFE), polyvinylidene mono- or di- fluoride (PVDF), a polysulfone, a silicone, an epoxy, a polyester membrane, or a ceramic.
- 20 79. The method of claim 76, wherein said gas permeable barrier is a hydrophobic porous structure.
80. The method of claim 76, wherein said one or more liquid chambers are separated from said one or more gas addition chambers by more than one gas permeable barrier.
81. The method of claim 76, wherein said enclosure is prepared of a material selected from the
25 group consisting of a rigid material, a flexible material, an elastic material, and combinations thereof.

82. The method of claim 76, wherein said liquid chamber is prepared of a material selected from the group consisting of a rigid material, a flexible material, an elastic material, and combinations thereof.
83. The method of claim 71, further comprising one or more steps selected from the group
5 consisting of:
 editing said transfusion blood product;
 irradiating said transfusion blood product;
 performing a buffer exchange of said transfusion blood product; and
 collecting said gas restored blood product in a transfusion bag.
- 10 84. The method of claim 71, wherein said gas impermeable storage bag comprises an outer bag having a barrier film, an inner bag in contact with said depleted blood product.
85. The method of claim 84, wherein said gas impermeable storage bag further comprises a sorbent disposed between said inner bag and said outer bag.
86. A system for extended storage of red blood cells, the system comprising:
15 a phlebotomy needle;
a blood collection bag;
an additive solution;
a depletion device;
a device for leukocyte reduction;
20 a device for editing red blood cells;
a device for inactivating pathogens;
a device for reducing the volume of a blood product;
a device for exchanging the buffer of a blood product;
a gas impermeable storage bag for storing a blood product;
25 a device for adding a gas to the stored blood product prior to transfusion; and
tubing connecting said devices, said collection bag, and said storage bag.
87. The system according claim 86, wherein said depletion device comprises:
 a. an enclosure;

- b. one or more liquid chambers;
 - c. one or more depletion chambers;
 - d. at least one gas permeable barrier separating at least one of said one or more liquid chambers from said one or more depletion chambers;
 - 5 e. at least one liquid inlet; and
 - f. at least one liquid outlet.
88. The system according claim 87, wherein said one or more liquid chambers further comprise one or more flow control features.
89. The depletion device of claim 87, wherein said one or more liquid chambers are separated
10 from said one or more depletion chambers by more than one gas permeable barriers.
90. The depletion device of claim 89, wherein said at least one gas permeable barrier is a membrane comprising a polyolefin, polytetrafluoroethylene (PTFE), polyvinylidene mono- or di- fluoride (PVDF), a polysulfone, a silicone, an epoxy, a polyester, a polyethylene, or a ceramic.
- 15 91. A depletion device comprising:
an enclosure;
a liquid inlet;
a liquid outlet; and
one or more depletion units comprising:
20 at least two connectors for liquid communication with other depletion units, said liquid inlet, or said liquid outlet;
a gas permeable membrane exposable to oxygen or oxygen and carbon dioxide depleted gas; and
one or more channels in liquid communication with said liquid inlet and said liquid
25 outlet,
wherein said one or more channels having at least one exposed longitudinal side
in contact with said gas permeable membrane are adapted to receiving and conveying a blood product.
92. The depletion device of claim 91, wherein said one or more channels are micro channels.

93. The depletion device of claim 91, wherein said one or more channels have a cross-sectional shape selected from the group consisting of rectangular, circular, and irregular shape.
94. The depletion device of claim 93, wherein said one or more channels have a changing cross-sectional area along its longitudinal path.
- 5 95. The depletion device of claim 91, wherein said one or more channels have more than one cross-sectional shapes along its longitudinal path selected from one or more of the group consisting of rectangular, circular, and irregular shape.
96. The depletion device of claim 93, wherein said one or more channels having said irregular shape cross-sections are defined by the space between a side of said enclosure and the rough
10 surface of said gas permeable membrane.
97. The depletion device of claim 91, wherein said one or more channels each has length that is at least ten fold of the length of said enclosure while being fully contained within said enclosure.
98. The depletion device of claim 91, wherein said one or more channels are configured to
15 generate mixing in said blood product.
99. The depletion device of claim 98, wherein said one or more channels have longitudinal paths selected from the group of meandering, sinuous, undulating, sinusoidal, spiral, partially spiral, and zig-zag to generate said mixing.
100. The depletion device of claim 91, wherein said enclosure further comprises a gas
20 chamber in contact with said gas permeable membrane.
101. The depletion device of claim 100, wherein said gas chamber further comprises a gas inlet and a gas outlet adapted to receiving and expelling a flushing gas.
102. The depletion device of claim 100, wherein said gas chamber is adapted to receiving and holding a volume of gas.

103. The depletion device of claim 100, wherein said enclosure further comprising a second gas permeable membrane and a second gas chamber.
104. The depletion device of claim 103, wherein said one or more channels have a second exposed longitudinal side in contact with a gas permeable membrane.
- 5 105. The depletion device of claim 103, wherein said first and second gas chambers are connected to a gas inlet and a gas outlet adapted to receiving and expelling a flushing gas.
106. The depletion device of claim 103, wherein said first and second gas chambers are adapted to receiving and holding a volume of gas.
107. The depletion device of claim 103, wherein said first and second gas chambers are
10 plenum chambers.
108. The depletion device of claim 91, further comprising one or more liquid flow control devices.
109. The depletion device of claim 91, further comprising one or more gas sensors.
110. The depletion device of claim 91, wherein said one or more depletion units is selected
15 from the group consisting of one depletion unit, two depletion units, three depletion units, four depletion units, and five depletion units, or more.
111. The depletion device of claim 110, wherein said one or more depletion units are connected in parallel to conduct parallel flow of said red blood cells from said fluid inlet to said fluid outlet.
- 20 112. The depletion device of claim 110, wherein said one or more depletion units are connected in series to conduct continuous flow of said red blood cells from said fluid inlet to said fluid outlet.
113. The depletion device of claim 91, wherein said one or more channels is selected from the group consisting of one channel, two channels, three channels, four channels, five channels,
25 six channels, seven channels, eight channels, nine channels, and ten channels, or more.

114. The depletion device of claim 91, wherein said one or more depletion units further comprise a gas depleting media.
115. The depletion device of claim 114, wherein said gas depleting media is a gas sorbent.
116. The depletion device of claim 114, wherein said gas depleting media is selected from the
5 group consisting of a gel, a solid, a gas, and combinations thereof.
117. The depletion device of claim 114, wherein said depletion media is held in one or more packets.
118. The depletion device of claim 91, further comprising a leukocyte reduction device.
119. The depletion device of claim 91, further comprising a platelet separation device.
- 10 120. The depletion device of claim 91, further comprising a red blood cell editing device.

1/18

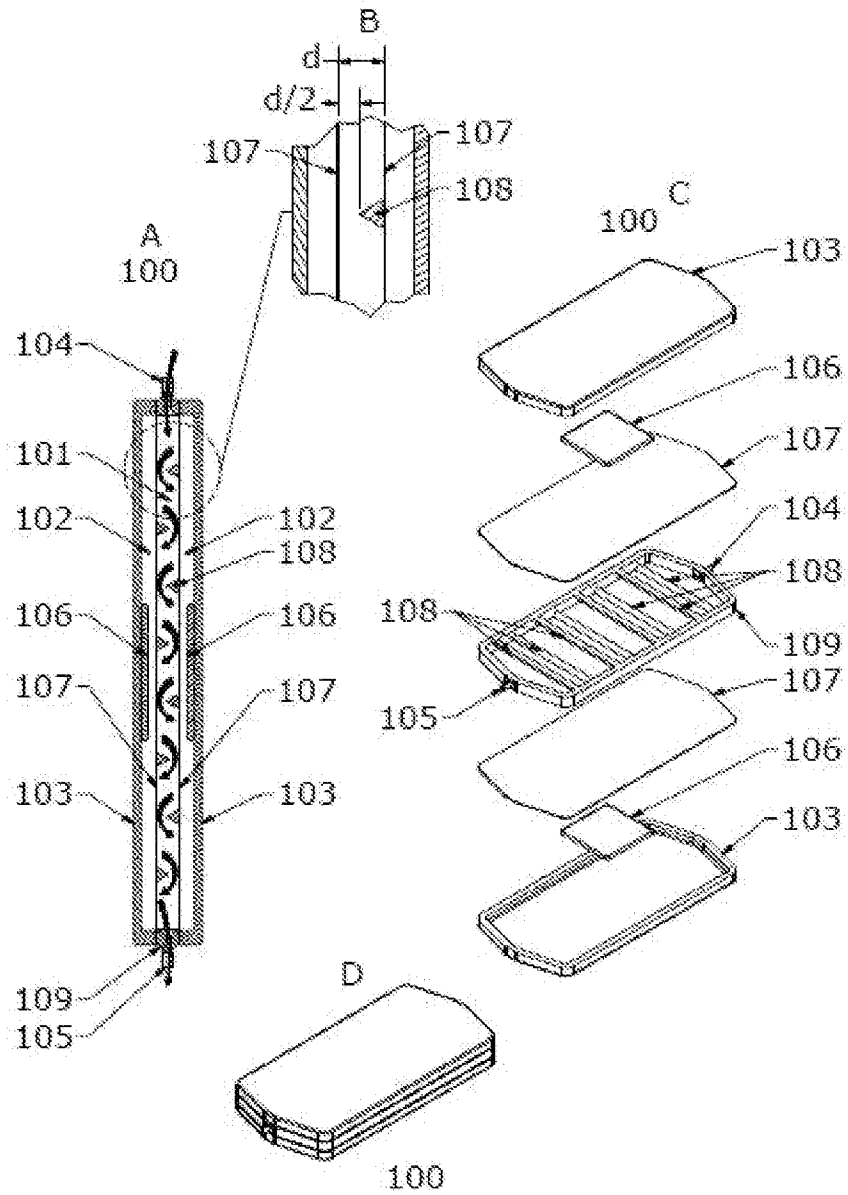

FIG. 1

2/18

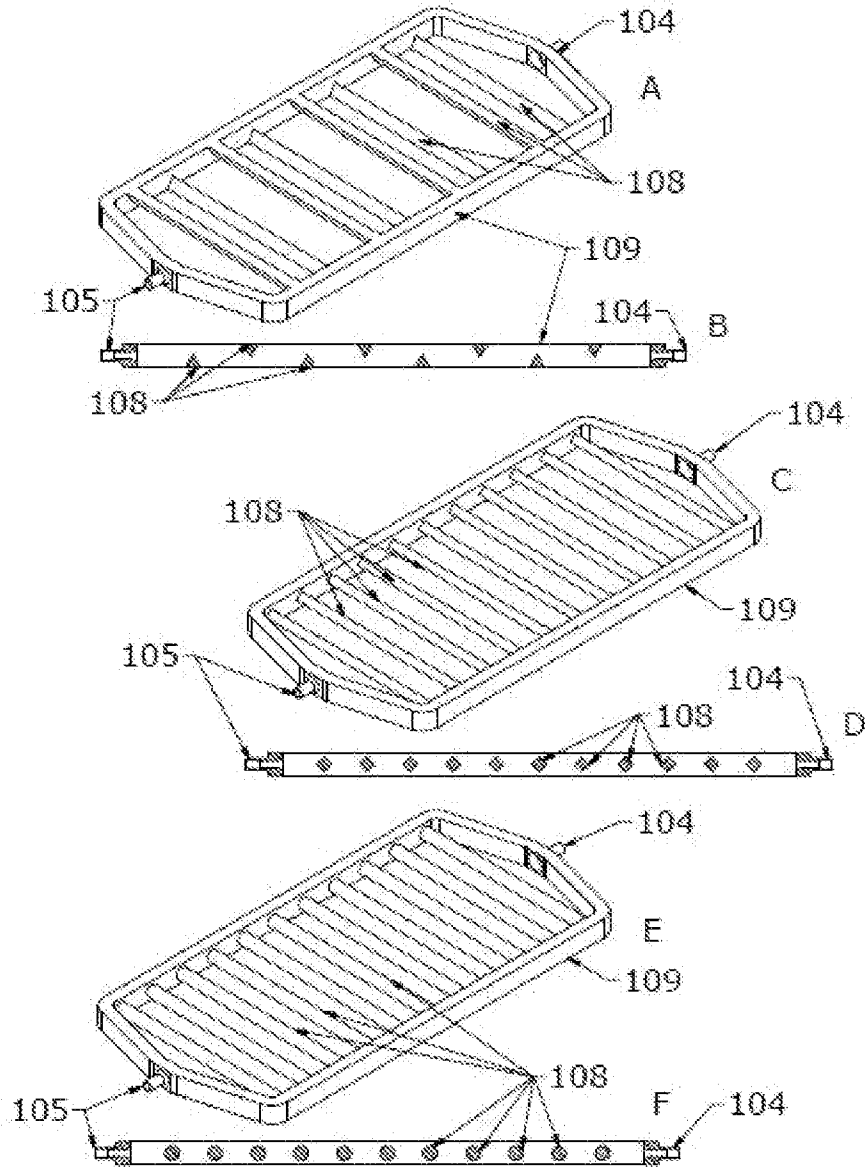

FIG. 2

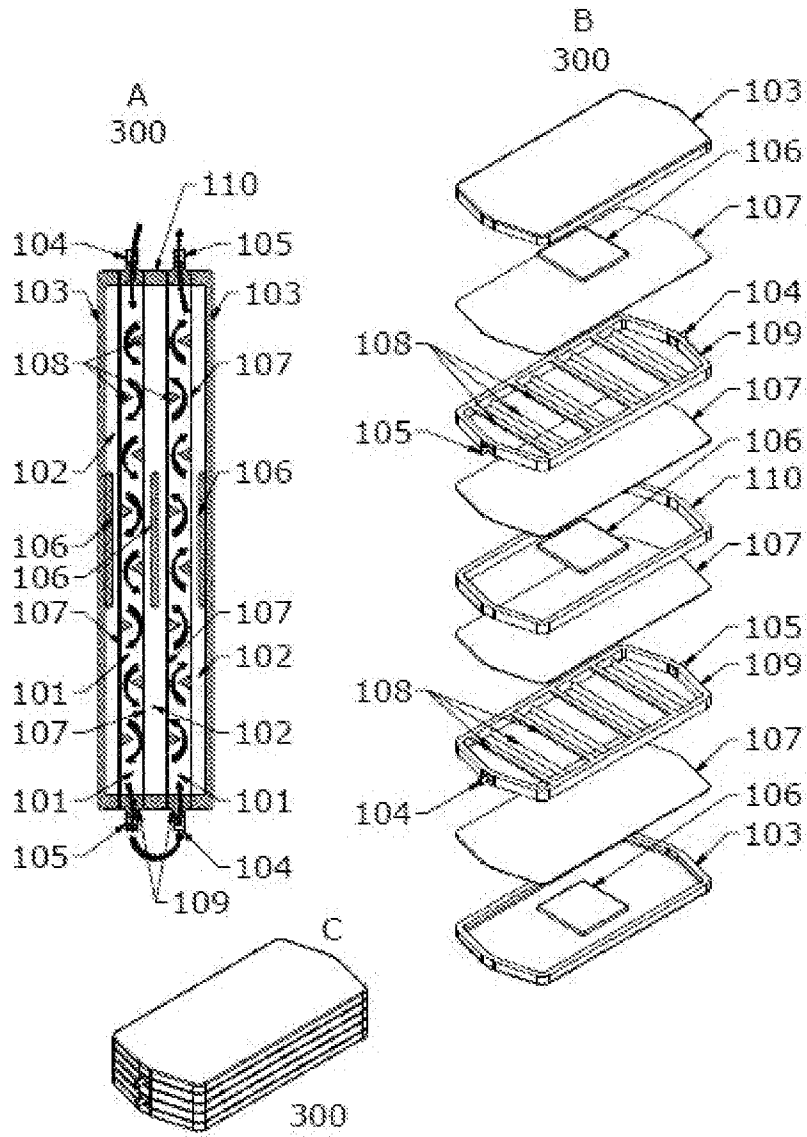

FIG. 3

4/18

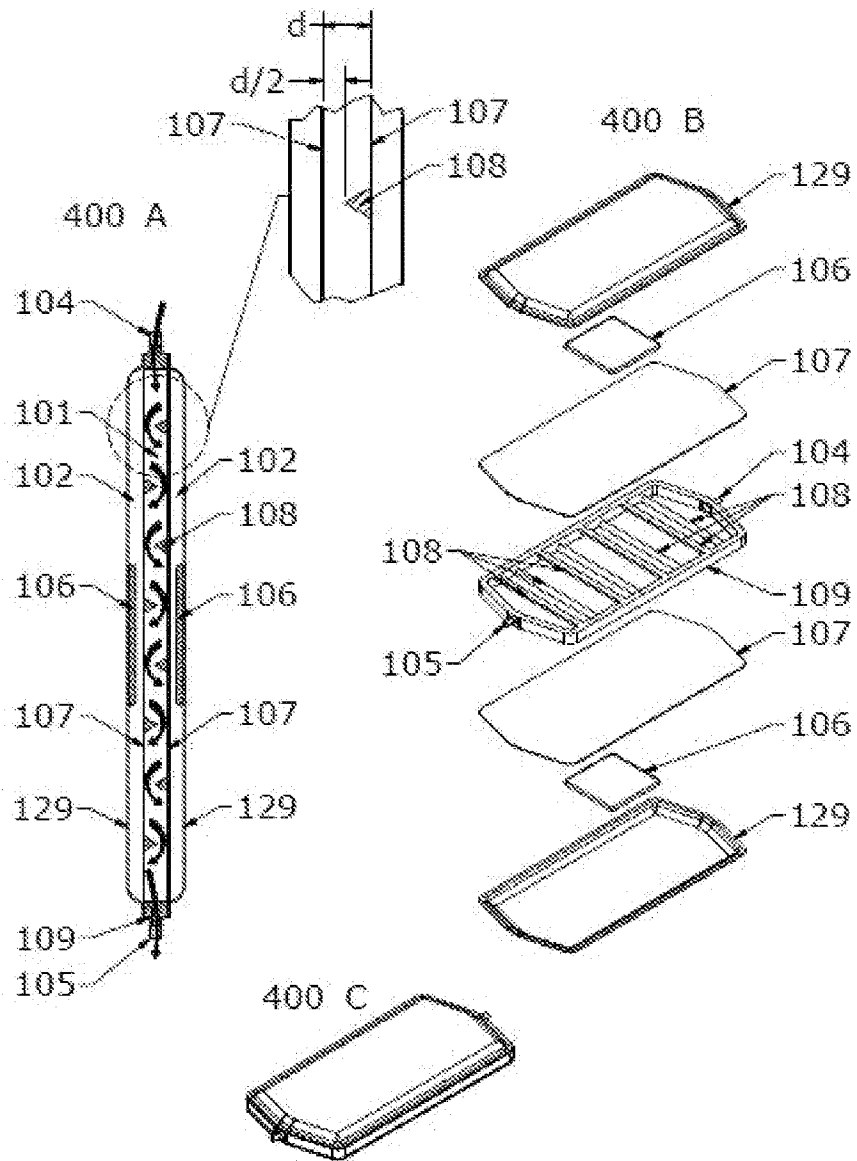

FIG. 4

6/18

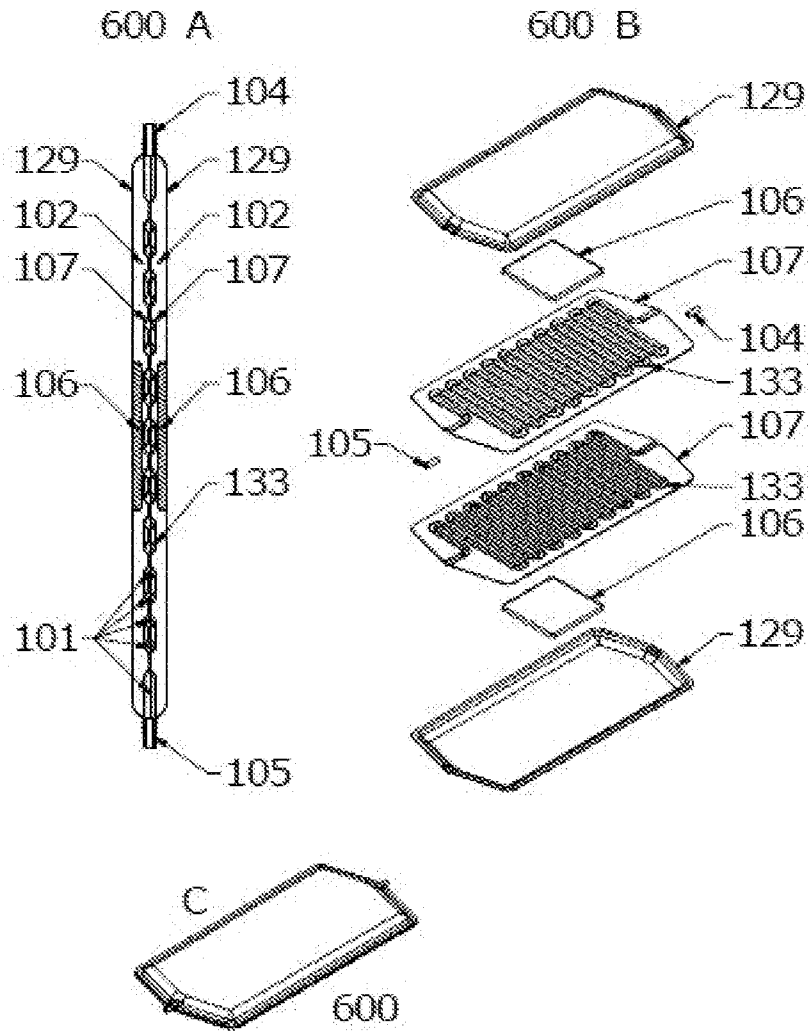

FIG. 6

7/18

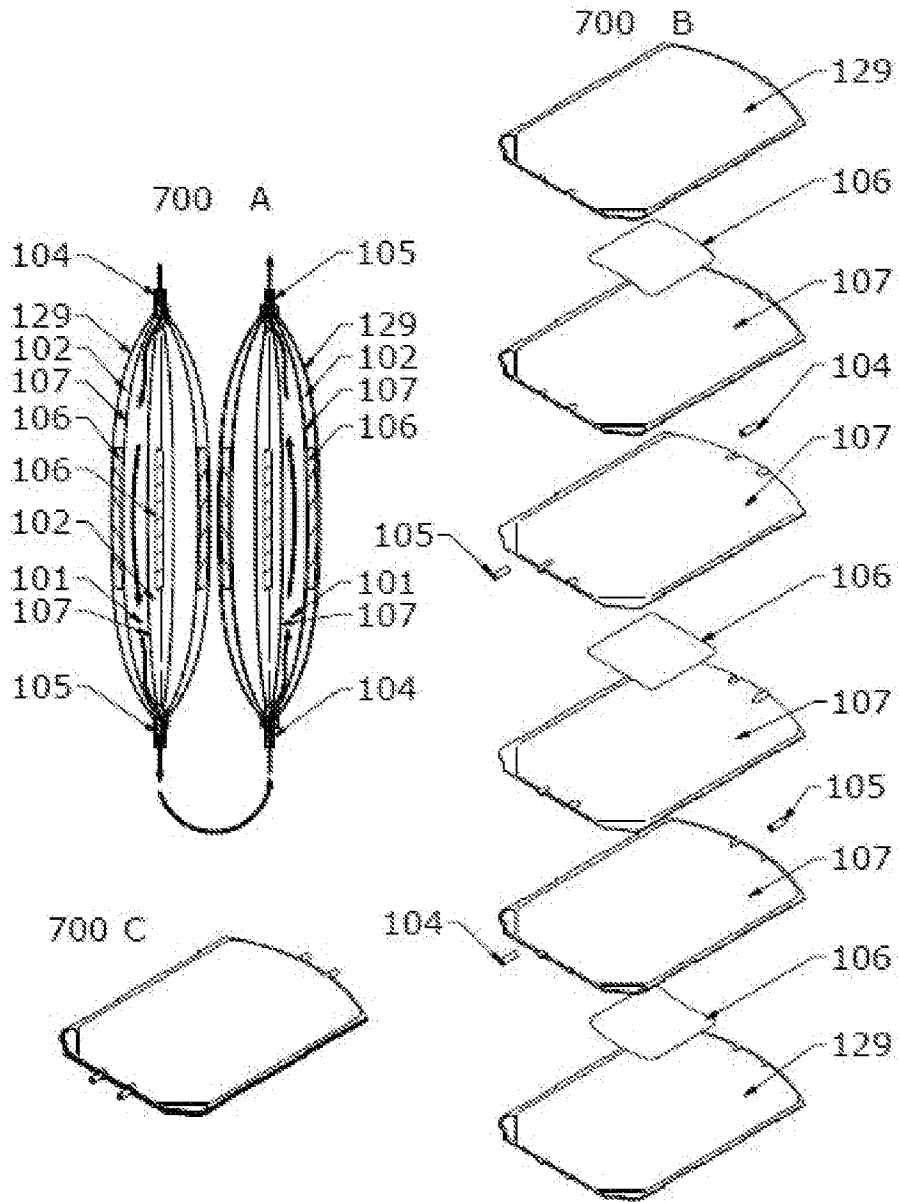

FIG. 7

8/18

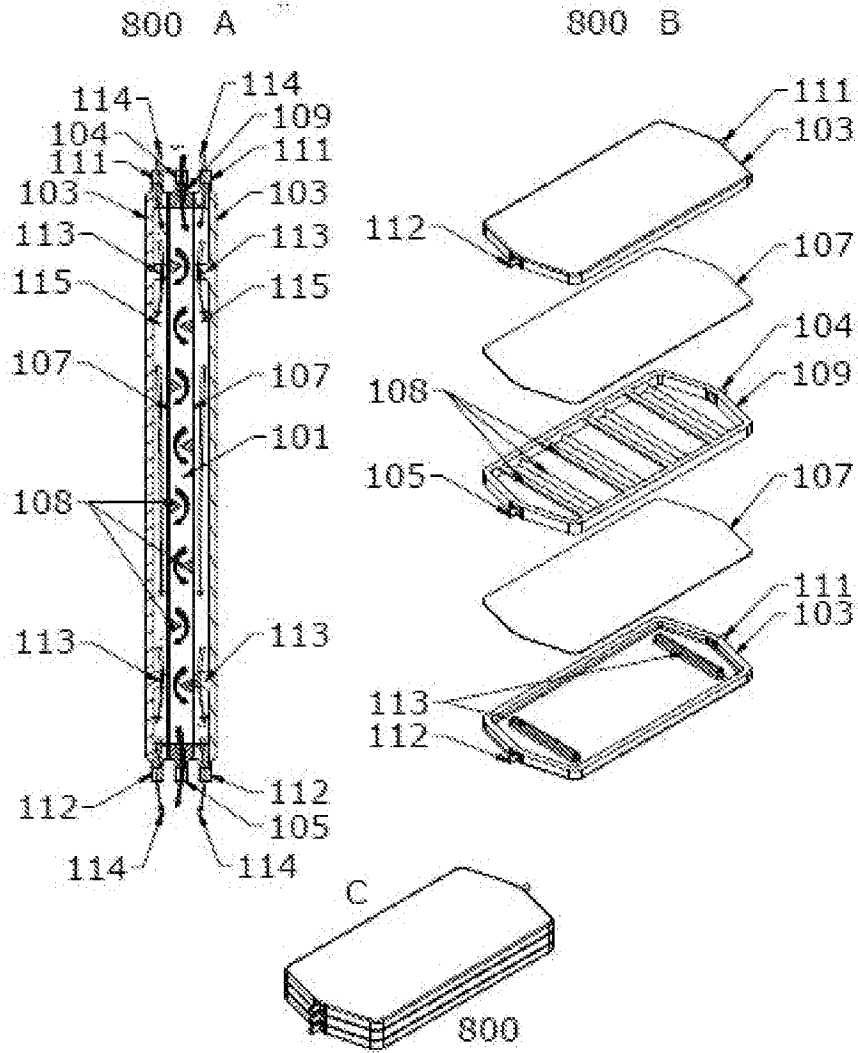

FIG. 8

9/18

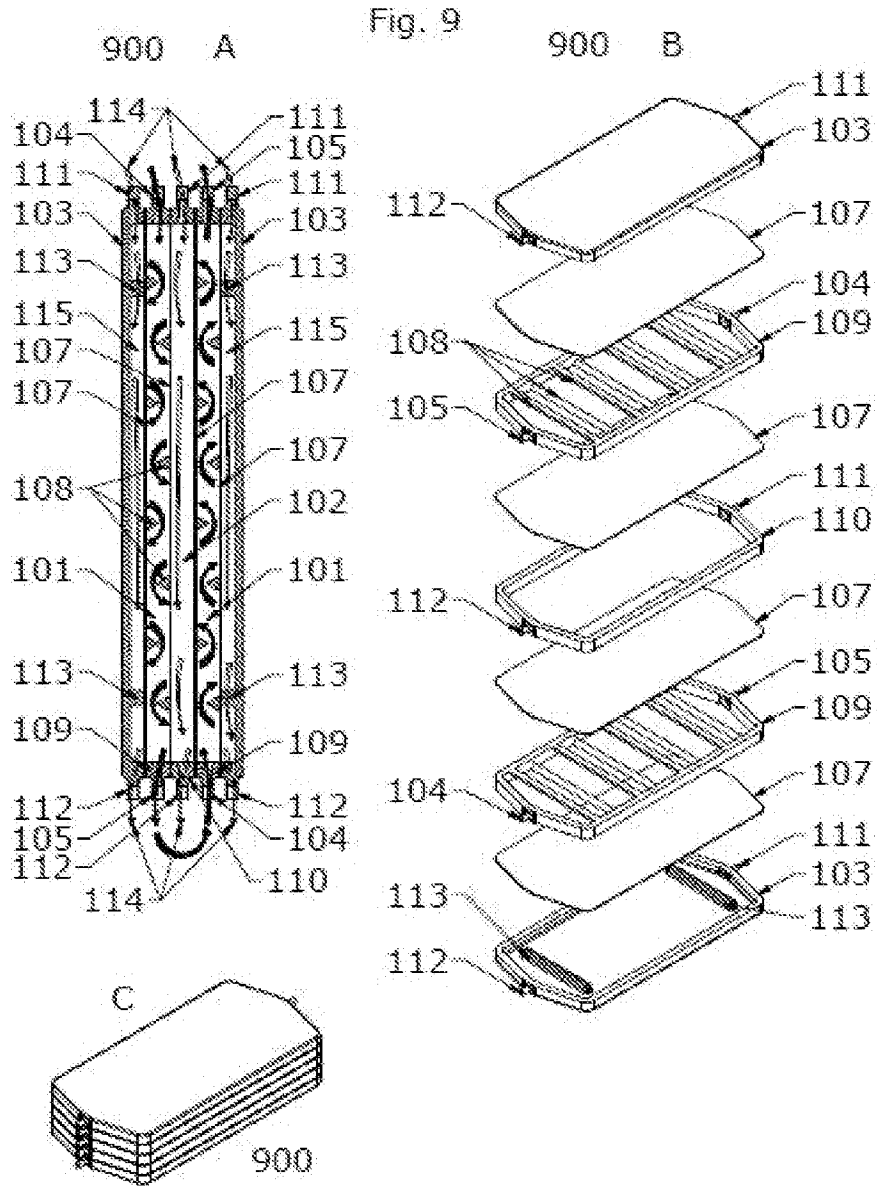

FIG. 9

10/18

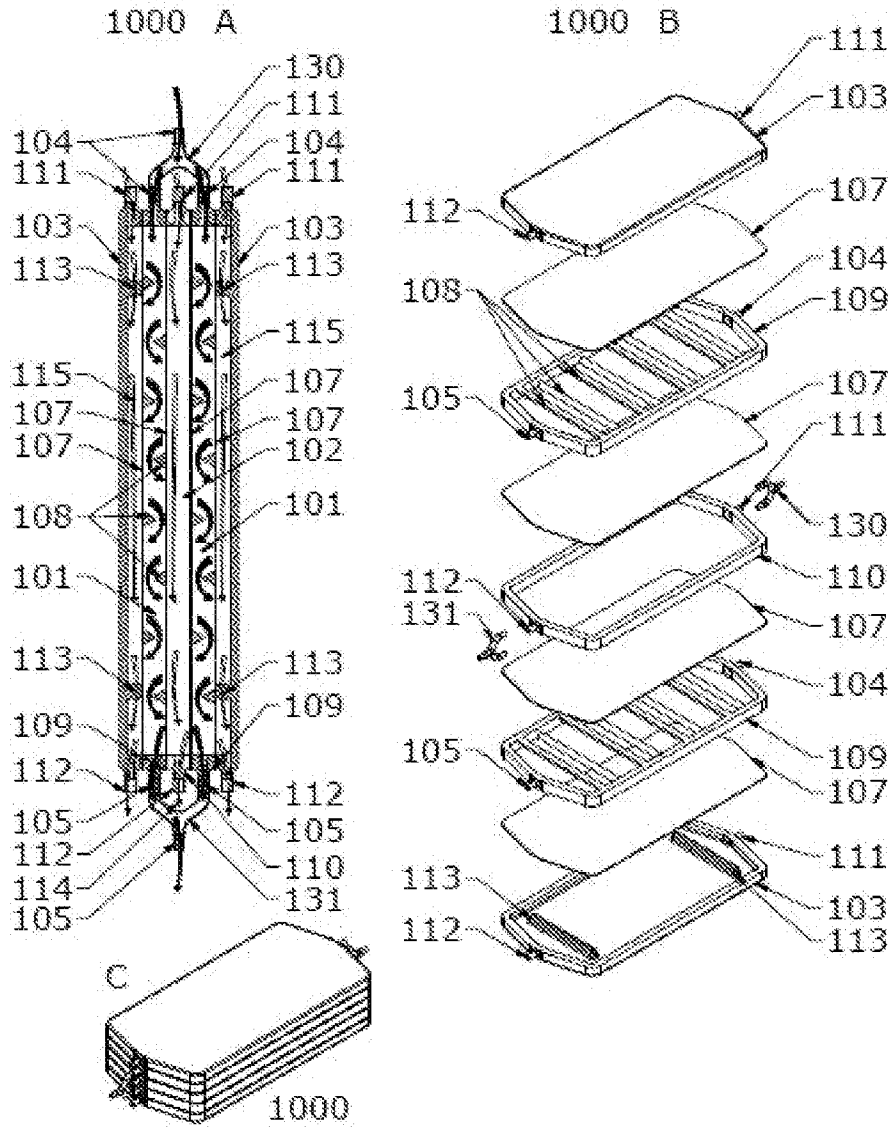

FIG. 10

11/18

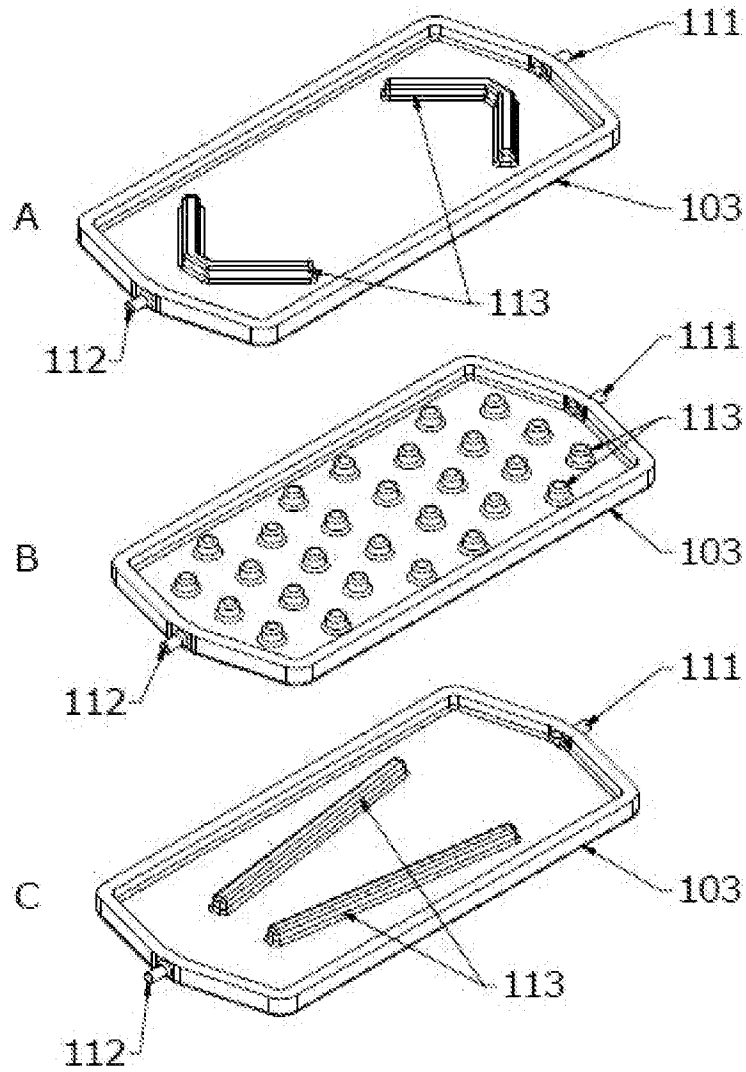

FIG. 11

12/18

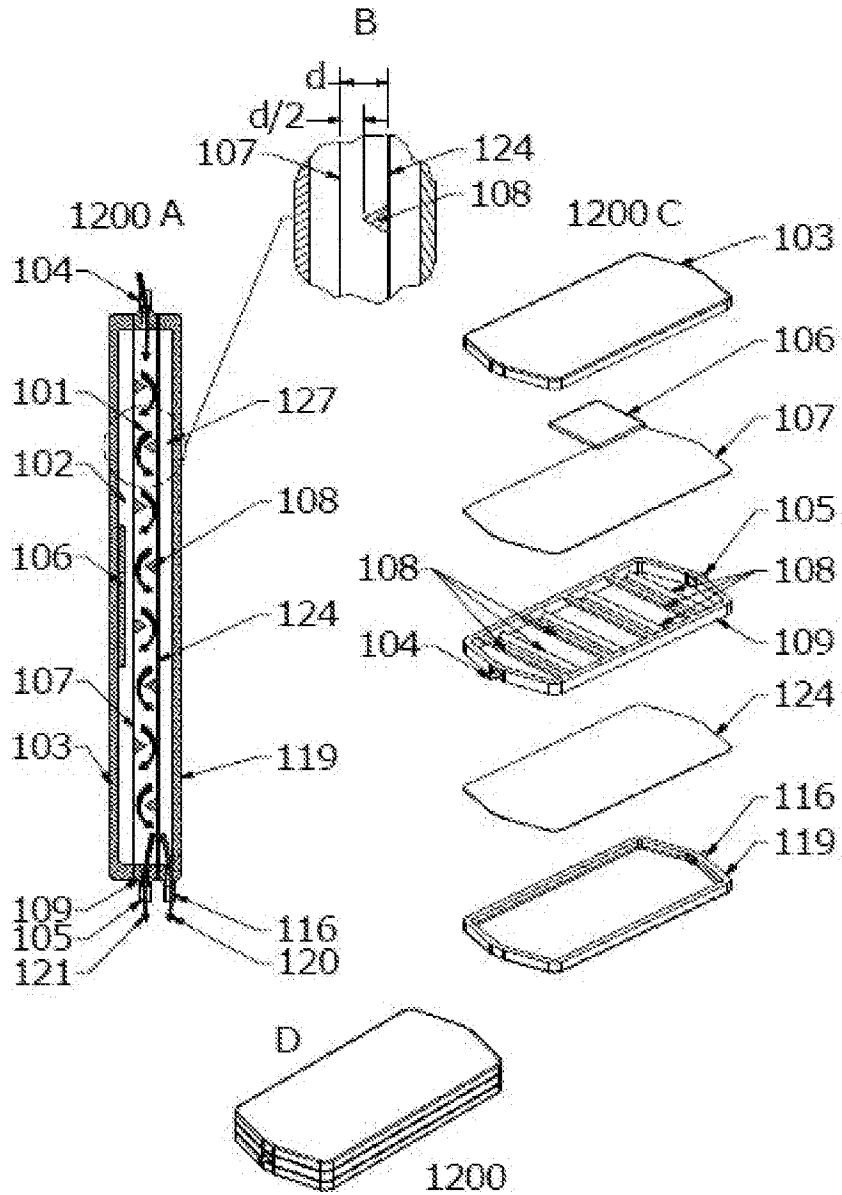

FIG. 12

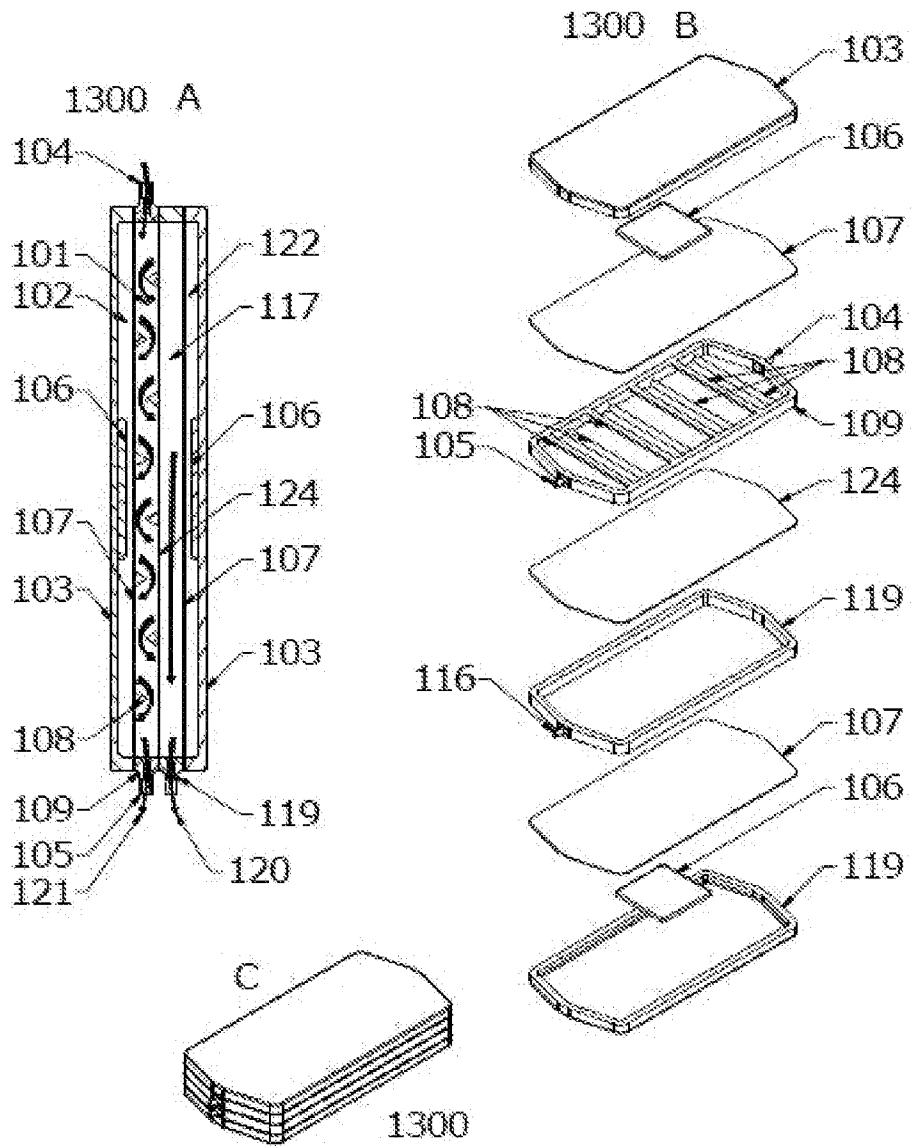

FIG. 13

14/18

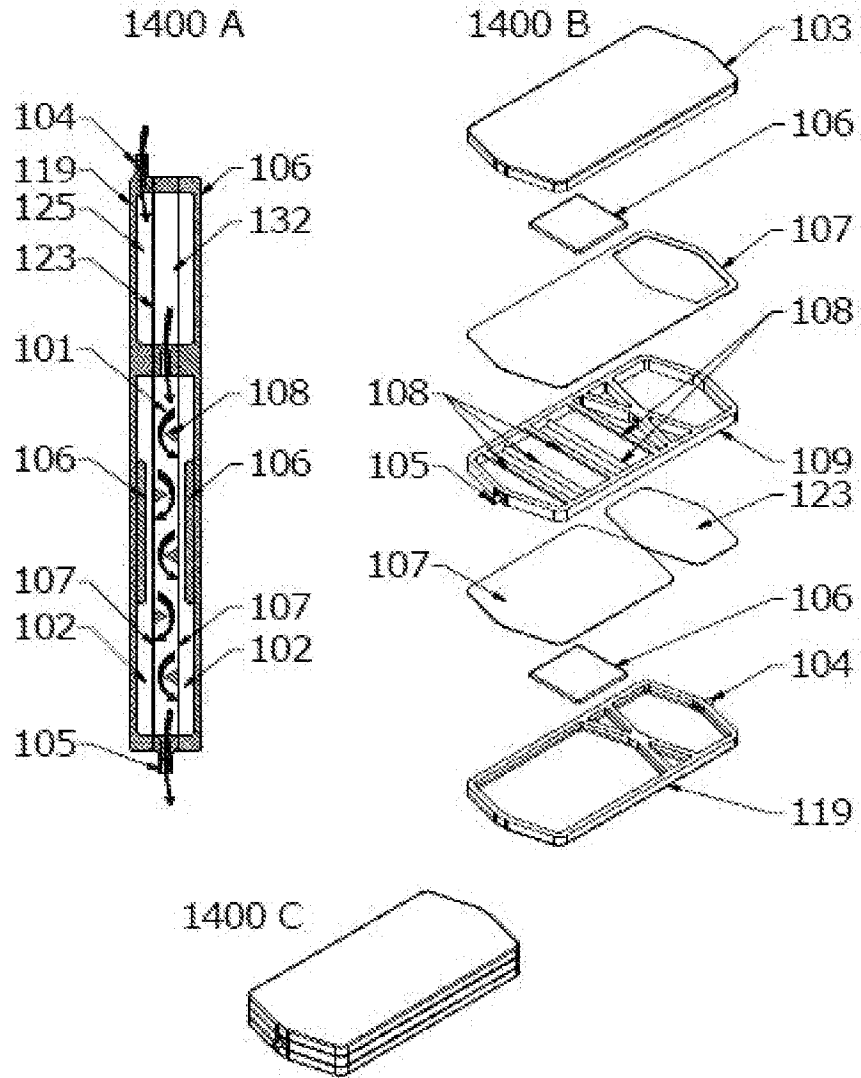

FIG. 14

15/18

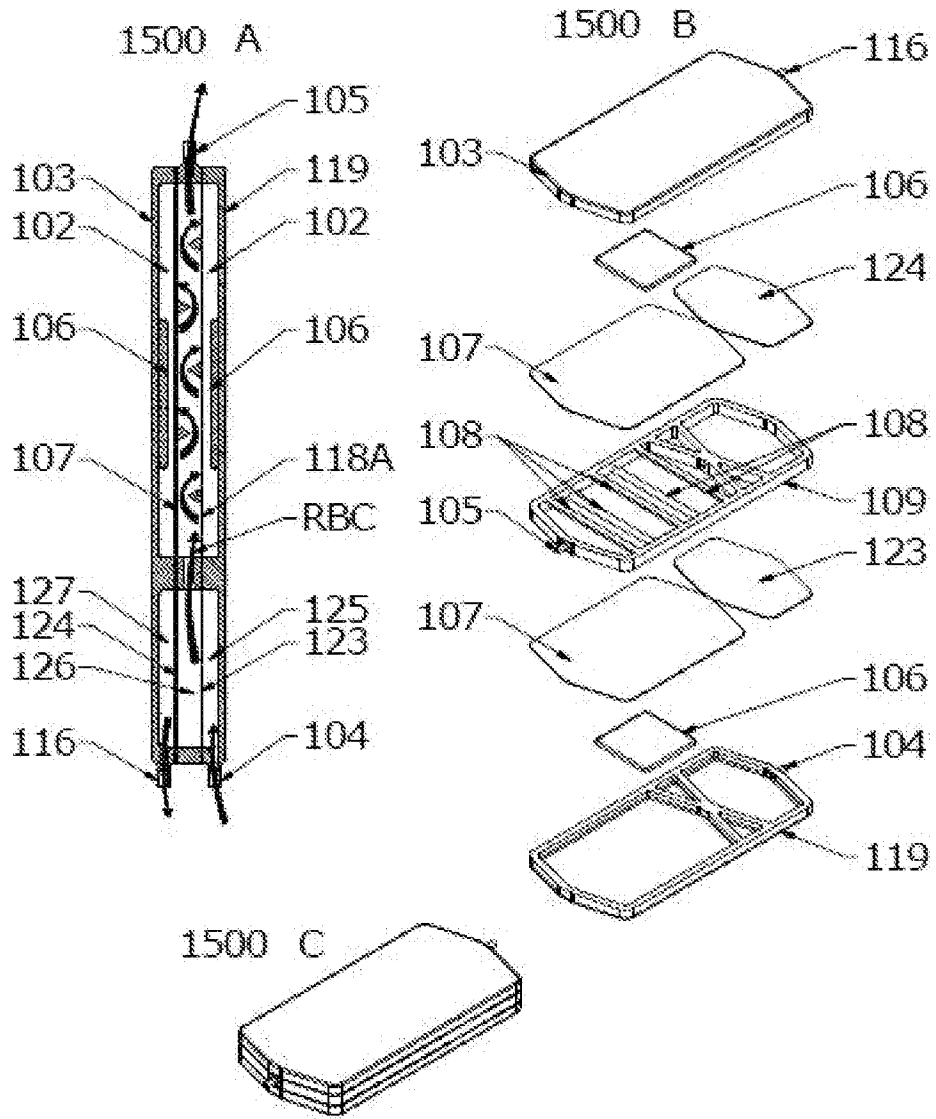

FIG. 15

16/18

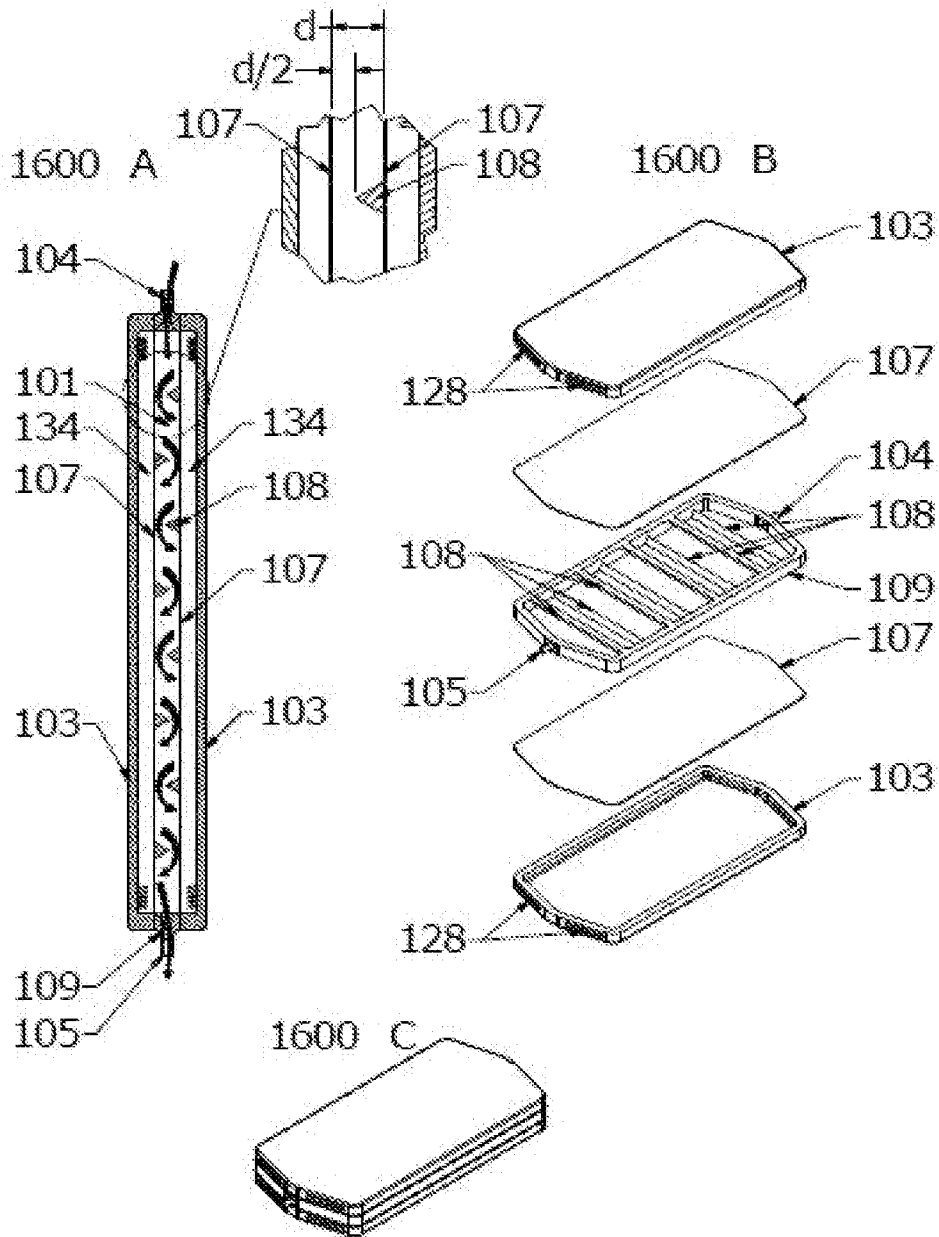

FIG. 16

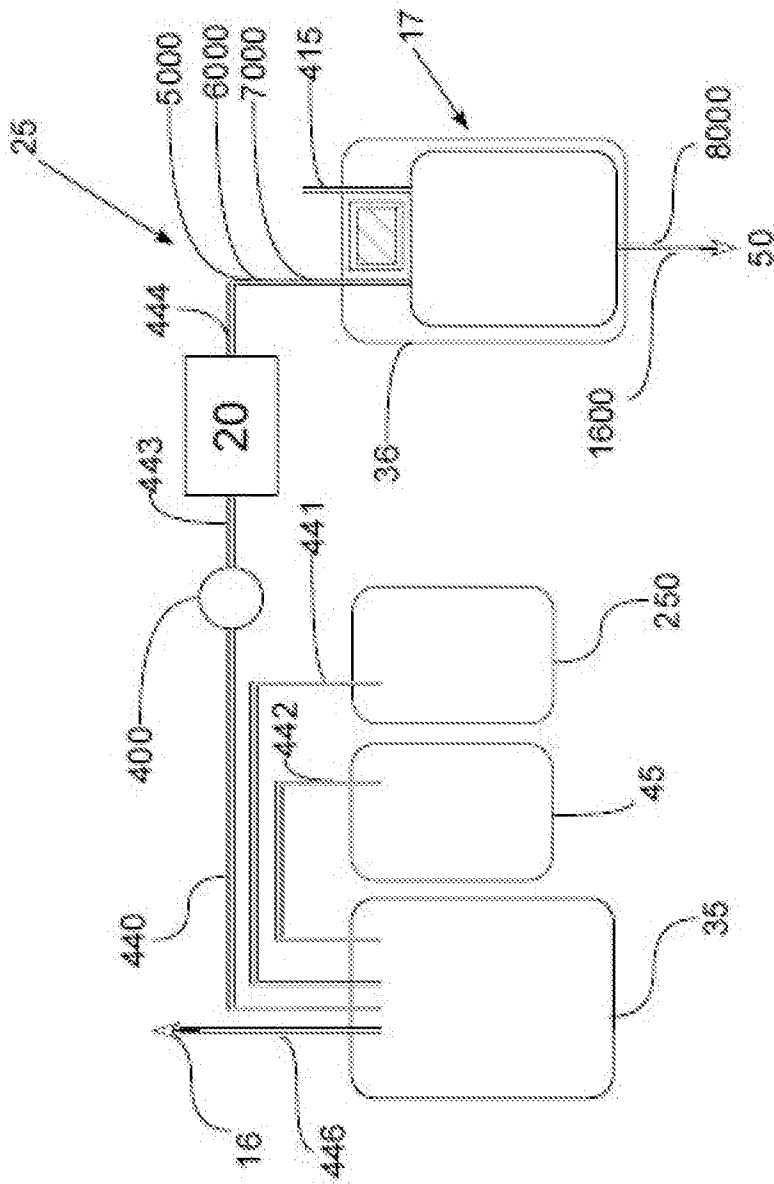

FIG.18

INTERNATIONAL SEARCH REPORT

International application No.
PCT/US2014/019537

Box No. II Observations where certain claims were found unsearchable (Continuation of item 2 of first sheet)

This international search report has not been established in respect of certain claims under Article 17(2)(a) for the following reasons:

1. Claims Nos.: 71-85
because they relate to subject matter not required to be searched by this Authority, namely:
see FURTHER INFORMATION sheet PCT/ISA/210
2. Claims Nos.:
because they relate to parts of the international application that do not comply with the prescribed requirements to such an extent that no meaningful international search can be carried out, specifically:
3. Claims Nos.:
because they are dependent claims and are not drafted in accordance with the second and third sentences of Rule 6.4(a).

Box No. III Observations where unity of invention is lacking (Continuation of item 3 of first sheet)

This International Searching Authority found multiple inventions in this international application, as follows:

see additional sheet

1. As all required additional search fees were timely paid by the applicant, this international search report covers all searchable claims.
2. As all searchable claims could be searched without effort justifying an additional fees, this Authority did not invite payment of additional fees.
3. As only some of the required additional search fees were timely paid by the applicant, this international search report covers only those claims for which fees were paid, specifically claims Nos.:
4. No required additional search fees were timely paid by the applicant. Consequently, this international search report is restricted to the invention first mentioned in the claims; it is covered by claims Nos.:
1-34, 56-63

Remark on Protest

- The additional search fees were accompanied by the applicant's protest and, where applicable, the payment of a protest fee.
- The additional search fees were accompanied by the applicant's protest but the applicable protest fee was not paid within the time limit specified in the invitation.
- No protest accompanied the payment of additional search fees.

INTERNATIONAL SEARCH REPORT

International application No
PCT/US2014/019537

A. CLASSIFICATION OF SUBJECT MATTER
INV. A01N1/02
ADD.
According to International Patent Classification (IPC) or to both national classification and IPC

B. FIELDS SEARCHED
Minimum documentation searched (classification system followed by classification symbols)
A01N A61J A61L

Documentation searched other than minimum documentation to the extent that such documents are included in the fields searched

Electronic data base consulted during the international search (name of data base and, where practicable, search terms used)
EPO-Internal, WPI Data

C. DOCUMENTS CONSIDERED TO BE RELEVANT

Category*	Citation of document, with indication, where appropriate, of the relevant passages	Relevant to claim No.
X	US 6 162 396 A (BITENSKY MARK W [US] ET AL) 19 December 2000 (2000-12-19) cited in the application the whole document	1,2,4,7, 9,10,19, 20,22, 24-29, 33,34, 56-58, 62,63
X	WO 2011/014855 A2 (UNIV PITTSBURGH [US]; NEW HEALTH SCIENCES INC [US]; FEDERSPIEL WILLIAM) 3 February 2011 (2011-02-03) the whole document	1,2, 4-22, 24-29, 33,34, 56-58, 62,63
	----- -/--	

Further documents are listed in the continuation of Box C.

See patent family annex.

* Special categories of cited documents :

- "A" document defining the general state of the art which is not considered to be of particular relevance
- "E" earlier application or patent but published on or after the international filing date
- "L" document which may throw doubts on priority claim(s) or which is cited to establish the publication date of another citation or other special reason (as specified)
- "O" document referring to an oral disclosure, use, exhibition or other means
- "P" document published prior to the international filing date but later than the priority date claimed

- "T" later document published after the international filing date or priority date and not in conflict with the application but cited to understand the principle or theory underlying the invention
- "X" document of particular relevance; the claimed invention cannot be considered novel or cannot be considered to involve an inventive step when the document is taken alone
- "Y" document of particular relevance; the claimed invention cannot be considered to involve an inventive step when the document is combined with one or more other such documents, such combination being obvious to a person skilled in the art
- "&" document member of the same patent family

Date of the actual completion of the international search 2 May 2014	Date of mailing of the international search report 10/07/2014
Name and mailing address of the ISA/ European Patent Office, P.B. 5818 Patentlaan 2 NL - 2280 HV Rijswijk Tel. (+31-70) 340-2040, Fax: (+31-70) 340-3016	Authorized officer Küster, Gunilla

INTERNATIONAL SEARCH REPORT

International application No
PCT/US2014/019537

C(Continuation). DOCUMENTS CONSIDERED TO BE RELEVANT		
Category*	Citation of document, with indication, where appropriate, of the relevant passages	Relevant to claim No.
X	WO 2011/046841 A1 (NEW HEALTH SCIENCES INC [US]; YOSHIDA TATSURO [US]; VERNUCCI PAUL J [U] 21 April 2011 (2011-04-21) the whole document	1-34, 56-63
A	----- TATSURO YOSHIDA ET AL: "Anaerobic storage of red blood cells", BLOOD TRANSFUSION, vol. 8, 1 January 2010 (2010-01-01), pages 220-36, XP055090172, DOI: 10.2450/2010.0022-10 page 230 - page 231 -----	1,56

INTERNATIONAL SEARCH REPORT

Information on patent family members

International application No PCT/US2014/019537

Patent document cited in search report	Publication date	Patent family member(s)	Publication date
US 6162396	A	19-12-2000	NONE
WO 2011014855	A2	03-02-2011	AU 2010278768 A1 15-03-2012
			CA 2772320 A1 03-02-2011
			EP 2459247 A2 06-06-2012
			JP 2013500794 A 10-01-2013
			NZ 598410 A 30-04-2014
			US 2012129149 A1 24-05-2012
			WO 2011014855 A2 03-02-2011
WO 2011046841	A1	21-04-2011	AU 2010307084 A1 31-05-2012
			CA 2781866 A1 21-04-2011
			CN 102711865 A 03-10-2012
			EP 2355860 A1 17-08-2011
			JP 2013507226 A 04-03-2013
			US 2012024156 A1 02-02-2012
			US 2013333561 A1 19-12-2013
			WO 2011046841 A1 21-04-2011

FURTHER INFORMATION CONTINUED FROM PCT/ISA/ 210

This International Searching Authority found multiple (groups of) inventions in this international application, as follows:

1. claims: 1-34, 56-63

Device and method for depleting a gas from a liquid, in particular comprising means for oxygen depletion by means of a depletion gas or comprising a depletion material

2. claims: 35-55, 64-70

Device and method for adding a gas to a liquid, in particular details regarding the gas addition chamber and the addition gas

3. claims: 86-90

System for extended storage of red blood cells, comprising a phlebotomy needle, a collection bag, a storage bag and a plurality of devices for treating a blood product in addition to a depletion device (not necessarily comprising the features of claim 1) and a device for adding gas (not necessarily comprising the features of claim 35)

4. claims: 91-120

A depletion device comprising one or more depletion units comprising at least two connectors and one or more channels having at least one exposed longitudinal side in contact with a gas permeable membrane

FURTHER INFORMATION CONTINUED FROM PCT/ISA/ 210

Continuation of Box II.1

Claims Nos.: 71-85

Rule 39.1(iv) PCT - Method for treatment of the human or animal body by surgery: It is evident from the description that the step a. of "obtaining whole blood" in claim 71 is a surgical step (see [0039], and further in [0176]: "Components conventionally associated with the process of blood collection are a phlebotomy needle 16, a blood collection bag [...]"), thus rendering the method as a whole surgical.